



More Precision

colorSENSOR // Colour Sensors, LED Analyzers





Micro-Epsilon Eltrotec has 40 year's experience in the development and use of colour recognition sensors and fibre optic technology.

In production and quality assurance, a number of very different types of colour sensor are responsible for high productivity and cost reduction.

The sensors record colour values, intensities and functions, and do so on various surfaces and selfluminous objects.

The very latest colour sensors and high quality fibre optics are combined in a comprehensive product range.

They are used where high efficiency and effectiveness are called for.

Numerous renowned customers worldwide rely on accurate colour recognition sensors from Micro-Epsilon Eltrotec and their production.

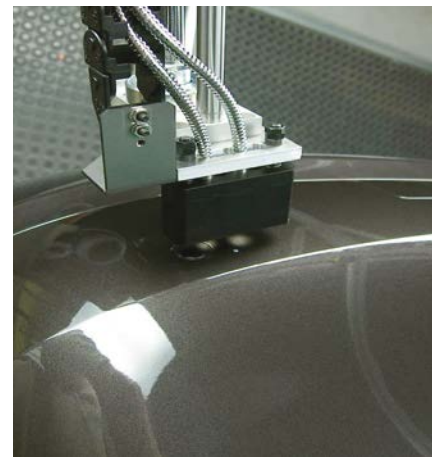

Basics and selection criteria

Page

4 - 5

Universal colour sensors

Model	Button teach	Software teach	Colour difference	Page
colorSENSOR LT-1-LC-10	3	-	$\Delta E \geq 1.5$	6 - 7
colorSENSOR LT-1-LC-20	-	31 colours	$\Delta E \geq 1.5$	8 - 9
colorSENSOR LT-1-ST	3	15 colours	$\Delta E \geq 1.5$	10 - 11
colorSENSOR WLCS-M-41	4	-	$\Delta E \geq 1.5$	12 - 13
colorSENSOR LT-2-ST	-	255 colours	$\Delta E \geq 0.8$	14 - 15
colorSENSOR LT-2-DU	8	255 colours	$\Delta E \geq 0.8$	16 - 17
colorSENSOR LT-3-HE	31	31 colours	$\Delta E \geq 0.5$	18 - 19
colorSENSOR LT-3-LU	31	31 colours	$\Delta E \geq 0.5$	20 - 21

Colour sensors for special measurement targets

Model	Description	Colour difference	Page
colorSENSOR OT-3-MA	colour control from a great distance for matt surfaces	$\Delta E \geq 0.5$	22 - 23
colorSENSOR OT-3-GL	colour control on non-homogeneous and shiny surfaces	$\Delta E \geq 0.5$	24 - 25
colorSENSOR OT-3-HR	colour control on reflective and textured surfaces	$\Delta E \geq 0.5$	26 - 27
colorSENSOR OT-3-LD	colour control at a very large distance	$\Delta E \geq 1.5$	28 - 29
colorSENSOR OT-3-LU	colour control of fluorescent objects	$\Delta E \geq 0.5$	30 - 31

Quality inspection of LEDs and illumination

Model	Description	Measuring points	Page
colorSENSOR LT-2-ST	LED tests of function, colour and intensity	1	14 - 15
colorSENSOR LT-2-DU	LED tests of function, colour and intensity	2	16 - 17
colorSENSOR LT-3-HE	LED tests of function, colour and intensity with high accuracy	1	18 - 19
colorSENSOR OT-3-MA	LED lamp and illumination test of function, colour and intensity	1	22 - 23
colorSENSOR OT-3-LD	LED lamp and illumination test of function, colour and intensity from a great distance	1	28 - 29
colorCONTROL MFA	LED tests of function, colour and intensity	1/5/10/15/20	32 - 33

Accessories

	Page
Fibre optics	34 - 41
Cable	42
Pin assignment of cables (power supply)	43

Standard colour space CIE 1931 (xy colour space)

This colour space corresponds to the human colour perception (very large green and small blues/red sector).

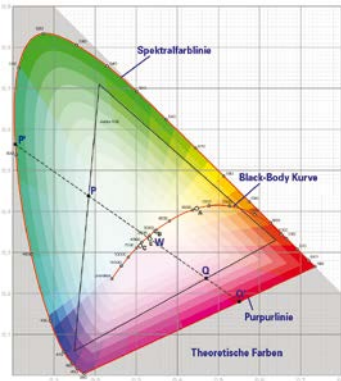

CIE – Commission internationale de l'éclairage
 CIE standardised theoretical primary colours
 x = red; y = green; z = blue (x+y+z = 1)
 Colour spectrum = „pure“ colours
 W = whitepoint (x=y=z=1/3)
 Black body curve = colour as the temperature of an ideal black radiator
 Suitable for green and active light (LED) test

Standard colour space CIE Lab

Ideal colour space for colour test, as each colour range is the same size.

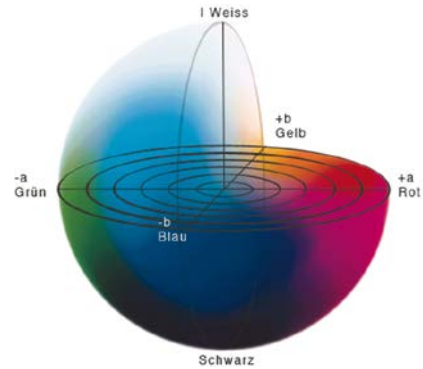

Each colour is defined by the colour location (L*; a*;b*)
 L* = Luminosity value (black = 0; white = 100)
 a* = Green / red value (green = -100; red = +100)
 b* = Blue / yellow value (blue = -100; yellow = +100)

HSV / HSI colour space

Ideal colour space for LED inspection.
 Is used primarily with the colorCONTROL MFA series.

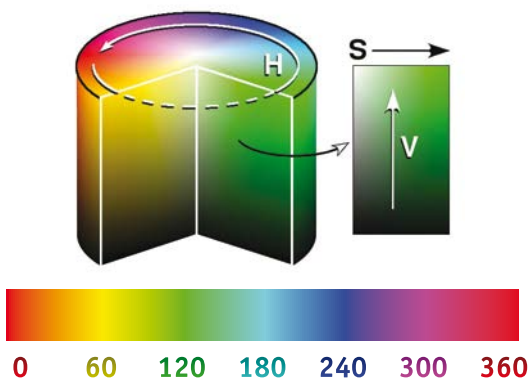

Each colour is defined by the colour location (H; S; V)
 H= Hue (red = 0°; green = 120°; blue = 240°)
 S= Saturation
 (neutral grey = 0%; „pure“ colour = 100 %)
 V= Value of luminosity
 I = Intensity (light intensity)
 (dark = 0%; totally light = 100%)

What is meant by Delta E?

Delta E; ΔE; dE = a measure of the perceived colour difference between two colours (DIN 5033)

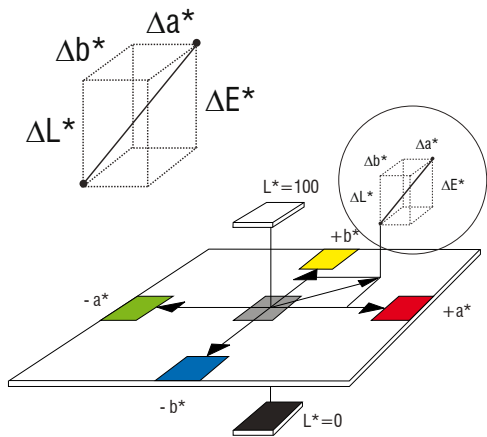

$$\Delta E = \sqrt{(L_p^* - L_v^*)^2 + (a_p^* - a_v^*)^2 + (b_p^* - b_v^*)^2} = 5$$

A ΔE of 5 corresponds roughly to the difference grey 50% ■ and grey 55% ■.

Selection criteria colorSENSOR								
colorSENSOR with fibre optics	LT-1-LC-10	LT-1-LC-20	LT-1-ST	WLCS-M-41	LT-2-ST	LT-2-DU	LT-3-HE	LT-3-LU
Number of colour memories	3	31	15 (255)	4	255	255 (2x15)	31	31
Colour difference	$\Delta E \geq 1.5$	$\Delta E \geq 1.5$	$\Delta E \geq 1.5$	$\Delta E \geq 1.5$	$\Delta E \geq 0.8$	$\Delta E \geq 0.8$	$\Delta E \geq 0.5$	$\Delta E \geq 0.5$
Detection distance	2-100mm	2-100mm	2-100mm	2-150mm	2-200mm	2-200mm	2-200mm	2-200mm
Light spot \varnothing	0.6-20mm	0.6-20mm	0.6-20mm	0.6-30mm	0.6-30mm	0.6-30mm	0.6-30mm	0.6-30mm
Fibre optic + lens	•	•	•	•	•	•	•	•
Teach-in	•		•	•		•	•	•
Button teach	3		3	4		8 (2x4)	31	31
Software		•	•		•	•	•	•
Software teach		31	15 (255)		255	255	31	31
RS 232 interface			•	•	•	•	•	•
USB interface					•	•		
Characteristics of the application	Matt surface	•	•	•	•	•	•	•
	Shiny surface	¹⁾	¹⁾	¹⁾	¹⁾	¹⁾	¹⁾	¹⁾
	Reflective surface							
	Textured surface							
	High temperature to 400 °C	•	•	•	•	•	•	
	Fluorescent surfaces							•
	Large working distance							
	LED test					•	•	•
Page	6-7	8-9	10-11	12-13	14-15	16-17	18-19	20-21

¹⁾ with reservations in connection with KL-D-XX focus lens

colorSENSOR with fixed lenses	OT-3-MA	OT-3-GL	OT-3-HR	OT-3-LD	OT-3-LU			
Number of colour memories	31	31	31	31	31			
Colour difference ΔE	≥ 0.5	≥ 0.5	≥ 0.5	≥ 1.5	≥ 0.5			
Detection distance	10-400mm	10-300mm	10-300mm	200-800mm	10-100mm			
Light spot \varnothing	4-50mm	4-50mm	4-50mm	20-80mm	8-40mm			
Fibre optic + lens								
Teach-in	•	•	•	•	•			
Button teach (colours)	31	31	31	31	31			
Software	•	•	•	•	•			
Software teach (colours)	31	31	31	31	31			
RS 232 interface	•	•	•	•	•			
USB interface								
Characteristics of the application	Matt surface	•	•	•	•			
	Shiny surface		•	•				
	Reflective surface			•				
	Textured surface		•	•				
	High temperature to 400 °C							
	Fluorescent surfaces					•		
	Large working distance				•			
	LED test	•	•	•	•			
Page	22-23	24-25	26-27	28-29	30-31			



- Compact colour sensor
- 3 colours via Teach-in
- 5-fold tolerance adjustment
- Fibre optic with focus lenses

Features:

- Colour memory : 3 (via Teach-in)
- White light LED
- $L^*a^*b^*$ transformation
- True color colour chip
- Several TEACH possibilities (via PC or external)
- Adaption of fibre optic and focus lens
- Robust aluminium housing
- Switching frequency up to 1kHz

Application examples:

- Detection of colour rings on metallic and plastic sleeves
- Reading out and statistically evaluating colour values
- Recognising colour markings in the printing industry
- Colour and grey-scale detection
- Inspection of packaging
- Sorting tasks on the basis of colour (e.g. checking O-rings, closures, crown corks, and labels)
- Colour recognition on interior components (e.g. head supports, ...)

With the aid of a modulated white light LED, a spot of white light is projected directly through an fibre optic to the surface being inspected. Part of the light back-scattered from the object being measured is now focused by fibre optic onto a perceptive True-Colour detector element, sub-divided according to RGB colour values and transformed into $L^*a^*b^*$.

With the LC-10, up to 3 colours can be taught easily via the Teach-in or external teach functions. If a colour that has been taught is recognised by the sensor, a change in switching condition is made via the 3 encoded digital outputs.

Dimensions:

Dimensions in mm, not to scale

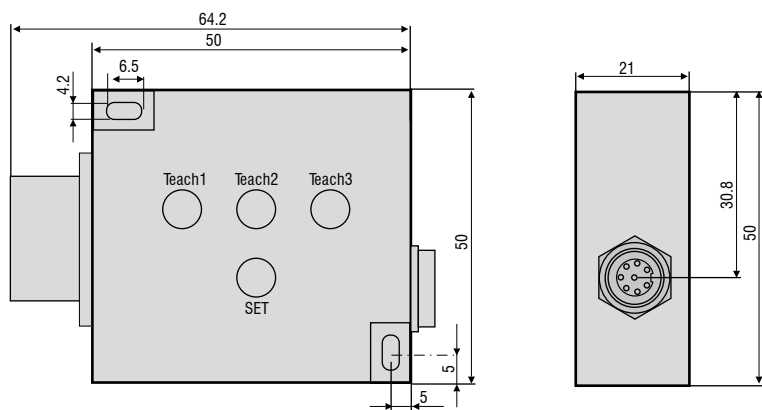

Type	LT-1-LC-10
Article number	10234059
Object distance	dependent on the fibre optics used and the optical heads reflex mode fibre optical cables typically 2mm-15mm with lens, typically 5mm-100mm1)
Light spot diameter	dependent on the fibre optics used and the optical heads \varnothing 0,6mm-20mm 1)
Colour difference	$\Delta E \geq 1.5$
Colour spaces	L*a*b*
Averaging	-
Size of the colour memory	max. 4 colours in non-volatile EEPROM with tolerance level
Switching frequency	max. 1kHz
Reproducibility	3x12-Bit-A/D conversion
Temperature drift X,Y	0.2% /K
Light source	white light LED, AC mode
Type of illumination	via fibre optic
Effect through illumination	suitable for flexibility
Ambient light	up to 5000 Lux
Intermittent light operation	AC: typ. 10kHz
Power supply	+18 - 28VDC
Current consumption	typ. 100mA
Max. switching current	100mA
TEACH button/inputs	4 buttons, Set and IN0 - IN2 for external teaching of the colour reference and tolerance level
Outputs	OUT 0 - OUT 2, digital (0V/+Ub), 100mA max. switching current
Switching state display	visualisation by means of 3 yellow LEDs
Interface	-
Type of connector	to PLC: 8-pole flange socket (binder series 712)
Connection cable	to Power/PLC: art. no. 11234091
Receiver	3-colour filter detector (TRUE COLOR detector, colour filter curve as per CIE 1931)
Software	-
Pulse extension	10ms
Signal amplification	-
Housing material	aluminium, black anodised
Operating temperature	-10°C - +55°C
Storage temperature	-10°C - +85°C
Protection class	IP54
Fibre optic	page 34 onwards

¹⁾ Type: FAR-T-A2.0-2.5-1200-67° reflex type

Type: FAD-T-A2.0-2.5-1200-67° transmitted light (p.36 onwards)



- Compact colour sensor
- 31 colours via software
- 5-fold tolerance adjustment
- Fibre optic with focus lenses

Features:

- Colour memory: 31 (via software)
- RS232 interface
- White light LED
- Colour spaces: X/Y INT; s/i M (Lab)
- True color colour chip
- Several TEACH possibilities (via PC or external)
- A variety of evaluation algorithms can be activated
- Colour grouping
- Adaption of fibre optic and focus lens
- Robust aluminium housing
- Switching frequency up to 35kHz
- colorCONTROL S software

Application examples:

- Detection of colour rings on metallic and plastic sleeves
- Reading out and statistically evaluating colour values
- Recognising colour markings in the printing industry
- Colour and grey-scale detection
- Inspection of packaging
- Sorting tasks on the basis of colour (e.g. checking O-rings, closures, crown corks, and labels)
- Colour recognition on interior components (e.g. head supports, ...)
- LED tests of function, colour and intensity

With the aid of a modulated white light LED, a spot of white light is projected directly through an fibre optic to the surface being inspected. Part of the light back-scattered from the object being measured is now focused by fibre optic onto a perceptive True-Colour detector element, sub-divided according to RGB colour values and transformed into $L^*a^*b^*$.

With the LC-20, 31 colours can be taught using the colorCONTROL S software. If a colour that has been taught is recognised by the sensor, a change in switching condition is made via the 5 encoded digital outputs.

Dimensions:

Dimensions in mm, not to scale

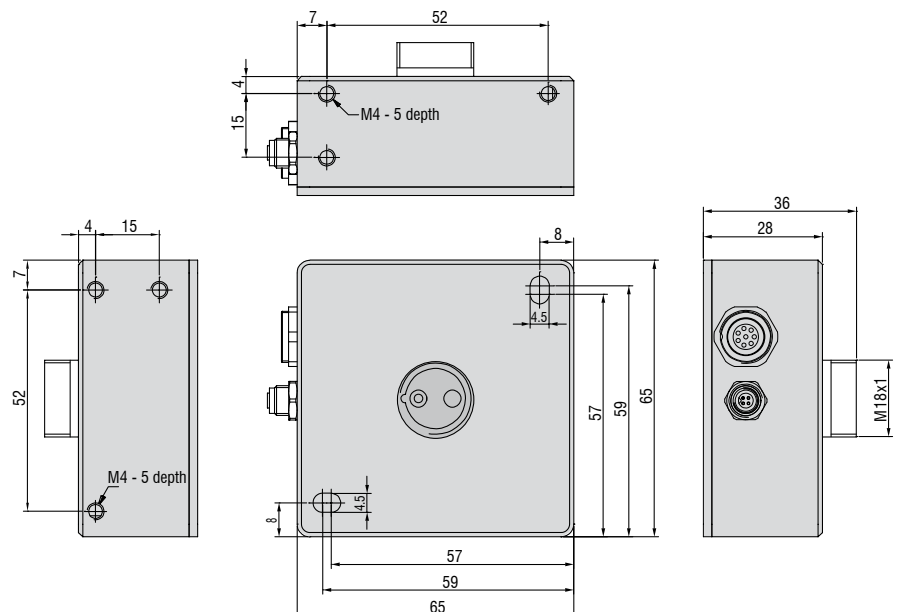

Type	LT-1-LC-20
Article number	10234060
Object distance	dependent on the fibre optics used and the optical heads reflex mode fibre optical cables typically 2mm-15mm with lens, typically 5mm-100mm ¹⁾
Light spot diameter	dependent on the fibre optics used and the optical heads reflex mode fibre optical cables, typically Ø 0.6mm-20mm ¹⁾
Colour difference	$\Delta E \geq 1.5$
Colour spaces	X/Y INT; s/i M (Lab)
Averaging	more than max. 32768 values
Size of the colour memory	max. 31 colours in non-volatile EEPROM with parameter sets
Switching frequency	max. 35kHz (depending on number of colours being taught and the setting for the averaging)
Reproducibility	in the x,y colour range, 1 digit each with 12-Bit-A/D conversion
Temperature drift X,Y	< 0.01% K
Light source	super-bright white light LED, AC or DC or PULSE mode (adjustable or OFF for self-luminous objects, software-switchable)
Type of illumination	via fibre optic
Effect through illumination	suitable for flexibility
Ambient light	up to 5000Lux (in AC and PULSE mode)
Intermittent light operation	AC: typ. to 20kHz (depending on amplification level AMP1 to AMP8) DC: typ. to 35kHz PULSE mode: typ. to 5kHz
Power supply	+24VDC ($\pm 10\%$), inverse polarity protected, overload-proof
Current consumption	< 160mA
Max. switching current	100mA, short-circuit protected
TEACH button/inputs	no button for external teaching of the colour references apart from IN0
Outputs	OUT 0 - OUT 4, digital (0V/+Ub), short-circuit protected, 100 mA max. switching current npn-, pnp-capable (bright or dark switching, switchable)
Switching state display	-
Interface	RS232
Type of connector	to PLC: 8-pole flange socket (binder series 712) to PC: 8-pole flange socket (binder series 712)
Connection cable	to power/PLC: art. no. 11234091 / to PC: 11234095 (RS232); 11234096 (USB)
Receiver	3-colour filter detector (TRUE COLOR detector, colour filter curve as per CIE 1931)
Software	colorCONTROL S
Pulse extension	adjustable 0ms-100ms
Signal amplification	8 stage (AMP1 - AMP8), adjustable
Housing material	aluminium, black anodised
Operating temperature	-20°C - +55°C
Storage temperature	-20°C - +85°C
Protection class	IP54
EMC test according	DIN EN 60947-5-2
Fibre optic	page 34 onwards

¹⁾ Typ: FAR-T-A2.0-2,5-1200-67° reflex

Typ: FAD-T-A2.0-2,5-1200-67° transmitted light (p. 36 onwards)



- Compact True color recognition sensor

- 255 colours can be saved

- Teach-in (3 colours)

- PC programmable via RS232

- Fibre optic with focus lenses

- Adjustable illumination

Features:

- Colour memory: 3 (Teach-In buttons), 255 (software)
- max. 4 colour channels (15 with binary coding)
- RS232 interface
- White light LED
- $L^*a^*b^*$ / $L^*u^*v^*$ transformation
- A variety of evaluation algorithms can be activated
- 15 colour grouping are possible
- Adaption of fibre optic and focus lens
- Robust aluminium housing
- Switching frequency to 10kHz
- colorCONTROL LT software
- Recording of colour values by means of Colour Watcher software

Application examples:

- Detection of colour rings on metallic and plastic sleeves
- Reading out and statistically evaluating colour values
- Recognising colour markings in the printing industry
- Colour and grey-scale detection
- Inspection of packaging
- Sorting tasks on the basis of colour (e.g. checking O-rings, closures, crown corks, and labels)
- Colour recognition on interior components (e.g. head supports, ...)

Dimensions:

Dimensions in mm, not to scale

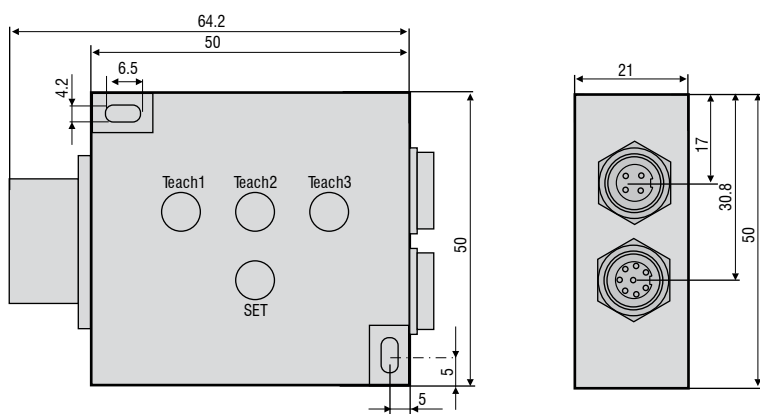

Typ	LT-1-ST
Article number	10234061
Object distance	dependent on the fibre optics used and the optical heads reflex mode fibre optical cables typically 2mm-25mm with lens, typically 5mm-100mm ¹⁾
Light spot diameter	dependent on the fibre optics used and the optical heads reflex mode fibre optical cables, typically 0.6mm-20mm ¹⁾
Colour difference	$\Delta E \geq 1.5$
Colour spaces	XYZ, xyY, $L_{99}a_{99}b_{99}$, $L^*a^*b^*$, $L^*u^*v^*$, $u^*v^*L^*$
Averaging	more than max. 57600 values
Size of the colour memory	max. 255 colours in non-volatile EEPROM with parameter sets
Switching frequency	max. 10kHz (depending on number of colours being taught and the setting for the averaging)
Reproducibility	3x12-Bit-A/D conversion
Temperature drift X,Y	0.2%/K
Light source	white light LED, AC mode (adjustable or OFF for self-luminous objects, software-switchable)
Type of illumination	via fibre optics
Effect through illumination	suitable for flexibility
Ambient light	up to 5000 Lux
Intermittent light operation	AC: typ. to 10kHz
Power supply	+18 - 28VDC
Current consumption	typ. 100mA
Max. switching current	100mA
TEACH button/inputs	4 buttons, Set and IN0 - IN2 for external teaching of the colour reference and tolerance level
Outputs	OUT 0 - OUT 2, digital (0V/+Ub), 100mA max. switching current
Switching state display	visualisation by means of 3 yellow LEDs
Interface	RS232
Type of connector	to PLC: 8-pole flange socket (binder series 712) to PC: 4-pole flange socket (binder series 712)
Connection cable	to power/PLC: art. no. 11234091 / to PC: art. no. 11234093 (RS232)
Receiver	3-colour filter detector (TRUE COLOR detector, colour filter curve as per CIE 1931)
Software	colorCONTROL LT
Pulse extension	adjustable 0ms-100ms
Signal amplification	-
Housing material	aluminium, black anodised
Operating temperature	-10°C - +55°C
Storage temperature	-10°C - +85°C
Protection class	IP54
Fibre optic	page 34 onwards

¹⁾ Type: FAR-T-A2.0-2.5-1200-67° reflex

Type: FAD-T-A2.0-2.5-1200-67° transmitted light (p.36 onwards)



- The all-round talent for colour recognition
- 4 colour memory „Teach-in“
- Fibre optic with focus lenses to 100mm
- Colour and intensity evaluation
- High colour resolution
- „Plug & Play“ operating concept

Features:

- Multi-Teach by buttons on the sensor
- Separation of sensor and sampling point (explosion-protected for hazardous areas)
- Switch Output, 4x potential-free
- Adaption of fibre optics for every application
- Working distance 2-100mm, depending on fibre optic and lens
- Protection class IP65
- Solid enclosure concept for rugged industrial applications
- Independent of distance due to colour and intensity evaluation (C and C+ I)
- Resolution
 - Colour \leq 12bit
 - Intensity \leq 12bit
- External teaching
 - Perceptive colour processing
 - White light LED as light source
 - RS232 interface
 - 4 colour grouping can be saved
 - Four-stage signal amplification
 - Colour spaces: C, C+I

Advantages:

- Application-oriented teaching of tolerances through „multiple teaching“ per channel
- Separate tolerance setting via potentiometer for each colour memory is also possible
- Genuine three sector device
- Fibre optic adaption
- Universal operation
- No selectivity gaps in the colour range

Application examples:

- Colour sorting and inspection
- Recognising similar colours
- Recording colour codes
- Recognising positions
- Recognising locking compounds
- All colour recognition tasks (between 390 and 750nm)
- Recognition of intensity

Dimensions:

Dimensions in mm, not to scale

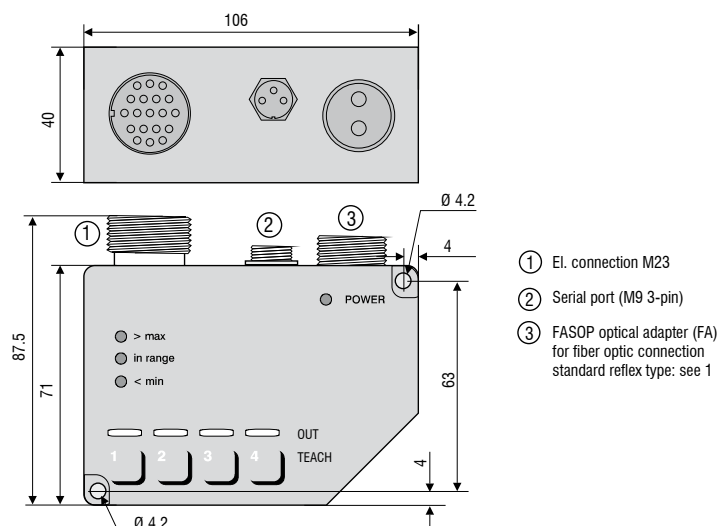

Type	WLCS-M-41
Article number	10234062
Object distance	dependent on the fibre optics used and the optical heads reflex mode fibre optical cables typically 2mm-25mm with lens, typically 5mm-150mm ¹⁾
Light spot diameter	dependent on the fibre optics used and the optical heads reflex mode fibre optical cables, typically Ø 0.6mm-30mm ¹⁾
Colour difference	$\Delta E \geq 1.5$
Colour spaces	C, C+I
Averaging	more than 32 values
Size of the colour memory	max. 4 colours in non-volatile EEPROM with tolerance level via potentiometer
Switching frequency	1kHz, 32Hz with averaging
Reproducibility	in the C+I colour range ≤ 12 Bit-A/D conversion
Temperature drift X,Y	0.1% / K
Light source	white light LED, AC mode
Type of illumination	via fibre optic
Effect through illumination	suitable for flexibility
Ambient light	up to 5000Lux
Intermittent light operation	AC: typ. 20kHz
Power supply	+18 - 30VDC
Current consumption	typ. 240mA
Max. switching current	240mA
TEACH button/inputs	4 buttons and IN1 - IN4 for external teaching of the colour reference
Outputs	OUT 1-OUT 4, digital (0V/+Ub), short-circuit protected, 100mA max. switching current
Switching state display	visualisation by means of 4 yellow LEDs
Interface	RS232
Type of connector	to PLC: 19-pole flange socket (Harting) to PC: 3-pole flange socket
Connection cable	to power/PLC: art no. 11234089 / to PC: art. no. 11234090 (RS232)
Receiver	3-PIN photodiodes with colour filter
Software	-
Pulse extension	-
Signal amplification	-
Housing material	aluminium, black anodised
Operating temperature	0°C - +50°C
Storage temperature	0°C - +80°C
Protection class	IP65
Fibre optic	p. 34 onwards

¹⁾ Type: FAR - T - A2.0-2.5-1200-67° reflex

Type: FAD - T - A2.0-2.5-1200-67° transmitted light (p. 36 onwards)



- Standard colour sensor
- 255 colours can be saved
- Perceptive colour sensor system
- PC programmable via RS232 / USB
- Fibre optic with focus lenses
- Distinguishing colours like the human eye

Features:

- Colour memory: up to 255 colours
- RS232/ USB interface
- White light LED
- $L^*a^*b^*$ / $L^*u^*v^*$ / DIN99 transformation
- Can be re-calibrated
- Switchable for LED recognition
- Several TEACH possibilities (via PC or external)
- A variety of evaluation algorithms can be activated
- Colour grouping
- Adaption of FASOP fibre optic and focus lenses
- Robust aluminium housing
- Switching frequency up to 15kHz
- colorCONTROL LT software

Application examples:

- Quality assurance
- Reading out and statistically evaluating colour values
- Recognising colour markings in the printing industry
- Colour and grey-scale detection
- Recognising the degree of browning with bakery products
- Inspection of packaging
- Sorting tasks on the basis of colour (e.g. checking O-rings, closures, crown corks, and labels)
- Colour recognition on vehicle body parts, bumpers, doors, etc.
- LED tests of function, colour and intensity

Dimensions:

Dimensions in mm, not to scale

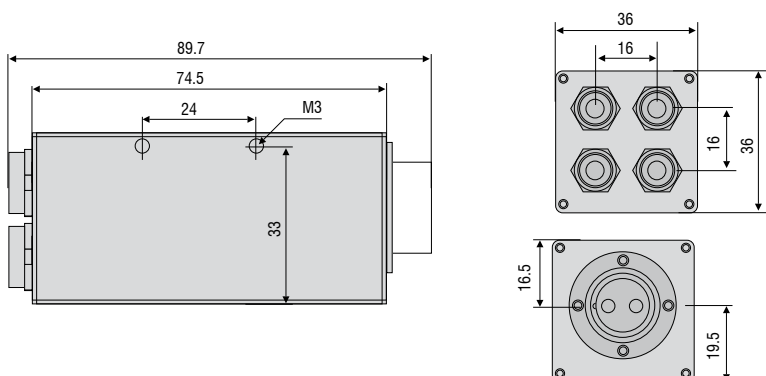

Type	LT-2-ST
Article number	10234063
Object distance	dependent on the fibre optics used and the optical heads reflex optics fibre typ. 2mm-25mm with lens, typ. 5mm-200mm ¹⁾
Light spot diameter	dependent on the fibre optics used and the optical heads reflex fibre optic typ. Ø 0.6mm-30mm ¹⁾
Colour difference	$\Delta E \geq 0.8$
Colour spaces	XYZ, xyY, $L_{99}a_{99}b_{99}$, $L^*a^*b^*$, $L^*u^*v^*$, $u^*v^*L^*$
Averaging	more than max. 57600 values
Size of the colour memory	max. 255 colours in non-volatile EEPROM with parameter sets
Switching frequency	max. 15kHz (depending on number of colours being taught and the setting for the averaging)
Reproducibility	3x12-Bit-A/D conversion
Temperature drift X,Y	0.2% /K
Light source	2x white light LED, AC mode (adjustable or OFF for self-luminous objects, software-switchable) ²⁾
Type of illumination	via fibre optic
Effect through illumination	suitable for flexibility
Ambient light	to 5000Lux
Intermittent light operation	AC: typically to 15kHz (depending on 4 amplification levels)
Power supply	+18 - 28VDC
Current consumption	typ. 500mA
Max. switching current	100mA
TEACH button/inputs	no button for external teaching of the colour references apart from IN0 - IN1
Outputs	OUT 0 - OUT 7, digital (0V/+Ub), 100 mA max. switching current
Switching state display	-
Interface	RS232, USB 2.0
Type of connector	to PLC: 8-pole flange socket (binder series 712) to PC: 4-pole flange socket (binder series 712)
Connection cable	to power/PLC: 2 x art. no. 11234091 / to PC: art. no. 11234093 (RS232); 11234094 (USB)
Receiver	3-colour filter detector (TRUE COLOR detector, colour filter curve as per CIE 1931)
Software	colorCONTROL LT
Pulse extension	adjustable 0ms-100ms
Signal amplification	4 levels (1, 5, 25, and 100)
Housing material	aluminium, black anodised
Operating temperature	-10 °C - +55°C
Storage temperature	-10 °C - +85°C
Protection class	IP65
Fibre optic	p. 34 onwards

¹⁾ Type: FAR - T - A2.0-2.5-1200-67° reflex

Type: FAD - T - A2.0-2.5-1200-67° transmitted light (p. 36 onwards)

²⁾ suitable for LED testing



- 2-channel colour sensor
- 255 colours can be saved
- Teach-in (8 colours)
- PC programmable via RS232 / USB
- Fibre optic with focus lenses
- Distinguishing colours like the human eye

Features:

- Colour memory: 8 (Teach-in) 255 (software)
- 2x White light LED
- RS232 and USB 2.0 interface
- Colour spaces: XYZ, xyY, $L_{99}a_{99}b_{99}$, $L^*a^*b^*$, $L^*u^*v^*$, $u'v'L^*$
- Switchable for LED recognition
- Several TEACH possibilities (via PC or external)
- Difference / reference / 2-channel mode
- Adaption of FASOP fibre optic and focus lens
- Logical link, deviation mode
- Switching frequency to 15kHz
- Perceptive colour processing
- Six teach buttons on the housing
- 4 stage signal amplification
- colorCONTROL LT software

Application examples:

- Quality assurance
- Reading out and statistically evaluating colour values
- Detection of colour rings on metallic and plastic sleeves
- Recognising colour markings in the printing industry
- Colour and grey-scale detection
- Checking colour gradients
- Checking colour transitions
- Checking colour deviations
- Inspection of packaging
- Colour recognition on vehicle body parts, bumpers, doors, etc.
- LED tests of function, colour and intensity

Dimensions:

Dimensions in mm, not to scale

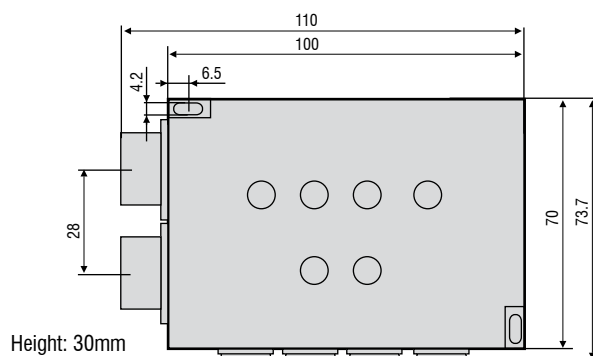

Type	LT-2-DU
Article number	10234064
Object distance	dependent on the fibre optics used and the optical heads reflex mode fibre optical cables typically 2mm-25mm with lens, typically 5mm-200 mm ¹⁾
Light spot diameter	dependent on the fibre optics used and the optical heads reflex fibre optic typ. Ø 0.6mm-30mm ¹⁾
Colour difference	$\Delta E \geq 0.8$
Colour spaces	XYZ, xyY, $L_{99}a_{99}b_{99}$, $L^*a^*b^*$, $L^*u^*v^*$, $u^*v^*L^*$
Averaging	more than max. 57600 values
Size of the colour memory	max. 255 colours in non-volatile EEPROM with parameter sets
Switching frequency	max. 15kHz (depending on number of colours being taught and the setting for the averaging)
Reproducibility	3x12-Bit-A/D conversion
Temperature drift X,Y	0.2% /K
Light source	2x white light LED, 2x white light LED, AC mode (adjustable or OFF for self-luminous objects, software-switchable) ²⁾
Type of illumination	via fibre optic
Effect through illumination	suitable in flexibility
Ambient light	to 5000Lux
Intermittent light operation	AC: typically to 15kHz (depending on 4 amplification levels)
Power supply	+18 - 28VDC
Current consumption	typ. 500mA
Max. switching current	100mA
TEACH button/inputs	6 buttons, Tol, Lo/Hi and IN0/4 - IN3/8 for external teaching of the colour reference and tolerance level
Outputs	OUT 0 - OUT 7, digital (0V/+Ub), 100mA max. switching current
Switching state display	visualisation by means of 3 yellow LEDs
Interface	RS232, USB 2.0
Type of connector	to PLC: 8-pole flange socket (binder series 712) to PC: 4-pole flange socket (binder series 712)
Connection cable	to power/PLC: 2 x art no. 11234091 / to PC: art no. 11234093 (RS232); 11234094 (USB)
Receiver	2x3-colour filter detector (TRUE COLOR detector, colour filter curve as per CIE 1931)
Software	colorCONTROL LT
Pulse extension	adjustable 0ms-100ms
Signal amplification	4 levels (1, 5, 25 and 100)
Housing material	aluminium, black anodised
Operating temperature	-10 °C - +55°C
Storage temperature	-10 °C - +85°C
Protection class	IP54
Fibre optic	p. 34 onwards

¹⁾ Type: FAR-T-A2.0-2.5-1200-67° reflex

Type: FAD-T-A2.0-2.5-1200-67° transmitted light (p. 36 onwards)

²⁾ suitable for LED testing



- High-end colour sensor
- 31 colours can be saved
- Fibre optic adaption
- Colour and grey scale evaluation
- PC programmable via RS232 / USB

Features:

- Colour memory: 31 colours per Teach-in and software
- RS232 interface (USB adapter optional)
- Modulated white light LED (can be connected for external super-bright white light source)
- Switchable brightness readjustment
- Colour and grey-scale detection
- Switchable averaging
- A variety of evaluation algorithms can be activated
- Switching frequency max. 30kHz
- Switching state display
- Temperature compensation <0.01%/K
- Eight-stage signal amplification, adjustable
- Colour spaces: X/Y INT; s/i M (Lab)

Application examples:

- Detection of colour rings
- Recognising colour markings in the printing industry
- Inspection of packaging
- Sorting tasks on the basis of colour
- Colour recognition on interior components
- Colour control of self-luminous objects (LEDs, displays, etc.)

Dimensions:

Dimensions in mm, not to scale

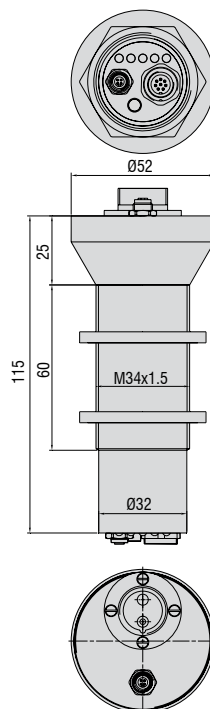

Type	LT-3-HE
Article number	10234065
Object distance	dependent on the fibre optics used and the optical heads reflex fibre optic typ. 2mm-25mm with lens typ. 5mm-200mm ¹⁾
Light spot diameter	dependent on the fibre optics used and the optical heads reflex fibre optic typ. Ø 0.6mm-30mm ¹⁾
Colour difference	$\Delta E \geq 0.5$
Colour spaces	X/Y INT; s/i M (Lab)
Averaging	more than max. 32768 values
Size of the colour memory	max. 31 colours in non-volatile EEPROM with parameter sets
Switching frequency	max. 30kHz (depending on number of colours being taught and the setting for the averaging)
Reproducibility	In the x,y colour range, 1 digit each with 12-Bit-A/D conversion
Temperature drift X,Y	< 0.01% /K
Light source	super-bright white light LED, AC or DC, (adjustable or OFF for self-luminous objects, software-switchable) ²⁾
Type of illumination	via fibre optic
Effect through illumination	suitable for flexibility
Ambient light	to 5000Lux (AC-mode)
Intermittent light operation	AC: typ. 10kHz to 40kHz (depending on amplification level AMP1 to AMP8) DC: switchable by PC software
Power supply	+24VDC ($\pm 10\%$), inverse polarity protected, overload-proof
Current consumption	typ. 320mA
Max. switching current	100mA, short-circuit protected
TEACH button/inputs	1 button and IN0 for external teaching of the colour references
Outputs	OUT 0 - OUT 4, digital (0V/+Ub), short-circuit protected, 100mA max. switching current npn-, pnp-capable (bright or dark switching, switchable)
Switching state display	visualisation by means of 5 yellow LEDs
Interface	RS232 (optional USB)
Type of connector	to PLC: 8-pole flange socket (binder series 712) to PC: 4-pole flange socket (binder series 707)
Connection cable	to power/PLC: art. no. 11234091 / to PC: art. no 11234095 (RS232); 11234096 (USB).
Receiver	3-colour filter detector (TRUE COLOR detector, colour filter curve as per CIE 1931)
Software	colorCONTROL S
Pulse extension	adjustable 0ms-100ms
Signal amplification	8 stage (AMP1 - AMP8), adjustable
Housing material	aluminium, black anodised
Operating temperature	-20°C - +55°C
Storage temperature	-20°C - +85°C
Protection class	IP67 (lens), IP64 (electronics)
EMC test according	DIN EN 60947-5-2
Fibre optic	p. 34 onwards

¹⁾ Type: FAR-T-A2.0-2.5-1200-67° reflex

Type: FAD-T-A2.0-2.5-1200-67° transmitted light (p. 36 onwards)

²⁾ suitable for LED testing



- High-end colour sensor for fluorescent objects
- 31 colours can be saved
- Adaption of UV-light capable fibre optics
- Colour and grey scale evaluation
- Detection of luminescent colours
- PC programmable via RS232 / USB

Features:

- Colour memory: 31 colours per Teach-in and software
- RS232 interface (USB adapter optional)
- Modulated white light LED (385nm) (can be connected for external super-bright white light source)
- Switchable brightness readjustment
- Colour and grey-scale detection
- Switchable averaging
- A variety of evaluation algorithms can be activated
- Switching frequency max. 30kHz
- Switching state display
- UV fibre optic available
- colorCONTROL S software

Application examples:

- Detection of luminescent colours
- Recognising colour markings in the printing industry
- Inspection of packaging
- Sorting tasks on the basis of colour

Dimensions:

Dimensions in mm, not to scale

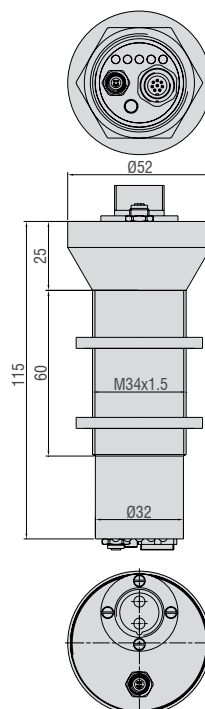

Type	LT-3-LU
Article number	10234066
Object distance	dependent on the fibre optics used and the optical heads reflex fibre optic typ. 2mm-25mm with lens typ. 5mm-50mm ¹⁾
Light spot diameter	dependent on the fibre optics used and the optical heads ¹⁾
Colour difference	$\Delta E \geq 0.5$
Colour spaces	X/Y INT; s/i M (Lab)
Averaging	more than max. 32768 values
Size of the colour memory	max. 31 colours in non-volatile EEPROM with parameter sets
Switching frequency	max. 30kHz (depending on number of colours being taught and the setting for the averaging)
Reproducibility	in the x,y colour range, 1 digit each with 12-Bit-A/D conversion
Temperature drift X,Y	< 0.01% /K
Light source	super-bright UV LED, 385nm, AC-, DC mode, (adjustable or OFF for self-luminous objects, software-switchable)
Type of illumination	via fibre optic
Effect through illumination	suitable for flexibly recognising luminescent colours
Ambient light	to 5000 Lux (AC mode)
Intermittent light operation	AC: typ. 10kHz to 40kHz (depending on amplification level AMP1 to AMP8) DC: switchable by PC software
Power supply	+24VDC ($\pm 10\%$), inverse polarity protected, overload-proof
Current consumption	typ. 320mA
Max. switching current	100mA, short-circuit protected
TEACH button/inputs	1 button and IN0 for external teaching of the colour references
Outputs	OUT 0 - OUT 4, digital (0V/+Ub), short-circuit protected, 100mA max. switching current npn-, pnp-capable (bright or dark switching, switchable)
Switching state display	visualisation by means of 5 yellow LEDs
Interface	RS232 (optional USB)
Type of connector	to PLC: 8-pole flange socket (binder series 712) to PC: 4-pole flange socket (binder series 707)
Connection cable	to power/PLC: art. no. 11234091 / to PC: art. no. 11234095 (RS232); 11234096 (USB).
Receiver	3-colour filter detector (TRUE COLOR detector, colour filter curve as per CIE 1931)
Software	colorCONTROL S
Pulse extension	adjustable 0ms-100ms
Signal amplification	8 stage (AMP1 - AMP8), adjustable
Housing material	aluminium, black anodised
Operating temperature	-20°C - +55°C
Storage temperature	-20°C - +85°C
Protection class	IP67 (lens), IP64 (electronics)
EMC test according	DIN EN 60947-5-2
Fibre optic	p. 34 onwards

¹⁾ Type: FAR - T - A2.0-2.5-1200-67° - UV reflex
FAD - T - A2.0-2.5-1200-67° - UV transmitted light



- Colour sensor for large distances and matt surfaces

- 31 colours can be saved

- Focused illumination for rapidly changing object distances

- Colour and grey scale evaluation

- PC programmable via RS232

Features:

- White light LED ring, focused, with clear glass covering
- Object distance typ. 10mm - 400mm
- Large dynamic range through focused white light operation
- Colour memory: 31 colours per Teach-in and software
- RS232 interface (USB adapter optional)
- Switchable brightness readjustment
- Switching frequency max. 30kHz
- A variety of evaluation algorithms can be activated, e.g. „BEST HIT“ mode
- Switching state display via 5 yellow LEDs
- Switchable averaging
- Colour control of self-luminous objects

Application examples:

- Colour recognition of matt surfaces at a distance of up to 400mm
- Detection of colour rings
- Recognising colour markings in the printing industry
- Inspection of packaging
- Sorting tasks on the basis of colour
- Colour control of self-luminous objects (LEDs, displays, etc.)
- Illumination recognition as per colour and intensity

colorSENSOR OT colour sensors are fixed lens sensors with True-Colour detection. The sensor automatically illuminates the surface with white light and records the reflected colour values. Aside from the optics, the models are almost identical. The illumination can be disabled by software. OT sensors are then suitable for the colour detection of self-luminous sources.

Dimensions:

Dimensions in mm, not to scale

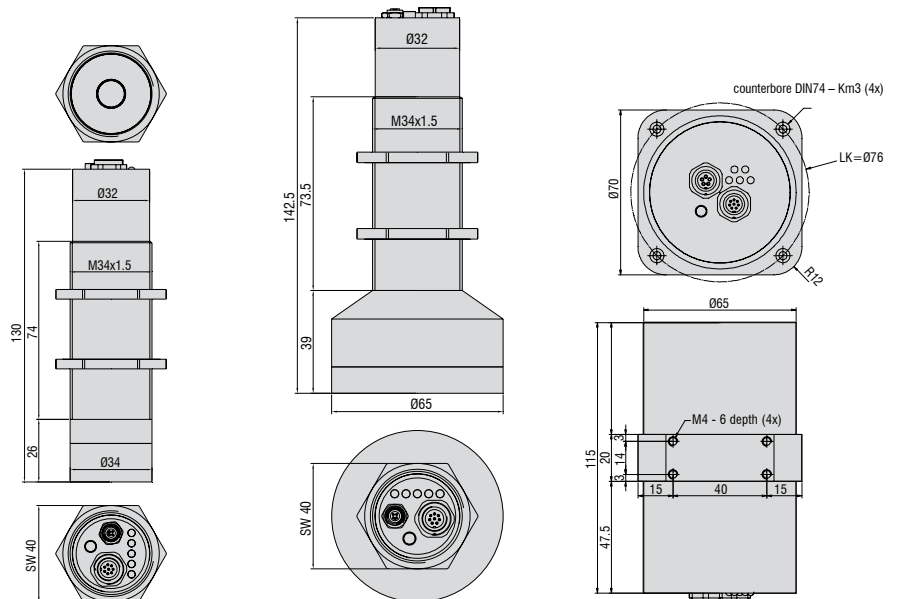

OT-3-MA-30-8/OT-3-MA-30-16
OT-3-MA-50-12.5/OT-3-MA-50-25

OT-3-MA-80-36

OT-3-MA-200-20

Type	OT-3-MA-30-8	OT-3-MA-30-16	OT-3-MA-50-12.5	OT-3-MA-50-25	OT-3-MA-80-36	OT-3-MA-200-20
Article number	10234067	10234068	10234069	10234070	10234071	10234072
Object distance	typ. 10mm-100mm ideal distance 30mm		typ. 20mm-120mm ideal distance 50mm		typ. 40mm-150mm ideal distance 80mm	typ. 50mm-400mm ideal distance 200mm
Light spot	Ø 5-16mm	Ø 10-31mm	Ø 4-24mm	Ø 8-48mm	Ø 30-48mm	Ø 5-40mm
Light spot diameter	Ø 8mm at 30mm	Ø 16mm at 30mm	Ø 12.5mm at 50mm	Ø 25mm at 50mm	Ø 36mm at 80mm	Ø 20mm at 200mm
Colour difference	ΔE ≥ 0.5					ΔE ≥ 1.5
Colour spaces	X/Y INT; s/i M (Lab)					
Averaging	more than max. 32768 values					
Size of the colour memory	max. 31 colours in non-volatile EEPROM with parameter sets					
Switching frequency	max. 30kHz (depending on number of colours being taught and the setting for the averaging)					
Reproducibility	in the x,y colour range, 1 digit each with 12-Bit-A/D conversion					
Temperature drift X,Y	< 0.01% /K					
Light source	8x white light LED, AC-, DC mode ¹⁾ (adjustable or OFF for self-luminous objects, software-switchable)				12x white light LED, AC-, DC mode ¹⁾ (adjustable bzw. OFF for self-luminous objects, software-switchable)	10x white light LED, modulated 30kHz
Type of illumination	focused					
Effect through illumination	large dynamic range for matt/dark surfaces					
Ambient light	to 5000Lux (AC mode)					to 5000Lux
Intermittent light operation	AC: typ. 10kHz to 40kHz (depending on amplification level AMP1 to AMP8) DC: switchable by PC software					30kHz
Power supply	+24VDC (± 10%), inverse polarity protected, overload-proof					
Current consumption	typ. 320mA					
Max. switching current	100mA, short-circuit protected					
TEACH button/inputs	1 button and IN0 for external teaching of the colour references					
Outputs	OUT 0 - OUT 4, digital (0V/+Ub), short-circuit protected, 100mA max. switching current npn-, pnp-capable (bright or dark switching, switchable)					
Switching state display	visualisation by means of 5 yellow LEDs					
Interface	RS232 (optional USB)					
Type of connector	to PLC: 8-pole flange socket (binder series 712) to PC: 4-pole flange socket (binder series 707)					to PLC: 8-pole flange socket (binder 712) to PC: 5-pole flange socket (binder 712)
Connection cable	to power/PLC: art. no. 11234091 / to PC: art. no 11234095 (RS232); 11234096 (USB).					to power/PLC: art. no. 11234091 to PC: art. no. 11234092
Receiver	3-colour filter detector (TRUE COLOR detector, colour filter curve as per CIE 1931)					
Software	colorCONTROL S					colorCONTROL C4
Pulse extension	adjustable 0ms-100ms					
Signal amplification	8 stage (AMP1 - AMP8), adjustable					-
Housing material	aluminium, black anodised					
Operating temperature	-20°C - +55°C					
Storage temperature	-20°C - +85°C					
Protection class	IP67 (lens), IP64 (electronics)					IP64
EMC test according	DIN EN 60947-5-2					

¹⁾ suitable for illumination testing



- Colour sensor for non-homogeneous surfaces and shine suppression
- 31 colours can be saved
- Diffuse illumination for the reduction of the shine effect
- Colour and grey scale evaluation
- PC programmable via RS232 / USB

Features:

- White light LED ring with diffusor and clear glass covering
- Object distance typ. 10mm - 300mm
- Suppression of the shine effect through diffuse illumination
- Colour memory: 31 colours via Teach-in and software
- RS232 interface (USB adapter optional)
- Insensitive to external light up to 5000Lux
- Switchable brightness readjustment
- Switching frequency max. 30kHz
- A variety of evaluation algorithms can be activated, e.g. „BEST HIT“ mode
- Switching state display via 5 yellow LEDs
- Switchable averaging
- Colour control of self-luminous objects

Application examples:

- Colour recognition of textured and/or shiny surfaces
- Detection of colour rings
- Recognising colour markings in the printing industry
- Inspection of packaging
- Sorting tasks on the basis of colour
- Colour control of self-luminous objects (LEDs, displays, etc.)

Dimensions:

Dimensions in mm, not to scale

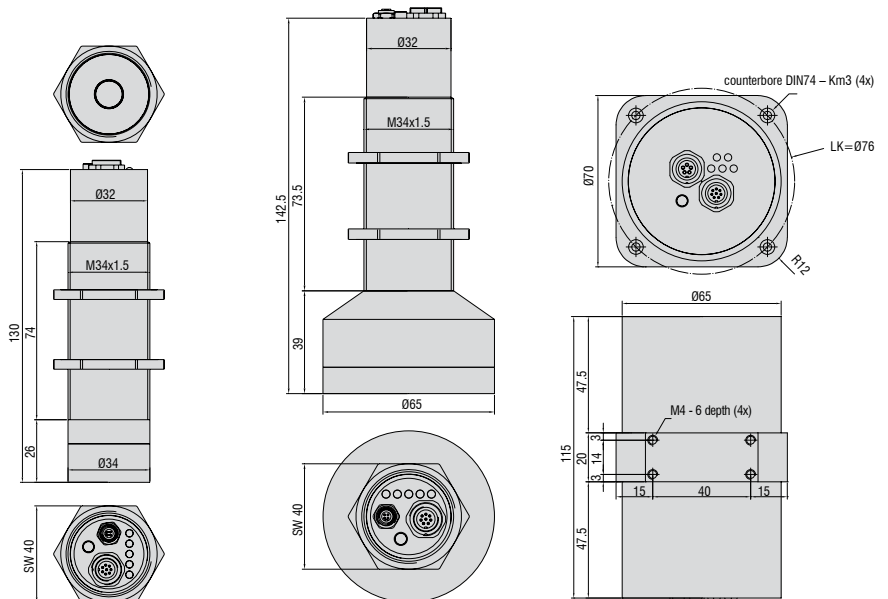

OT-3-GL-30-8/OT-3a-GL-30-16
OT-3-GL-50-12.5/OT-3-GL-50-25

OT-3-GL-80-36

OT-3-GL-200-20

Type	OT-3-GL-30-8	OT-3-GL-30-16	OT-3-GL-50-12.5	OT-3-GL-50-25	OT-3-GL-80-36	OT-3-GL-200-20
Article number	10234073	10234074	10234075	10234076	10234077	10234078
Object distance	typ. 10mm-60mm ideal distance 30mm		typ. 20mm-80mm ideal distance 50mm		typ. 40mm-100mm ideal distance 80mm	typ. 50mm-300mm ideal distance 200mm
Light spot	Ø 4-14mm	Ø 8-28mm	Ø 5-20mm	Ø 10-40mm	Ø 30-40mm	Ø 5-30mm
Light spot diameter	Ø 8mm at 30mm	Ø 16mm at 30mm	Ø 12.5mm at 50mm	Ø 25mm at 50mm	Ø 36mm at 80mm	Ø 20mm at 200mm
Colour difference	$\Delta E \geq 0.5$					$\Delta E \geq 1.5$
Colour spaces	X/Y INT; s/i M (Lab)					
Averaging	more than max. 32768 values					
Size of the colour memory	max. 31 colours in non-volatile EEPROM with parameter sets					
Switching frequency	max. 30kHz (depending on number of colours being taught and the setting for the averaging)					
Reproducibility	in the x,y colour range, 1 digit each with 12-Bit-A/D conversion					
Temperature drift X,Y	< 0.01% /K					
Light source	8x white light LED, AC-, DC mode (adjustable or OFF for self-luminous objects, software-switchable)				12x white light LED, AC-, DC mode (adjustable or OFF for self-luminous objects, software-switchable)	10x white light LED, modulated 30kHz
Type of illumination	diffuse					
Effect through illumination	suppression of the shine effect					
Ambient light	to 5000Lux (AC mode)					to 5000Lux
Intermittent light operation	AC: typ. 10kHz to 40kHz (depending on amplification level AMP1 to AMP8) DC: switchable by PC software					30kHz
Power supply	+24VDC ($\pm 10\%$), inverse polarity protected, overload-proof					
Current consumption	typ. 320mA					
Max. switching current	100mA, short-circuit protected					
TEACH button/inputs	1 button and IN0 for external teaching of the colour references					
Outputs	OUT 0 - OUT 4, digital (0V/+Ub), short-circuit protected, 100mA max. switching current npn-, pnp-capable (bright or dark switching, switchable)					
Switching state display	visualisation by means of 5 yellow LEDs					
Interface	RS232 (optional USB)					
Type of connector	to PLC: 8-pole flange socket (binder series 712) to PC: 4-pole flange socket (binder series 707)					to PLC: 8-pole flange socket (binder 712) to PC: 5-pole flange socket (binder 712)
Connection cable	to power/PLC: art. no. 11234091 to PC: 11234095 (RS232); art. no. 11234096 (USB)					to power/PLC: 11234091 to PC: art. no. 11234092
Receiver	3-colour filter detector (TRUE COLOR detector, colour filter curve as per CIE 1931)					
Software	colorCONTROL S					colorCONTROL C4
Pulse extension	adjustable 0ms-100ms					
Signal amplification	8 stage (AMP1 - AMP8), adjustable					-
Housing material	aluminium, black anodised					
Operating temperature	-20°C - +55°C					
Storage temperature	-20°C - +85°C					
Protection class	IP67 (lens), IP64 (electronics)					IP64
EMC test according	DIN EN 60947-5-2					



- Colour sensor for reflective and textured surfaces
- 31 colours can be saved
- Polarised illumination for highly reflective surfaces
- Colour and grey scale evaluation
- PC programmable via RS232

Features:

- White light LED ring with polarisation filter and clear glass covering
- Object distance typ. 10mm - 300mm
- Polarisation filter (significant reduction of the shine effect)
- Colour memory: 31 colours via Teach-in and software
- RS232 interface (USB adapter optional)
- Insensitive to external light up to 5000Lux
- Switchable brightness readjustment
- Switching frequency max. 30kHz
- A variety of evaluation algorithms can be activated, e.g. „BEST HIT“ mode
- Switching state display via 5 yellow LEDs
- Switchable averaging
- Colour control of self-luminous objects

Application examples:

- Colour recognition of highly reflective and/or highly textured surfaces
- Detection of colour rings
- Recognising colour markings in the printing industry
- Inspection of packaging
- Sorting tasks on the basis of colour
- Colour control of self-luminous objects (LEDs, displays, etc.)

Dimensions:

Dimensions in mm, not to scale

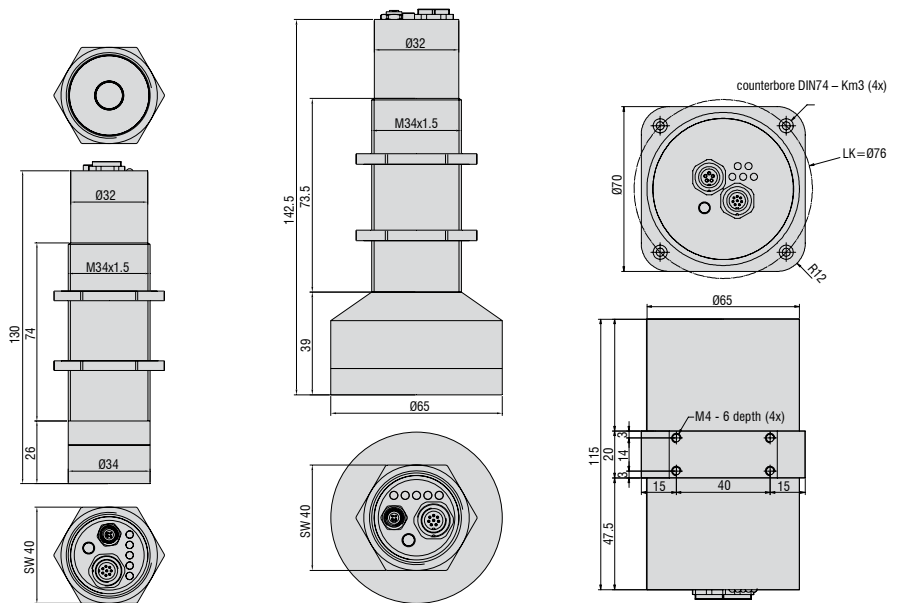

OT-3-HR-30-8/OT-3-HR-30-16
OT-3-HR-50-12.5/OT-3-HR-50-25

OT-3-HR-80-36

OT-3-aHR-200-20

Type	OT-3-HR-30-8	OT-3-HR-30-16	OT-3-HR-50-12.5	OT-3-HR-50-25	OT-3-HR-80-36	OT-3-HR-200-20
Article number	10234079	10234080	10234081	10234082	10234083	10234084
Object distance	typ. 10mm-40mm ideal distance 30mm		typ. 20mm-80mm ideal distance 50mm		typ. 40mm-100mm ideal distance 80mm	typ. 50mm-300mm ideal distance 200mm
Light spot	Ø 4-10mm	Ø 8-20mm	Ø 5-20mm	Ø 10-40mm	Ø 30-40mm	Ø 5-30mm
Light spot diameter	Ø 8mm at 30mm	Ø 16mm at 30mm	Ø 12.5mm at 50mm	Ø 25mm at 50mm	Ø 36mm at 80mm	Ø 20mm at 200mm
Colour difference	$\Delta E \geq 0.5$					$\Delta E \geq 1.5$
Colour spaces	X/Y INT; s/i M (Lab)					
Averaging	more than max. 32768 values					
Size of the colour memory	max. 31 colours in non-volatile EEPROM with parameter sets					
Switching frequency	max. 30kHz (depending on number of colours being taught and the setting for the averaging)					
Reproducibility	In the x,y colour range, 1 digit each with 12-Bit-A/D conversion					
Temperature drift X,Y	< 0.01% /K					
Light source	8x white light LED	8x white light LED	8x white light LED	8x white light LED	12x white light LED	10x white light LED modulated 30kHz
	AC-, DC mode (adjustable or OFF for self-luminous objects, software-switchable)					
Type of illumination	Polarisation filter, focused					
Effect through illumination	great reduction of the shine effect, ideal for highly reflecting surfaces					
Ambient light	to 5000Lux (AC mode)					to 5000Lux
Intermittent light operation	AC: typ. 10kHz bis 40kHz (depending on amplification level AMP1 to AMP8) DC: switchable by PC software					30kHz
Power supply	+24VDC ($\pm 10\%$), inverse polarity protected, overload-proof					
Current consumption	typ. 320mA					
Max. switching current	100mA, short-circuit protected					
TEACH button/inputs	1 button and IN0 for external teaching of the colour references					
Outputs	OUT 0 - OUT 4, digital (0V/+Ub), short-circuit protected, 100mA max. switching current npn-, pnp-capable (bright or dark switching, switchable)					
Switching state display	visualisation by means of 5 yellow LEDs					
Interface	RS232 (USB optional)					
Type of connector	to PLC: 8-pole flange socket (binder series 712) to PC: 4-pole flange socket (binder series 707)					to PLC: 8-pole flange socket (binder series 712) to PC: 5-pole flange socket (binder series 712)
Connection cable	to power/PLC: art. no. 11234091 to PC: art. no. 11234095 (RS232); 11234096 (USB)					to power/PLC: art. no. 11234091 to PC: art. no. 11234092
Receiver	3-colour filter detector (TRUE COLOR detector, colour filter curve as per CIE 1931)					
Software	colorCONTROL S					colorCONTROL C4
Pulse extension	adjustable 0ms-100ms					
Signal amplification	8 stage (AMP1 - AMP8), adjustable					
Housing material	aluminium, black anodised					
Operating temperature	-20°C - +55°C					
Storage temperature	-20°C - +85°C					
Protection class	IP67 (lens), IP64 (electronics)					IP64
EMC test according	DIN EN 60947-5-2					



- Colour sensor for large distances
- 31 colours can be saved
- Coaxial optics for large working distance up to 900mm
- Colour and grey scale evaluation
- PC programmable via RS232

Features:

- Object distance typ. 50mm - 900mm
- Integrated receiver and transmitter optics (coaxial)
- Colour memory: 31 colours via Teach-in and software
- RS232 interface (USB adapter optional)
- Super-bright white light LED
- Colour, contrast and grey-scale detection
- Insensitive to external light up to 5000Lux
- Switchable brightness readjustment
- Switching frequency max. 35kHz
- A variety of evaluation algorithms can be activated e.g. „BEST HIT“ mode
- Switching state display via 5 yellow LEDs
- Temperature compensated ($< 0.01\% / K$)
- Switchable averaging
- Colour control of self-luminous objects

Application examples:

- Colour recognition from long distances up to 900mm
- Correct insertion of product in production machinery
- Inspection of packaging
- Sorting tasks on the basis of colour
- Colour assignment on automobiles
- Detecting drink crates
- Paper, recycling recognition
- Illumination recognition as per colour and intensity

Dimensions:

Dimensions in mm, not to scale

OT-3-LD-200

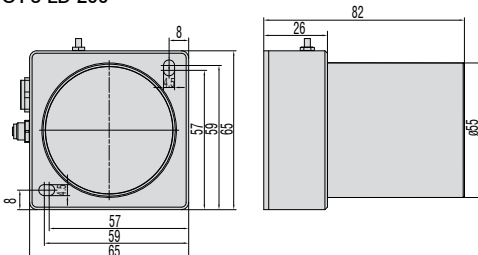

OT-3-LD-500

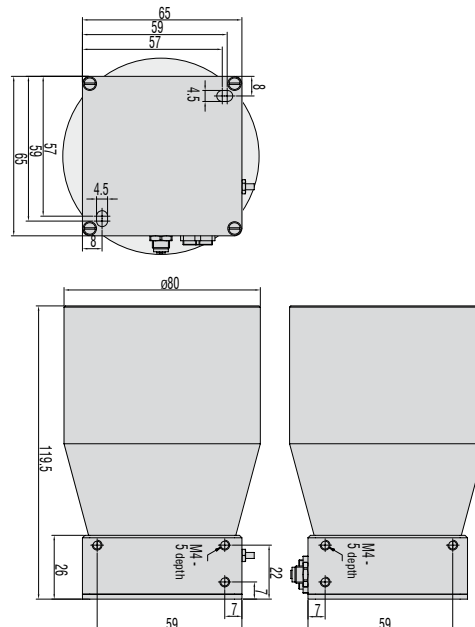

Typ	OT-3-LD-200-6	OT-3-LD-200-12	OT-3-LD-200-26	OT-3-LD-500-23	OT-3-LD-500-50
Article number	10234434	10234437	10234438	10234085	10234086
Object distance	typ. 100 - 700mm ideal distance 200mm	typ. 50 - 500mm ideal distance 200mm	typ. 50 - 500mm ideal distance 200mm	typ. 100 - 900mm ideal distance 500mm	typ. 100 - 900mm ideal distance 500mm
Light spot	Ø 4 - 28mm	Ø 4 - 32mm	Ø 6 - 70mm	Ø 6 - 46mm	Ø 8 - 105mm
Light spot diameter	Ø 6mm at 200mm	Ø 12mm at 200mm	Ø 26mm at 200mm	Ø 25mm at 500mm	Ø 58mm at 500mm
Colour difference	$\Delta E \geq 1$	$\Delta E \geq 1$	$\Delta E \geq 1$	$\Delta E \geq 1,5$	
Colour spaces	X/Y INT; s/i M (Lab)				
Averaging	more than max. 32768 values				
Size of the colour memory	max. 31 colours in non-volatile EEPROM with parameter sets				
Switching frequency	max. 35kHz (depending on number of colours being taught and the setting for the averaging)				
Reproducibility	in the x,y colour range, 1 digit each with 12-Bit-A/D conversion				
Temperature drift X,Y	< 0,0% / K				
Light source	super-bright white light LED; AC-, DC- oder PULSE mode (adjustable or OFF for self-luminous objects, software-switchable) ¹⁾				
Type of illumination	coaxial				
Effect through illumination	large object distance				
Ambient light	to 5000Lux (in AC and PULSE mode)				
Intermittent light operation	AC: typ. to 20kHz (depending on amplification level AMP1 to AMP8) DC: typ. to 35kHz PULSE: typ. to 5kHz switchable by PC software				
Power supply	+24VDC ($\pm 10\%$), inverse polarity protected, overload-proof				
Current consumption	typ. 160mA				
Max. switching current	100mA, short-circuit protected				
TEACH button/inputs	1 button and IN0 for external teaching of the colour references				
Outputs	OUT 0 - OUT 4, digital (0V/+Ub), short-circuit protected, 100mA max. switching current npn-, pnp-capable (bright or dark switching, switchable)				
Switching state display	visualisation by means of 5 yellow LEDs				
Interface	RS232 (optional USB)				
Type of connector	to PLC: 8-pole flange socket (binder series 712) to PC: 4-pole flange socket (binder series 707)				
Connection cable	to power/PLC: art. no. 11234091 / to PC: art. no 11234095 (RS232); 11234096 (USB)				
Receiver	3-colour filter detector (TRUE COLOR detector, colour filter curve as per CIE 1931)				
Software	colorCONTROL S				
Pulse extension	adjustable 0ms-100ms				
Signal amplification	8 steps (AMP1 - AMP8), adjustable				
Housing material	aluminium, black anodised				
Operating temperature	-20°C - +55°C				
Storage temperature	-20°C - +85°C				
Protection class	IP67 (lens), IP64 (electronics)				
EMC test according	DIN EN 60947-5-2				

¹⁾ suitable for illumination testing



- Colour sensor for fluorescent objects
- 31 colours can be saved
- UV illumination to detect luminescent colours
- Colour and grey scale evaluation
- PC programmable via RS232

Features:

- UV-LED ring with black glass cover, 385nm
- Object distance typ. 10mm - 100mm
- Colour memory: 31 colours via Teach-in and software
- RS232 interface (USB adapter optional)
- Recognition of different luminescent colours
- Insensitive to external light up to 5000Lux
- Switchable brightness readjustment
- Switching frequency max. 30kHz
- A variety of evaluation algorithms can be activated, e.g. „BEST HIT“ mode
- Switching state display via 5 yellow LEDs
- Switchable averaging

Application examples:

- Presence of the applied adhesive
- Detection of safeguarding thread
- Turbidity of liquids

Dimensions:

Dimensions in mm, not to scale

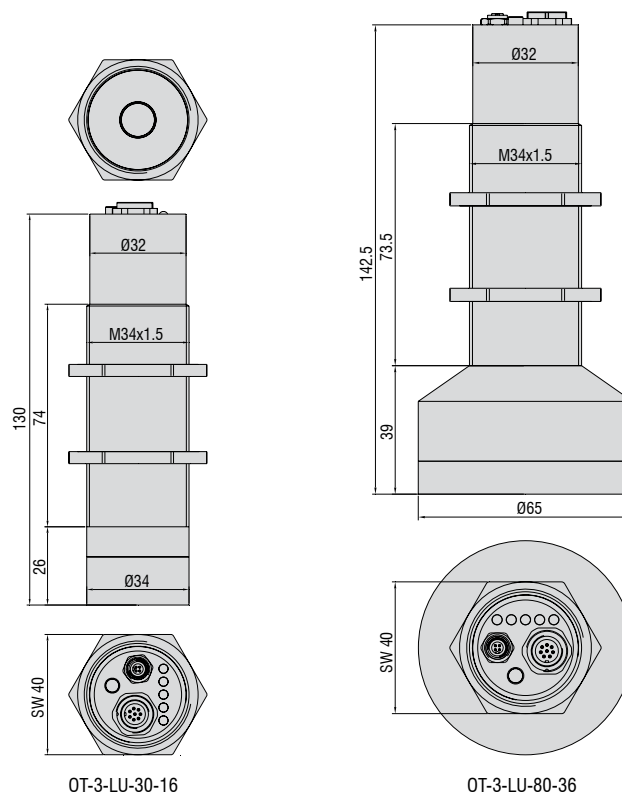

Type	OT-3-LU-30-16	OT-3-LU-80-36
Article number	10234087	10234088
Object distance	typ. 10mm-40mm ideal distance 30mm	typ. 40mm-100mm ideal distance 80mm
Light spot	Ø 8-20mm	Ø 30-40mm
Light spot diameter	Ø 16mm at 30mm	Ø 36mm at 80mm
Colour difference	$\Delta E \geq 0.5$	
Colour spaces	X/Y INT; s/i M (Lab)	
Averaging	more than max. 32768 values	
Size of the colour memory	max. 31 colours in non-volatile EEPROM with parameter sets	
Switching frequency	max. 30kHz (depending on number of colours being taught and the setting for the averaging)	
Reproducibility	in the x,y colour range, 1 digit each with 12-Bit-A/D conversion	
Temperature drift X,Y	< 0.01% /K	
Light source	8x UV-LED, 385nm AC-, DC mode (adjustable or OFF for self-luminous objects, software-switchable)	12x UV-LED, 385nm AC-, DC mode (adjustable or OFF for self-luminous objects, software-switchable)
Type of illumination	UV 385nm, focused	
Effect through illumination	luminescent colours	
Ambient light	to 5000Lux (AC mode)	
Intermittent light operation	AC: typ. 10kHz to 40kHz (depending on amplification level AMP1 to AMP8) DC: switchable by PC software	
Power supply	+24VDC ($\pm 10\%$), inverse polarity protected, overload-proof	
Current consumption	typ. 320mA	
Max. switching current	100mA, short-circuit protected	
TEACH button/inputs	1 button and IN0 for external teaching of the colour references	
Outputs	OUT 0 - OUT 4, digital (0V/+Ub), short-circuit protected, 100mA max. switching current npn-, pnp-capable (bright or dark switching, switchable)	
Switching state display	visualisation by means of 5 yellow LEDs	
Interface	RS232 (optional USB)	
Type of connector	to PLC: 8-pole flange socket (binder series 712) to PC: 4-pole flange socket (binder series 707)	
Connection cable	to power/PLC: art. no. 11234091 / to PC: art. no 11234095 (RS232); 11234096 (USB).	
Receiver	3-colour filter detector (TRUE COLOR detector, colour filter curve as per CIE 1931)	
Software	colorCONTROL S	
Pulse extension	adjustable 0ms-100ms	
Signal amplification	8 stage (AMP1 - AMP8), adjustable	
Housing material	aluminium, black anodised	
Operating temperature	-20°C - +55°C	
Storage temperature	-20°C - +85°C	
Protection class	IP67 (lens), IP64 (electronics)	
EMC test according	DIN EN 60947-5-2	



- Multiple-point colour testing system
- Optionally with up to 20 channels
- Colour testing in HSI and RGB colour space
- Colour differentiation/intensity test

Features:

- Universal connection of fibre optics
- Individual adaptation of the fibre optic configuration
- Each measuring point can be freely configured to colour, intensity and function
- Integration in test sequence
- Good/poor evaluation
- Output of HSI, RGB and XY values via RS232 or USB
- External trigger
- Replaceable fibre optic adapter
- Suitable for POF (2m) and glass fibre optics up to 5m
- Up to 20 testing points using different assembly kits

Anwendungen:

- Self-luminous object inspection
- LED test (binning)
- Indication test
- Display test
- 7 segment display inspection
- Checking up to 20 colours parallel and simultaneously $\leq 1s$
- Frontpanel test
- With external illumination, multiple-point colour testing is possible

Function:

The colour, intensity and light information is fed directly from the measuring object to the MFA via single fibre bundles and evaluated at up to 20 points at the same time. The inspection of inaccessible and/or remote systems is not difficult with the MFA series, because the information is transmitted to the intelligent evaluation system via fibre optics.

The colorCONTROL MFA-5 can be enlarged up to 20 testing points using the module colorCONTROL MFA-5-M. Additionally, one of the assembly kits is required depending on the construction depths (see accessories). For example: 20 inspection tests require: 1x colorCONTROL MFA-5 + 3x colorCONTROL MFA-5-M + 1x assembly kit MFA-20.

Dimensions:

Dimensions in mm, not to scale

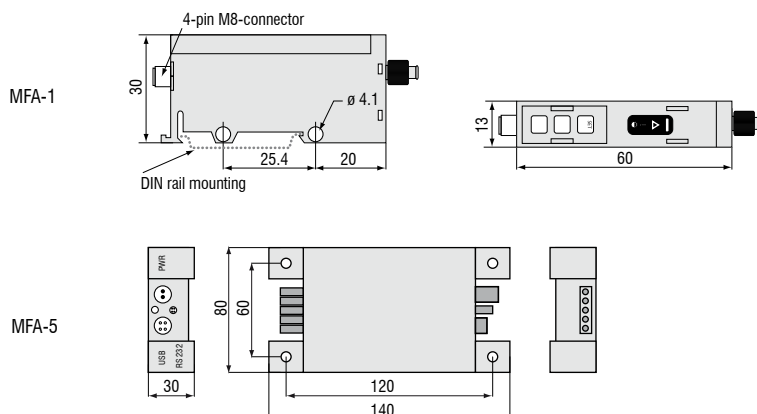

Type	MFA-1	MFA-5	MFA-5-M ¹⁾	MFA-5-P
Article number	11094302	11094050	11094051	11094052
Measuring points	1	5	extension of MFA-5 up to 10/15 or 20	5
Test spectrum	480 - 1000nm		450 - 650nm	
Power supply	10 - 30VDC	24VDC +/- 10% residual ripple	24VDC via MFA-5	5VDC
Current consumption	100mA	80mA-320mA	160-320mA	80mA
Interface	-	RS232, USB, daisy chain	daisy chain	RS232, USB, daisy chain
Inputs	1 external teach input	-	-	-
Outputs	1 switching output npn/pnp	-	-	-
	-	-	-	-
	-	-	-	-
Photo Receiver	1x black and white photodiode		5x TRUE COLOR photochip	
Accuracy	±5%		±4nm	
Resolution	-		9-81 pixels per measuring point	
Data memory	EEPROM	-	-	-
Object distance			typ. 1-5mm	
Fibre optic	incl. POF 1m; max. POF 2m / glass 5m		incl. POF 0.5m; max. POF 2m / glass 5m	
Colour space	-		HSI, RGB, XY + colour temperature in K	
Dynamic range			200lx - 4000lx	
Testing frequency	≤5Hz		≤1Hz (20 measuring points ≤1s)	
Operating temperature	0 to +60°C		0 to +50°C	
Humidity			20% to 80% rel. humidity (non-condensing)	
Protection class	IP 65	IP 50	IP 50	IP 0

¹⁾ Modular extension to 10/15/20 measuring points



- For colorSENSOR
- High-quality fibre optics with polished and ground end-faces
- Fibres for visible, ultraviolet and infrared light
- For wavelengths from 190 – 2500nm

Features:

- Temperature stability from -40°C to $+400^{\circ}\text{C}$ (special bonding)
- Various aperture angles available 68° (NA0.86), 22° (NA0.21), 121° (NA0.87)
- Maximum cable lengths of 30m available; default lengths: 600, 1200, 1800 or 2400mm
- Large selection of sensor mechanisms for different tasks

Standard versions

Micro-Epsilon fibre optics for colour sensors and fibre optic sensors for measurements and testing feature a high build and transmission quality.

Ground and polished end-faces ensure excellent optical integration with adapted sensors. A large selection of sensor mechanisms provides optimum flexibility for a great variety of tasks.

Special versions

Fibre optics with increased vibration protection

Fibre optics can be manufactured to include increased vibration protection for use with high mechanical loads, such as shock, acceleration, and movement. This special treatment minimises friction between fibres and reduces shocks.

Fibre optics with special bonding for high temperatures

Standard bonding is suitable for maximum temperatures of 80°C .

Special adhesives allow for temperatures of up to 250°C , even 400°C . These higher temperature ranges require the use of Type E stainless steel sheathing. Temperatures of up to 600°C can be reached with metallized fibres and with sapphire optics installed.

Customer-specific designs

One of the advantages of Micro-Epsilon fibre optic manufacturing is the production of customer-specific designs for various complex sensor mechanisms.

Technical data			
Single fibre diameter	20, 30, 50, 70µm standard fibre (depending on structure)		
Aperture angle	standard fibres	67° (NA 0.56)	
	special fibres	22° (NA 0.21) 121° (NA 0.87 / wide angle) 22° UV (80/100µm) 22° IR (80/100/150µm)	
Material	optical glass (e.g. for UV / IR / in quartz glass)		
Dielectric strength	50kV/m with PVC protective sheath		
Sensor mechanism – temperature range, fibre bonding	standard	-20°C to + 80°C	
	T250	0°C to + 250°C	
	T400	-40°C to + 400°C	
	T600	0°C to + 600°C	
Permissible temperature range with sheathing that has appropriate fibre bonding	PVC	-20°C to +80°C	(P) (Z)
	metal	+40°C to +180°C	(M)
	metal with special bonding	-40°C to +400°C	(E)
	metal/silicone	-40°C to +180°C	(T)
Fibre transmission	usable for wavelengths from 190-2500nm of different types (we can provide the most suitable solution depending on the requirements) Transmission curves on request!		

Order code for fibre optics

You can see an overview of the Fasop fibre optic range on the following pages.

You can define your own individual fibre optic from the various components using the order key.

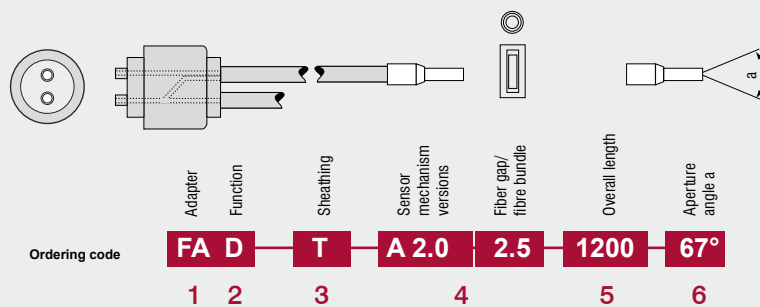

- 1** Adaption to FA-adapter
- 2** Function of the fibre optic (D = transmitted light mode, R = reflex mode)
- 3** Sheathing e.g. silicone-metal sheath (T)
- 4** Sensor mechanism type, e.g. A2.0
Fibre bundle e.g. 2.5mm dia.
- 5** Overall length of e.g. 1200mm (standard length / bearing types)
- 6** Aperture angle of the fibre, e.g. 67°

1 Adapter version

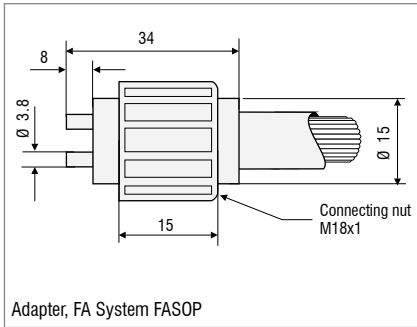

2 Functions

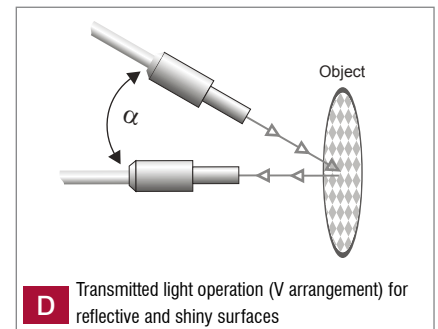
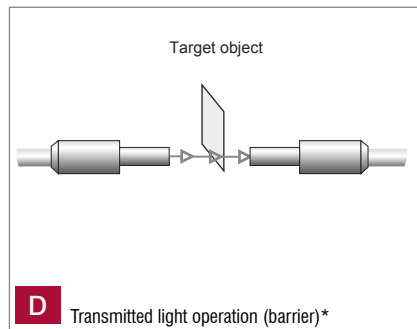
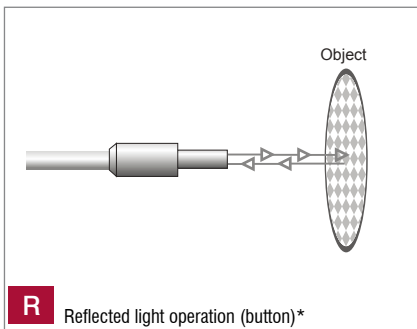

* All functions can also be performed as multiple reflex and transmitted light functions

3 Sheathing

Silicone metal sheath

Metal wire-spiral-reinforced hose with glass fibre braiding and silicone rubber sheathing



Very flexible, highly resistant to bending, tension and torsion; temperature-stable to 180°C, liquid-tight

T

Stainless-steel sheath

Flexible stainless steel wire-spiral-reinforced hose¹⁾



Flexible, protection against mechanical stress, temperature-stable to 400°C

E

Metal sheath

Flexible brass wire-spiral-reinforced hose¹⁾



Flexible, protection against mechanical stress, temperature-stable to 180°C

M

PVC-metal sheath

Flexible brass spiral-reinforced hose coated with PVC sheathing¹⁾

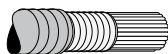

Flexible, protection against mechanical stress, temperature-stable to 80°C

Z

PVC special sheath

Highly flexible plastic hose²⁾



Highly flexible, small sheath diameter, temperature-stable to 80°C

P

¹⁾ Bending radius corresponds to three times the external diameter of the sheath.
²⁾ Bending radius corresponds to twice the external diameter of the sheath.

Details of sheath diameters can be found in Section 4:

Please note: Every version can be supplied with increased vibration protection (VS). See the „Special versions“ section for more information

4 Sensor mechanism variants and fibre bundles

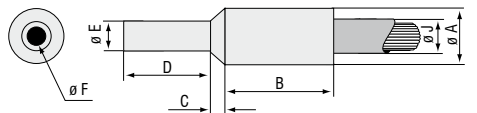

Type	A Ø	B	C	D	E Ø	F Ø	P	ØJ	M	T
A 1.0	4.6	8	2	11	2.5	1.5	4	4		-
A 1.1	6.6	8	2	11	2.5	1.5	-	5		4.4
A 2.0	6.6	10	2	12	4.5	2.5	6	6		5.8
A 3.0	8.5	11	2	15	6	3	7	7		7.5

A Type A ferrule, stainless steel

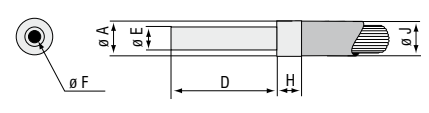

Type	A Ø	D	E Ø	F Ø	H	ØJ	P	Ferrule
B 1.1	2	30	1	0.6	2	2		stainless steel
B 1.2	2	10	1	0.6	2	2		stainless steel
B 2.0	3	10	2	1	2	3		alu
B 3.0	5	12	4	2.5	2	5		alu
B 4.0	8	12	6	3	2	8		alu

B Type B ferrule
(only suitable for PVC sheathing)

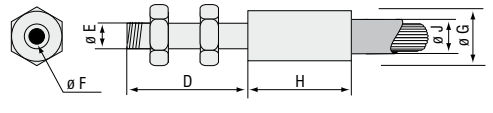

Type	D	E	F Ø	G Ø	H	P	ØJ	M	T
C 1.0	30	M4	1.0	6	13	5	5	5	4.4
C 2.0	30	M6	2.5	8	15	6	6	6	5.8
C 3.0	30	M10	3	11	12	7	7	7	7.5

C Type C ferrule, stainless steel

Standard sensor mechanism, bonding
for -20°C to +80°C
Special designs available (T250, T400, T600)

All details in mm
Tolerances: typ. +/- 0.1mm
Al ferrule, black anodised

Different sizes are possible by arrangement,
please ask our product specialists.
(see also the „Special versions“ section)

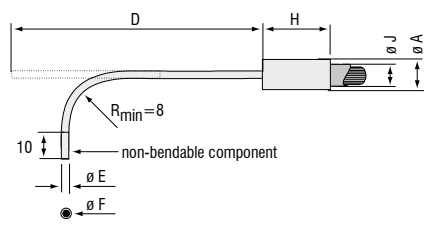

Type	A Ø	D	E Ø	F Ø	H	P	ØJ	M	T
O 1.0	2	100	1	0.6	10	2	-	-	-
O 1.1	7	100	1	0.6	20	-	5	5	4.4
O 2.0	3	100	1.3	1	10	3	-	-	-
O 2.1	7	100	1.3	1	20	-	5	5	4.4

O Type O ferrule, bendable, to an extent

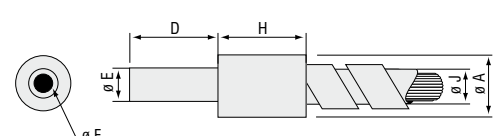

Type	A Ø	D	E Ø	F Ø	H	ØJ	P	Ferrule
M 1.1	6	30	1	0.6	10	5	4.4	stainless steel
M 1.2	6	10	1	0.6	10	5	4.4	stainless steel
M 2.0	6	10	2	1	10	5	4.4	alu
M 3.0	7	12	4	2.5	12	6	5.8	alu
M 4.0	9	12	6	3.5	12	7	7.5	alu
M 5.0	12	16	7	5	16	9	9	alu
M 6.0	13	16	8	6	18	10	11.5	alu
M 8.0	16	20	10	8	20	13	13.5	alu
M 10.0	18	20	12	10	20	15	-	alu

M Type M ferrule

4 Sensor mechanism variants and fibre bundles

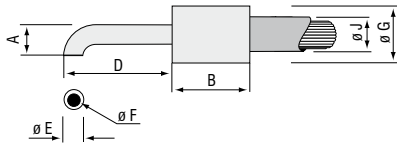

Type	A Ø	B	D	E Ø	F Ø	G Ø	r	P	ØJ M	T
D 1.0	2.5	10	20	1	0.6	3	1.5	2	-	-
D 1.1	2.5	13	20	1	0.6	6	1.5	-	-	4.4
D 2.0	6	13	20	2	1.5	6	4	5	5	4.4
D 3.0	15	17	20	5	2.5	9	10	7	7	6.5

D Type D ferrule, stainless steel
(* D1.0 only suitable for PVC sheathing)

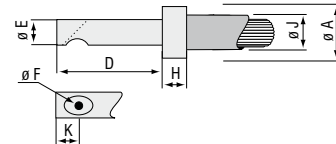

Type	A Ø	D	E Ø	F Ø	H	K	P	ØJ M	T
E 1.0	4	20	3	1.5	1.5	4	4	-	-
E 2.0	5	20	4	2.5	1.5	4	5	5	-
E 2.1	7	20	4	2.5	10	4	-	-	5.8
E 3.0	8	20	6	3	1.5	5	7	7	-

E Type E ferrule, stainless steel
(* E1.0 only suitable for PVC sheathing)

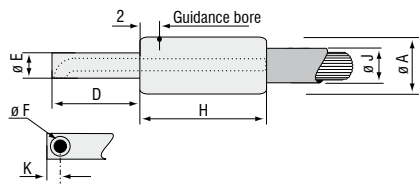

Type	A Ø	D	E Ø	F Ø	H	K	P	ØJ M	T
F 1.0	8	20	6	1.5	9	3	5	5	5.8
F 2.0	10	20	8	2.5	10	4	6	6	6.5
F 3.0	12	20	10	3	10	5	7	7	7.5

F Type F ferrule, stainless steel

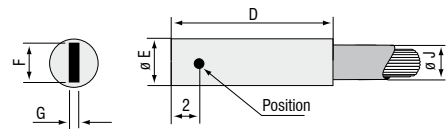

Type	D	E Ø	F	G max.	P	ØJ M	T
R 1.0	25	4	3	0.5	3	-	-
R 1.1	30	7	3	0.5	6	6	5.8
R 2.0	25	7	6	1	6	6	5.8**
R 2.1	30	10	6	1	-	7	7.5

R Type R ferrule, aluminium
* R1.0 only suitable for PVC sheathing
** at 6x1 mm², can be made to a length of 1200

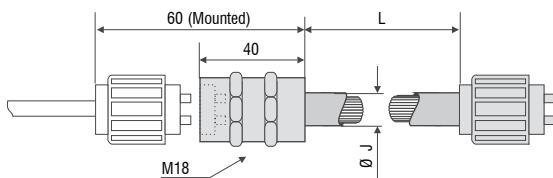

Fibre bundle Ø	P	ØJ M	T	L
(3mm)/ channel	12	13	13.5	variable

LV Type LV ferrule
Fibre optic extension / feed-through

All details in mm

Attention: With angular sensor mechanism versions, a reduction in range can be expected compared to axially emerging versions.

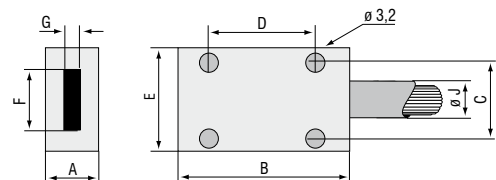

Type	A	B	C	D	E	F	G	ØJ
Q1	12	25	9	15	15	5	0.5	dependent on fibre cross-section
Q2	12	30	14	20	20	10	0.3	
Q3	12	35	24	25	30	18	0.3	
Q4	12	55	34	40	40	28	0.2	
Q5	12	55	44	40	50	38	0.15	
Q6	12	55	54	40	60	48	0.15	
Q7	16	75	64	60	70	58	*	
Q8	16	75	74	60	80	68	*	
Q9	20	90	84	75	90	78	*	
Q10	20	90	94	75	100	88	*	

(F x G 3.5 mm² for CLS and IFA applications with FA adapter)

Q Type Q, aluminium
Also available in stainless steel

5 + 6 Length and aperture angle



Standard lengths are: 600*, 1200*, 1800 and 2400mm.

* Bearing types

Length tolerance type: +/- 4%

5 Cable lengths of up to 30m can be supplied on request!

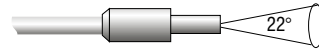

22°

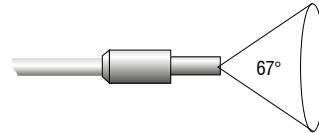

67°

Dependent on the glass fibre material used the following aperture angles are included in the standard range: 22°, 67°, 121°

6

Detection areas, various sensor mechanisms

Fibre bundle ØF mm	Working distance mm	Light spot for 67° fibre approx. Ø mm	Light spot for 22° fibre approx. Ø mm
0.6	5	3	3
	10	5	4
	15	8 ¹⁾	6
	20	12 ¹⁾	8
1	5	3	3
	10	7	5
	15	11	8 ¹⁾
	20	15 ¹⁾	11 ¹⁾
1.5	5	4	3
	10	7	5
	15	11	8
	20	19 ¹⁾	11
2.5	5	5	4
	10	10	8
	15	13	10
	20	19 ¹⁾	13
3	5	8	5
	10	12	7
	15	15	10
	20	18 ¹⁾	13

Typical values were determined using colorSENSOR LT-2-ST

¹⁾ Can be realised only in certain conditions



- Focussing of colour and fibre optic sensors

- Improving the efficiency of the application

- Many possible applications

Features:

- Working distances from 8mm to 200mm
- Scratch-resistant glass lens
- Robust aluminium housing (black anodised)
- Bundling to a small light spot
- Increasing the range
- Minimum colour change when the distance is altered
- High luminous efficiency
- Special designs possible, according to customer requirements
- Colour measurement on small objects at a relatively large distance (KL-3, KL-4)
- Recognising highly absorbent objects (KL-5, KL-14, KL-17)

	Type LWL FASOP	Article number	Object distance (typ.)	Detection range (typ.)*	Dimensions
	KL-3-A2.0 ³⁾	10823012	8mm - 20mm	Ø 1mm - 5mm Ø 1mm at 10mm	L x Ø ap. 60mm x 15mm
	KL-M18-A2.0 ¹⁾	10823020	20mm - 50mm	Ø 3mm - 10mm Ø 3mm at 20mm	L x Ø ap. 51mm x M18 x 1
	KL-M18-XL-A2.0 ¹⁾	10824358	Pos1 50 - 120mm Pos2 10 - 180mm Pos3 10 - 160mm	Pos1 Ø 4-7mm Ø 4mm at 80mm Pos2 Ø 7-11mm Ø 7mm at 110mm Pos3 Ø 7-11mm Ø 7mm at 120mm	L x Ø ap. 90mm x M18x1 (L=50mm)
	KL-M34-A2.0 ¹⁾	10823278	100mm - 180mm	Ø 15mm - 18mm Ø 15mm at 100mm	L x Ø ap. 85mm x M34 x 1,5
	KL-M34/62-A2.0 ¹⁾	10824196	80mm - 200mm	Ø 3mm - 5mm Ø 3mm at 120mm	L x Ø ap. 170mm x 62mm
	KL-4-A1.1 ¹⁾	10823262	8mm - 20mm	Ø 0,6mm - 3mm Ø 0,6mm at 10mm	L x Ø ap. 60mm x 15mm
	KL-M18-A1.1 ¹⁾	10824140	10mm - 50mm	Ø 2mm - 7mm Ø 2mm at 10mm	L x Ø ap. 51mm x M18 x 1
	KL-D-40-A2.0 ²⁾	10824143	15mm - 25mm	Ø 3mm - 6mm Ø 3mm at 15mm	L x B x H ap. 43.4 x 49.5 x 12mm
	KL-D-28-A2.0 ²⁾	10824197	20mm - 30mm	Ø 5mm - 8mm Ø 5mm at 20mm	L x B x H ap. 31.7 x 40.5 x 15mm
	KL-D-20-A2.0 ²⁾	10823021	10mm - 50mm	Ø 4mm - 10mm Ø 4mm at 10mm	L x B x H ap. 21.4 x 33 x 12mm
	KL-D-17-A2.0 ²⁾	10823220	30mm - 80mm	Ø 8mm - 25mm Ø 8mm at 30mm	L x B x H ap. 36.5 x 25.5 x 15mm
	KL-D-14-A2.0 ²⁾	10823022	60mm - 120mm	Ø 10mm - 20mm Ø 10mm at 60mm	L x B x H ap. 37 x 50 x 20mm
	KL-D-6-A2.0 ²⁾	10823409	100mm - 200mm	Ø 15mm - 30mm Ø 15mm at 100mm	L x B x H ap. 31.1 x 45.1 x 20mm
	KL-5-R1.1 ¹⁾	10824198	8mm - 20mm	Ø 2mm x 0,3mm to 15mm x 3mm 2x0,3mm at 10mm	L x Ø ap. 60mm x 15mm
	KL-8-R2.1 ¹⁾	10823920	8mm - 20mm	Ø 4mm x 0,7mm to 30mm x 5mm 4x0,7mm at 10mm	L x Ø ap. 60mm x 15mm

* The smallest figure in the table relates to the smallest typical optical diameter that is generated.
This corresponds to roughly the smallest detection area for colour or fibre optic sensors.

¹⁾ Reflex fibre optic (FAR)

²⁾ Transmitted light mode fibre optic cables (FAD)

³⁾ Can be realised in conjunction with FAR-X-A2.0-0.6-XXXX-67° reflex mode fibre optical cable (FAR) measurement spot of approx. 0.2mm

colorSENSOR accessories		
Art. no.	description	suitable for:
11234089	CAB-M23-19P-co-fm-straight; 2m-PUR; open ends	colorSENSOR WLCS M-41 (power and PLC)
11234097	CAB-M23-19P-co-fm-straight; 5m-PUR; open ends	colorSENSOR WLCS M-41 (power and PLC)
11234090	CAB-M9-3P-co-straight; 2m-PUR; RS232	colorSENSOR WLCS M-41 (RS232)
11234098	CAB-M9-3P-co-straight; 5m-PUR; RS232	colorSENSOR WLCS M-41 (RS232)
11234091	CAB-M9-8P-co-straight; 2m-PUR; open ends	colorSENSOR LT and OT series (power and PLC)
11234099	CAB-M9-8P-co-straight; 5m-PUR; open ends	colorSENSOR LT and OT series (power and PLC)
11234092	CAB-M9-5P-co-straight; 2m-PUR; RS232	colorSENSOR OT-3-XX-200 (RS232)
11234100	CAB-M9-5P-co-straight; 5m-PUR; RS232	colorSENSOR OT-3-XX-200 (RS232)
11234093	CAB-M9-4P-co-straight; 2m-PVC; RS232	colorSENSOR LT-1-ST; LT-2-XX (RS232)
11234101	CAB-M9-4P-co-straight; 5m-PVC; RS232	colorSENSOR LT-1-ST; LT-2-XX (RS232)
11234094	CAB-M9-4P-co-straight; 2m-PVC; USB	colorSENSOR LT-2-XX (USB)
11234102	CAB-M9-4P-co-straight; 5m-PVC; USB	colorSENSOR LT-2-XX (USB)
11234095	CAB-M5-4P-co-straight; 2m-PUR; RS232	colorSENSOR LT-1-LC-20; LT-3; OT-3 series (RS232)
11234103	CAB-M5-4P-co-straight; 5m-PUR; RS232	colorSENSOR LT-1-LC-20; LT-3; OT-3 series (RS232)
11234096	CAB-M5-4P-co-straight; 2m-PVC; USB	incl. RS232 to USB adapter suitable for: colorSENSOR LT-1-LC-20; LT-3; OT-3 series (USB)
11234104	CAB-M5-4P-co-straight; 5m-PVC; USB	incl. RS232 to USB adapter suitable for: colorSENSOR LT-1-LC-20; LT-3; OT-3 series (USB)
11234368	CAB-M5-4P-co-straight; 2m-PVC; RJ45-co-fm-Eth	incl. RS232 to Ethernet adapter suitable for: colorSensor LT-1-LC-20; LT-3; OT-3 series (Ethernet)
11234274	reflectance standard 1.25" Fluorilon	colorSENSOR and colorCONTROL
11233482	white reference modul	colorSENSOR LT-2-DU
2420065	PS2030 power supply 24V/24W/ 1A; 2m-PVC; terminal-2P-co-fm-straight	Power supply of all sensors with 24 V DC

colorCONTROL MFA accessories		
Art. no.	description	suitable for:
10814105	POF-2.2mm plastic fibre optic cable	colorCONTROL MFA
11251112	thread fitting; LWL; M4	POF-2.2
11251113	lens optic 6mm	thread fitting; LWL; M4
11253931	thread fitting; 3mm lens; LWL; M4	POF-2.2
11254108	thread fitting; 90° optics; LWL; M5	POF-2.2
11253959	reducer sleeve 2.2/1mm POF; 2 pcs.	colorCONTROL MFA for use of POF-1mm
10813842	POF-1mm fibre optic cable	colorCONTROL MFA in connection with the reducer sleeve 2.2/1mm POF
11253906	guide sleeve 1mm	POF-1mm
10824431	guide sleeve 1 mm x 50 mm	POF-1mm
11234305	CAB-M8-4P-co-fm-straight; 2m-PUR; open ends	colorCONTROL MFA-1 (power and PLC)
11234306	CAB-M8-4P-co-fm-straight; 5m-PUR; open ends	colorCONTROL MFA-1 (power and PLC)
11294205	CAB-M9-2P-co-fm-straight; 2m-PUR; open ends	colorCONTROL MFA-5 (power)
11294206	CAB-M9-2P-co-fm-straight; 5m-PUR; open ends	colorCONTROL MFA-5 (power)
11234094	CAB-M9-4P-co-straight; 2m-PVC; USB	colorCONTROL MFA-5 (USB)
11234102	CAB-M9-4P-co-straight; 5m-PVC; USB	colorCONTROL MFA-5 (USB)
11234095	CAB-M5-4P-co-straight; 2m-PUR; RS232	colorCONTROL MFA-5 (RS232)
11234103	CAB-M5-4P-co-straight; 5m-PUR; RS232	colorCONTROL MFA-5 (RS232)
11294243	assembly kit MFA-10	colorCONTROL MFA-5 + MFA-5-M
11294244	assembly kit MFA-15	colorCONTROL MFA-5 + 2 x MFA-5-M
11294245	assembly kit MFA-20	colorCONTROL MFA-5 + 3 x MFA-5-M
11294203	CAB-socket board-6P-co-fm-straight; 2m-PVC; 2P-open ends	colorCONTROL MFA-5-P (power)
11294054	CAB-socket board-6P-co-fm-straight; 1m-PVC; USB	colorCONTROL MFA-5-P (USB and power)
11294204	CAB-socket board-4P-co-fm-straight; 2.5m-PVC; RS232	colorCONTROL MFA-5-P (RS232)

Pin assignment

CAB-M23-19P-co-fm-straight; Xm-PUR; open ends
(Art. no.: 11234089; 11234097)

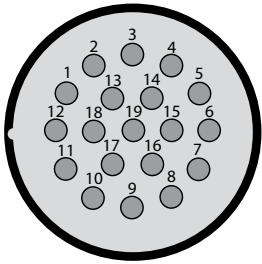

Pin	Colour	WLCS-M-41
1	green	IN TF
2	grey	OUT Int. OK
3	pink	n.c.
4	red	OUT 4
5	white	OUT 2
6	blue	GND (0V)
7	violet	n.c.
8	grey/pink	n.c.
9	red/blue	IN HOLD
10	white/green	IN 1
11	brown/green	IN 2
12	yellow	PE
13	white/yellow	Common
14	-	-
15	black	OUT 1
16	yellow/brown	OUT 3
17	white/grey	IN 3
18	grey/brown	IN 4
19	brown	+24V DC (±10%)

CAB-M9-8P-co-straight; Xm-PUR; open ends
(Art. no.: 11234091; 11234098)
Connection cable to power/PLC or digital I/O
(max. length. 10m, sheath PUR)

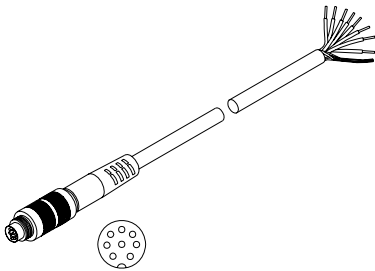

Pin	Colour	LT-1- LC-10 / ST	SB1 LT-2- ST/DU	SB2 LT-2- ST/DU	LT-1-LC-20 LT-3-XX/OT-3-XX
1	white	OUT 0	OUT 0 / OUT A 0	OUT 1	GND (0V)
2	brown	OUT 1	OUT 1 / OUT A 1	OUT 2	+24V DC (±10%)
3	green	IN 1	IN 1	OUT 3	IN 0
4	yellow	IN 0	IN 0	OUT 4	OUT 0
5	grey	n.c. / OUT 4	CLK (OUT K)	OUT 5	OUT 1
6	pink	OUT 3	OUT 2 / OUT A 2	OUT 6	OUT 2
7	blue	GND (0V)	GND (0V)	OUT 7	OUT 3
8	red	+24V DC (±10%)	+24V DC (±10%)	OUT 0	OUT 4

CAB-M8-4P-co-fm-straight; Xm-PUR; open ends
(Art. no.: 11234305; 11234306)
Connection cable to power/PLC
(max. length 5m, sheath PUR)

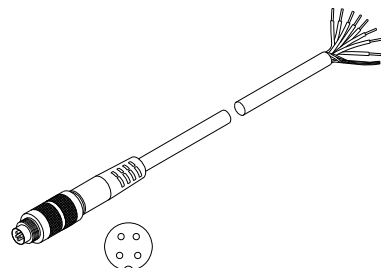

Pin	Colour	MFA-1
1	brown	+ 24V DC
2	white	Extern Teach
3	blue	GND
4	black	NPN/PNP

CAB-M9-2P-co-fm-straight; Xm-PUR; open ends
(Art. no.: 11294205; 11294206)
Connection cable to power
(max. length. 10m, sheath PUR)

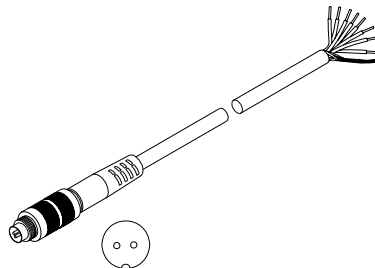

Pin	Colour	MFA-5
1	white	+24V DC
2	brown	GND

High performance sensors made by Micro-Epsilon



Sensors and systems for displacement and position



Sensors and measurement devices for non-contact temperature measurement



2D/3D profile sensors (laser scanner)



Optical micrometers, fibre optic sensors and fibre optics



Colour recognition sensors, LED analyzers and colour online spectrometer



Measurement and inspection systems