



Inspection systems for the metal industry



References (extract)



AMAG
AUSTRIA METALL



DANIELI AUTOMATION



voestalpine

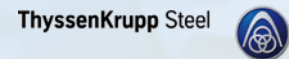

ThyssenKrupp Steel



Constellium



ArcelorMittal



ANDRITZ



MKM
WR LEBEN KUPFER



ZAPP



SPIG



Inter Metal



BÖHLER
EDELSTAHL



NEUMAN
ALUMINIUM



BieleGroup
SMART INDUSTRIAL AUTOMATION



umicore

Innovative laser line measurement

**Innovative laser line**

Non-contact thickness measurement with 1280 discrete measuring points

**Lateral micrometer resolution**

Measuring close to the edges of narrow strips combined with a large measuring range

**Highly dynamic measurement**

128,000 measuring points/sec provide high precision even for structured material such as button plate and checker plate

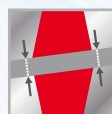
**Recognition and compensation of strip tilting**

Particularly suitable for cut-to-length shears

**No alloy compensation required**

Real geometric, material-independent thickness measurement

**Cost-effective service-lifecycle-management**

Innovative measurement technology without isotopes or X-rays and thus low consequential costs

Overview

Measured features

- Thickness
- Centre thickness
- Edge drop
- Thickness profile
- Wedge and crown bow
- Width



Metal thickness measurement for non-critical ambient conditions
thicknessCONTROL MTS 7202.T/8202.T
 Page 6-7



O-frame systems for profile thickness measurement
thicknessCONTROL MTS 8201.LLT
 Page 12-13



Powerful C-frame for harsh environments
thicknessCONTROL MTS 8202.LLT
 Page 8-9

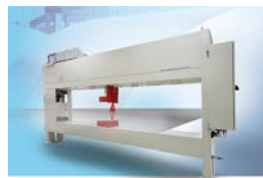

Special systems for special applications
thicknessCONTROL MTS 9201.LLT
 Page 14



C-frame thickness measurement systems for large widths
thicknessCONTROL MTS 8202.LLT-CFK
 Page 10-11



Dynamic width measurement with discrete laser line technology
thicknessCONTROL MWS 8201.LLT
 Page 16-17

More Precision

Fields of application

- Hot rolling mills
- Cold rolling mills
- Processing plants
- Service centres

C-frame measurement on checker plate

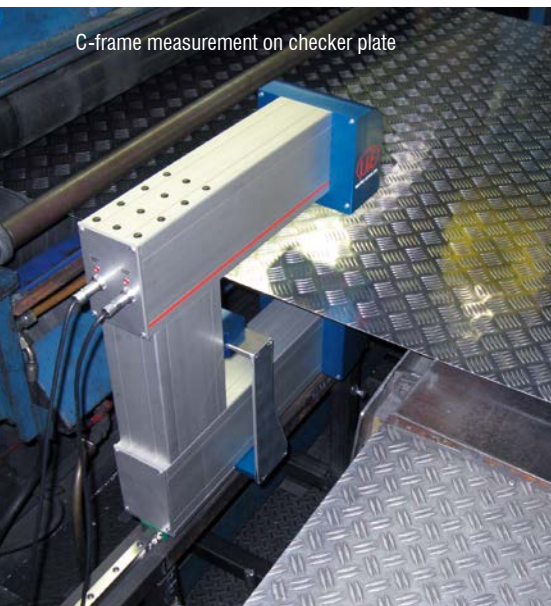

Operating principle of thickness measurement

The principle of dimensional, geometric thickness measurement is based on one optical distance sensor on each side of the material. The distance (=operating range) of both sensors is determined in a calibration process based on a certified measurement standard of which the thickness is added to the sum of the sensor signals in order to determine the current operating range. A 2D sensor not only processes one measuring point.

In the calibration process described above, the coordinate systems of the sensors installed in the upper and lower boom are synchronised. For thickness measurement during production, the difference between the sum of the distance signals and the value of the operating range is determined. The systems are mechanically designed in C-frame or O-frame shape. Both lasers must be projected congruently onto the top side and the rear side of the material in order to achieve an accurate thickness measurement. The sensors are factory-calibrated using an optoelectronic tool and a patented procedure, i.e. the linearity deviation is determined across the entire working range and a correcting function is calculated.

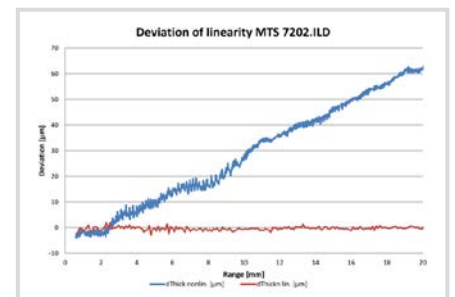

Linearity deviation (accuracy) before and after factory calibration

"Discrete laser line" innovation

When talking about optical thickness measurement, conventional laser point sensors, line triangulation sensors and laser line sensors (=profile sensors/laser scanners) have to be distinguished. With the line triangulation sensor (optoNCDT LL), the oval point-shaped laser beam is widened using a special cylindrical lens and projected onto the target as a line. The light spot is absorbed by a receiving array and evaluated. The average of the line is determined using algorithms in order to eliminate any interference. By using special lenses, a laser beam is enlarged to form a static laser line and is projected onto the target surface. A high quality optical system projects the diffusely reflected light of this laser line onto a highly sensitive sensor matrix which detects during one measurement, depending on the sensor, a profile with 640 or 1280 measuring points. From this matrix image, the integrated controller calculates the distance information (z-axis) and the position alongside the laser line (x-axis) in a two-dimensional coordinate system.

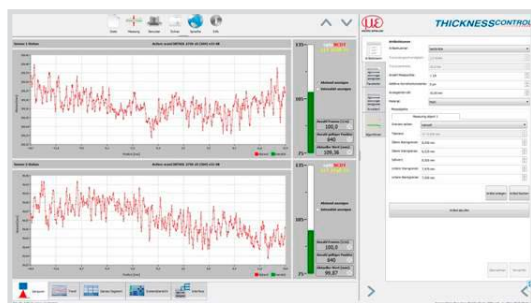

Point cloud diagrams of two laser line sensors

Resolution/Measuring range

Unlike point triangulation whereby the resolution is the smallest measurable thickness change, laser line triangulation is much more complex. Here, the resolution is not determined by evaluating one single point but several points or rather an entire profile is taken into account and a reference line is fitted into the point cloud (best-fit-line).

Therefore, the resolution is the smallest measurable thickness change between two corresponding reference lines and is consequently higher compared with the point triangulation method using the same optical system, i.e. the same measuring range size. With this effect, thicknessCONTROL MTS 820X.LLT provides a large measuring range at extremely high resolution which is particularly beneficial in slitting line applications.

Robust in difficult, industrial environments

Due to their high data rates, laser line sensors have proven to be very stable in harsh environments. In situations where there is a loss of 50% of the measuring points, e.g. due to steam, residual contamination with mill emulsion or reflections on shiny surfaces, the reference line of the usable point cloud still generates very stable measurement values and is thus superior to laser point technology.

Compensating for strip movement

Compared to laser point sensors, laser line triangulation measurement offers improved accuracy and stability. Tilt angles, warping and deformation of the material is recognised using profile sensors and is considered in the measurement results. This enables thicknessCONTROL MTS 820X.LLT to provide high quality thickness measurements with accuracies in the micrometer range, even when the metal sheet to be measured is several mm thick and tilted.

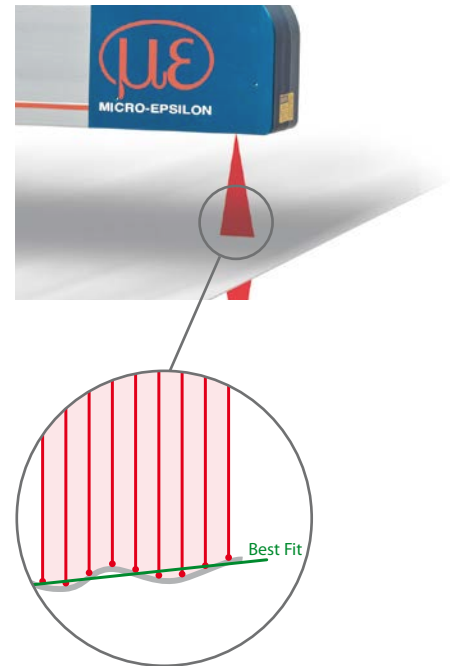

Calculation of the measured value using a reference line

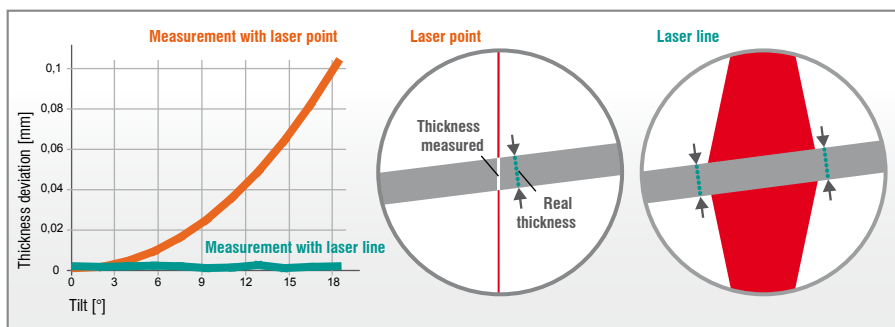

Thickness deviation with tilted strip using laser point or discrete laser line

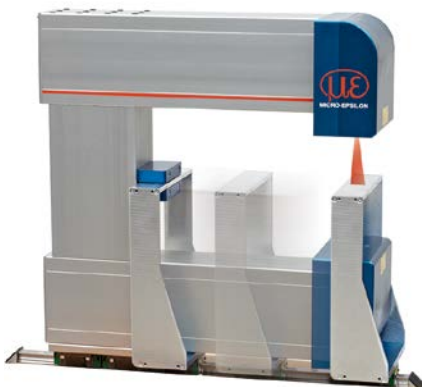

Fully automatic calibration enables long-term measurement stability

Automatic calibration & temperature compensation

The system is equipped with in-situ calibration in order to compensate e.g. for the effects of temperature fluctuations. Depending on the respective application, with this calibration either the reference/calibration piece or the C-frame can be positioned. Furthermore, the correct functioning of the system can be cyclically proven at any time. The analysis software enables easy, fast verification of the measurement system's capability, which can be automated depending on the application.

thicknessCONTROL MTS 7202.T / 8202.T

Metal thickness measurement for non-critical ambient conditions



The thicknessCONTROL MTS 7202.T measurement system is beneficial in simple applications due to its excellent price/performance ratio, its C-frame design and is available in two performance classes. Both operate using optoNCDT LL line triangulation sensors where the precision to range ratio is optimised. This means that the lower sensor has a smaller range as the material thickness increases only in the upper direction.

The integrated controller of the thicknessCONTROL MTS 7202.T system calculates and visualises the measured values. The display is equipped with multi-colour background lighting and changes colour if limit values are exceeded. All controller functions selectable by the user can be displayed and saved using a web browser without having to install additional software. thicknessCONTROL MTS 7202.T is

installed on a linear axis, which enables semi-automatic calibration and manual adjustment of the measuring position.

For fully automatic calibration and positioning on three adjustable positions, the linear axis can be enlarged using a DC motor.

Higher precision and more functionality

The thicknessCONTROL 8202.T variant differs from the thicknessCONTROL MTS 7202.T entry level version due to its higher precision sensors. Furthermore, it includes an IPC with a comprehensive software package for analysing the measured data. thicknessCONTROL 8202.T can be retrofitted with two different drive variants. The DC motor version enables movement to any position for a fixed track measurement, a cross-sectional measurement can be achieved using a position-controlled servo motor.

Special features:

- Simple mounting
- IPC not required for MTS 7202
- Modular extension
- Access to controller via Internet browser



optoNCDT LL laser line technology

The thicknessCONTROL MTS 7202.T/8202.T C-frame is equipped with optoNCDT LL laser line technology. Due to the filter effect on interference from reflecting surfaces, these systems are ideally suited to applications in the metal processing industry.



Controller for thickness measurement



Thickness measurement in a forming line

thicknessCONTROL MTS 7202.T

Description	-2/250	-10/250	-20/250	-40/250	-2/500	-10/500	-20/500	-40/500
Article no.	4350127.11	4350127.12	4350127.13	4350127.14	4350127.15	4350127.16	4350127.17	4350127.18
Laser class	2M							
Measuring width	250mm				500mm			
Operating range	30mm	44mm	70mm	235mm	30mm	44mm	70mm	235mm
Measuring range	2mm	10mm	20mm	40mm	2mm	10mm	20mm	40mm
Start of measuring range	349mm	349mm	355mm	365mm	349mm	349mm	355mm	365mm
Sensor ranges ¹⁾	2mm/2mm	10mm/2mm	20mm/10mm	40mm/20mm	2mm/2mm	10mm/2mm	20mm/10mm	40mm/20mm
Accuracy	±4µm	±10µm	±24µm	±48µm	±4µm	±10µm	±24µm	±48µm
Resolution	0.2µm	0.6µm	2µm	5.5µm	0.2µm	0.6µm	2µm	5.5µm
Protection class ²⁾	IP54							
Ambient temperature ³⁾	min. +15°C max. +40°C							

thicknessCONTROL MTS 8202.T

Description	-2/250	-10/250	-20/250	-50/250	-2/500	-10/500	-20/500	-50/500
Article no.	4350127.01	4350127.02	4350127.03	4350127.04	4350127.05	4350127.06	4350127.07	4350127.08
Laser class	2M							
Measuring width	250mm				500mm			
Operating range	30mm	44mm	70mm	115mm	30mm	44mm	70mm	115mm
Measuring range	2mm	10mm	20mm	50mm	2mm	10mm	20mm	50mm
Start of measuring range	349mm	349mm	355mm	365mm	349mm	349mm	355mm	365mm
Sensor ranges ¹⁾	2mm/2mm	10mm/2mm	20mm/10mm	50mm/20mm	2mm/2mm	10mm/2mm	20mm/10mm	50mm/20mm
Accuracy	±1.2µm	±2.6µm	±6µm	±14µm	±1.2µm	±2.6µm	±6µm	±14µm
Resolution	0.06µm	0.18µm	0.45µm	1.1µm	0.06µm	0.18µm	0.45µm	1.1µm
Weight	from 80kg incl. packing							
Protection class ²⁾	IP54							
Ambient temperature ³⁾	min. +15°C max. +40°C							

- ¹⁾ upper sensor/lower sensor
²⁾ without additional measures
³⁾ without additional cooling

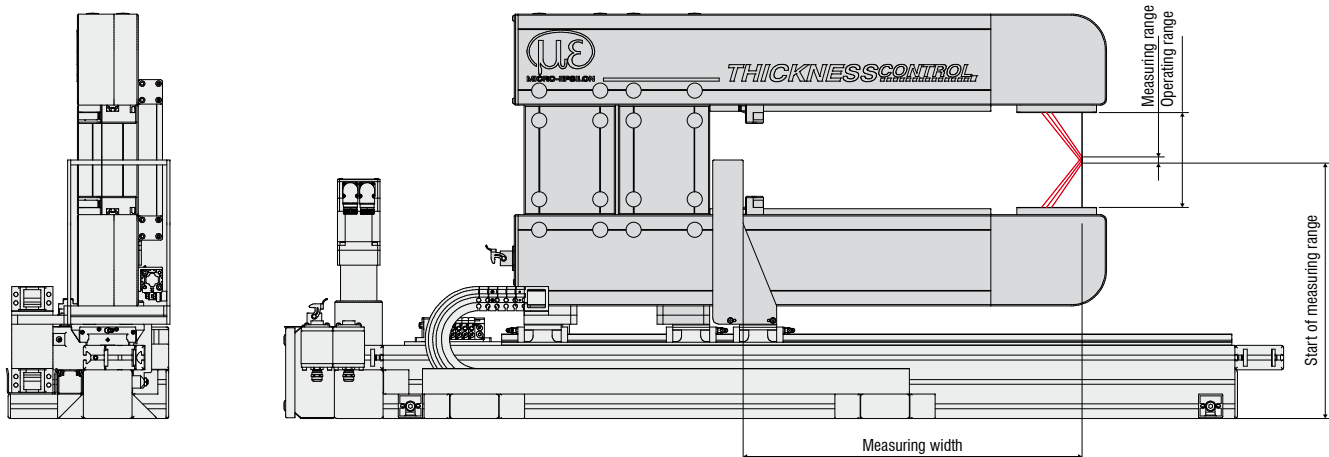

Example illustrating the dimensions

thicknessCONTROL MTS 8202.LLT

Powerful C-frame for harsh environments



The C-frame systems of the thicknessCONTROL MTS 8202.LLT series are equipped with discrete laser line technology. They are suitable for harsh environments and complex (highly reflective) surfaces. The redundancy of the high data rate provides reliable measurements, even when interferences due to steam, emulsion and high gloss surfaces are present.

The control and analysis software of thicknessCONTROL MTS 8202.LLT is multi-touch capable and provides comprehensive visualisation possibilities which can be easily operated by swiping. The user can choose between different working modes. Furthermore, a fully automatic gauge capability management is integrated.

Two C-frames can be easily operated via a computer. thicknessCONTROL can be equipped with a motion controlled servo drive to automatically position the C-frame or to perform cross profile gauging.

Measurement of profile characteristics

The high information density of the discrete laser line can be used to achieve improved robustness of the system and measurement of profile information. This technology is currently the only system that can accurately measure the internal and total thickness of checker or button plate during production. Furthermore, the high lateral resolution enables high precision views of the edge thickness.

Special features:

- Large choice of different measuring ranges to optimise for any application
- Proven protection and cleaning concepts for harsh ambient conditions
- Control and evaluation of two C-frames using an IPC

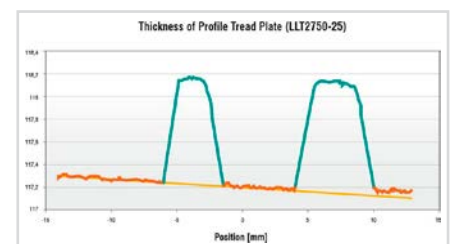

Profile of the top and bottom side of button plate

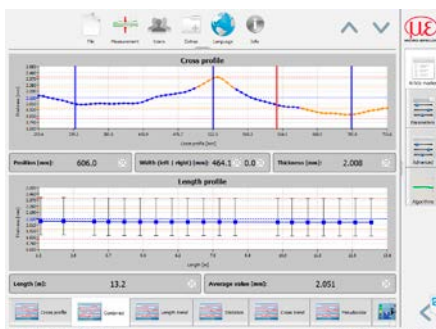

Screenshot combining cross-sectional and longitudinal trend



Thickness measurement in a grinding line

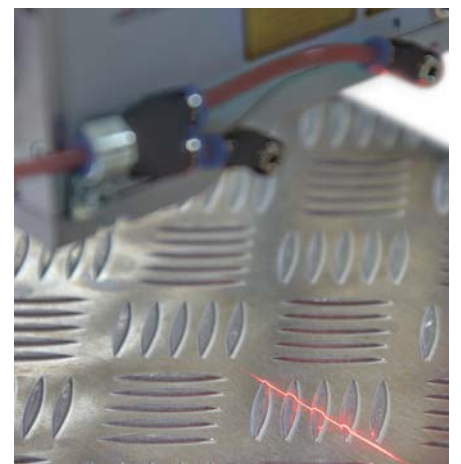

Discrete laser line on button plate

thicknessCONTROL MTS 8202.LLT

Description	-25/250	-50/250	-100/250	-25/500	-50/500	-100/500	-25/800	-50/800	-100/800
Article no.	4350127.21	4350127.22	4350127.29	4350127.23	4350127.24	4350127.70	4350127.71	4350127.72	4350127.73
Laser class	2M								
Measuring width	250mm			500mm			800mm		
Operating range	190mm	400mm	880mm	190mm	400mm	880mm	190mm	400mm	880mm
Measuring range	40mm	100mm	300mm	40mm	100mm	300mm	40mm	100mm	300mm
Start of measuring range	440mm	515mm	665mm	440mm	515mm	665mm	440mm	515mm	665mm
Resolution	$\pm 0.5\mu\text{m}$	$\pm 1\mu\text{m}$	$\pm 4\mu\text{m}$	$\pm 0.5\mu\text{m}$	$\pm 1\mu\text{m}$	$\pm 4\mu\text{m}$	$\pm 0.5\mu\text{m}$	$\pm 1\mu\text{m}$	$\pm 4\mu\text{m}$
Repeatability ¹⁾	$\pm 0.25\mu\text{m}$	$\pm 0.4\mu\text{m}$	$\pm 2\mu\text{m}$	$\pm 0.25\mu\text{m}$	$\pm 0.4\mu\text{m}$	$\pm 2\mu\text{m}$	$\pm 0.25\mu\text{m}$	$\pm 0.4\mu\text{m}$	$\pm 2\mu\text{m}$
Absolute accuracy	$\pm 5\mu\text{m}$	$\pm 10\mu\text{m}$	$\pm 40\mu\text{m}$	$\pm 5\mu\text{m}$	$\pm 10\mu\text{m}$	$\pm 40\mu\text{m}$	$\pm 5\mu\text{m}$	$\pm 10\mu\text{m}$	$\pm 40\mu\text{m}$
Dimensions in mm (W ²⁾ x D x H)	1635x284x735	1635x284x954	1635x287x1425	1885x284x735	1885x284x954	1885x287x1425	2185x284x735	2185x284x954	2185x287x1425
Weight	from 80 kg incl. packing								
Protection class ³⁾	IP54								
Ambient temperature ⁴⁾	min. +15°C max. +40°C								

¹⁾ Standard deviation with 50 measurements

²⁾ Width with linear axis (minimum stroke + drive)

³⁾ without additional measures

⁴⁾ without additional cooling

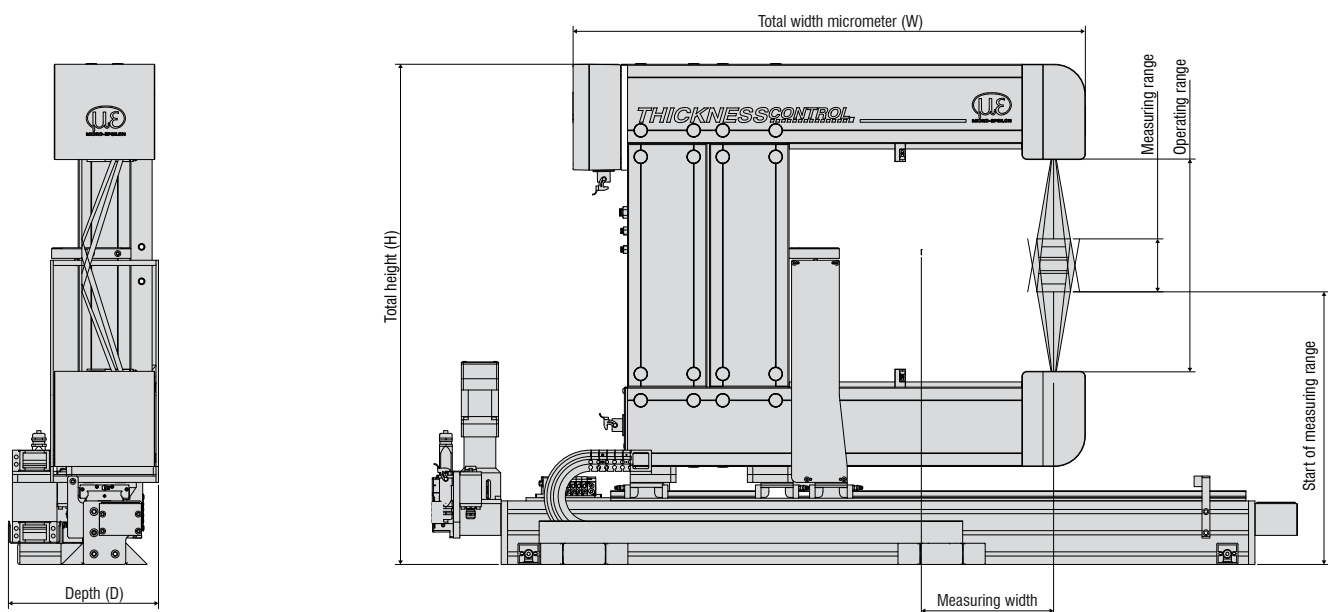

Example illustrating the dimensions

thicknessCONTROL MTS 8202.LLT-CFK

C-frame systems for profile thickness measurement



thicknessCONTROL MTS 8202.LLT-CFK relies on CFRP lightweight material (carbon fibre-reinforced plastic). This low weight protects moving parts of the traversing mechanics and reduces wear, which ensures a long service life. The stiffness of the material prevents vibrations of the upper boom, which would otherwise influence the measurement accuracy of the system.

Because of the measuring principle alone, the discrete laser line is ideally suited to measurement tasks in harsh environments due to the redundancy created by fitting a reference line into the point cloud.

To further increase robustness, all thicknessCONTROL MTS systems can be equipped with special appliances that clean or protect, depending on the kind of appliance, the calibration standard and the optical system of the sensors.

Four different versions are available, which can be selected to suit the respective application. The signal quality is continuously controlled to ensure correct measurements. The product range is completed by a full housing in which the C-frames can be moved for protection purposes when measurements are not being carried out.

Special features:

- Large measuring width with low weight
- Fast data coupling (<10 ms) for rolling mill control system
- Temperature monitoring to prevent sensor overheating (C-frame is automatically moved into parking position)

Precise multi-sensor technology

Depending on the respective model, up to three sensors in the thicknessCONTROL MTS 8202 machines monitor the edge of the metal strip. These control the position of the C-frame with respect to the strip edge and the fixed track using an "edge pursuit" mode or can trigger an "escape run" if the target material could collide with the C-frame.



Optical sensors for edge pursuit

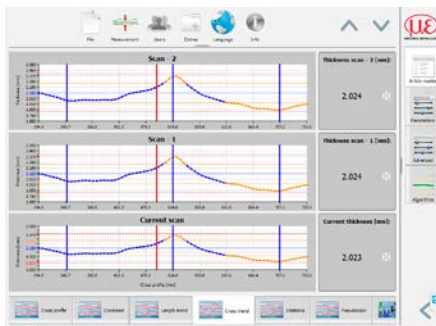

Screenshot cross-section trend

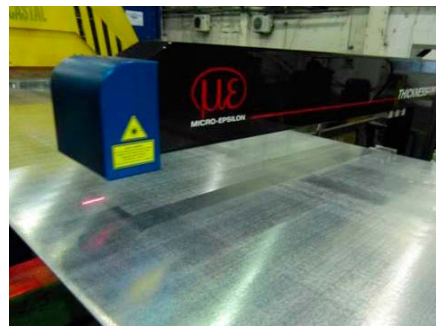

Thickness measurement in a casting line



Thickness measurement in a milling line

thicknessCONTROL MTS 8202.LLT-CFK								
Description	-25/1000	-50/1000	-25/1200	-50/1200	-25/1400	-50/1400	-25/1600	-50/1600
Article no.	4350127.61	4350127.62	4350127.63	4350127.64	4350127.65	4350127.66	4350127.67	4350127.68
Laser class	2M							
Measuring width	1000mm		1200mm		1400mm		1600mm	
Operating range	190mm							
Measuring range	40 mm	60mm	40 mm	60mm	40 mm	60mm	40 mm	60mm
Start of measuring range	500 mm	498,5 mm	500 mm	498,5 mm	500 mm	498,5 mm	500 mm	498,5 mm
Resolution	$\pm 0.5\mu\text{m}$	$\pm 0.8\mu\text{m}$	$\pm 0.5\mu\text{m}$	$\pm 0.8\mu\text{m}$	$\pm 0.5\mu\text{m}$	$\pm 0.8\mu\text{m}$	$\pm 0.5\mu\text{m}$	$\pm 0.8\mu\text{m}$
Repeatability ¹⁾	$\pm 0.25\mu\text{m}$	$\pm 0.4\mu\text{m}$	$\pm 0.25\mu\text{m}$	$\pm 0.4\mu\text{m}$	$\pm 0.25\mu\text{m}$	$\pm 0.4\mu\text{m}$	$\pm 0.25\mu\text{m}$	$\pm 0.4\mu\text{m}$
Absolute accuracy	$\pm 5\mu\text{m}$	$\pm 5\mu\text{m}$	$\pm 5\mu\text{m}$	$\pm 5\mu\text{m}$	$\pm 5\mu\text{m}$	$\pm 5\mu\text{m}$	$\pm 5\mu\text{m}$	$\pm 5\mu\text{m}$
Dimensions in mm (W ²⁾ x D x H)	1627x349x825		1827x349x825		2027x349x825		2027x349x825	
Weight	from 80 kg incl. packing							
Protection class ³⁾	IP54							
Ambient temperature ⁴⁾	min. +15°C max. +40°C							

¹⁾ Standard deviation over 50 measurements

²⁾ Width without linear axis

³⁾ without additional measures

⁴⁾ without additional cooling

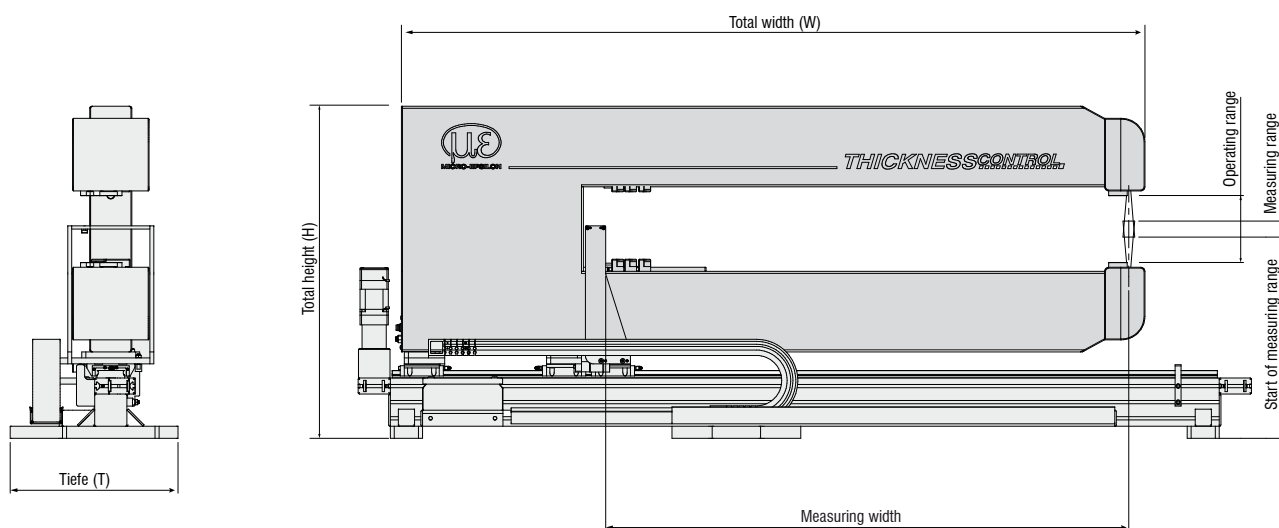

Example illustrating the dimensions

thicknessCONTROL MTS 8201.LLT

O-frame systems for profile thickness measurement



Due to its O-frame design, thicknessCONTROL MTS 8201.LLT is ideally suited to large widths and environments where there is insufficient space to position a C-frame alongside the production line. As well as the upper and lower boom, a linear axis is also integrated, on which a laser line sensor is installed. Both axes are mechanically coupled and move the sensors perpendicular to the strip run direction in order to measure the thickness profile. The measurement system is particularly suitable for slitting lines.

The high lateral resolution of the laser line enables high precision thickness measurements of each strip up to the edge. This is how every coil produced, even with very small widths, are evaluated and documented.

The large operating range of the thicknessCONTROL MTS 8201.LLT combined with high precision is important just after the cutter spindle, as the cutting process initiates vertical movements. Laser point sensors would not be able to provide the high precision at the measuring ranges required here.

From the different measurement techniques based on laser triangulation, the discrete laser line technology is the only method that compensates for tilt angle errors. This characteristic is a further, critical factor that ensures the outstanding accuracy of the system in such applications.

Also with measurements in front of the cutter, evaluation and documentation of individual stripes can be made when transmitting the cutter position.

Industry 4.0 for complex temperature requirements

thicknessCONTROL MTS 8201.LLT is equipped with a patented temperature compensation feature. The machine includes a special, thermally-stable frame as reference. With additional sensor technology, the changes of the measurement frame caused by temperature fluctuations are measured and compensated for using special algorithms. This is how the operating range of the system – of which the real, temperature-dependent, geometric change simulates a change in thickness – is kept virtually constant. This approach, which relies on the philosophy of Industry 4.0, is one of several features that make the thicknessCONTROL MTS 8201.LLT an extremely reliable and robust measurement system.

Special features:

- Patented compensation of parasitic, thermal effects
- Variable HMI positioning (integrated - standalone)
- Up to 60m/min traversing speed for large widths

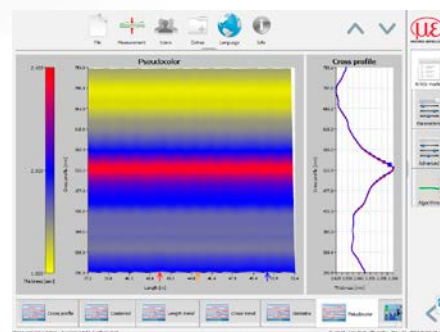

Screenshot false-colour-representation



Thickness measurement in a milling line

thicknessCONTROL MTS 8201.LLT

Description	-25/500	-50/500	-25/1000	-50/1000	-25/1500	-50/1500	-25/2000	-50/2000
Article no.	4350006.10	4350006.11	4350006.12	4350006.13	4350006.14	4350006.15	4350006.16	4350006.17
Laser class	2M							
Measuring width	500mm		1000mm		1500mm		2000mm	
Operating range	190mm	420mm	190mm	420mm	190mm	420mm	190mm	420mm
Measuring range	40mm	100mm	40mm	100mm	40mm	100mm	40mm	100mm
Start of measuring range	903mm	978mm	903mm	978mm	903mm	978mm	903mm	978mm
Resolution	$\pm 0.5\mu\text{m}$	$\pm 1\mu\text{m}$	$\pm 0.5\mu\text{m}$	$\pm 1\mu\text{m}$	$\pm 0.5\mu\text{m}$	$\pm 1\mu\text{m}$	$\pm 0.5\mu\text{m}$	$\pm 1\mu\text{m}$
Repeatability ¹⁾	$\pm 0.25\mu\text{m}$	$\pm 0.4\mu\text{m}$	$\pm 0.25\mu\text{m}$	$\pm 0.4\mu\text{m}$	$\pm 0.25\mu\text{m}$	$\pm 0.4\mu\text{m}$	$\pm 0.25\mu\text{m}$	$\pm 0.4\mu\text{m}$
Absolute precision	$\pm 5\mu\text{m}$	$\pm 10\mu\text{m}$	$\pm 5\mu\text{m}$	$\pm 10\mu\text{m}$	$\pm 5\mu\text{m}$	$\pm 10\mu\text{m}$	$\pm 5\mu\text{m}$	$\pm 10\mu\text{m}$
Dimensions in mm (W x D x H)	1776x450x1614	1776x450x1844	2276x450x1614	2267x450x1844	2776x450x1614	2776x450x1844	3276x450x1614	3276x450x1844
Weight	from 1200kg							
Protection class ²⁾	IP54							
Ambient temperature ³⁾	min. +15°C max. +40°C							

¹⁾ Standard deviation over 50 measurements

²⁾ without additional measures

³⁾ without additional cooling

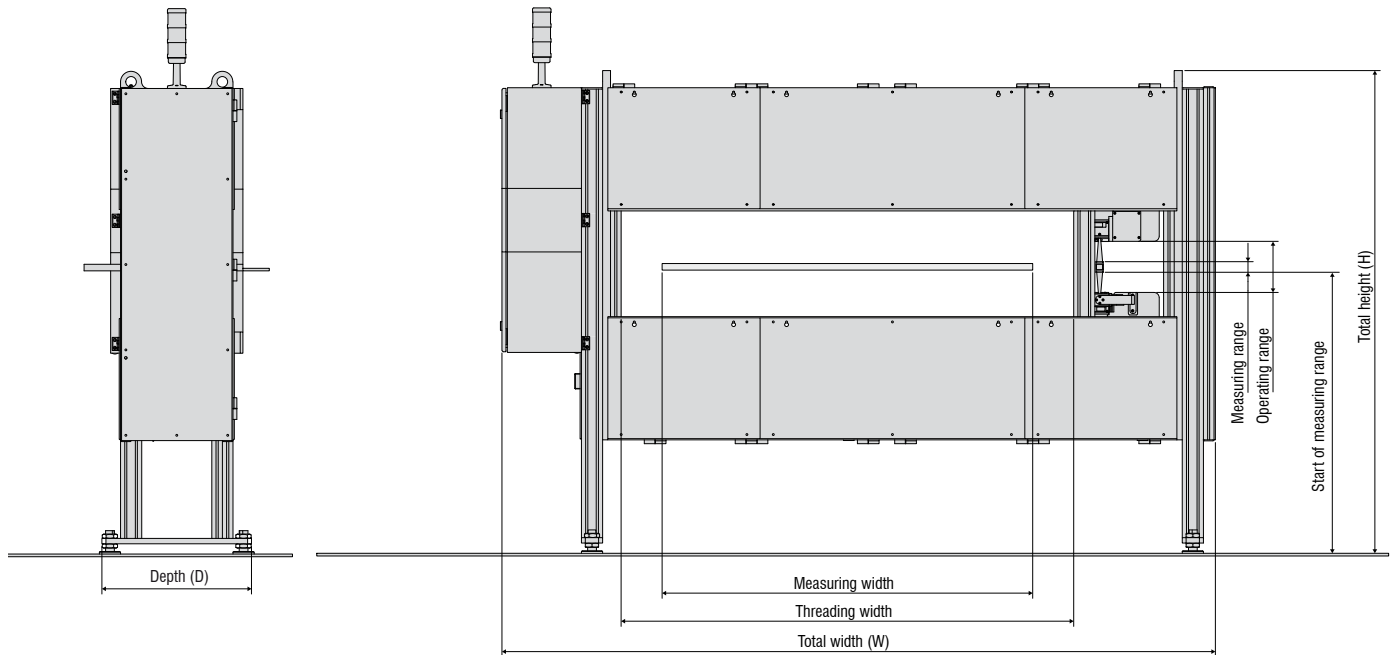

Example illustrating the dimensions

thicknessCONTROL MTS 9201.LLT

Special systems for special applications



thickness CONTROL MTS 9201.LLT is specially designed for applications in harshest environments for example aluminum hot rolling mills.

These systems stand out due to their solid steel frame. The optical sensors are water-cooled in order to ensure a longer service life. The integrated, electronic components remain in the specified temperature range, as the frame is purged with cold air. Another special feature is the patented, fully automatic monitoring of the linearity in the 'parked' position using a certified calibration standard. In this way, not only are thermal effects on the mechanics of the measuring frame are monitored but also the factors affecting the sensor electronics, which are corrected automatically using a patented linearisation process.

Extended measuring range with unchanged precision

All O-frame systems, particularly the HME variant, can be retrofitted with a vertical linear axis in the upper boom.

This is how the measuring range of the machine can be extended significantly without changing the sensor measuring range and the accuracy.

The axis is also considered in the temperature compensation management and can be regulated in its position to the line with reference to the expected thickness via the interface.

Offline tools for comprehensive analyses

As well as comprehensive visualisation possibilities, thicknessCONTROL MTS offers an offline tool that enables detailed analyses of production and its optimisation based on SPC functionality.

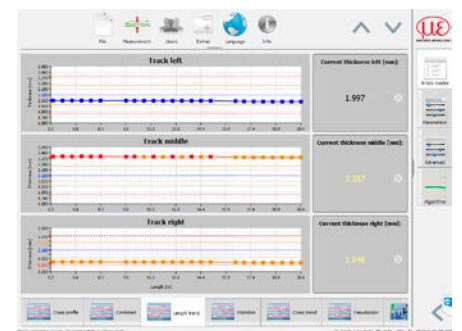

Screenshot trend for edge and centre thickness



Thickness measurement in an aluminium hot rolling mill

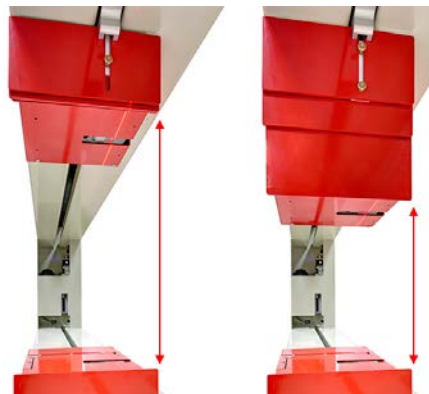

Vertical adjustment of the upper sensor head

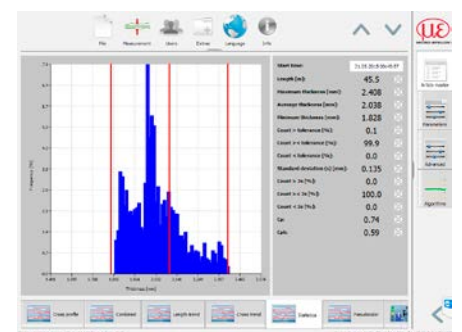

Screenshot statistical evaluation of production



Unique
Innovative
Superior
Efficient
Revolutionary

thicknessCONTROL MWS 8201.LLT

Dynamic width measurement using discrete laser line technology



Using discrete laser line sensors, the thicknessCONTROL MWS 8201.LLT enables the inspection of the strip edges due to the high lateral resolution. Width can be measured using one sensor on every edge of the strip.

Both sensors are mounted onto mechanical carriages on a portal, and can be positioned independently from one another. The position/distance of the mechanical carriages can be detected using a linear encoder.

The arrangement of the sensors in the mechanical carriages is determined during a calibration procedure. The encoder value and the sensor signals in the x-axis amount to the strip width. As laser line sensors deliver a two-dimensional signal, the material tilt angle can also be taken into account and compensated.

Combined measurement technology for thickness and width

thicknessCONTROL MWS 8201.LLT combines thickness and width measurement in an O-frame system which is equipped with three laser line sensors. Two sensors are integrated into the upper boom and one in the lower boom. However, one sensor in the upper boom is used for both measurement tasks. While the sensor technology of the thickness measurement continuously detects the thickness profile while traversing, the width is always measured when both sensors are positioned in the upper boom on one edge. This system architecture is predestined for monitoring and process optimisation of slitting lines, as the thickness and the width can be continuously monitored and documented for each individual ring.

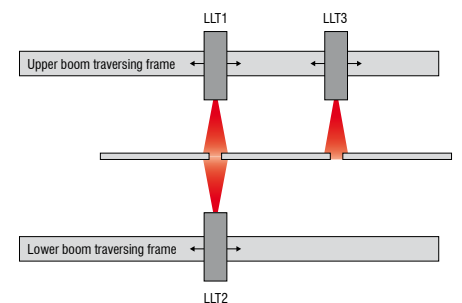

Functional principle of combined thickness and width measurement

Integrated width measurement for slitting lines

The third LLT3 laser scanner traverses independently of both thickness measurement scanners (LLT1 and 2) and therefore provides the exact width value of the individual rings.

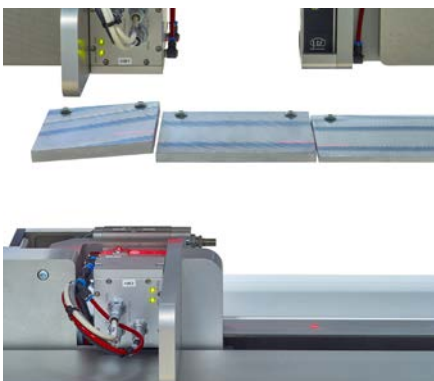

Combined thickness and width measurement



Calibration of sensor position



Measurement after slitting shears

thicknessCONTROL MWS 8201.LLT

Description	-25/500	-50/500	-25/1000	-50/1000	-25/1500	-50/1500	-25/2000	-50/2000
Article no.	4350282.01	4350282.02	4350282.03	4350282.04	4350282.05	4350282.06	4350282.07	4350282.08
Laser class	2M							
Measuring width	500mm		1000mm		1500mm		2000mm	
Thickness operating range	190mm	420mm	190mm	420mm	190mm	420mm	190mm	420mm
Thickness measuring range	40mm	100mm	40mm	100mm	40mm	100mm	40mm	100mm
Thickness start of measuring range	903mm	978mm	903mm	978mm	903mm	978mm	903mm	978mm
Thickness resolution	$\pm 0.5\mu\text{m}$	$\pm 1\mu\text{m}$	$\pm 0.5\mu\text{m}$	$\pm 1\mu\text{m}$	$\pm 0.5\mu\text{m}$	$\pm 1\mu\text{m}$	$\pm 0.5\mu\text{m}$	$\pm 1\mu\text{m}$
Thickness repeatability ¹⁾	$\pm 0.25\mu\text{m}$	$\pm 0.4\mu\text{m}$	$\pm 0.25\mu\text{m}$	$\pm 0.4\mu\text{m}$	$\pm 0.25\mu\text{m}$	$\pm 0.4\mu\text{m}$	$\pm 0.25\mu\text{m}$	$\pm 0.4\mu\text{m}$
Thickness absolute accuracy	$\pm 5\mu\text{m}$	$\pm 10\mu\text{m}$	$\pm 5\mu\text{m}$	$\pm 10\mu\text{m}$	$\pm 5\mu\text{m}$	$\pm 10\mu\text{m}$	$\pm 5\mu\text{m}$	$\pm 10\mu\text{m}$
Width resolution	$\pm 20\mu\text{m}$							
Width repeatability ¹⁾	$\pm 25\mu\text{m}$							
Dimensions in mm (W x D x H)	1776x450x1614	1776x450x1844	2276x450x1614	2267x450x1844	2776x450x1614	2776x450x1844	3276x450x1614	3276x450x1844
Weight	ab 1200 kg							
Protection class ²⁾	IP54							
Ambient temperature ³⁾	min. +15°C max. +40°C							

¹⁾ Standard deviation over 50 measurements

²⁾ without additional measures

³⁾ without additional cooling

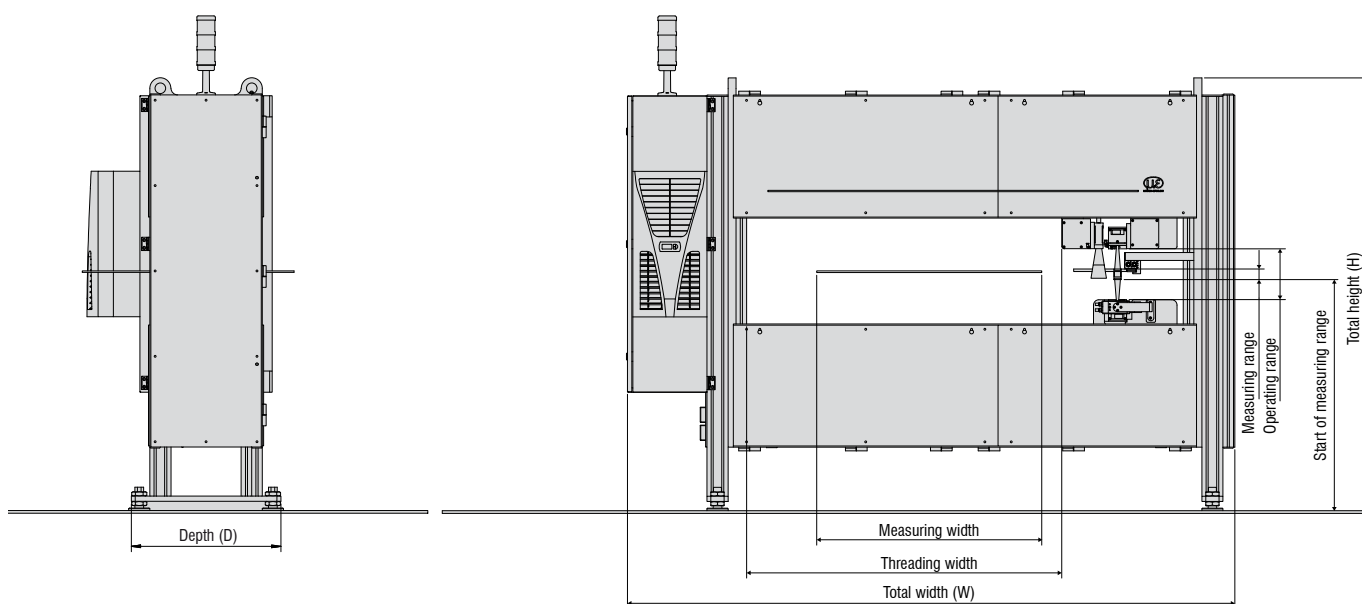

Example illustrating the dimensions

thicknessCONTROL MTS

INDUSTRY 4.0 – high precision measurement data

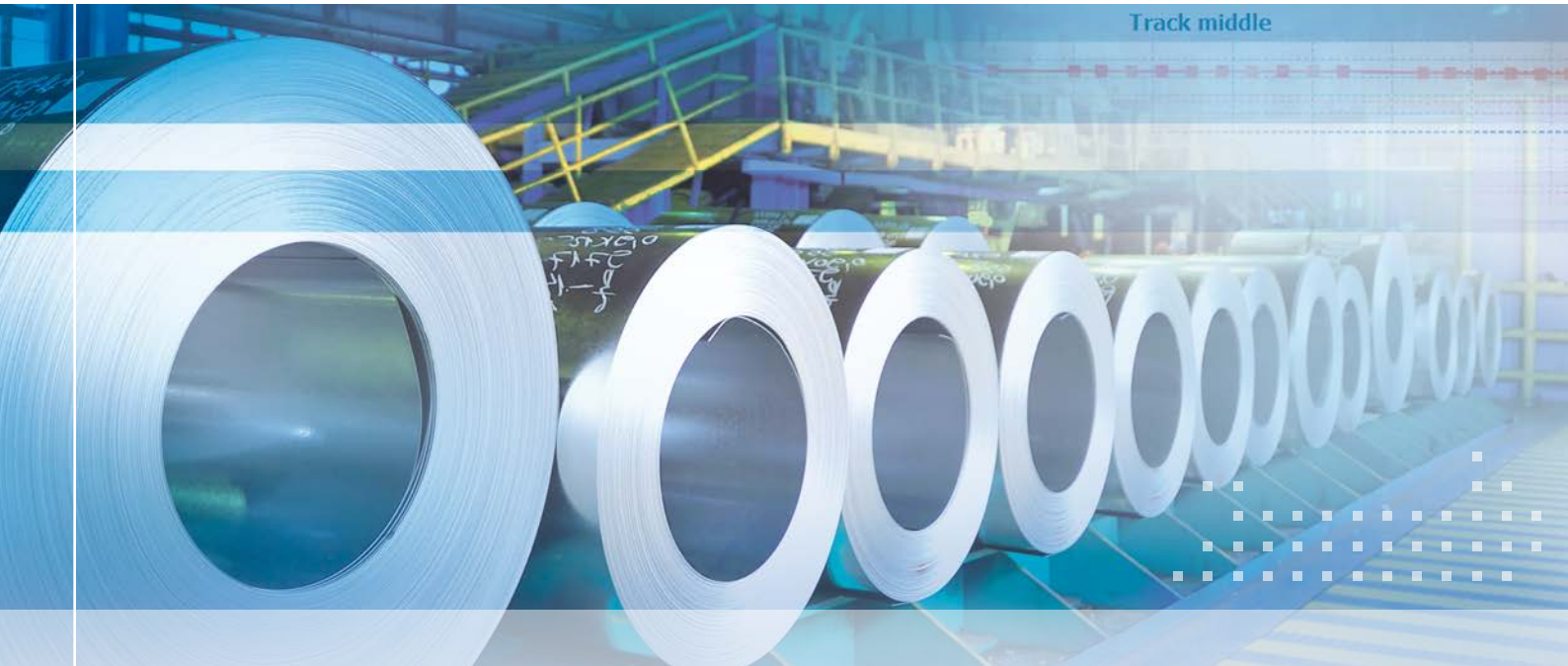

The precision of measurement data reflects the efficiency of production. This means more than simply monitoring the production tolerances, it is the source of current and future optimisation. The infrastructure, which is now widely available, distributes this measurement data, generating knowledge and enabling the necessary decisions to be made that in turn will result in the most productive, flexible production systems.

As a matter of course, ensuring the easy integration of these measurement systems into production lines is essential.

thicknessCONTROL MTS systems have flexible interfaces with different media and reports, which enable a comprehensive data exchange of

- Batch- and process-oriented measurement data
- Customer-specific recipes (tolerances)
- Machine states (temperature, calibration window)
- Automatically generated gauge capability parameters
- Wear parameters

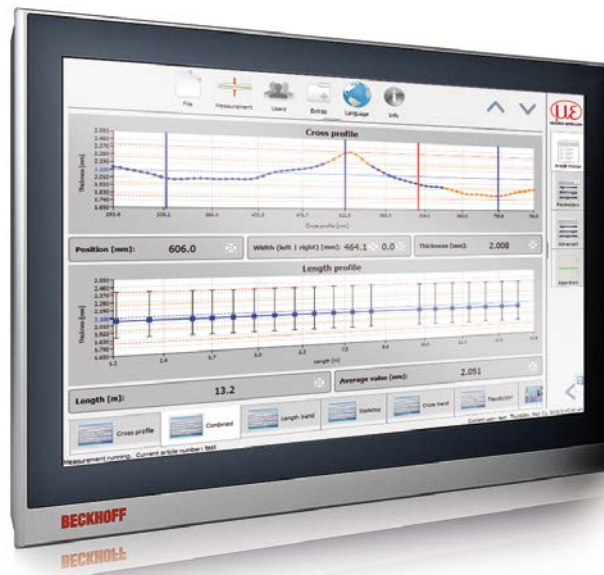

Flexible human-machine interfaces. MTS measurement systems have a multi-touchscreen user interface which enables zooming and the selection of diagrams and profile views by swiping.

Parameters can be set up quickly and easily in a method similar to a smartphone. HMI positioning is flexible. It can be directly installed into the machine, into a separate machine or into an existing switch room.

Micro-Epsilon in the metals industry

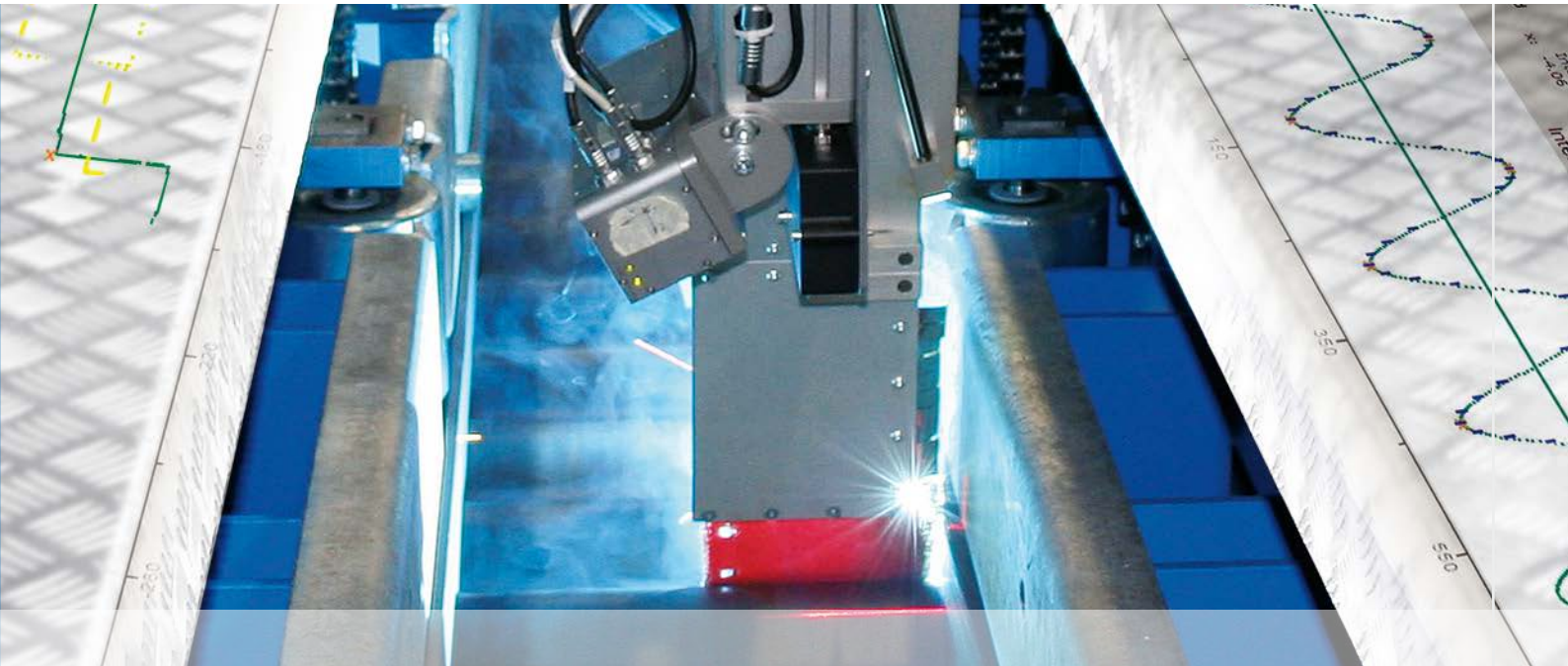

Micro-Epsilon is a reliable industrial partner since more than 40 years for precision measurement technology used in inspection, monitoring and automation.

Systems and components from Micro-Epsilon are used in the metals industry and in metal processing in order to develop more efficient production. The areas of application for these measurement systems range from the milling process through to the final product.

800 employees worldwide provide Europe's most comprehensive range of measurement technologies for thickness, width, profile and surface measurement, as well as systems for measuring temperature, colour, vibration, impact, gap and many other features.

As components, these are often indispensable and are integral parts in the products of many machine builders, systems integrators and electrical equipment suppliers worldwide. A specialist in measurement technologies, Micro-Epsilon is also renowned for providing custom measurement solutions that fulfill the highest requirements in processing lines. Solutions are devised in the shortest time and matched on site.



Sensors:

worldwide marketed and experienced sensors as a basis of the system

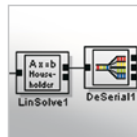

Software:

graphical development platform guarantees group-wide synergistic effects



Mechanics:

high quality mechanical design, mechanical manufacturing and assembly



Automation:

electrical design and assembly



Service:

24/7 technical support

Your local support



Successful installations in the following countries



MICRO-EPSILON

More precision for added value

Performance and quality, as well as reliability of products and services have made Micro-Epsilon Messtechnik GmbH & Co. KG one of the leading suppliers of inspection systems for optical thickness measurement used in the metals industry. Numerous, successful installations in 13 countries around the world in milling lines and processing lines speak for themselves. Developing and producing all the necessary core components such as sensors, software and measurement-specific machine building inside the company group provides unique innovative skills that are mirrored in the product portfolio of Micro Epsilon.

MICRO-EPSILON MESSTECHNIK GmbH & Co. KG
Koenigbacher Str. 15 · 94496 Ortenburg / Germany
Tel. +49 (0) 8542 / 168-0 · Fax +49 (0) 8542 / 168-90
info@micro-epsilon.com · www.micro-epsilon.com