

Nozzle Heaters

Nozzle Heaters	Sheath Materials	Max. Operating Temperatures		Typical Max. Watt Densities		Page
		°F	°C	W/in ²	W/cm ²	
Mineral Insulated (MI)	Stainless steel	1400	760	230	35.6	507
Pre-Coiled Cable	Stainless steel	1200	650	152	23.5	509





Nozzle Heaters

Mineral Insulated (MI) Nozzle Heaters

The mineral insulated (MI) nozzle heater is a high-performance heater that incorporates Watlow's exclusive mineral insulation technology. This material offers much higher thermal conductivity than mica and hard ceramic insulators used in conventional heaters.

A thin layer of the high thermal conductive MI material electrically insulates the element wire from the inside diameter of the heater sheath. A thicker, low thermal conductivity layer backs up the element wire, directing the heat inward toward the heated part. The result is more efficient heat transfer—a performance solution that lowers element wire temperatures and increases heater life.

Performance Capabilities

- Heater operating temperatures up to 1400°F (760°C)
- Watt densities up to 230 W/in² (35.6 W/cm²) are available on small diameter nozzle
- Maximum voltage up to 240V

Features and Benefits

Operating temperatures up to 1400°F (760°C)

- Melts resins such as PEEK®, Teflon®, Ultem® and Zytel® safely

Higher watt densities

- Contributes to faster heat-up and throughput for increased productivity

High thermal conductivity of MI and low mass construction

- Provides an almost instant response to temperature control
- Eliminates thermal lag and temperature overshoot

Stainless steel cover and side fold design

- Resists contamination by overflow of plastic or other free-flowing materials

Permanently attached clamp bars

- Eliminates cumbersome clamping straps to ease installation

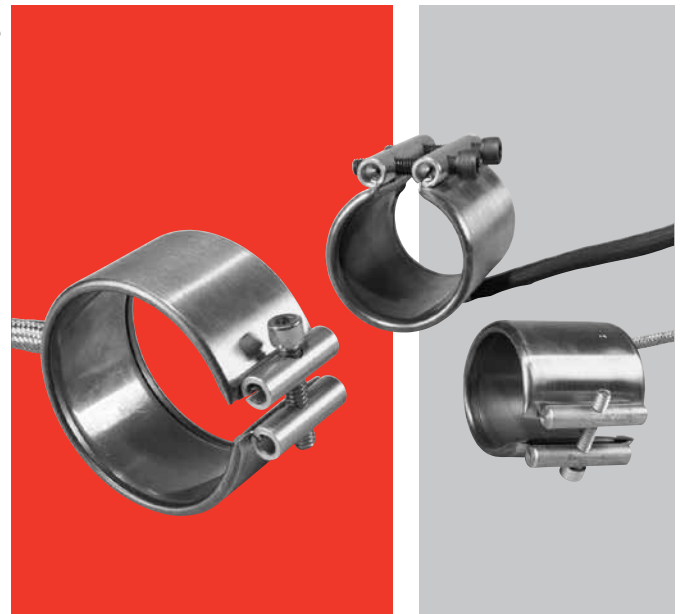

Typical Applications

- Extruders
- Blown film dies
- Injection molding machines
- Other cylinder heating applications

**For MI nozzle heater part numbers see next page.
For detailed product and technical data,
see the full MI Band Heater product
section located on pages 493 through 502.**

Nozzle Heaters

Mineral Insulated (MI) Nozzle Heaters

Heater Part Numbers

I.D. in. (mm)	Width		Construction	Volts	Watts	Watt Density		Termination	Approx. Net Wt.		Del.	Part Number
	in. (mm)	(mm)				W/in ²	(W/cm ²)		lbs.	(kg)		
1 (25)	1 (25)	(25)	1 pc	120	150	92	(14)	Type B, C, E, F or H	0.1	(0.05)	RS	MB1A1AN1
	1 (25)	(25)	1 pc	120	100	61	(9)	Type B, C, E, F or H	0.1	(0.05)	RS	MB1A1AN2
	1 (25)	(25)	1 pc	120	200	122	(19)	Type B, C, E, F or H	0.1	(0.05)	RS	MB1A1AN3
	1 (25)	(25)	1 pc	240	200	122	(19)	Type B, C, E, F or H	0.1	(0.05)	RS	MB1A1AN4
	1 1/2 (38)	(38)	1 pc	240	300	106	(16)	Type B, C, E, F or H	0.1	(0.05)	RS	MB1A1JN1
	1 1/2 (38)	(38)	1 pc	120	300	106	(16)	Type B, C, E, F or H	0.1	(0.05)	RS	MB1A1JN2
	1 1/2 (38)	(38)	1 pc	240	200	70	(11)	Type B, C, E, F or H	0.1	(0.05)	RS	MB1A1JN3
	1 1/2 (38)	(38)	1 pc	120	200	70	(11)	Type B, C, E, F or H	0.1	(0.05)	M	MB1A1JN4
1 1/4 (32)	1 (25)	(25)	1 pc	240	250	104	(16)	Type B, C, E, F or H	0.1	(0.05)	RS	MB1E1AN1
	1 (25)	(25)	1 pc	120	250	104	(16)	Type B, C, E, F or H	0.1	(0.05)	RS	MB1E1AN2
	1 (25)	(25)	1 pc	240	300	124	(19)	Type B, C, E, F or H	0.1	(0.05)	M	MB1E1AN3
	1 1/2 (38)	(38)	1 pc	240	350	87	(13)	Type B, C, E, F or H	0.2	(0.09)	RS	MB1E1JN1
	1 1/2 (38)	(38)	1 pc	120	350	87	(13)	Type B, C, E, F or H	0.2	(0.09)	RS	MB1E1JN2
	1 1/2 (38)	(38)	1 pc	240	450	112	(17)	Type B, C, E, F or H	0.2	(0.09)	M	MB1E1JN3
1 1/2 (38)	1 (25)	(25)	1 pc	240	300	93	(14)	Type B, C, E, F or H	0.1	(0.05)	M	MB1J1AN1
	1 (25)	(25)	1 pc	120	300	93	(14)	Type B, C, E, F or H	0.1	(0.05)	RS	MB1J1AN2
	1 (25)	(25)	1 pc	240	200	62	(10)	Type B, C, E, F or H	0.1	(0.05)	RS	MB1J1AN3
	1 (25)	(25)	1 pc	120	200	62	(10)	Type B, C, E, F or H	0.1	(0.05)	RS	MB1J1AN4
	1 (25)	(25)	1 pc	240	400	125	(19)	Type B, C, E, F or H	0.1	(0.05)	RS	MB1J1AN5
	1 1/2 (38)	(38)	1 pc	120	300	58	(9)	Type B, C, E, F or H	0.2	(0.09)	RS	MB1J1JN1
	1 1/2 (38)	(38)	1 pc	240	450	87	(14)	Type B, C, E, F or H	0.2	(0.09)	RS	MB1J1JN2
	1 1/2 (38)	(38)	1 pc	240	300	58	(9.0)	Type B, C, E, F or H	0.2	(0.09)	RS	MB1J1JN3
	1 1/2 (38)	(38)	1 pc	240	600	116	(18)	Type B, C, E, F or H	0.2	(0.09)	M	MB1J1JN4
	1 1/2 (38)	(38)	1 pc	240	300	64	(10)	Post	0.2	(0.09)	M	MB1J1JP4
	1 1/2 (38)	(38)	1 pc	240	450	96	(15)	Post	0.2	(0.09)	RS	MB1J1JP6
	2 (51)	(51)	1 pc	240	450	57	(9)	Type B, C, E, F or H	0.3	(0.14)	RS	MB1J2AN1
	2 (51)	(51)	1 pc	240	300	42	(7)	Type B, C, E, F or H	0.3	(0.14)	RS	MB1J2AN2
	2 (51)	(51)	1 pc	240	900	125	(19)	Type B, C, E, F or H	0.3	(0.14)	RS	MB1J2AN3
	3 (76)	(76)	1 pc	240	500	45	(7)	Type B, C, E, F or H	0.4	(0.18)	RS	MB1J3AN1
	3 (76)	(76)	1 pc	240	350	31	(5)	Type B, C, E, F or H	0.4	(0.18)	M	MB1J3AN2
	3 (76)	(76)	1 pc	240	1000	104	(16)	Type B, C, E, F or H	0.4	(0.18)	M	MB1J3AN3
	1 3/4 (45)	1 3/8 (35)	(35)	1 pc	240	450	83	(13)	36 in. 90° Type B braid w/HD strain relief	0.2	(0.09)	RS
1 1/2 (38)		(38)	1 pc	240	300	47	(7)	Type B, C, E, F or H	0.2	(0.09)	RS	MB1N1JN1
1 1/2 (38)		(38)	1 pc	120	300	50	(8)	Type B, C, E, F or H	0.2	(0.09)	RS	MB1N1JN2
1 1/2 (38)		(38)	1 pc	240	700	110	(17)	Type B, C, E, F or H	0.2	(0.09)	RS	MB1N1JN3
2 (51)		(51)	1 pc	240	750	86	(13)	Type B, C, E, F or H	0.3	(0.14)	M	MB1N2AN1
2 (51)	1 (25)	(25)	1 pc	240	350	73	(11)	Type B, C, E, F or H	0.2	(0.09)	RS	MB2A1AN1
	1 (25)	(25)	1 pc	120	350	73	(11)	Type B, C, E, F or H	0.2	(0.09)	RS	MB2A1AN2
	1 (25)	(25)	1 pc	240	450	94	(15)	Type B, C, E, F or H	0.2	(0.09)	RS	MB2A1AN3
	1 (25)	(25)	1 pc	240	350	79	(12)	36 in. 90° Type B braid w/HD strain relief	0.2	(0.09)	RS	MB2A1AX6B
	1 1/2 (38)	(38)	1 pc	240	400	53	(8)	Type B, C, E, F or H	0.3	(0.14)	RS	MB2A1JN1
	1 1/2 (38)	(38)	1 pc	240	1000	132	(21)	Type B, C, E, F or H	0.3	(0.14)	M	MB2A1JN2
	2 (51)	(51)	1 pc	240	750	73	(11)	Type B, C, E, F or H	0.4	(0.18)	M	MB2A2AN1
	2 (51)	(51)	1 pc	240	1200	125	(19)	Type B, C, E, F or H	0.4	(0.18)	RS	MB2A2AN2
2 1/4 (57)	2 (51)	(51)	1 pc	240	750	63	(10)	120 in. 180° Type B braid w/HD strain relief	0.2	(0.09)	RS	MB2E2AX7
	2 1/2 (64)	(64)	1 pc	240	1000	72	(11)	Type B, C, E, F or H	0.5	(0.23)	RS	MB2E2JN1
2 1/2 (64)	1 (25)	(25)	1 pc	240	400	63	(10)	Type B, C, E, F or H	0.2	(0.09)	RS	MB2J1AN1
	1 1/2 (38)	(38)	1 pc	240	500	50	(8)	Type B, C, E, F or H	0.4	(0.18)	RS	MB2J1JN1

RAPID SHIP

- **RS** - Next day shipment
- **M** - Manufacturing lead times

Nozzle Heaters

Pre-Coiled Cable Nozzle Heaters

The Watlow pre-coiled, cable nozzle heater has been formed into a compact, tightly wound coil to supply 360 degrees of heat. This heater features a 5 in. (127 mm) long, no-heat tail section, which eliminates failures in the adapter area due to overheating.

This cable nozzle heater is manufactured with Watlow's swaged compaction process. This process provides a greater compaction of the MgO insulation than the competitor's rolling process. Compacting MgO insulation into a solid mass results in excellent heat conductivity and high dielectric strength.

Performance Capabilities

- Watt density up to 100 W/in² (15.5 W/cm²)
- Possible operating temperature up to 1200°F (650°C) (Dependent on type of element wire used)
- 230 and 240V constructions

Features and Benefits

Low-profile construction

- Provides easy installation in the tight environment of multiple-gate molds

No-heat tail section

- Reduces temperature at the adapter eliminating failures due to overheating

Single tail with dual lead

- Occupies less space in the wire raceway

360° circumference heat

- Provides even heating

Optional externally welded thermocouple to the sheath

- Provides temperature measurement capabilities

Typical Applications

- Plastic injection molding equipment
- Hot runner molds

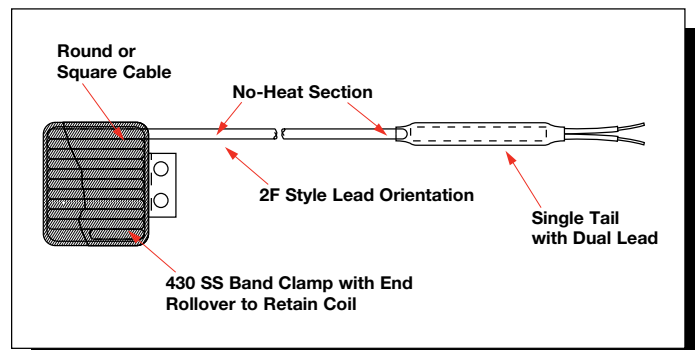

Nozzle Heaters

Pre-Coiled Cable Nozzle Heaters

Technical Data

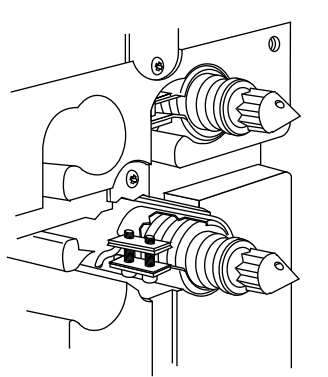

Coiled Nozzle Heaters Mounted on a 64 Cavity Plastic Injection Mold

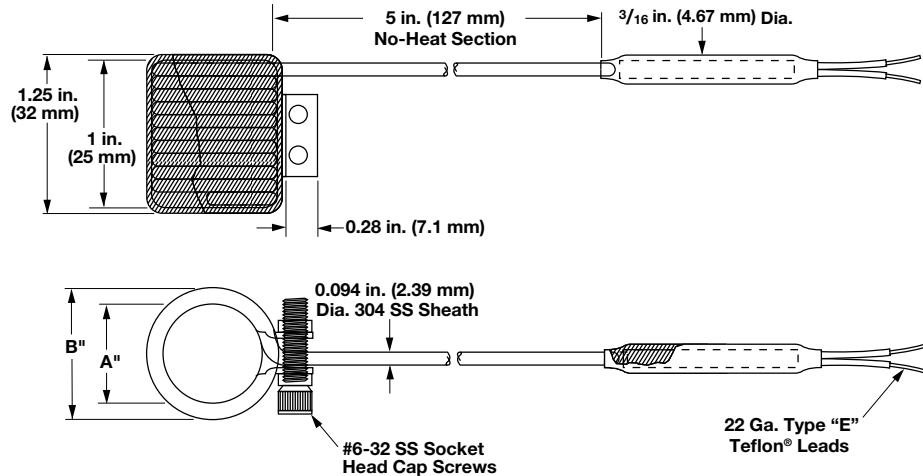

Cable Heater Units (Coiled nozzle with clamp strap)

Volts	Watts	Coil I.D. in. (mm)	Clamp O.D. in. (mm)	Clamp Width in. (mm)	No-Heat	Lead Wire (Swaged-in) PTFE Only	Part Number
-------	-------	-----------------------	------------------------	-------------------------	---------	---------------------------------------	-------------

0.094 in. Diameter Round (with ±5% wattage tolerance), no lead protection available.

230	125	0.75 (19.0)	0.98 (24.9)	1.25 (32)	5 in. (127 mm) only	36 in. (914 mm)	94PC30A1A
230	125	0.75 (19.0)	0.98 (24.9)	1.25 (32)		72 in. (1829 mm)	94PC30A1D
230	250	0.75 (19.0)	0.98 (24.9)	1.25 (32)	5 in. (127 mm) only	36 in. (914 mm)	94PC30A2A
230	250	0.75 (19.0)	0.98 (24.9)	1.25 (32)		72 in. (1829 mm)	94PC30A2D
230	250	0.75 (19.0)	0.98 (24.9)	1.25 (32)		36 in. (914 mm)	94PC30A4A ^①

0.102 in. Square Cross-Section (with ±5% wattage tolerance), no lead protection available.

230	125	0.75 (19.0)	1 (25.0)	1.25 (32)	5 in. (127 mm) only	36 in. (914 mm)	102PS28A2B
230	125	0.75 (19.0)	1 (25.0)	1.25 (32)		72 in. (1829 mm)	102PS28A2A
230	250	0.75 (19.0)	1 (25.0)	1.25 (32)	5 in. (127 mm) only	36 in. (914 mm)	102PS28A1B
230	250	0.75 (19.0)	1 (25.0)	1.25 (32)		72 in. (1829 mm)	102PS28A4A ^①
230	250	0.875 (22.2)	1.12 (28.5)	1.25 (32)		36 in. (914 mm)	102PS32A1A

- Delivery, 1 to 3 working days

^① Units have a 36 in. (914 mm) fiberglass insulated Type J thermocouple externally brazed to the heater sheath O.D.

0.058 in. Diameter Round Mini-Cable Nozzle Heater

(Coiled nozzle with axial clamp)
(with ±5% wattage tolerance)

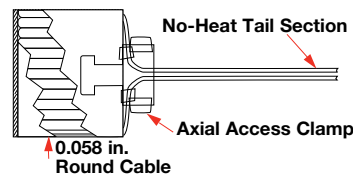

Coil I.D. in. (mm)	Volts	Watts	Lead Length in. (mm)	Clamp Width in. (mm)	Cable Type	Part No.
0.75 (19)	240	268	72 (1829)	1.25 (32)	Round	Z5969
0.75 (19)	240	149	72 (1829)	1.25 (32)	Round	Z5968

- Delivery, 1 to 3 working days

Note: An optional Type J or Type K thermocouple can be externally brazed to the sheath O.D.