



Ortlinghaus

Cee.*go*



Ortlinghaus

Founded in: 1898
Employees: 500+
Subsidiaries: Ortlinghaus (U.K.) Ltd.
 Ortlinghaus France / France
 Ortlinghaus AG / Switzerland
 Ortlinghaus International Trading Shanghai / China
 Ortlinghaus Drive Technology India Pvt.Ltd. / India
 OOO "Ortlinghaus RUS" / Russia
Manufacturing: Wermelskirchen / Germany
 Gams / Switzerland
Sales: Worldwide via agencies

Development.

We have been active in the press technology industry for more than 75 years. Today, we offer products across the entire spectrum of mechanical presses and servo presses, from clutch-brake combinations and brakes to compact drives and mechatronic control technology.

We are the only manufacturer to successfully combine building clutches with producing plate linings and mechatronic systems. Ortlinghaus has developed a reputation for quality throughout the world – and we are highly motivated to meet and exceed our previous standards. We work with our customers to create custom solutions that are characterized by innovation and superior engineering.

With the Cee.go, our innovative clutch-brake combination for C-frame presses, we have raised the bar yet again. The system is wet-running and pneumatically actuated while increasing the overall equipment effectiveness. The Cee.go boasts a series of technical innovations and advantages that make its operation more efficient and cost-effective.



Cee.go

Change in Progress.

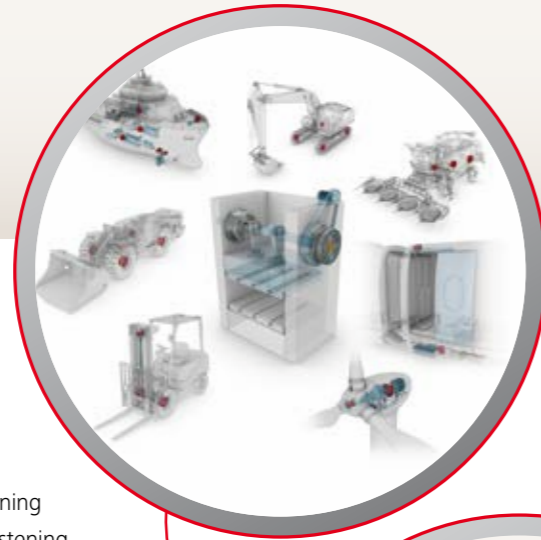

Industry Management.

Ortlinghaus has developed a fine-tuned process for turning ideas into successful products. The process begins with listening to the market. We do so in industry groups that are focused on specific markets and applications.

One of our key markets is the press technology market. More than 75 years in this market have allowed us to develop a deep understanding of the needs of press manufacturers and users.

Product-/Technology Strategy.

A structured and analytical product and technology strategy process is used in order to fulfill the needs and requirements of press customers. The market strategies are always accompanied and complemented by technology strategies. Through this combination, it is possible to create product / technology roadmaps that are focused on developing products and systems that are relevant for clients quickly and efficiently.

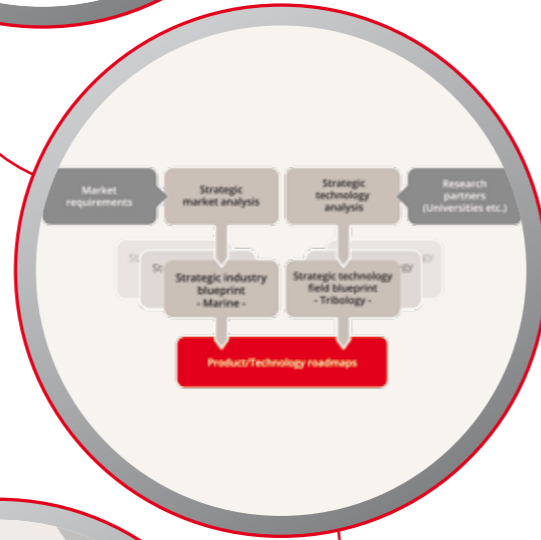

Market Strategy.

Our markets are classified according to their attractiveness and stability. The market for C presses is one of the most attractive segments in the press technology market. The past few years have seen considerable change in this market as consumer goods have become increasingly available globally. The result of this has been front-loaded production curves requiring faster presses of a higher quality for the same price.

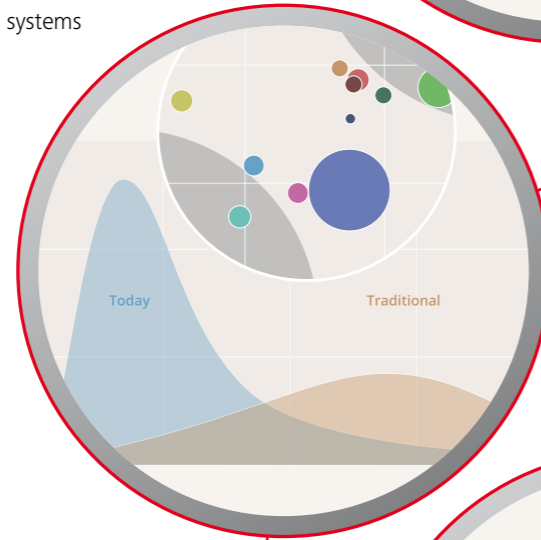

Market Requirements.

Ortlinghaus has taken on this challenge and set out to engineer a product that is designed-to-cost. It should have a higher productivity than comparable products while still delivering the same level of Ortlinghaus quality.

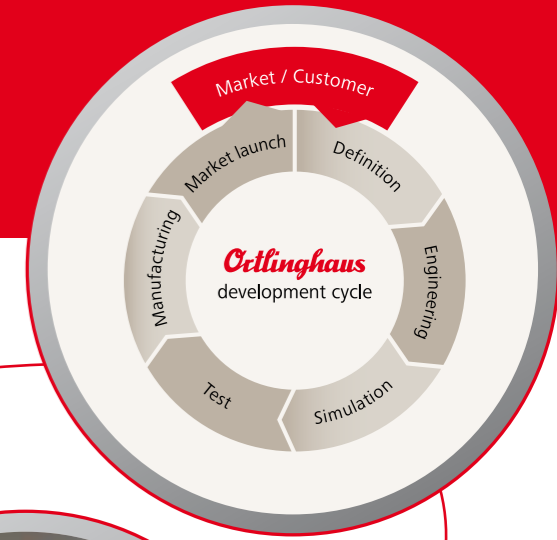
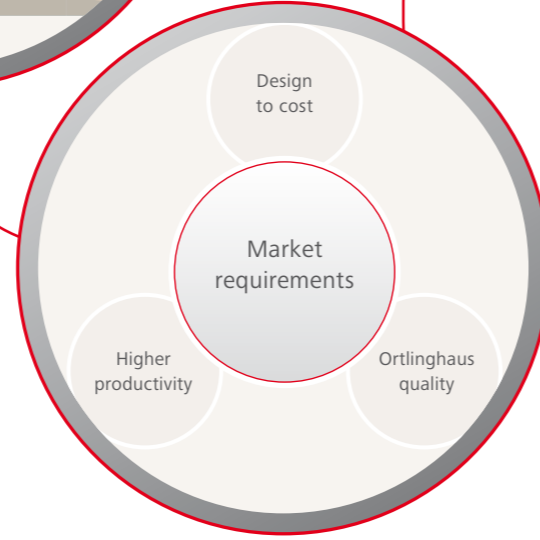

Development Cycle.

Our development cycle is a well-defined process that reduces time-to-market significantly.

Engineering.

Once market requirements have been defined, the engineering process step begins. Ortlinghaus draws from a large pool of technology concepts. Our engineers receive training to keep them up-to-date on the latest developments in tribology, mechatronics and engineering concepts.

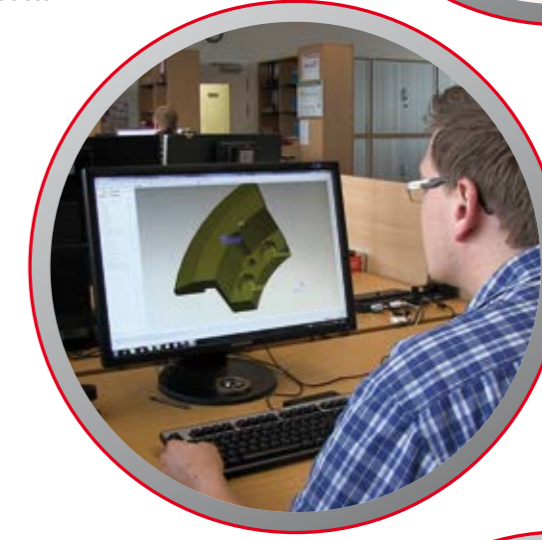

Simulation.

Following completion of the engineering step, the simulation process step is initiated. We have developed sophisticated software to simulate thermal loads during the use of our brakes and clutches. Proprietary software packages allow us to calculate and simulate idle running losses.

This facilitates the optimization of new products.



Industrialization.

The final step in this process is industrialization. Here the work from the engineering and simulation phases comes together. The focus is on achieving the target costs while maintaining Ortlinghaus Quality.

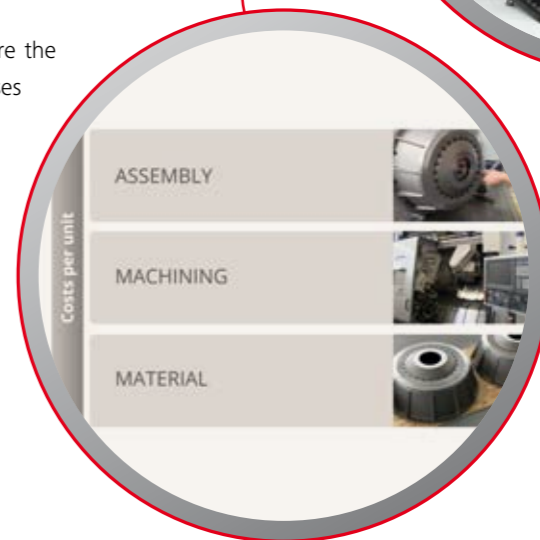

Change in Progress.

Cee.go

The Cee.go is a new kind of clutch/brake combination for C-frame presses, which are used to manufacture consumer products such as smartphones and DVD players. It is a pneumatically actuated clutch/brake combination, which is wet-running with an internal cooling oil supply.

The Cee.go has been engineered as a complete system. There is no need to install an external cooling oil supply, simplifying the assembly process at the press. Cee.go is wet-running and its sturdy design ensures a very long service life.

It also has increased productivity when compared to similar products, as it can complete a higher number of press strokes.

Material Costs.

Material costs are primarily determined during design. By integrating trusted suppliers into the supply chain, we are able to achieve the targeted material costs.

Machining.

We constantly invest in the best equipment available and have aligned our machine shop organization and structure to achieve economies of scale and scope. Doing so is essential for manufacturing in a cost effective manner.

Assembly.

The concept of achieving hyper-efficiency is applied to the assembly process as well. Every step in this process is simulated and mapped, thus helping us achieve our target costs.

Final Product.

The end result of this process is the Cee.go.

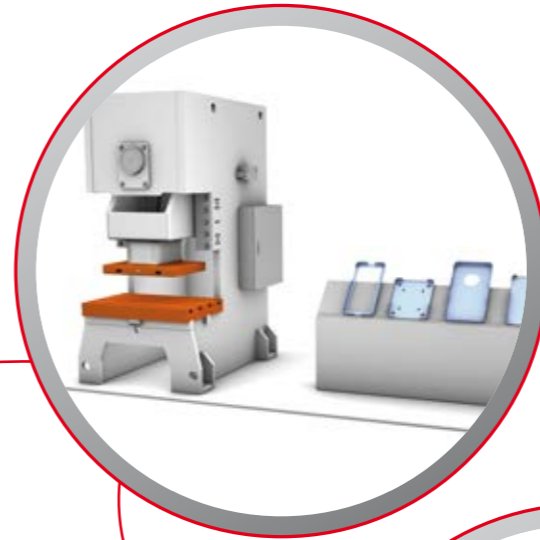
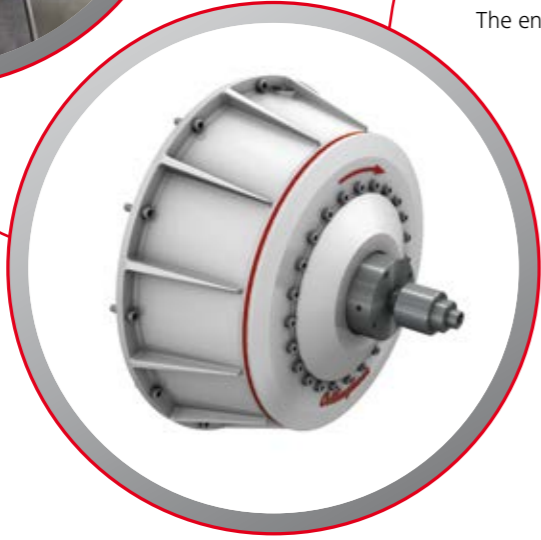
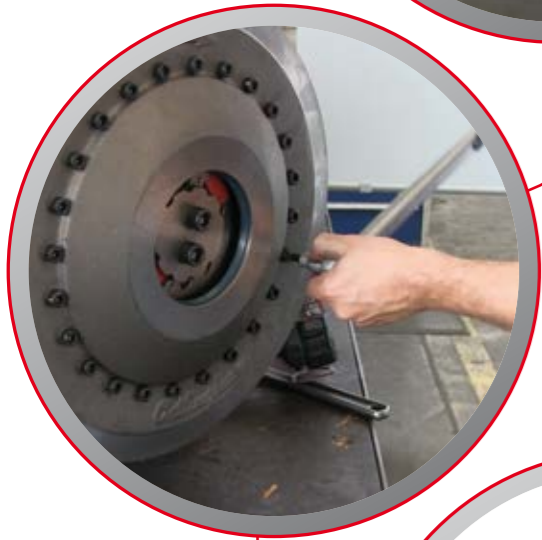
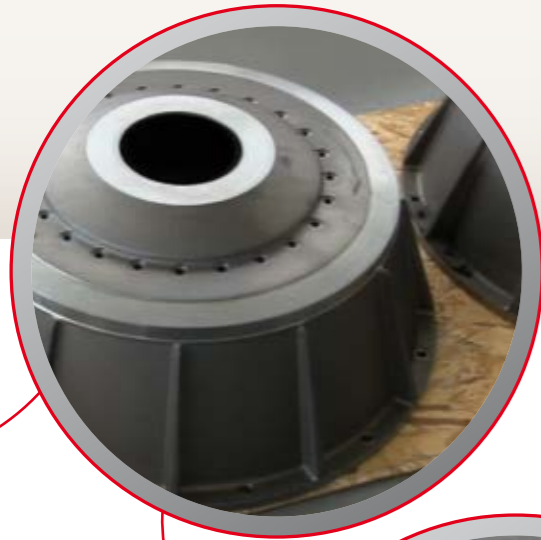

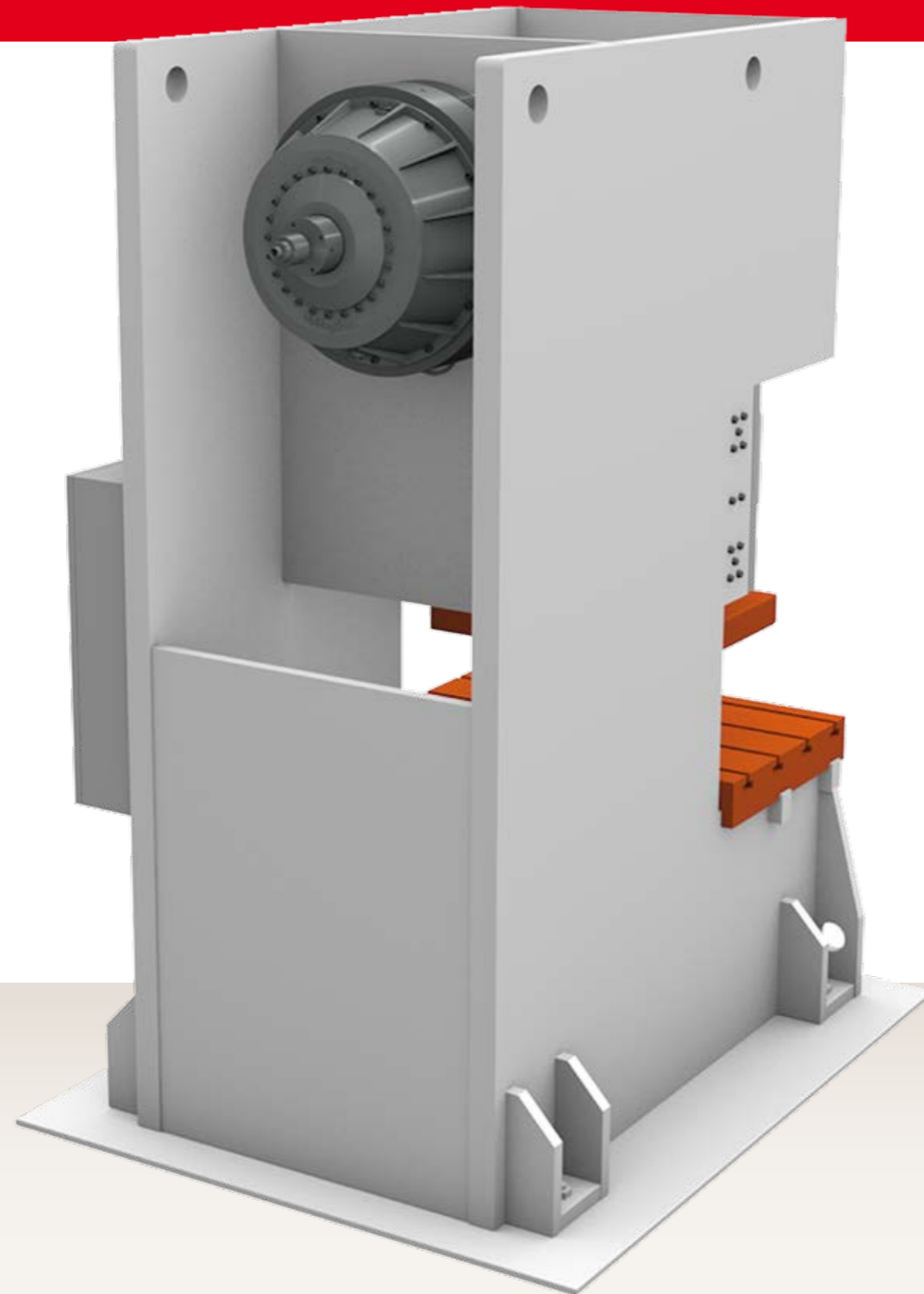

Easy assembly

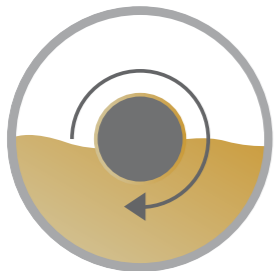

Wet-running



Design-to-cost

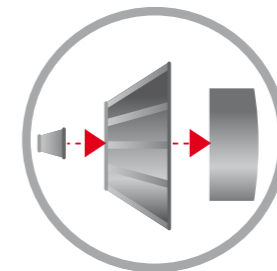

Systems approach

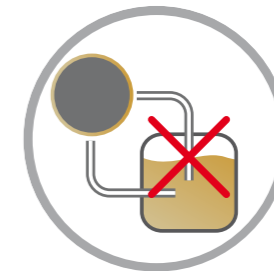

No external hydraulics



Ortlinghaus Quality



Advantages.

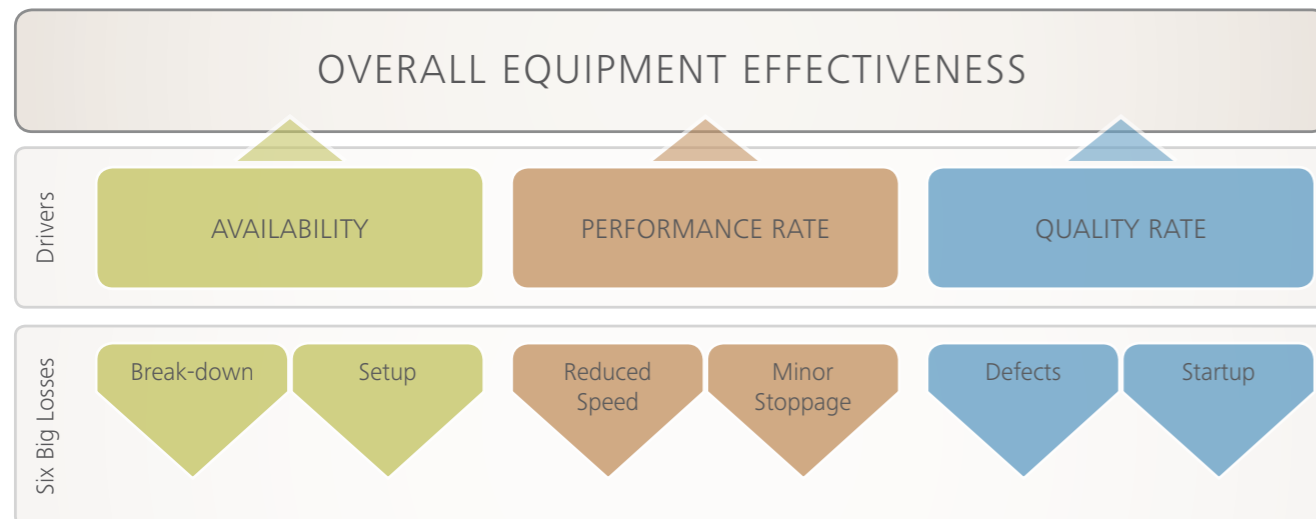

The Cee.go is a clutch/brake combination that can deliver significant improvement of the overall equipment effectiveness of a press.

It can be mounted very easily, reducing the effort needed for assembly.

Engineered as a complete system, it enables greater speed and therefore output through a reduced clutch activation time. In addition, the systems approach increases the durability of the product and reduces breakdowns.

With no external hydraulic system to be assembled, tested and integrated, set-up time during assembly is also reduced.

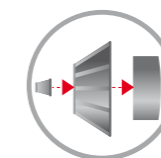

The Cee.go is a wet-running clutch/brake combination and therefore faster than dry-running clutch/brake combinations. Wet-running systems like the Cee.go are also low-wear. As a result, it produces far less defective output than a dry-running clutch with plates near the end of their useful life.

The design-to-cost approach allows us to offer a higher-quality product at the same price as comparable clutch/brake combinations. Higher quality in turn means fewer breakdowns or interruptions for adjustments during production.

The Ortlinghaus Quality is apparent. For more than 75 years we have delivered products that increase the up-time of presses, improve performance and enable our customers to produce presses which manufacture higher-quality products.



Ortlinghaus-Werke GmbH
Kenkhauser Str. 125
42929 Wermelskirchen
Germany

Phone: +49 (0)2196 85-0
Fax: +49 (0)2196 855-444

info@ortlinghaus.com
www.ortlinghaus.com