

Absolute encoders - SSI

Solid shaft with synchro flange

Single and multiturn encoders 13 bit ST / 12 bit MT (option: 16 bit MT)

AMG 71



AMG 71

Features

- Encoder multiturn / SSI
- Optical sensing method
- Resolution: singleturn 13 bit, multiturn 12 bit
- Multiturn sensing with microGen technologie, without gear or battery
- With additional incremental signals (SinCos 1 Vpp)

Optional

- Multiturn 16 bit

Technical data - electrical ratings

Voltage supply	7...30 VDC
Consumption w/o load	≤100 mA
Initializing time	≤200 ms after power on
Interface	SSI
Function	Multiturn
Steps per turn	8192 / 13 bit
Number of turns	4096 / 12 bit, 65536 / 16 bit (option)
Additional outputs	SinCos
Incremental output	2048 pulses (SinCos)
Bandwidth	200 kHz (-3 dB)
Difference of SinCos amplitude	≤20 mV
DC offset	≤20 mV
Sensing method	Optical
Code	Gray
Code sequence	CW
Inputs	SSI clock
Interference immunity	EN 61000-6-2
Emitted interference	EN 61000-6-3
Diagnostic functions	LED failure Self-diagnosis Code continuity check
Approvals	CE, UL approval / E256710

Technical data - mechanical design

Size (flange)	ø60 mm
Shaft type	ø6 mm solid shaft
Flange	Synchro flange
Protection DIN EN 60529	IP 66
Operating speed	≤5000 rpm (mechanical)
Operating torque typ.	2 Ncm
Rotor moment of inertia	25 gcm ²
Admitted shaft load	≤50 N axial ≤120 N radial
Materials	Housing: aluminium alloy Shaft: stainless steel
Operating temperature	-20...+85 °C
Resistance	IEC 60068-2-6 Vibration 10 g, 10-2000 Hz IEC 60068-2-27 Shock 100 g, 6 ms
Explosion protection	II 3 G Ex nA IIC T4 Gc X (gas) II 3 D Ex tc IIIC T85°C Dc X (dust)
Weight approx.	350 g
Connection	Terminal cover

Absolute encoders - SSI

Solid shaft with synchro flange

Single and multiturn encoders 13 bit ST / 12 bit MT (option: 16 bit MT)

AMG 71

Part number

AMG 71 **S** **S2048**

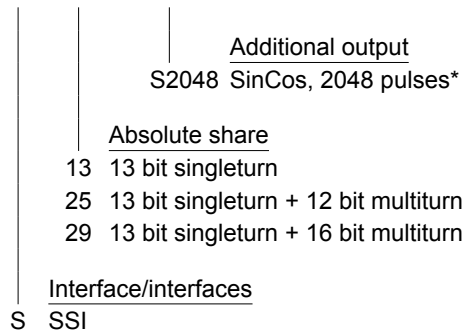

Accessories

Connectors and cables

HEK 8 Sensor cable for encoders

Mounting accessories

K 35 Spring washer coupling for solid shaft $\varnothing 6 \dots 12$ mm

Diagnostic accessories

HENQ 1100 Analyzer for encoders

Data transfer

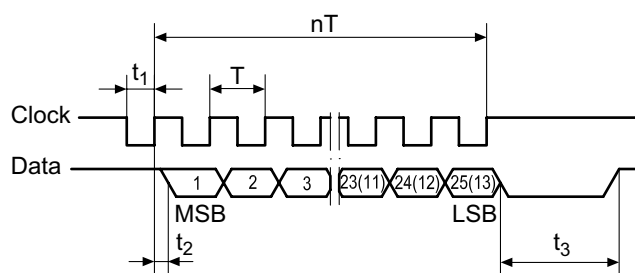

$T = 1.25 \dots 10 \mu\text{s}$

$t_1 = 0.63 \dots 5 \mu\text{s}$

$t_2 \leq 0.4 \mu\text{s}$

$t_3 = 12 \dots 30 \mu\text{s}$

$n =$ Number of bits

Clock frequency 100...800 kHz

Absolute encoders - SSI

Solid shaft with synchro flange

Single and multiturn encoders 13 bit ST / 12 bit MT (option: 16 bit MT)

AMG 71

Terminal significance

+UB	Voltage supply (for the encoder)
⊥	Ground (for the signals)
A	Cosinus
\bar{A}	Cosinus inv.
B	Sinus
\bar{B}	Sinus inv.
C	Clock
\bar{C}	Clock
D	Data
\bar{D}	Data

Terminal assignment

View A - Connecting terminal

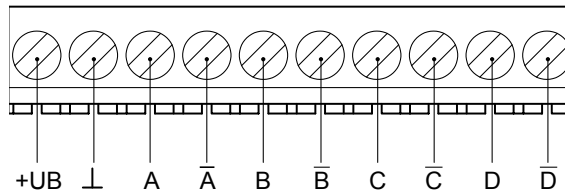

Dimensions

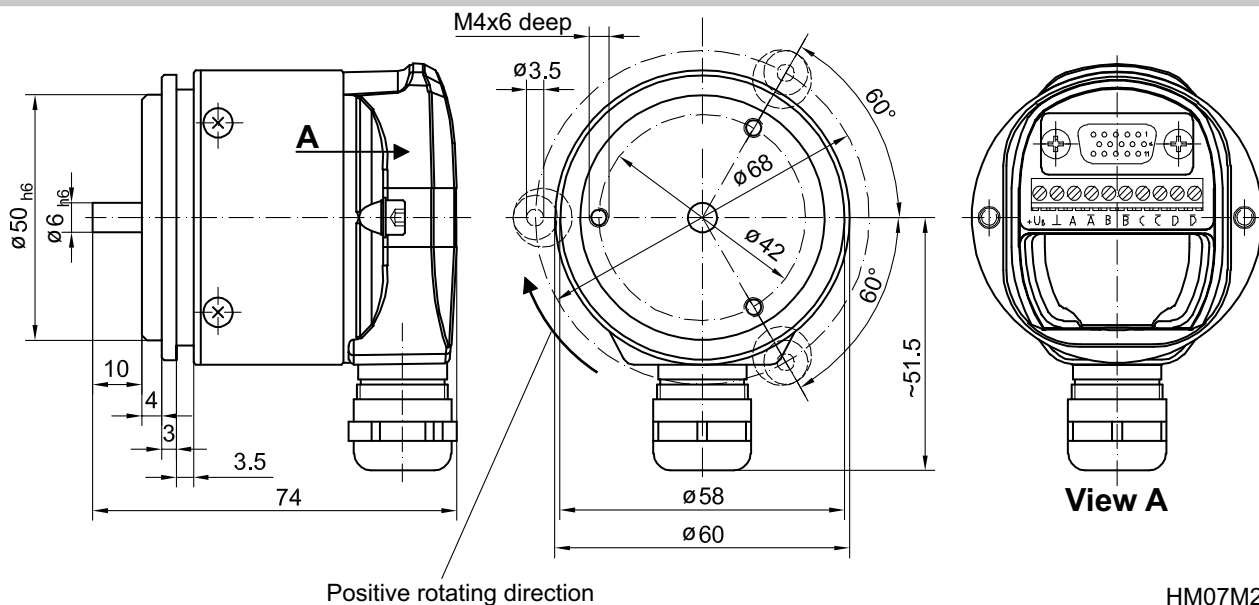

HM07M28048

Absolute encoders - SSI

Solid shaft with synchro flange

Single and multiturn encoders 13 bit ST / 12 bit MT (option: 16 bit MT)

AMG 71
