

# Absolute encoders - bus interfaces

Solid shaft with clamping or synchro flange

Magnetic single- or multiturn encoders 12 bit ST / 16 bit MT, DeviceNet

## BMSV 58, BMMV 58 DeviceNet - MAGRES



BMMV 58K DeviceNet with clamping flange

### Features

- Encoder single- or multiturn / DeviceNet
- Magnetic sensing
- Resolution: singleturn 12 bit, multiturn 16 bit
- Integrated fieldbus interface
- High resistance to shock and vibrations
- Resolution and zero point programmable
- Clamping or synchro flange

### Technical data - electrical ratings

Voltage supply	10...30 VDC
Consumption typ.	100 mA (24 VDC, w/o load)
Initializing time typ.	170 ms after power on
Interface	DeviceNet
Profile conformity	Device Profile Encoder V 1.0
Steps per turn	≤4096 / 12 bit
Absolute accuracy	±1 °
Sensing method	Magnetic
Code	Binary
Code sequence	CW default, programmable
Interference immunity	DIN EN 61000-6-2
Emitted interference	DIN EN 61000-6-3
Programmable parameters	Operating modes Total resolution Preset Scaling
Diagnostic functions	Position or parameter error Multiturn sensing
Approval	UL approval / E217823
<b>BMSV 58K, BMSV 58S</b>	
Function	Singleturn
<b>BMMV 58K, BMMV 58S</b>	
Function	Multiturn
Number of turns	≤65536 / 16 bit

### Technical data - mechanical design

Size (flange)	ø58 mm
Protection DIN EN 60529	IP 65
Operating speed	≤12000 rpm (mechanical) ≤6000 rpm (electric)
Operating torque typ.	0.023 Nm
Materials	Housing: aluminium Flange: aluminium
Operating temperature	-20...+85 °C
Relative humidity	95 %
Resistance	DIN EN 60068-2-6 Vibration 30 g, 10-2000 Hz DIN EN 60068-2-27 Shock 500 g, 6 ms
Weight approx.	300 g
Connection	Connector D-SUB, 9-pin
<b>BMSV 58K, BMMV 58K</b>	
Shaft type	ø10 mm solid shaft (clamping flange)
Flange	Clamping flange
Admitted shaft load	≤40 N axial ≤60 N radial
<b>BMSV 58S, BMMV 58S</b>	
Shaft type	ø6 mm solid shaft (synchro flange)
Flange	Synchro flange
Admitted shaft load	≤10 N axial ≤20 N radial

# Absolute encoders - bus interfaces

## Solid shaft with clamping or synchro flange

### Magnetic single- or multiturn encoders 12 bit ST / 16 bit MT, DeviceNet

#### BMSV 58, BMMV 58 DeviceNet - MAGRES

#### Part number

##### Singleturn clamping flange

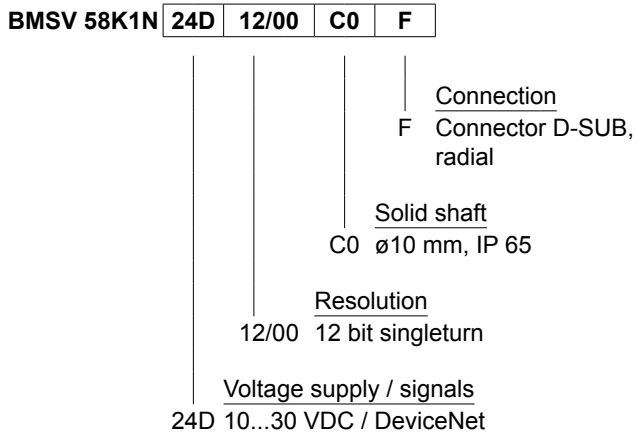

##### Multiturn clamping flange

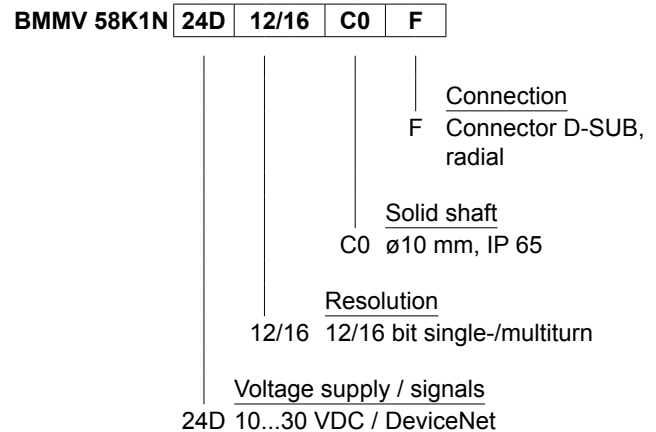

##### Singleturn synchro flange

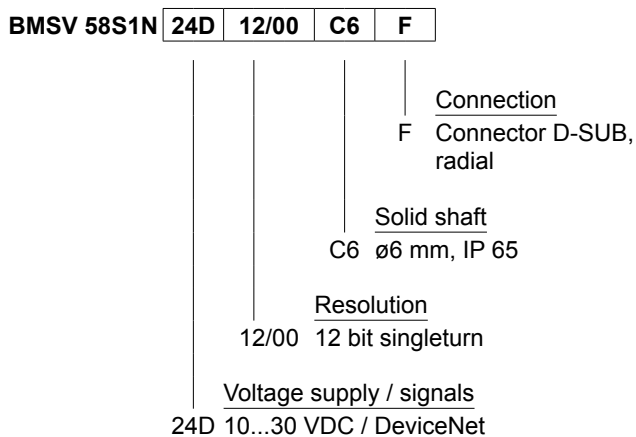

##### Multiturn synchro flange

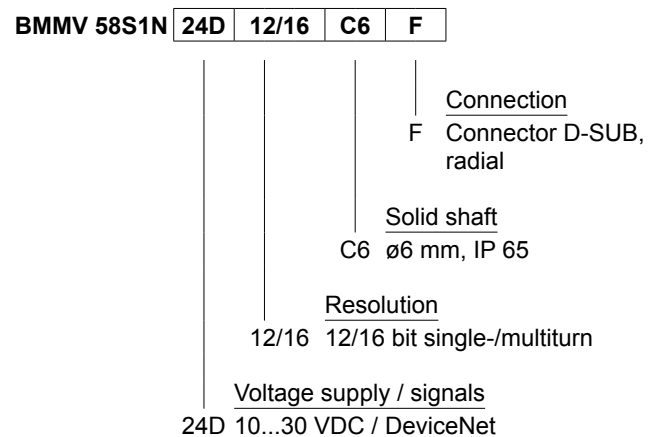

#### Accessories

##### Connectors and cables

10145023 Female connector D-SUB, 9-pin, angled

##### Mounting accessories for BMSV 58K, BMMV 58K

10252773 Clamp set ø15 mm

11053277 Bellows coupling aluminium/stainless steel 10 mm

##### Mounting accessories for BMSV 58S, BMMV 58S

10252773 Clamp set ø15 mm

##### Programming accessories

10147362 CD-ROM with GSD-/EDS-/XML files and user manuals

# Absolute encoders - bus interfaces

Solid shaft with clamping or synchro flange

Magnetic single- or multiturn encoders 12 bit ST / 16 bit MT, DeviceNet

## BMSV 58, BMMV 58 DeviceNet - MAGRES

Terminal significance	
+Vs	Encoder supply voltage.
0 V	Encoder ground connection relating to +Vs.
CAN_L	CAN bus signal (dominant Low).
CAN_H	CAN bus signal (dominant High).
CAN_GND	GND relating to CAN interface.

DeviceNet features	
Bus protocol	DeviceNet
Device profile	Device Profile for Encoders V 1.0
Operating modes	- I/O-Polling - Cyclic - Change of State
Preset	Parameter for setting the encoder to a requested position value assigned to a defined shaft position of the system. The offset of encoder zero point and mechanical zero point is stored in the encoder.
Rotating direction	Parameter for defining the rotating direction in which there have to be ascending or descending position values. Default setting: ascending position values when looking at the flange and rotating the shaft clockwise.
Scaling	Parameter defining the steps per turn as well as the total resolution.
Diagnosis	The encoder supports the following error warnings: - Position and parameter error - Lithium battery voltage control (Multiturn)
Default	125 kbit/s, Mac Id 63

Terminal assignment		
Connector D-Sub male		
Connector	Signals	Description
Pin 1	d.u.	do not use
Pin 2	CAN_L	Bus (dominant LOW)
Pin 3	CAN_GND	CAN Ground
Pin 4	d.u.	do not use
Pin 5	CAN_SHLD	CAN Shield
Pin 6	0 V	Supply voltage
Pin 7	CAN_H	Bus (dominant HIGH)
Pin 8	n.c.	-
Pin 9	+Vs	Supply voltage

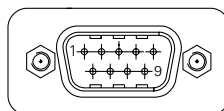

# Absolute encoders - bus interfaces

## Solid shaft with clamping or synchro flange

### Magnetic single- or multturn encoders 12 bit ST / 16 bit MT, DeviceNet

#### BMSV 58, BMMV 58 DeviceNet - MAGRES

#### Dimensions

BMSV/BMMV 58 DeviceNet clamping flange, D-SUB

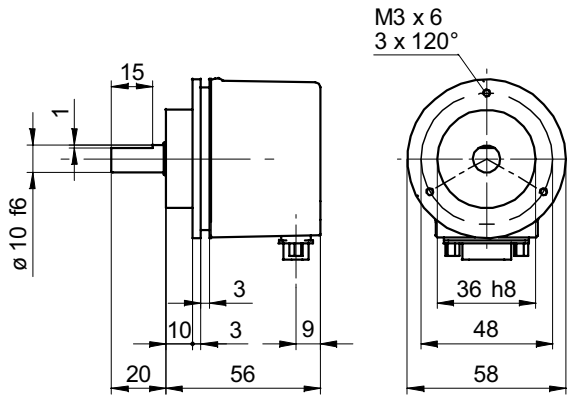

BMSV/BMMV 58 DeviceNet synchro flange, D-SUB

