

Accessories

Mounting accessories

Mounting kit 047



Features

- Universal torque arm for mounting hole circle 63...94 mm
- Flexible 30° alignment

Description

Torque support onto encoder by help of the attached screws. Push encoder onto the drive shaft and mount torque support onto the client side. Fastening clamping ring by the screw provided.

Part number

11113210 Torque arm, 1-arm, bolt circle $\varnothing 63...94$ mm, mounting M4 (mounting kit 047)

Scope of delivery

Included:
torque support, three screws M3 x 6 (DIN 7985 - TX10)

Suitable for

EIL580 - blind hollow shaft, EIL580 - through hollow shaft, EIL580P - blind hollow shaft, EIL580P - through hollow shaft

Dimensions

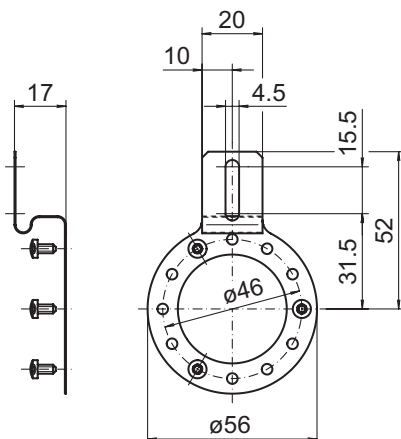

Z01645

Assembly drawing

