

Preset counters electromechanic

1 preset, subtracting, permanent precontact

Display 5 digits, manual/electric reset (zero)

FS309, FS319, FS329



FS309 - socket box



FS319 - front panel with screw mount



FS329 - front panel with spring clip mount

Features

- Preset counter with one preset
- Subtracting
- Display 5-digits
- Manual and electric reset

Technical data - electrical ratings

Voltage supply	24/110 VAC $\pm 10\%$ (50/60 Hz) 230 VAC $+6/-10\%$ (50/60 Hz) 24 VDC $\pm 10\%$
Residual ripple	<48 %
Nominal frequency	50 / 60 Hz
Pulse ratio	1:1
Service life	100 million impulses
Preset	1 preset
Output contact	Change-over contact by micro-switch, one-pole
Switching capacity	100 VA / 30 W
Limit switch lifetime	1 million switching cycles
Spark extinguisher	Recommended for inductive load
Precontact	Permanent precontact as permanent contact (please indicate desired value when ordering)
Standard DIN EN 61010-1	Protection class II Overvoltage category II Pollution degree 2
Emitted interference	DIN EN 61000-6-4
Interference immunity	DIN EN 61000-6-2

Preset counters electromechanic

1 preset, subtracting, permanent precontact

Display 5 digits, manual/electric reset (zero)

FS309, FS319, FS329

Technical data - mechanical design

Display	White numbers on black
Number of digits	5-digits
Digit height	4.5 mm
Count mode	1 impulse = 1 count
Step-by-step switching	Subtracting in 2 half steps
Measuring range	99 999
Zero setting	Manual by reset button and electric reset
Ambient temperature	0...+45 °C
Storage temperature	-20...+70 °C
Relative humidity	80 % non-condensing
Protection DIN EN 60529	IP 41
Connection	Soldering pins (flat)
Weight approx.	150 g
Material	Housing: Noryl PPO, black

FS309

Housing type	Socket box
Mounting	Socket box
Dimensions W x H x L	50 x 50 x 85.9 mm
Cutout dimensions	50 x 50 mm
Mounting depth	85.9 mm

FS319

Housing type	Built-in housing
Mounting	Front panel with 2 screws
Dimensions W x H x L	60 x 75 x 61 mm
Cutout dimensions	51 x 51 mm
Mounting depth	77.5 mm

FS329

Housing type	Built-in housing
Mounting	Front panel with spring clips
Dimensions W x H x L	53.2 x 53.2 x 61 mm
Cutout dimensions	51 x 51 mm
Mounting depth	77.5 mm

Connection diagram

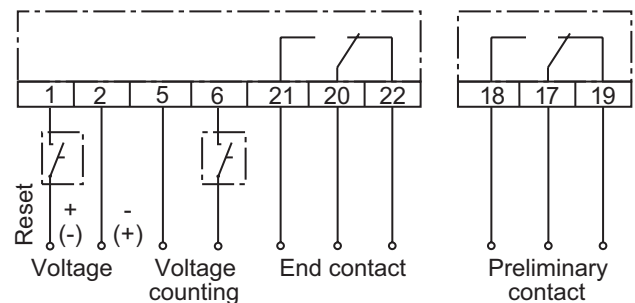

Trigger level

Count	Voltage DC	Voltage AC
Power	2.2 W	2.4 VA
Min. pulse duration	25 ms	50 ms
Min. pulse interval	25 ms	50 ms
Switch on time (at 25 °C)	100 %	100 %

Electronic reset	Voltage DC	Voltage AC
Power	22 W	25 VA
Min. pulse duration	250 ms	250 ms
Min. pulse interval	9x pulse duration	9x pulse duration
Switch on time (at 25 °C)	10 % max. 1 min	10 % max. 1 min

Accessories

Front frames for FS309

Z 102.01A	Front frame with knob lock provided on transparent cover
Z 102.02A	Front frame with cylinder lock provided on transparent cover
Z 107.02A	Front frame, insertion cutout 50 x 50 mm

Preset counters electromechanic

1 preset, subtracting, permanent precontact

Display 5 digits, manual/electric reset (zero)

FS309, FS319, FS329

Part number

Front panel with screw mount

FS309.

	<u>Precontact</u>
B	Without permanent precontact
K	With permanent precontact
	<u>Voltage</u>
A3	24 VDC
A5	24 VAC
A8	110 VAC
A9	230 VAC
	<u>Zero setting</u>
550A	With button reset and electric reset
551A	With button reset and electric reset, permanent precontact

Front panel with screw mount

FS319.

	<u>Precontact</u>
B	Without permanent precontact
K	With permanent precontact
	<u>Voltage</u>
A3	24 VDC
A5	24 VAC
A8	110 VAC
A9	230 VAC
	<u>Zero setting</u>
550A	With button reset and electric reset
551A	With button reset and electric reset, permanent precontact

Front panel with spring clips mount

FS329.

	<u>Precontact</u>
B	Without permanent precontact
K	With permanent precontact
	<u>Voltage</u>
A3	24 VDC
A5	24 VAC
A8	110 VAC
A9	230 VAC
	<u>Zero setting</u>
550A	With button reset and electric reset
551A	With button reset and electric reset, permanent precontact

Preset counters electromechanic

1 preset, subtracting, permanent precontact

Display 5 digits, manual/electric reset (zero)

FS309, FS319, FS329

Dimensions

FS309 - socket box

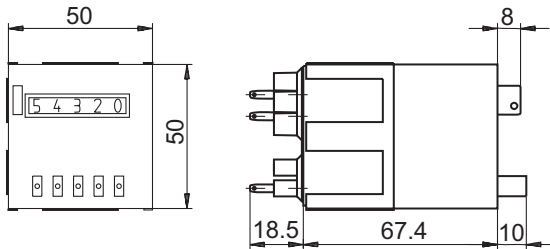

FS319 - front panel with 2 screws

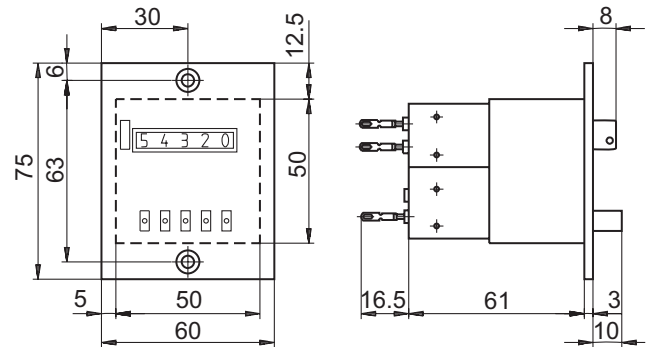

FS329 - front panel with spring clip mount

