

Accessories

Diagnostic accessories

Analyzer for encoders - HENQ 1100



Part number

HENQ 1100 Analyzer for encoders

Description

The Baumer Hübner ENcoder Quality Measurement System HENQ 1100 is a hand-held testing instrument for incremental encoders with HTL/TTL or sin/cos signal output.

Fast signal processing enables quick tracking of sporadic errors, for example caused by interference in the signal leads or short voltage drop-outs in power supply. In addition, both angular position and speed are continuously shown in the display.

Besides the Baumer encoders, also those of other brands with TTL/HTL or sin/cos signals can be utilized. Encoder supply is either by the HENQ 1100 or an external source. This way, the encoder allows for independent operation offline the standard supply and also eavesdropping on a running system.

Device operation is by the integrated, user-friendly keypad and a 4-line LCD display with backlight.

Measured values of several encoders can be compiled and saved in the memory for further evaluation.

User-defined profiles can be used to program various thresholds as parameters, for instance:

- permissible phase deviation
- permissible pulse/pause ratio

Besides visual error messages on the LCD display, the integrated buzzer will give an acoustic alarm. HENQ 1100 will come with a power pack (12 V power pack with integrated charging circuitry) as an option to enable mains-independent operation for up to 5 hours. Encoder supply by HENQ 1100 is also enabled when battery-powered.

Features

- Analyzer for encoders
- Continuous monitoring and display of encoder data (speed, angular position, position of the zero pulse, phase shift, pulse/pause ratio, voltage range etc.)
- Continuous error monitoring (elimination of signal disturbances, comparison of the nominal/actual number of pulses per turn, check of the quadrature coding)
- Individual error messages
- Windows applications software for the PC, for graphical display and statistical evaluation of the measurements
- Recording of measurements and error messages

Technical data

HENQ 1100

Voltage supply	9...30 VDC
Current consumption	≤500 mA
Permissible ambient temperature	-10...+50 °C
<u>Accumulator as option</u>	
Accumulator voltage	12 V nominal
Subthreshold warning	10 V
Charging time	5 hours
Operating time	~5 hours
Input	SUB-D female 15 pin
Outputs	SUB-D male 15 pin RS-485 (female 9 pin) Option: RS-232

Encoder

Output frequency	≤250 kHz
Encoder power supplied from the HENQ 1100	$U_1 = U_B - 1 \text{ V}$ or $U_2 = 5 \text{ V}$
Current consumption with encoder power supplied from the HENQ 1100 *	≤300 mA
External supply voltage with measuring signal looped through	$U_1 = U_{REG1}$ or $U_2 = U_{REG2}$
Current consumption with external supply voltage and encoder signal looped through *	≤500 mA

* limited by polymer fuse

Data display via measurement program for PC or Laptop (RS-485 interface):

- Display of
- Angular position
 - Zero pulse position
 - Speed
 - Voltage and current
 - Error messages

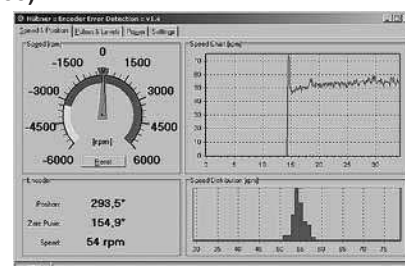

Accessories

Diagnostic accessories

Analyzer for encoders - HENQ 1100

Connection examples

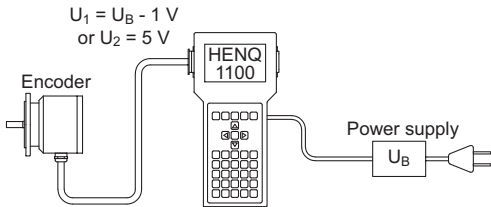

Encoder supply from the HENQ 1100

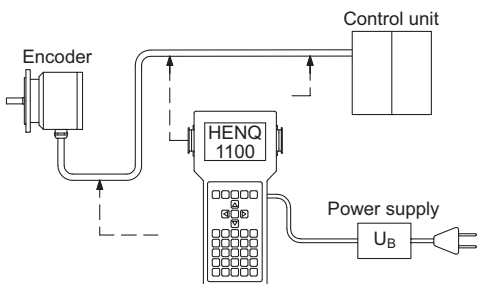

Error analysis through a step-by-step check of the test signal at various points in the signal path

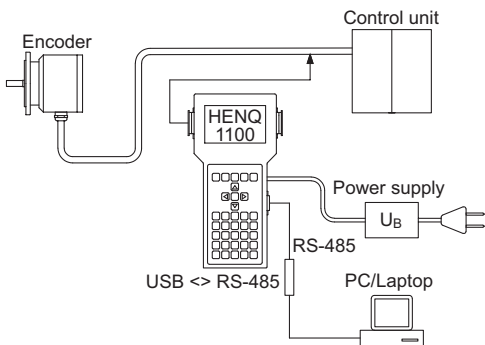

Long-term monitoring by a PC to detect sporadic errors

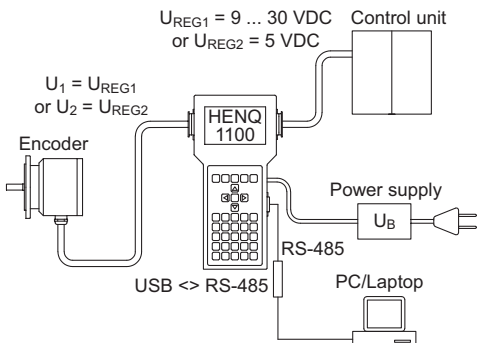

Long-term monitoring with simultaneous filtering of the looped-through measuring signal

Terminal assignment

Input/Output SUB-D

Female/male, 15 pin

	Input Assignment female	Output Assignment male
Pin 1	A+ (K1)	A+ (K1)
Pin 2	A- ($\overline{K1}$)	A- ($\overline{K1}$)
Pin 3	B+ (K2)	B+ (K2)
Pin 4	B- ($\overline{K2}$)	B- ($\overline{K2}$)
Pin 5	R+ (K0) [zero pulse]	R+ (K0) [zero pulse]
Pin 6	R- ($\overline{K0}$) [zero pulse inv.]	R- ($\overline{K0}$) [zero pulse inv.]
Pin 7	n.c.	n.c.
Pin 8	n.c.	n.c.
Pin 9	$U_1 = 9 \dots 30\text{ VDC}$	$U_{REG1} = 9 \dots 30\text{ VDC}^*$
Pin 10	$U_1 = 9 \dots 30\text{ VDC}$	$U_{REG1} = 9 \dots 30\text{ VDC}^*$
Pin 11	$U_2 = 5\text{ VDC}$	$U_{REG2} = 5\text{ VDC}^*$
Pin 12	$U_2 = 5\text{ VDC}$	$U_{REG2} = 5\text{ VDC}^*$
Pin 13	GND	GND
Pin 14	GND	GND
Pin 15	GND	GND

* from control unit

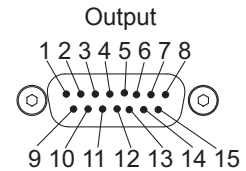
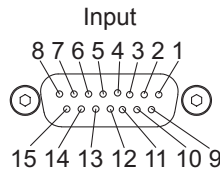

RS-485 interface

Assignment

Pin 1	B (D-)
Pin 2	A (D+)
Pin 3	B (D-)
Pin 8	A (D+)

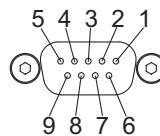

The output signals of the HENQ 1100 are always differential! It is not possible to make a daisy-chain signal loop with sinewave signals.