

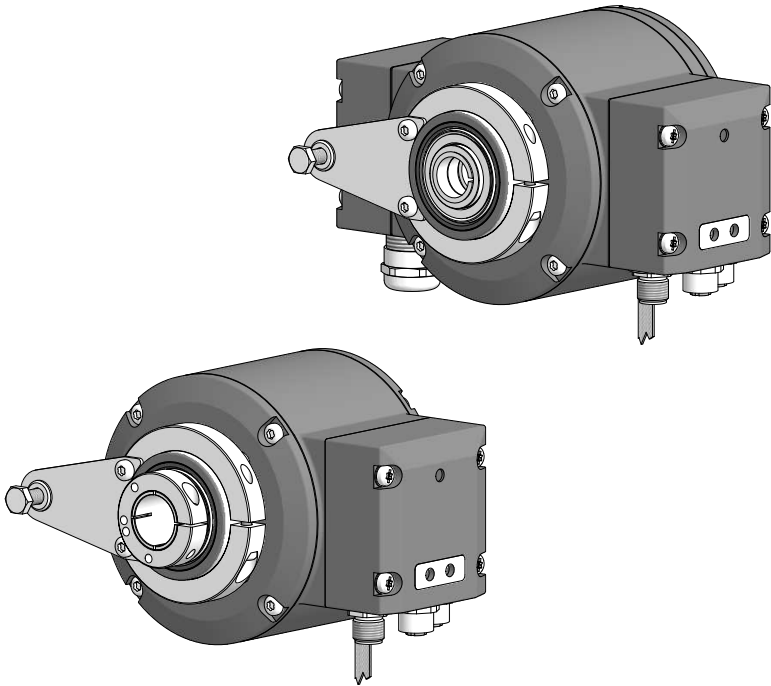

Installation and operating instructions



HMG 10 - PROFINET

Absolute Encoder with magnetic sensing

TABLE OF CONTENTS

1. IMPORTANT NOTES	1
1.1 Symbol guide	1
1.2 Intended use	1
1.3 Exclusion from liability	1
1.4 Maintenance and lifetime	2
1.5 Approvals and warranty	2
1.6 Storage temperature and disposal	2
2. SAFETY AND ATTENTION INSTRUCTIONS	3
2.1 Safety instructions	3
2.2 Attention instructions for mounting and operation	4
3. PREPARATION	5
3.1 Scope of delivery	5
3.2 Required accessory for mounting/dismounting (not included in scope of delivery)	6
3.3 Required tools (not included in scope of delivery)	6
4. MOUNTING	7
4.1 Positioning the torque plate	7
4.2 Mounting the torque arm at the encoder	7
4.3 Mounting to drive shaft	8
4.3.1 Version with blind hollow shaft	8
4.3.2 Version with cone shaft	9
4.3.3 Version with through hollow shaft	10
4.4 Drive side mounting of the torque arm	11
4.5 How to prevent measurement errors	12
5. ELECTRICAL CONNECTION	13
5.1 PROFINET	13
5.1.1 Features	13
5.1.2 Terminal assignment	14
5.1.2.1 Bus connecting box PROFINET [A]	14
5.1.2.2 Connector M12 [C] „Voltage supply“ (male, 4-pin, A-coded)	14
5.1.2.3 Connector M12 [D] and [E] „Data transmission“ (female, 4-pin, D-coded)	14

5.2	Speed switch and additional output incremental	15
5.2.1	Terminal significance	15
5.2.2	Output signals incremental (additional output)	15
5.2.3	LED function displays	16
5.2.4	Speed switch - Switching characteristics	16
5.2.5	Cable connection	17
5.2.6	Assignment connecting terminal	18
5.2.6.1	Connecting terminal terminal box [B] Speed switch without additional output	18
5.2.6.2	Connecting terminal terminal box [B] Speed switch with additional output	18
6.	DIMENSIONS	19
6.1	Blind hollow shaft	19
6.2	Through hollow shaft	20
6.3	Cone shaft	21
7.	DISMOUNTING	22
7.1	Version with blind hollow shaft or cone shaft	22
7.1.1	Step 1	22
7.1.2	Step 2	22
7.1.3	Step 3	23
7.1.4	Step 4	23
7.2	Version with through hollow shaft	24
8.	TECHNICAL DATA	25
8.1	Technical data - electrical ratings	25
8.2	Technical data - electrical ratings (speed switches)	25
8.3	Technical data - mechanical design	26

1. IMPORTANT NOTES

1.1 Symbol guide



Warning

Disregarding could result in serious injury, death or damage to property



Attention

Disregarding could result in damage to property or damage/malfunction of the encoder



Information

Additional information and recommendations

1.2 Intended use

The encoder is a precision measurement device for the acquisition of speed/position information for the control of drive units and the provision of electronic output signals for downstream devices.

The encoder must not be used for any other purpose. The function of the encoder is described in this mounting instruction. The customer must check the suitability for the purpose intended.

Mounting and selection must be executed by authorized and qualified personnel. Mounting, electrical commissioning or any other work with the encoder or system is to be performed by appropriately qualified staff only.

Do not put encoder into service if there is any visible evidence of damage.

Do not operate encoder beyond the limit values stated in this mounting instruction.

Any risk of personal injury, damage of the system or company equipment due to failure or malfunction of the encoder must be eliminated by corresponding safety measures.



Warning

Disregarding intended use could result in serious injury or damage to property.

1.3 Exclusion from liability

The manufacturer is not liable for any damage to persons or property resulting from unintended use of the encoder.

1.4 Maintenance and lifetime

The encoder may be only opened as described in this instruction. Repair or maintenance work that requires opening the encoder completely must be carried out by the manufacturer.

Alterations of the device are not permitted.

The expected operating life of the device depends on the ball bearings, which are equipped with a permanent lubrication.

In the event of queries or subsequent deliveries, the data on the device type label must be quoted, especially the type designation and the serial number.

1.5 Approvals and warranty

EU Declaration of Conformity meeting to the European Directives.

UL approval / E256710.

We grant a 2-year warranty in accordance with the regulations of the Central Association of the German Electrical Industry (ZVEI).

i warranty seal
Damaging the warranty seal on the encoder invalidates warranty.

1.6 Storage temperature and disposal

The storage temperature range of the encoder is between -15...+70 °C (caused by packing).

Encoder components are to be disposed of according to the regulations prevailing in the respective country.

2. SAFETY AND ATTENTION INSTRUCTIONS

2.1 Safety instructions



Explosion risk

Spark formation can cause a fire or an explosion.

- » Do not use the encoder in areas with explosive and/or highly inflammable materials. They may explode and/or catch fire by possible spark formation.



Risk of serious injuries due to rotating shafts

Hair and clothes may become tangled in rotating shafts. Touching the rotating parts can cause extremely serious injuries.

- » Before all work switch off all operating voltages and ensure machinery is stationary.
- » Prevent reconnection operating voltages by third parties.



Risk of serious injuries due to consequential damages

Plants can be deregulated due to malfunction or faulty signals of the encoder.

- » Damage caused by faulty operation or by a malfunction of the encoder must be eliminated by corresponding safety measures.







Risk of burns due to formation of heat

The encoder heats up at higher speed so there is a serious risk of burning shortly after the machine has been turned off.

- » Examine carefully whether the encoder overheats. Wear suitable gloves if necessary.

2.2 Attention instructions for mounting and operation

-  Risk of destruction due to electrostatic charge
Electronic parts contained in the encoder are sensitive to high voltages.
 - » Do not touch plug contacts or electronic components.
 - » Protect output terminals against external voltages.
 - » Do not exceed max. operating voltage.
-  Risk of destruction due to mechanical overload
Rigid mounting may give rise to constraining forces.
 - » Never restrict the freedom of movement of the encoder. The installation instructions must be followed.
 - » It is essential that the specified clearances and/or angles are observed.
-  Risk of destruction due to mechanical shock
Violent shocks, e. g. due to hammer impacts, can lead to the destruction of the sensing system.
 - » Never use force. Assembly is simple when correct procedure is followed.
 - » Use suitable puller for disassembly.
-  Risk of destruction due to contamination
Dirt penetrating inside the encoder can cause short circuits and damage the optical sensing system.
 - » Absolute cleanliness must be maintained when carrying out any work on the open terminal box.
 - » When dismantling, never allow lubricants to penetrate the encoder.
-  Risk of destruction due to adhesive fluids
Adhesive fluids can damage the optical sensing system and the bearings. Dismounting an encoder, secured to a shaft by adhesive may lead to the destruction of the unit.
 - » Do not use adhesive fluids for fixing.

3. PREPARATION

3.1 Scope of delivery

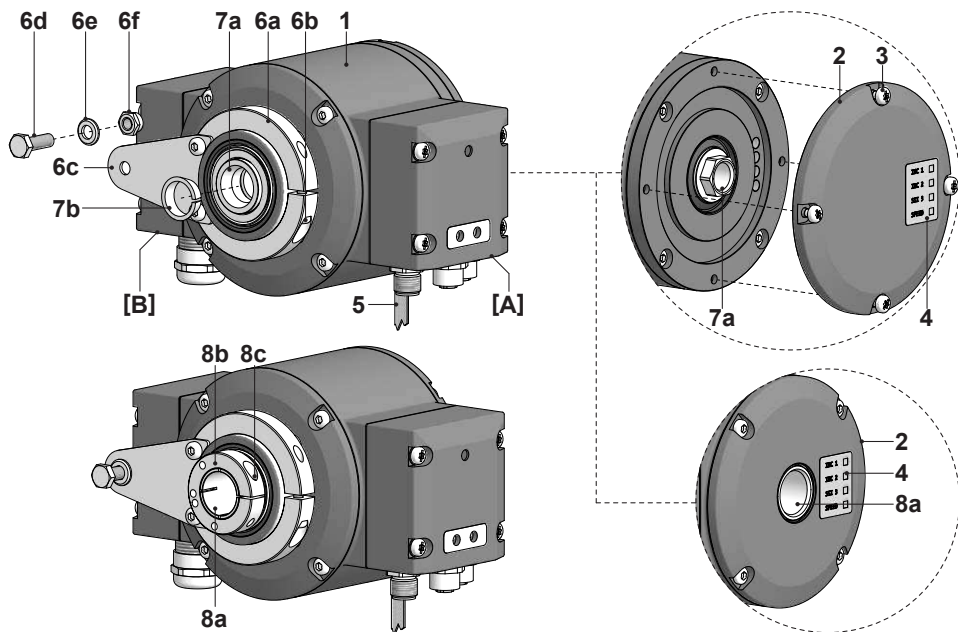

- 1 Housing
 - 2 Cover
 - 3 Torx and slotted screw - DIN 7964, M4x10 mm
 - 4 LED function indicators
 - 5 Earthing strap, length ~230 mm
- Equipment for mounting a torque arm:
- 6a Clamping ring adjustable through 360°
 - 6b Torx and slotted screw - ISO 7045, M4x20 mm
 - 6c Torque plate
 - 6d Hexagon screw - ISO 4017, M6x18 mm
 - 6e Washer - ISO 7090, B6.4
 - 6f Self-locking nut - ISO 10511, M6

Blind hollow shaft* or cone shaft*:

- 7a Blind hollow shaft or cone shaft with spanner flat 17 a/f
- 7b Clamping element, not for cone shaft

Through hollow shaft*:

- 8a Through hollow shaft
- 8b Clamping ring
- 8c Torx screw - ISO 7045, M3x12 mm

Radial terminal boxes* (see section 5):

- [A] Bus connecting box PROFINET
- [B] Speed switch + additional output

* Depending on version

3.2 Required accessory for mounting/dismounting (not included in scope of delivery)

i Connecting cables and respective connectors are required for the electrical connection. Details see *section 5, page 13*.

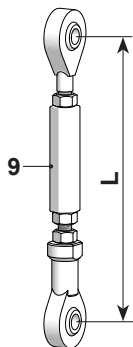

Torque arm, length L / order number

- 9** Standard version:
67-70 mm / 11043628
125 (±5) mm, can be shortened to ≥71 mm / 11004078
440 (+20/-15) mm, can be shortened to ≥131 mm / 11002915
- 9** Insulated version:
67-70 mm / 11054917
125 (±5) mm, can be shortened to ≥71 mm / 11072795
440 (+20/-15) mm, can be shortened to ≥131 mm / 11082677

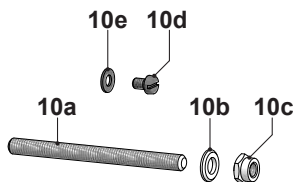

Mounting kit, order number 11077197:

- 10a** Thread rod - M6, length variable ≤210 mm
- 10b** Washer - ISO 7090, B6.4
- 10c** Self-locking nut - ISO 10511, M6
- 10d** Cylinder screw for earthing strap - ISO 1207, M6x8
- 10e** Washer for earthing strap - ISO 7090, B6.4

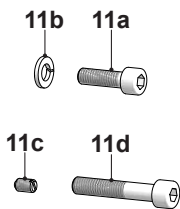

Mounting/dismounting kit, order number 11077087:

(Not required for version with through hollow shaft)

- 11a** Cylinder screw - ISO 4762, M6x30
- 11b** Spring washer - DIN 7980, 6
- 11c** Setscrew - ISO 7436, M6x10
- 11d** Cylinder screw - ISO 4762, M8x45

3.3 Required tools (not included in scope of delivery)

- 3, 5 and 6 mm
- 1.6x8.0 mm and 0.8x4 mm
- 10 (2x), 17 and 22 mm
- ★ TX 10, TX 20

4. MOUNTING

4.1 Positioning the torque plate

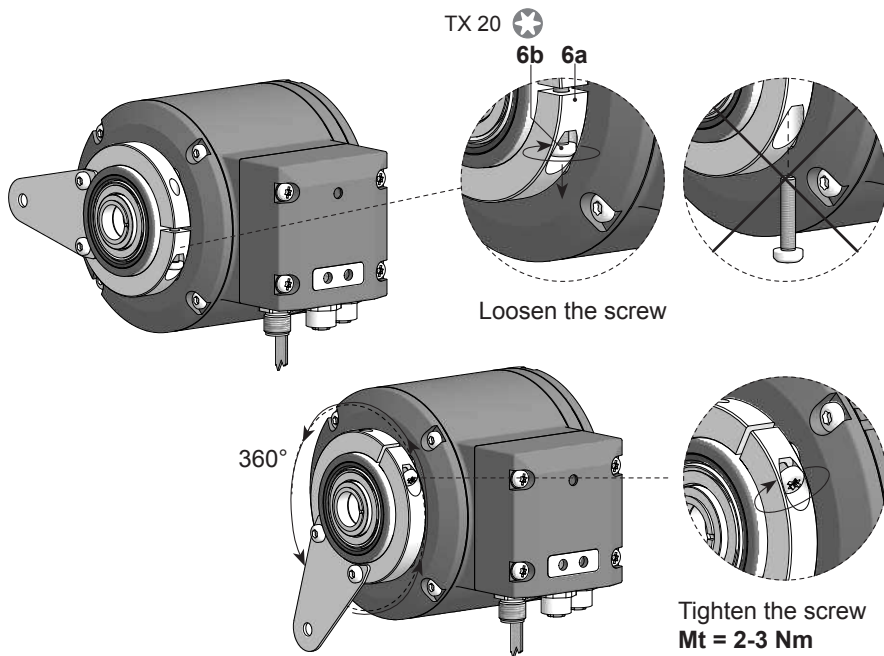

4.2 Mounting the torque arm at the encoder

» Note the mounting instructions for the torque arm in *section 4.4, page 11.*

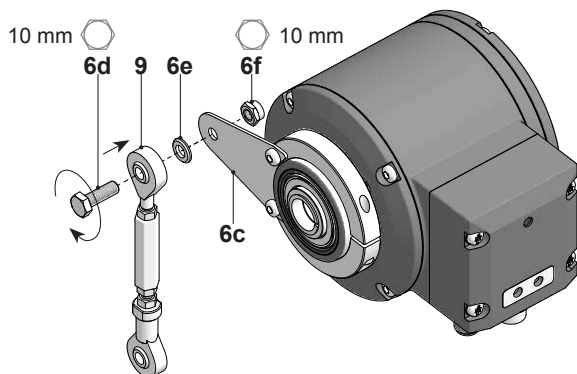

4.3 Mounting to drive shaft

4.3.1 Version with blind hollow shaft

- ☞ **Lifetime restrictions and angle error by radial deviations**
High runout of the drive shaft can cause encoder angle error, see *section 4.5, page 12*.
High runout of the drive shaft can cause vibrations, which can shorten the lifetime of the encoder.
- » Lubricate drive shaft!
- ☞ Minimize drive shaft runout (≤ 0.2 mm; ≤ 0.03 mm recommended).

ød (mm)	L1 (mm)	L2 (mm)
16 _{h6}	53	52 (40-52)
20 _{h6}	35	34 (25-34)

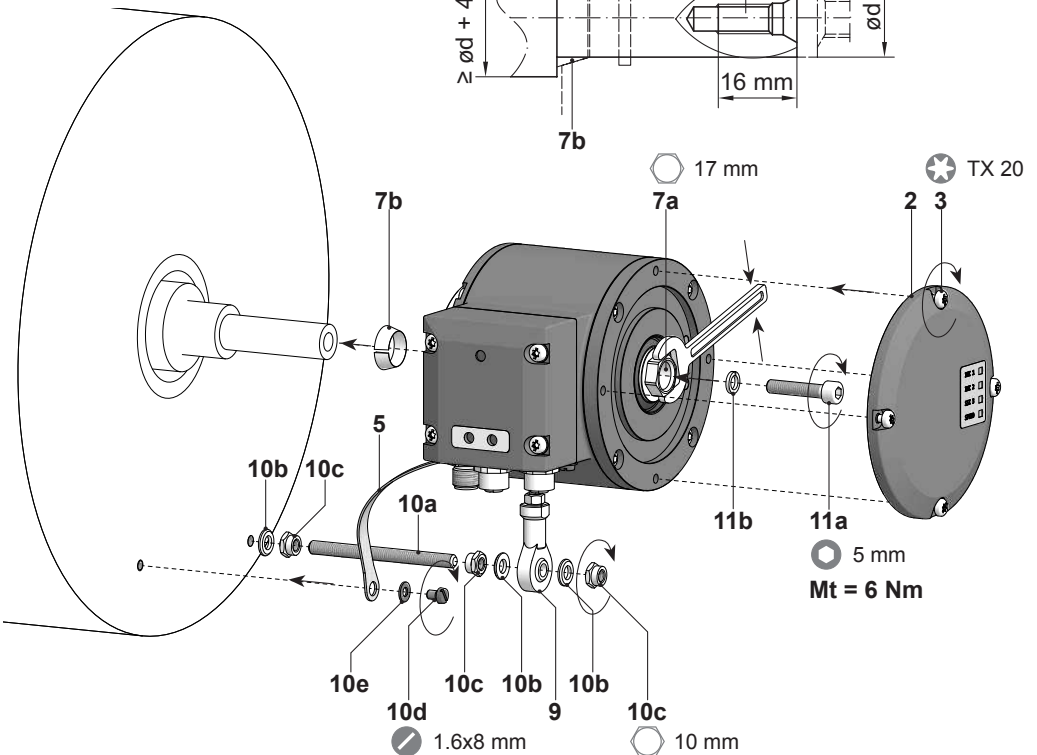
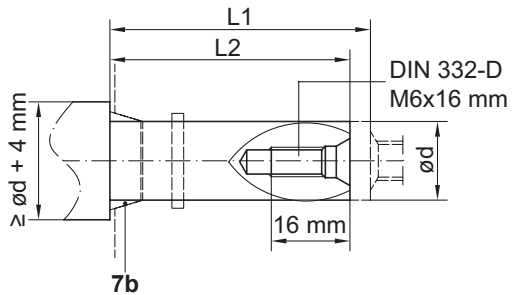

- i** The encoder must be mounted with cable connection facing downward and not exposed to water.

4.3.2 Version with cone shaft

- ☞ Lifetime restrictions and angle error by radial deviations
High runout of the drive shaft can cause encoder angle error, see *section 4.5, page 12*.
High runout of the drive shaft can cause vibrations, which can shorten the lifetime of the encoder.
- » Lubricate drive shaft!
- ☞ Minimize drive shaft runout (≤ 0.2 mm; ≤ 0.03 mm recommended).

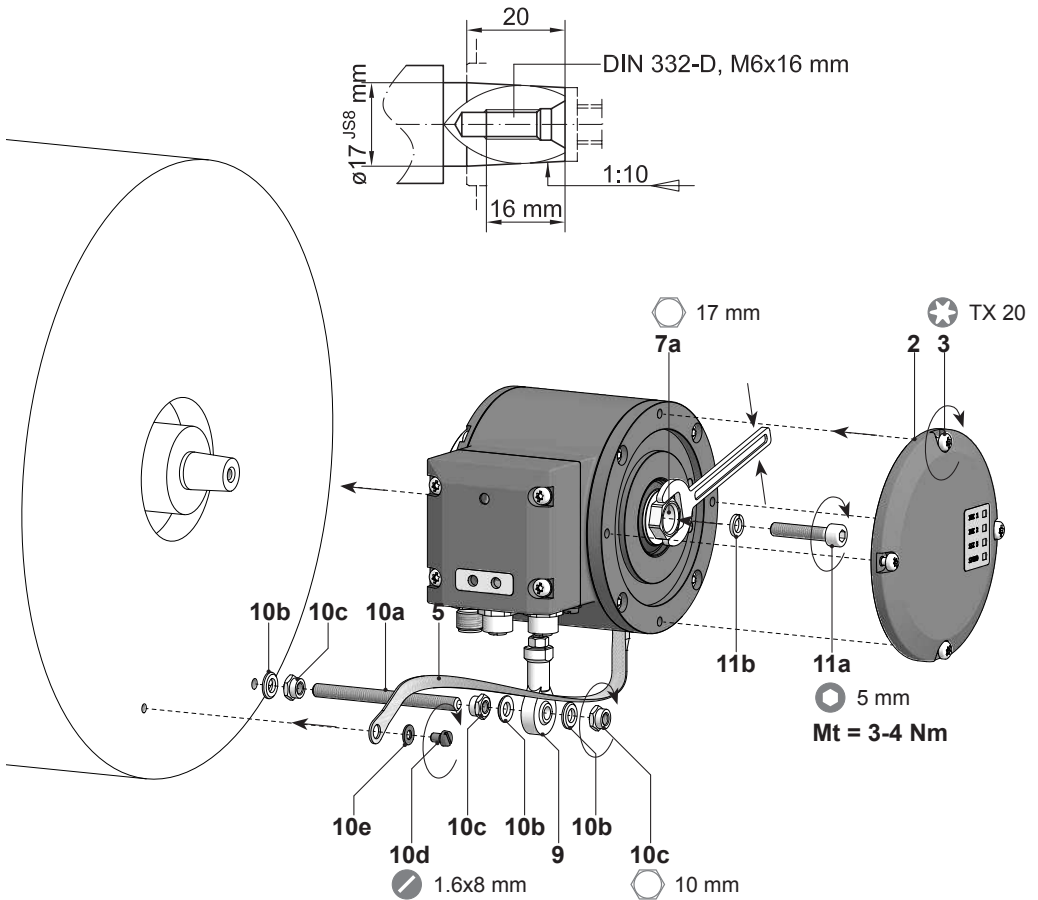

i The encoder must be mounted with cable connection facing downward and not exposed to water.

4.3.3 Version with through hollow shaft

- ☞ Lifetime restrictions and angle error by radial deviations
High runout of the drive shaft can cause encoder angle error, see *section 4.5, page 12*.
High runout of the drive shaft can cause vibrations, which can shorten the lifetime of the encoder.
- » Lubricate drive shaft!
- ☞ Minimize drive shaft runout (≤ 0.2 mm; ≤ 0.03 mm recommended).

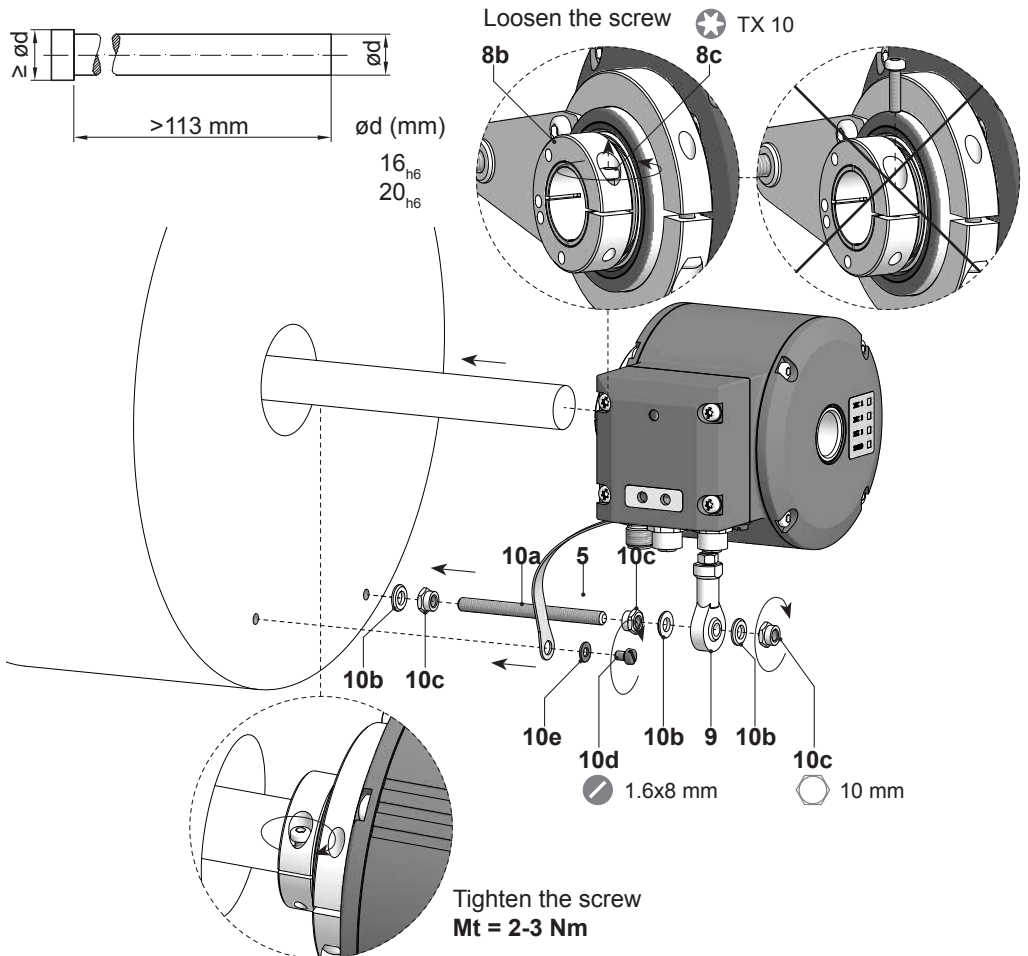

- i* The encoder must be mounted with cable connection facing downward and not exposed to water.

4.4 Drive side mounting of the torque arm



Lifetime restrictions and angle error of the encoder

A play of just ± 0.03 mm, results in concentricity error of the encoder of 0.06 mm. That may lead to a large angle error, see *section 4.5, page 12*.

» Mount the torque arm without play.

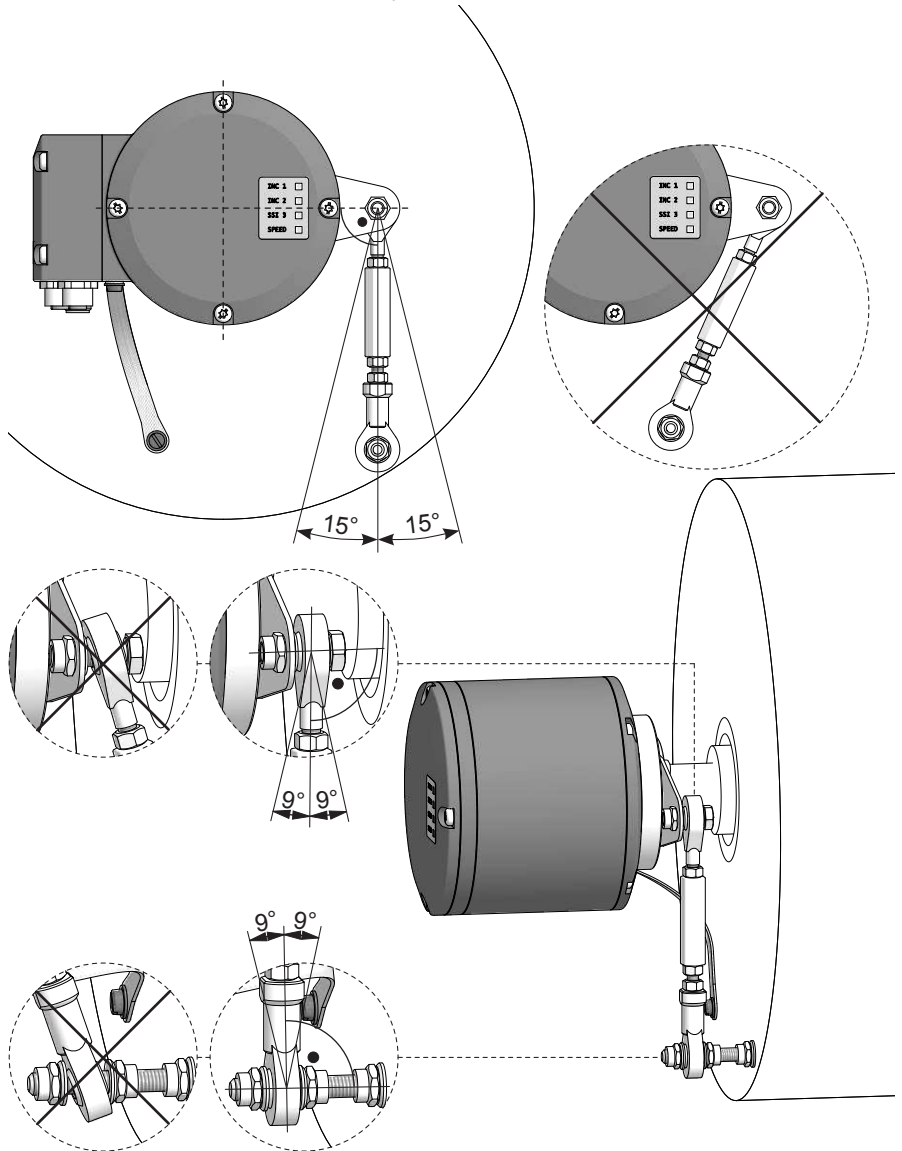

4.5 How to prevent measurement errors

To ensure that the encoder operates correctly, it is necessary to mount it accurately as described in section 4.1 to 4.4, which includes correct mounting of the torque arm.

The radial runout of the drive shaft should not exceed 0.2 mm (0.03 mm recommended), to prevent an angle error.

An angle error may be reduced by increasing the length of L1*. Make sure that the length L2 of the torque arm, see below, is at least equal to L1**.

The angle error $\Delta\rho_{\text{mech}}$ can be calculated as follows:

$$\Delta\rho_{\text{mech}} = \pm 90^\circ / \pi \cdot R / L1$$

with R: Radial runout in mm

L1: Distance of the torque arm to the center point of the encoder in mm

Example:

For R = 0.06 mm and L1 = 69.5 mm the resulting angle error $\Delta\rho_{\text{mech}}$ equals $\pm 0.025^\circ$.

i For more information, call the telephone hotline at +49 (0)30 69003-111.

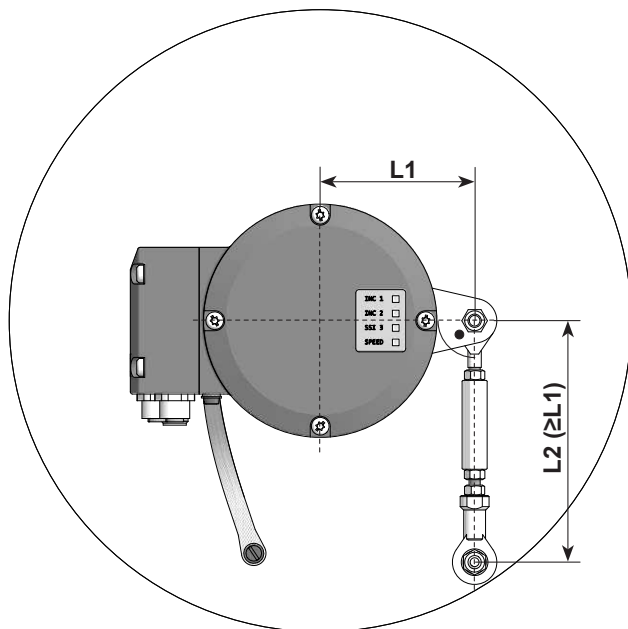

* For this different braces for the torque arm are available on request.

** If $L2 < L1$, L2 must be used in the calculation formula.

5. ELECTRICAL CONNECTION

5.1 PROFINET

i Please find a detailed instruction for the PROFINET interface and the device description file in the manual on the CD provided with the device.

5.1.1 Features

Bus protocol	PROFINET
Device profile	Encoder profile PNO 3.162
Features	100 MBaud Fast Ethernet IP address programmable Realtime (RT) Class 1, IRT Class 2, IRT Class 3
Process data	Position value 32 bit input data



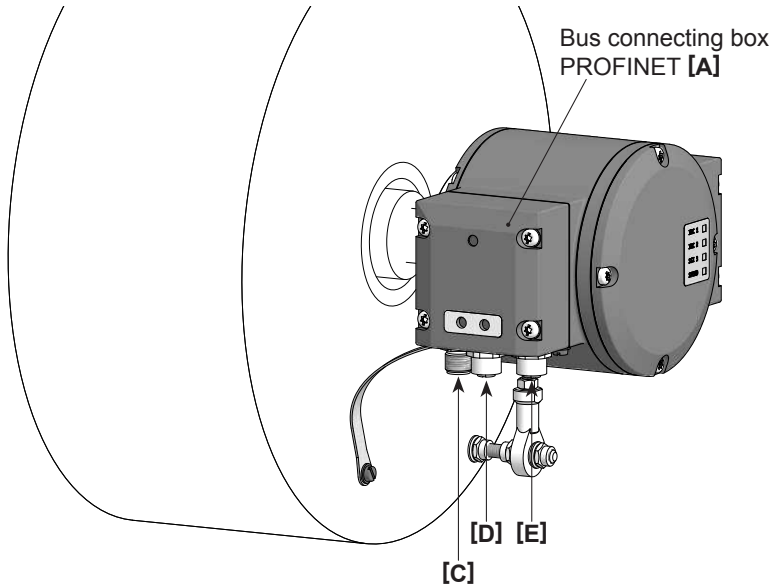

5.1.2 Terminal assignment

-  Use connecting cable and connector exclusively in accordance to the PROFINET directive.





5.1.2.1 Bus connecting box PROFINET [A]



5.1.2.2 Connector M12 [C] „Voltage supply“ (male, 4-pin, A-coded)

	MALE	CONNECTION	DESCRIPTION
	1	UB	Voltage supply 10...30 VDC
	2	-	Do not use
	3	GND	Ground for UB
	4	-	Do not use

5.1.2.3 Connector M12 [D] and [E] „Data transmission“ (female, 4-pin, D-coded)

	FEMALE	CONNECTION	DESCRIPTION
	1	TxD+	Transmission data+
	2	RxD+	Receiving data+
	3	TxD-	Transmission data-
	4	RxD-	Receiving data-

5.2 Speed switch and additional output incremental

5.2.1 Terminal significance

+UB	Voltage supply
⊥	Ground
A+	Channel A+
A-	Channel A- (Channel A+ inverted)
B+	Channel B+
B-	Channel B- (Channel B+ inverted)
R+	Zero pulse (reference signal)
R-	Zero pulse inverted
nE+	System OK+ / error output
nE-	System OK- / error output inverted
SP+*	DSL_OUT1 / speed switch (Open-Collector** or Solid State Relay**)
SP-*	DSL_OUT2 / speed switch (0 V** or Solid State Relay**)
SA*	RS485+ / programming interface
SB*	RS485- / programming interface
dnu	Do not use

* Only at version with speed switch

** Depending on version

5.2.2 Output signals incremental (additional output)

At positive rotating direction

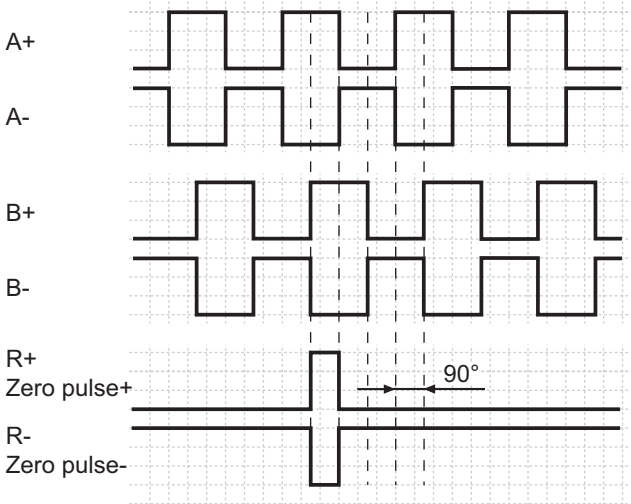

5.2.3 LED function displays

LED	red	green
INC1	Without function	Without function
INC2 (additional output incremental)	Undervoltage Overload Over-temperature	OK
Status	Internal error	OK
Speed	Speed higher switching speed (overspeed)	Speed lower switching speed

5.2.4 Speed switch - Switching characteristics

Event	State of the speed switch output
During initialisation	High resistance (overspeed)
After initialisation and speed $\leq -n_s$ (off)	High resistance (overspeed)
$-n_s$ (off) < speed $\leq -n_s$ (on)	State unchanged Low resistance (no overspeed) after initialisation if the encoder is rotating between the switching range during initialisation.
$-n_s$ (on) < speed < $+n_s$ (on)	Low resistance (no overspeed)
$+n_s$ (on) \leq speed < $+n_s$ (off)	State unchanged Low resistance (no overspeed) after initialisation if the encoder is rotating between the switching range during initialisation.
$+n_s$ (off) \leq speed	High resistance (overspeed)

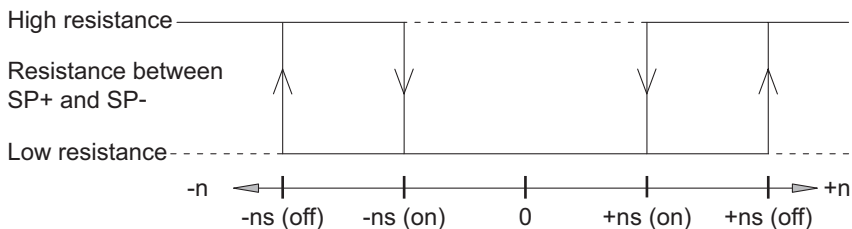

n = Speed

$+n_s$ (on) = Activation speed at shaft rotation in positive rotating direction*

$+n_s$ (off) = Deactivation speed at shaft rotation in positive rotating direction*

$-n_s$ (on) = Activation speed at shaft rotation in negative rotating direction*

$-n_s$ (off) = Deactivation at shaft rotation in negative rotating direction*

* See section 6, page 19

5.2.5 Cable connection

 To ensure the specified protection of the device the correct cable diameter must be used.

Connecting cables are not in scope of delivery.

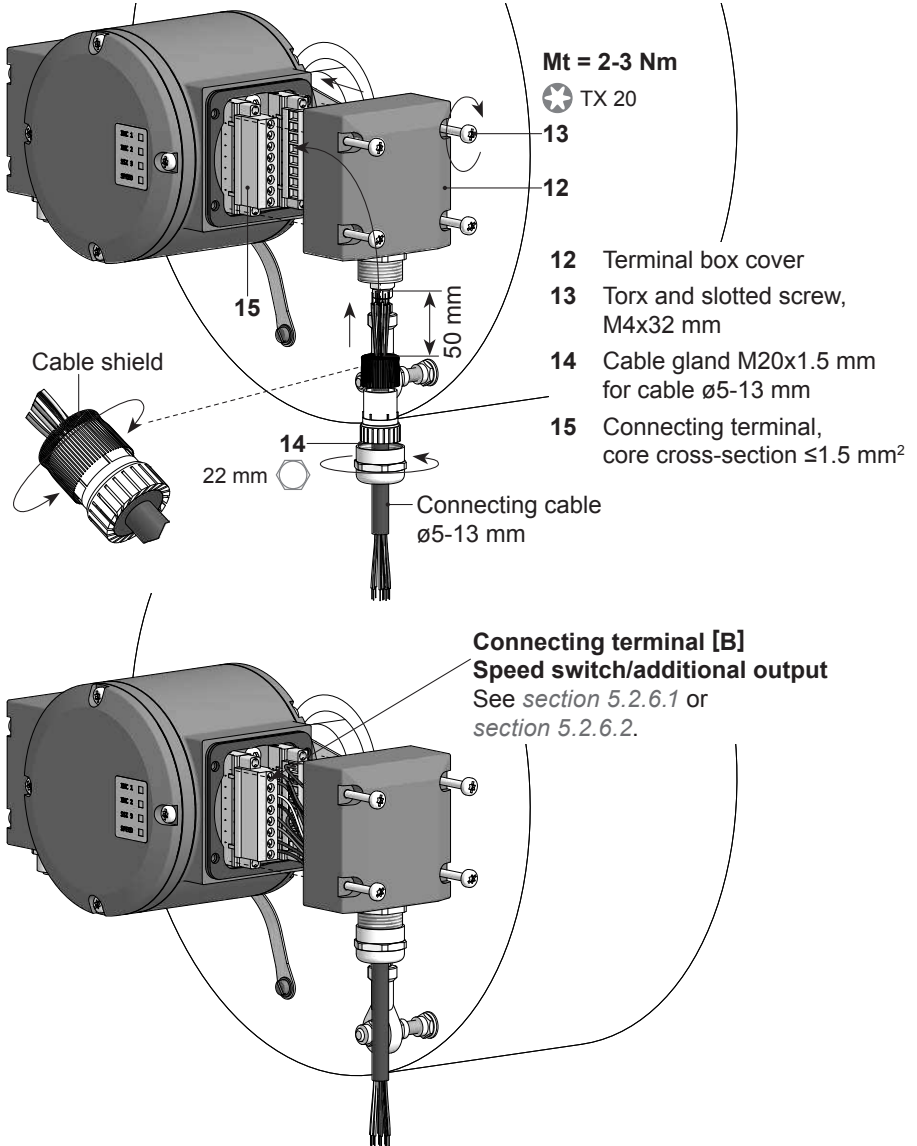

5.2.6 Assignment connecting terminal

-  Do not connect voltage supply to outputs! Danger of damage!
Please, beware of possible voltage drop in long cable leads (inputs and outputs)!

5.2.6.1 Connecting terminal terminal box [B] Speed switch without additional output

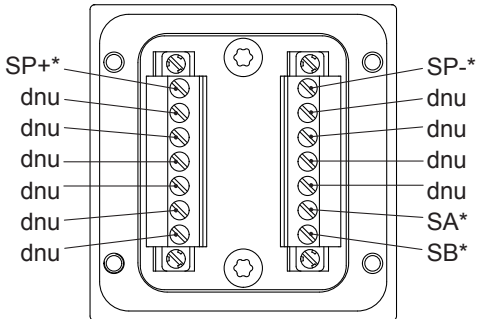

5.2.6.2 Connecting terminal terminal box [B] Speed switch with additional output

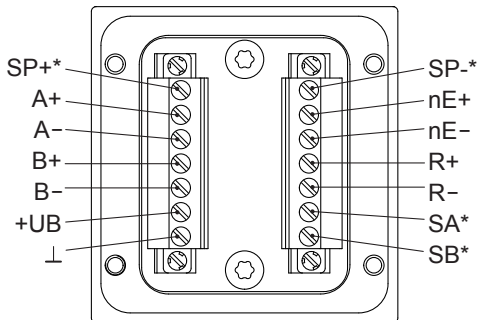

* Only at version with speed switch

7. DISMOUNTING

7.1 Version with blind hollow shaft or cone shaft

Pictures showing the version with blind hollow shaft. The dismounting steps be identical at the version with cone shaft.

7.1.1 Step 1

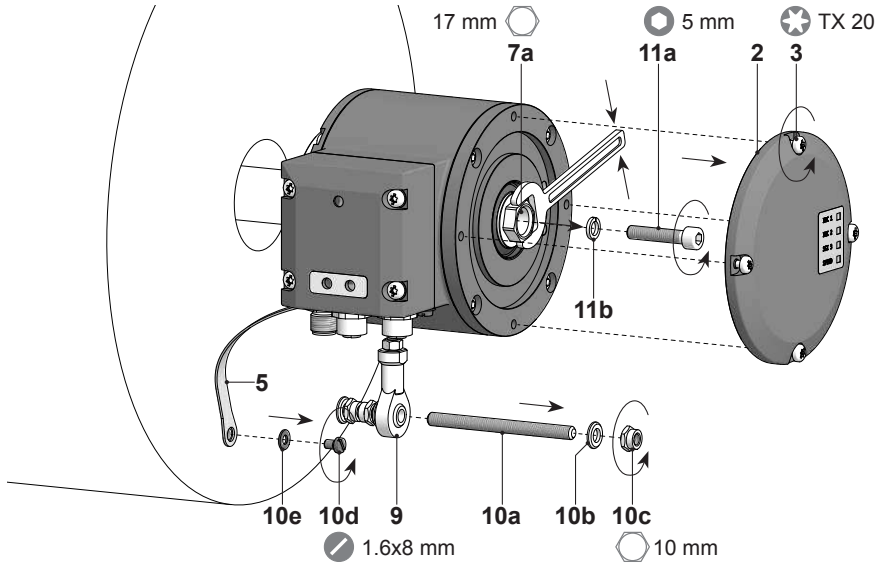

7.1.2 Step 2

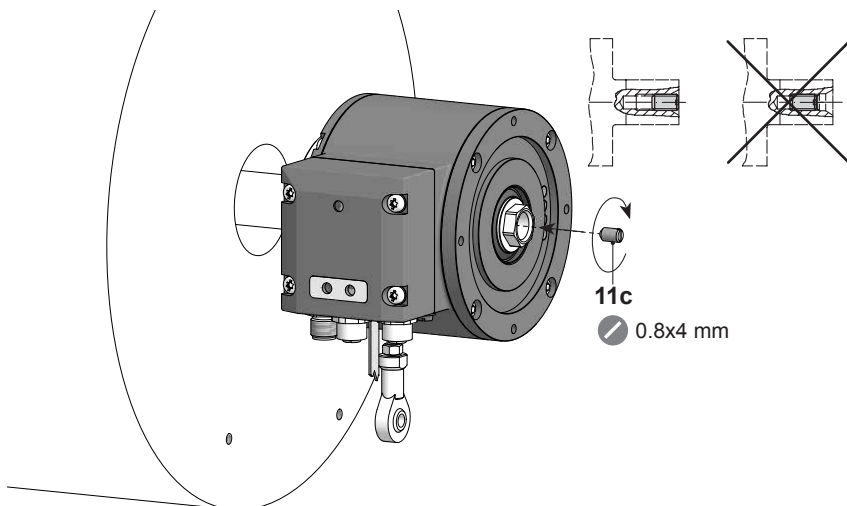

7.1.3 Step 3

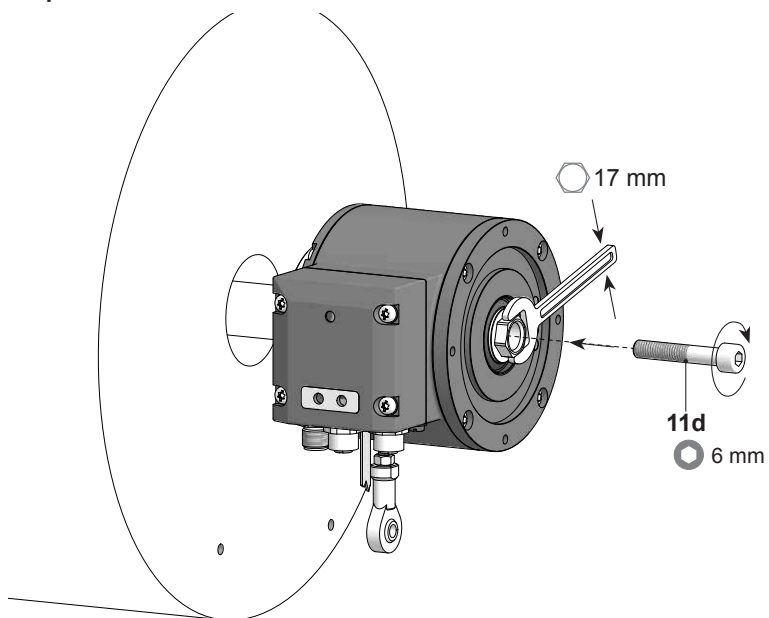

7.1.4 Step 4

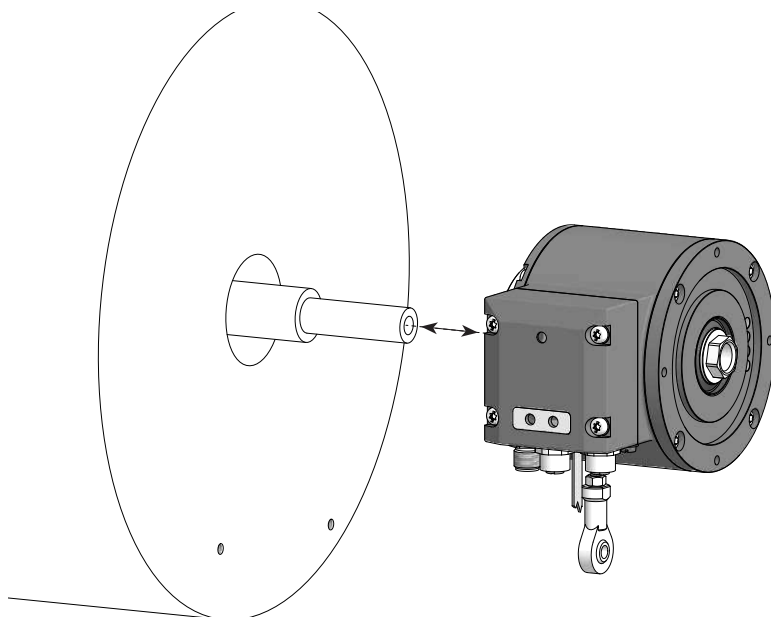

7.2 Version with through hollow shaft

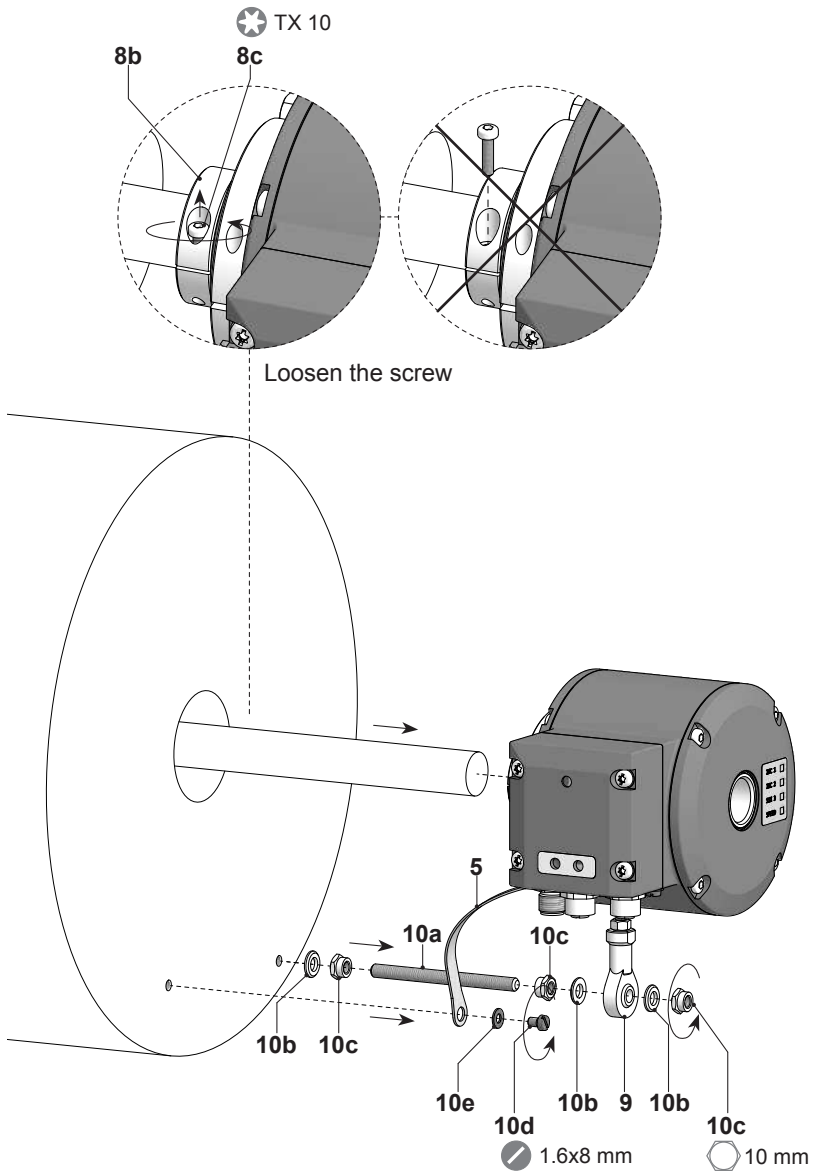

8. TECHNICAL DATA

8.1 Technical data - electrical ratings

Voltage supply	10...30 VDC
Short-circuit proof	Yes
Consumption w/o load	≤200 mA
Initializing time	≤500 ms after power on
Interface	PROFINET
Function	Multiturn
Transmission rate	100 MBaud
Device address	Automatic address designation
Steps per turn	8192 / 13 bit
Number of turns	65536 / 16 bit
Additional outputs	Square-wave HTL Square-wave TTL (RS422)
Sensing method	Magnetic
Interference immunity	EN 61000-6-2
Emitted interference	EN 61000-6-3
Programmable parameters	Steps per revolution Number of revolutions Preset, scaling, rotating direction
Diagnostic function	Position or parameter error
Status indicator	DUO-LED und LEDs link/activity in bus connecting box 4 LEDs in device back side
Approvals	CE, UL approval / E256710

8.2 Technical data - electrical ratings (speed switches)

Interface	RS485
Switching accuracy	±2 % (or Digit)
Switching outputs	1 output (Open-Collector* or Solid State Relay*)
Output switching capacity	30 VDC; ≤100 mA
Switching delay time	≤20 ms

* Depending on version

8.3 Technical data - mechanical design

Size (flange)	ø105 mm
Flange	Support plate, 360° freely positionable
Protection DIN EN 60529	IP 66/IP 67
Operating speed	≤6000 rpm
Range of switching speed	±2...6000 rpm, default 6000 rpm
Operating torque typ.	10 Ncm
Rotor moment of inertia	950 gcm ²
Admitted shaft load	≤450 N axial ≤650 N radial
Materials	Housing: aluminium alloy Shaft: stainless steel
Operating temperature	-40...+85 °C
Relative humidity	95 % non-condensing
Resistance	IEC 60068-2-6 Vibration 30 g, 10-2000 Hz IEC 60068-2-27 Shock 400 g, 1 ms
Corrosion protection	IEC 60068-2-52 Salt mist Complies to ISO 12944-5:1998 Protective paint systems (C5-M)
Weight approx.	2.2 kg (depending on version)
Connection	Bus connecting box Terminal box speed switch/incremental
HMG10-B - PROFINET	
Shaft type	ø16...20 mm (blind hollow shaft) ø17 mm (cone shaft 1:10)
HMG10-T - PROFINET	
Shaft type	ø16...20 mm (through hollow shaft)



Baumer

Baumer Hübner GmbH

P.O. Box 12 69 43 · 10609 Berlin, Germany

Phone: +49 (0)30/69003-0 · Fax: +49 (0)30/69003-104

info@baumerhuebner.com · www.baumer.com/motion

Original language of this instruction is German. Technical modifications reserved.