

Process displays

Analog measured value input, 2 limits

Large 14 mm display LED, 6-digits, programmable

PCD41



PCD41 - Process display

Technical data - electrical ratings

Voltage supply	24/48 VAC $\pm 10\%$ (50/60 Hz) 115/230 VAC $\pm 10\%$ (50/60 Hz) 12...30 VDC
Power consumption	6 VA, 4 W
Sensor supply	12...26 VDC / max. 80 mA
Display	LED, 7-segment display
Number of digits	6-digits
Digit height	14 mm
Function	Digital display of 1 analog measured value
Analog input	0(2)...10 V, 0(4)...20 mA Resolution 12 bit Temp. coeffic. typ. ± 20 ppm/ $^{\circ}$ C
Programmable parameters	Analog input Limits Control inputs Calculating functions Offset (maximum and minimum analogue limit)
Limits	Without, 2
Input logic	PNP
Control inputs	2 Inputs
Control functions	Hold, Reset, Keylock, etc.
Data memory	>10 years in EEPROM
Outputs relay	Normally open or closed, programmable
Interfaces	RS232, RS422, RS485
Standard DIN EN 61010-1	Protection class II Overvoltage category II Pollution degree 2
Emitted interference	DIN EN 61000-6-3
Interference immunity	DIN EN 61000-6-2

Features

- Process display
- Display 6-digits
- Connection: One-channel analog sensor
- Two limits as relay output
- With peak value memory
- Interface RS232 or RS422/RS485

Description

PCD41 is a display for measured values which signals are available as voltage or DC current. The operator is aligning the display by means of the front keypad. Two optional limits "P1" and "P2" that can be assigned at will allow production process control. Furthermore there is an electronic peak value memory (slave pointer).

Technical data - mechanical design

Ambient temperature	0...+50 $^{\circ}$ C
Storage temperature	-20...+70 $^{\circ}$ C
Relative humidity	80 % non-condensing
Core cross-section	1.5 mm ²
Protection DIN EN 60529	IP 65 (face with seal)
Operation / keypad	Membrane with softkeys
Housing type	Built-in housing
Dimensions W x H x L	96 x 48 x 124 mm
Cutout dimensions	92 x 44 mm (-0.6)
Mounting depth	124 mm
Mounting	Clip frame for built-in housing
Weight approx.	350 g (AC), 250 g (DC)
Material	Housing: Makrolon 6485 (PC)

Process displays

Analog measured value input, 2 limits

Large 14 mm display LED, 6-digits, programmable

PCD41

Part number

PCD41. PX01

Voltage supply

- 1 24 / 48 VAC
- 2 115 / 230 VAC
- 3 12...30 VDC

Inputs / outputs

- 0 0...10 V / no limits
- 1 0...20 mA / no limits
- 2 0...10 V / with limits
- 3 0...20 mA / with limits

Interface

- 0 Without interface
- 1 RS422 / RS485
- 2 RS232

Block circuit diagram

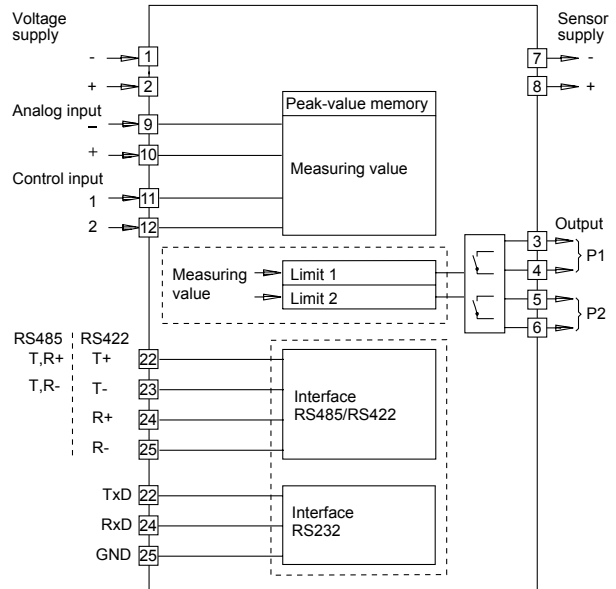

Connection diagram

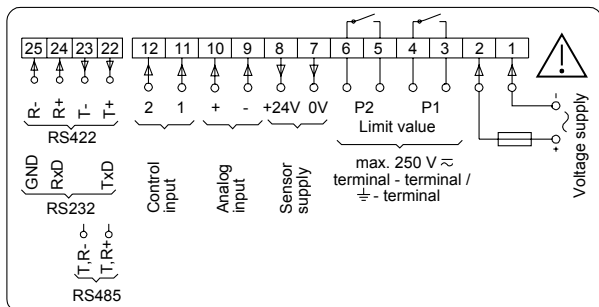

Trigger level

Comparator inputs	Input circuit
Control inputs	PNP-logic
Input level	Programmable
Input level Low	0...2 VDC
Input level High	3...40 VDC
Input resistance	3 kΩ
Relay outputs	Output circuit
Switching voltage max.	250 VAC / 110 VDC
Switching current max.	1 A
Switching capacity max.	150 VA / 30 W
Relay responding time	5 ms

Dimensions

