

Resolvers

Solid shaft $\varnothing 6$ mm with synchro flange

Number of pole pairs 1 (= 2 poles)

RTD 1 B14 Y 1



RTD 1 B14 Y 1 with synchro flange

Features

- Robust resolver with solid shaft $\varnothing 6$ mm
- Rotation speed max. 10000 rpm
- Centering alignment $\varnothing 50$ mm
- Mounting hole circle $\varnothing 68$ mm
- Wide operating temperature range
- Flange socket radial

Technical data - electrical ratings

Primary element	Rotor
Number of pole pairs	1 = 2 poles
Transformation ratio	0.5 \pm 5 %
Phase shift	0° \pm 10°
Interference immunity	DIN EN 61000-6-2
Emitted interference	DIN EN 61000-6-3

Technical data - mechanical design

Size (flange)	$\varnothing 58$ mm
Shaft type	$\varnothing 6$ mm solid shaft
Protection DIN EN 60529	IP 65
Operating speed	≤ 10000 rpm
Starting torque	≤ 0.01 Nm (+20 °C)
Shaft loading	≤ 20 N axial ≤ 40 N radial
Materials	Housing: aluminium, black, powder-coated Shaft: stainless steel
Operating temperature	-20...+100 °C
Resistance	DIN EN 60068-2-6 Vibration 20 g, 55-2000 Hz DIN EN 60068-2-27 Shock 100 g, 11 ms
Weight approx.	450 g
Connection	Connector M23 type 2, 12-pin

Resolvers

Solid shaft ø6 mm with synchro flange
Number of pole pairs 1 (= 2 poles)

RTD 1 B14 Y 1

Part number

RTD 1 B14 Y 1 **P1** **7** **10** **0.5** **D2SR12** **6** **IP65**

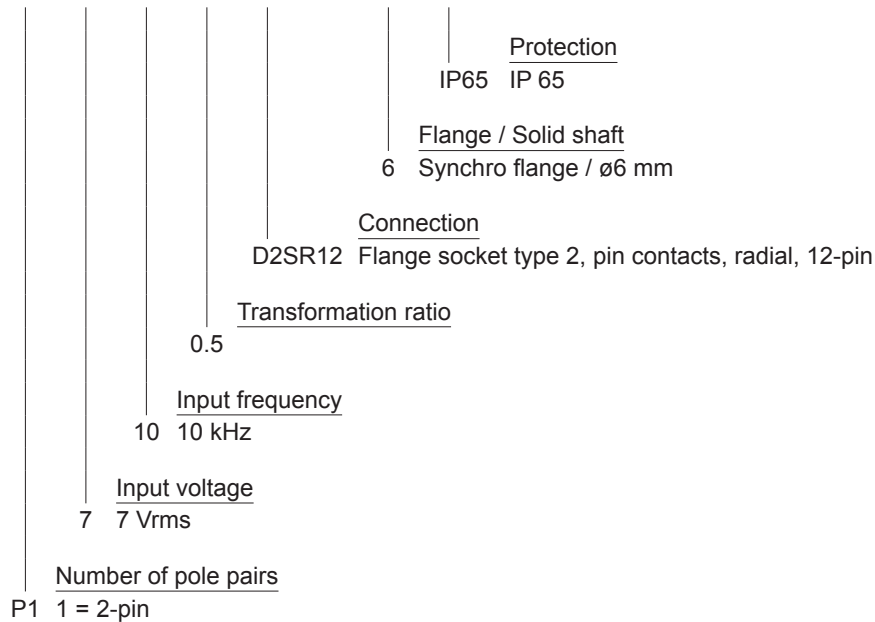

Accessories

Connectors and cables

11069601	Connector S2BG12, 2 m cable (RTD)
11069603	Connector S2BG12, 5 m cable (RTD)
11069605	Connector S2BG12, 10 m cable (RTD)

Resolvers

Solid shaft $\varnothing 6$ mm with synchro flange

Number of pole pairs 1 (= 2 poles)

RTD 1 B14 Y 1

Circuit diagram

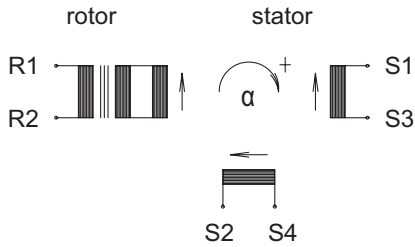

$$U_{S1-S3} = TR \cdot U_{R1-R2} \cdot \cos \alpha$$

$$U_{S2-S4} = TR \cdot U_{R1-R2} \cdot \sin \alpha$$

Schematic diagram, diagrammed during direction of rotation against counter-clockwise direction (ccw) when looking at the end of the mounting side.

Terminal assignment

Connector	Assignment
Pin 1	R1
Pin 2	R2
Pin 3	S2
Pin 4	S4
Pin 5	S1
Pin 6	S3
Pin 7	–
Pin 8	–
Pin 9	–
Pin 10	–
Pin 11	–
Pin 12	–

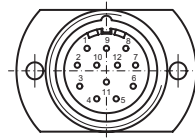

Impedances

Z_{RO}	[70+j100] Ω
Z_{SO}	[180+j300] Ω
Z_{SS}	[175+j275] Ω

DC resistance

R_R (rotor)	Approx. 36 Ω
R_S (stator winding)	Approx. 60 Ω
Max. zero voltage	20 mV

Resolvers

Solid shaft $\varnothing 6$ mm with synchro flange

Number of pole pairs 1 (= 2 poles)

RTD 1 B14 Y 1

Dimensions

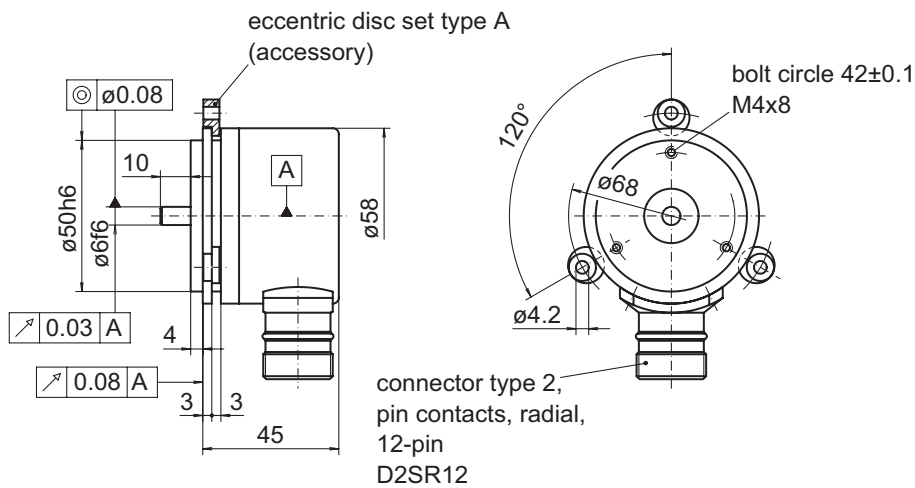

026-41 Y 1