

Resolvers

Blind hollow shaft $\varnothing 10$ to $\varnothing 16$ mm

Number of pole pairs 1 (= 2 poles)

RTD 4 A 4 Y 2



RTD 4 A 4 Y 2 with blind hollow shaft

Features

- Robust resolver with blind hollow shaft $\varnothing 10 \dots 16$ mm
- Rotation speed max. 8000 rpm
- Very high resistance to shock and vibrations
- Wide operating temperature range

Technical data - electrical ratings

Primary element	Rotor
Number of pole pairs	1 = 2 poles
Transformation ratio	0.5 \pm 5 %
Phase shift	0° \pm 10°
Interference immunity	DIN EN 61000-6-2
Emitted interference	DIN EN 61000-6-3

Technical data - mechanical design

Size (flange)	$\varnothing 80$ mm
Shaft type	$\varnothing 10 \dots 16$ mm (blind hollow shaft)
Protection DIN EN 60529	IP 65
Operating speed	≤ 8000 rpm
Starting torque	≤ 0.015 Nm (+20 °C)
Materials	Housing: aluminium, black, powder-coated Shaft: stainless steel
Operating temperature	-40...+100 °C
Resistance	DIN EN 60068-2-6 Vibration 10 g, 55-2000 Hz DIN EN 60068-2-27 Shock 100 g, 11 ms
Weight approx.	670 g
Connection	Connector M23 type 2, 12-pin
Motor shaft tolerance	0.25 mm axial 0.1 mm radial
Mounting kit	050

Resolvers

Blind hollow shaft $\varnothing 10$ to $\varnothing 16$ mm

Number of pole pairs 1 (= 2 poles)

RTD 4 A 4 Y 2

Part number

RTD 4 A 4 Y 2 | P1 | 7 | 10 | 0.5 | D2SR12 | | IP65 | 050

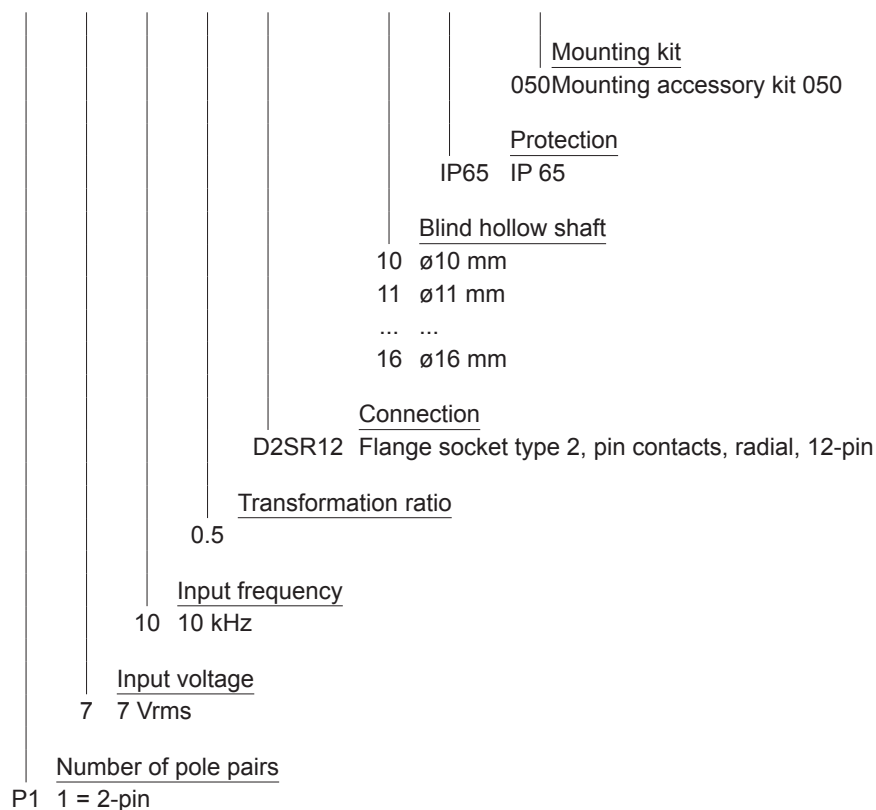

Accessories

Connectors and cables

11069601	Connector S2BG12, 2 m cable (RTD)
11069603	Connector S2BG12, 5 m cable (RTD)
11069605	Connector S2BG12, 10 m cable (RTD)

Resolvers

Blind hollow shaft $\varnothing 10$ to $\varnothing 16$ mm

Number of pole pairs 1 (= 2 poles)

RTD 4 A 4 Y 2

Circuit diagram

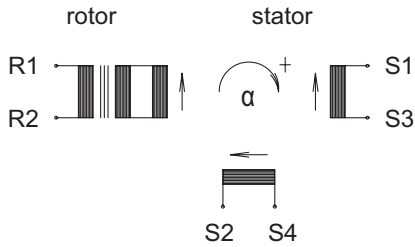

$$U_{S1-S3} = TR \cdot U_{R1-R2} \cdot \cos \alpha$$

$$U_{S2-S4} = TR \cdot U_{R1-R2} \cdot \sin \alpha$$

Schematic diagram, diagrammed during direction of rotation against counter-clockwise direction (ccw) when looking at the end of the mounting side.

Terminal assignment

Connector	Assignment
Pin 1	R1
Pin 2	R2
Pin 3	S2
Pin 4	S4
Pin 5	S1
Pin 6	S3
Pin 7	–
Pin 8	–
Pin 9	shield/housing
Pin 10	–
Pin 11	–
Pin 12	–

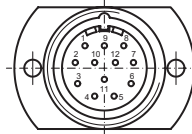

Impedances

Z_{RO}	$[70+j100] \Omega$
Z_{SO}	$[180+j300] \Omega$
Z_{SS}	$[175+j275] \Omega$

DC resistance

R_R (transformer)	Approx. 36Ω
R_S (stator winding)	Approx. 62Ω
Max. zero voltage	50 mV

Resolvers

Blind hollow shaft $\varnothing 10$ to $\varnothing 16$ mm

Number of pole pairs 1 (= 2 poles)

RTD 4 A 4 Y 2

Dimensions

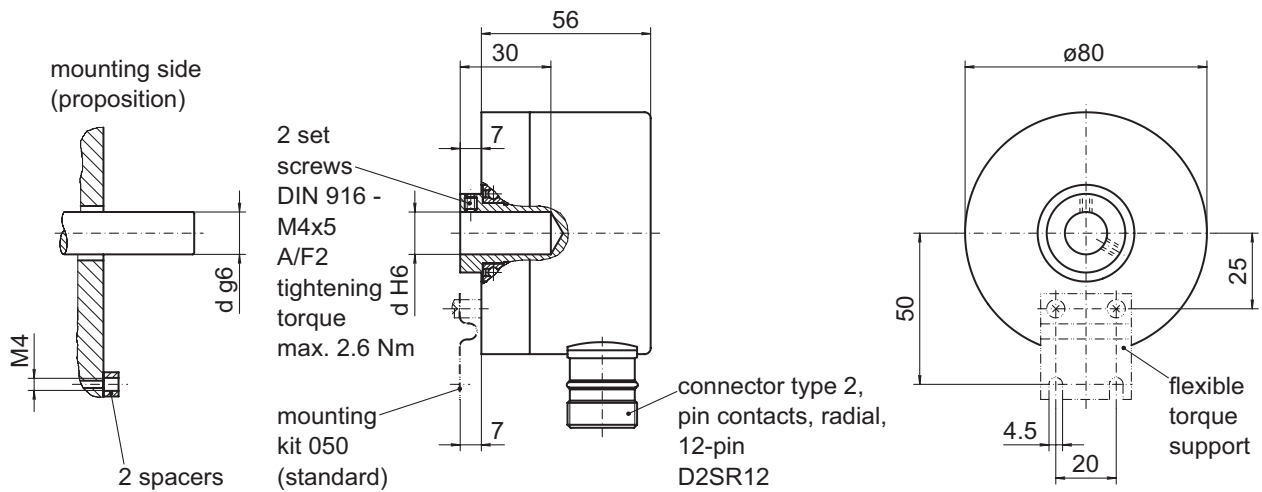

026-34 Y 2