

Accessories

Mounting accessories

Torque support and spring washer



Features

- Easy and cost-effective mounting
- For applications with low acceleration

Description

Push encoder onto drive shaft. Insert torque pin into the torque support provided by customer.

Part number

Z 119.024 Torque support and spring washer for encoders with 9.5 mm pin

Scope of delivery

Included: spring coupling, three screws M4 x 10 with spring washer and two lock washers

Suitable for

G0333 , G0A2H, G0M2H, G0P5H, GBA2S, GBAMS, GBMMS, GBP5H, GI330 , GI331 , GI332 , GI333 , GXA2S, GXAMS, GXM2S, GXM7S, GXMMS, GXP5S

Dimensions

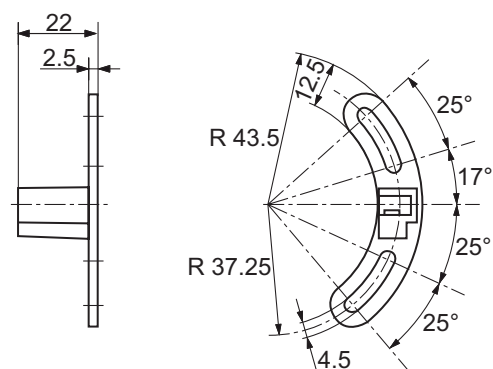

Dimension

