

Accessories

Mounting accessories

Spring washer for encoders GX and G1



Features

– Rigid spring coupling for high-dynamic applications

Description

Fix spring coupling onto flange by help of the attached screws. Push encoder onto the drive shaft and mount spring coupling onto the contact surface.

Part number

Z 119.043 Spring coupling for GX and G1

Scope of delivery

Included: spring coupling, seven screws M4 x 6 with seven lock washers

Suitable for

G110H, G110S, G1M2H, G1MMH, GXN1H, GXP1H, GXP6H, RXA1H

Dimensions

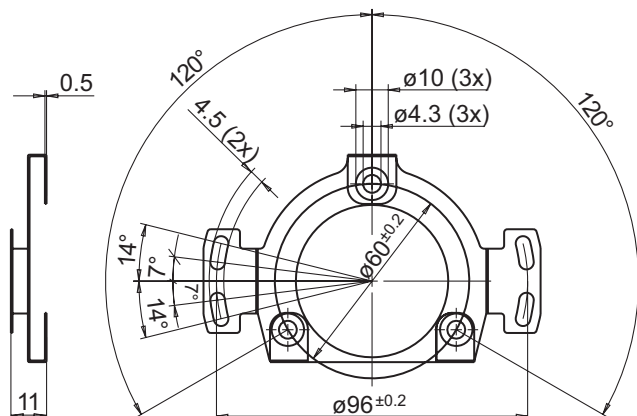

Dimension

