

# Accessories

## Mounting accessories

### Spring washer for encoders $\varnothing 58$ mm, hole spacing 63 mm



#### Features

- For high-dynamic applications and high demand on accuracy

#### Description

Fix spring coupling onto flange by help of the attached screws. Push encoder onto the drive shaft and mount spring coupling onto the contact surface.

#### Part number

Z 119.082 Spring coupling for encoders with  $\varnothing 58$  mm housing, hole distance 63 mm

#### Scope of delivery

Included: spring coupling, six screws M3 x 6 with six lock washers

#### Suitable for

G0A2H, G0AMH, G0M2H, G0MMH, G0P5H, GBA2H, GBA2S, GBAMH, GBAMS, GBM2H, GBM2S, GBMMH, GBMMS, GBP5H, GEMMH, GXA2S, GXAMS, GXM2S, GXM7S, GXMMS, GXP5S

#### Dimensions

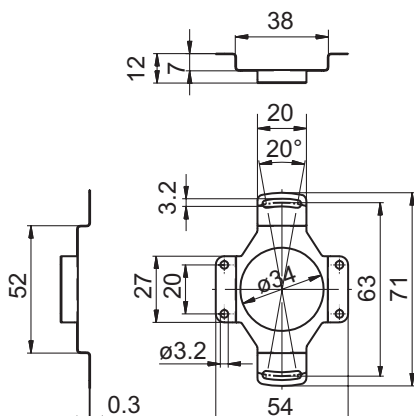

#### Dimension

