

# SmartReflect Light barriers

# FNDH 14G6902/IO

**dimension drawing**

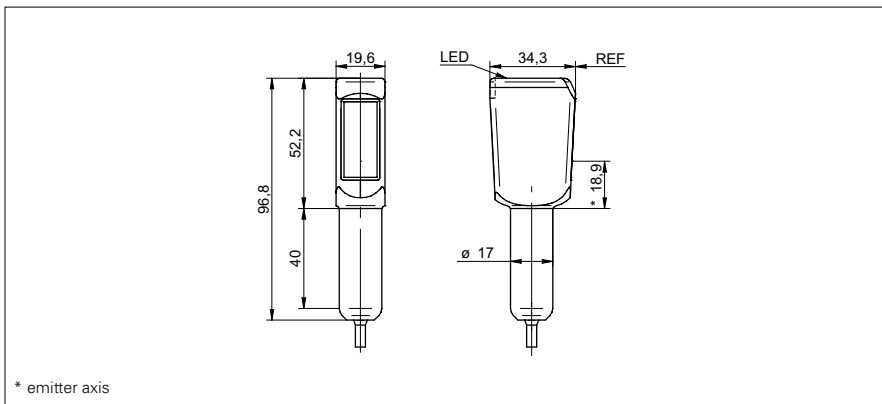

**general data**

type	light barrier
special type	hygienic design
version	Tray and bottle detection
light source	pulsed point source LED
background position Sde	200 ... 800 mm on V4A
minimal signal attenuation	30 %
alignment / soiled lens indicator	flashing light indicator
power on indication	LED green
output indicator	LED red
sensing distance adjustment	Teach-in and IO-Link
wave length	660 nm
approvals/certificates	Ecolab EHEDG

**photo**



**electrical data**

response time / release time	< 1,8 ms
voltage supply range +Vs	10 ... 30 VDC
current consumption max. (no load)	40 mA
current consumption typ.	35 mA
voltage drop Vd	< 2 VDC
output function	light / dark operate
output circuit	push-pull
output current	< 100 mA
short circuit protection	yes
reverse polarity protection	yes, Vs to GND

**connection diagram**

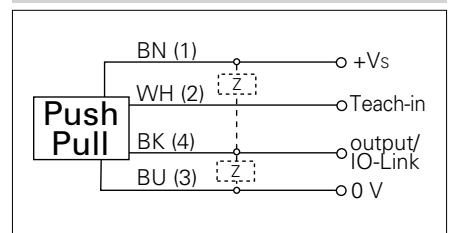

**mechanical data**

width / diameter	19,6 mm
height / length	52,2 mm
depth	34,3 mm
type	rectangular
housing material	stainless steel 1.4404 (V4A)
front (optics)	PMMA
connection types	cable 4 pin, 2 m



- Sensor FDA compliant, EHEDG certified and Ecolab approved
- IO-Link: output signal, service status, object presence
- sensitivity adjustable: via Teach-in wire input

## SmartReflect Light barriers

## FNDH 14G6902/IO

### ambient conditions

operating temperature	-30 ... +60 °C
protection class	IP 68/69K & proTect+
storage temperature	-30 ... +70 °C