

Inductive distance measuring sensors

IWRM 18Z8704/S14C

dimension drawing

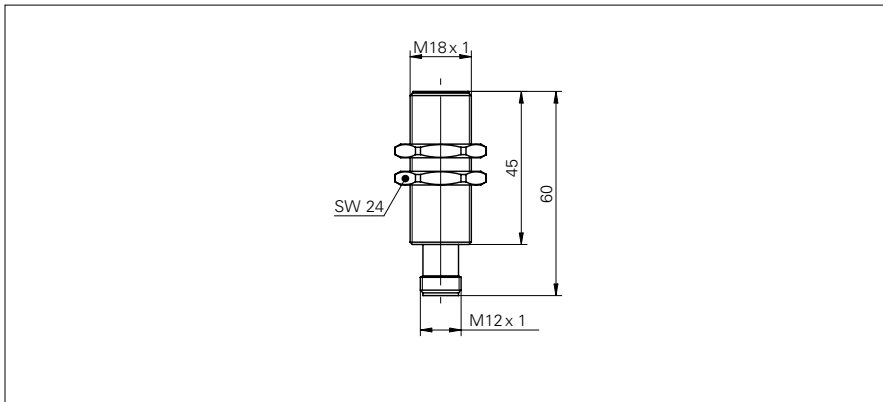

general data

mounting type	quasi-flush
special type	2 adjust. switching points linearized
measuring distance Sd	0 ... 8 mm
resolution	< 0,01 mm (stat.) < 0,01 mm (dynam.)
repeat accuracy	< 0,015 mm
adjustment	external Teach-in
linearity error	± 32 µm
temperature drift	± 5 % (Full Scale)

electrical data

response time (factory characteristic)	< 2 ms
response time (teach in characteristic)	< 3,1 ms
voltage supply range +Vs	15 ... 30 VDC
current consumption max. (no load)	20 mA
output circuit	voltage output / PNP
output signal	0 ... 10 VDC
load resistance	> 1000 Ohm
output current	< 10 mA (PNP)
voltage drop Vd	< 5 VDC (PNP)
short circuit protection	yes
reverse polarity protection	yes

mechanical data

type	cylindrical threaded
housing material	brass nickel plated
dimension	18 mm
housing length	60 mm
connection types	connector M12

ambient conditions

operating temperature	-10 ... +70 °C
protection class	IP 67

photo



connection diagram

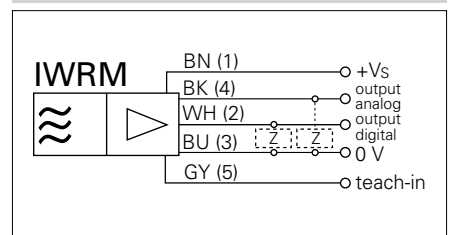

installation drawing

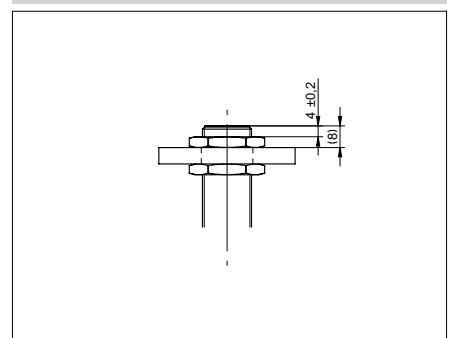

- external Teach-in
- integrated analog- and switching output
- linear analog output