

**Retro-reflective sensors**

**O300.RP.T-11157334**

**dimension drawing**

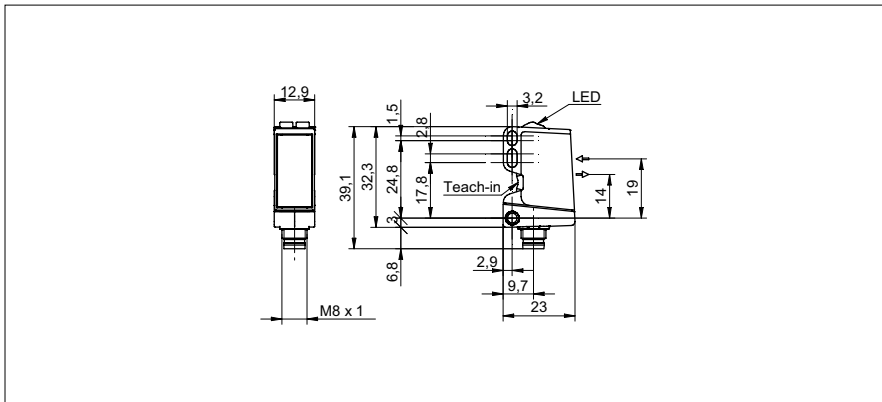

**general data**

type	retro-reflective sensor
version	transparency object detection
light source	pulsed PinPoint LED
actual range Sb	3,5 m
nominal range Sn	4 m
polarization filter	yes
minimal signal attenuation	10 % / 20 % / 30 %
light indicator	LED yellow
power on indication	LED green
sensitivity adjustment	Teach-in and IO-Link
wave length	630 nm
suppression of reciprocal influence	yes
alignment optical axis	< 2°

**photo**



**electrical data**

response time / release time	< 0,25 ms
voltage supply range +Vs	10 ... 30 VDC
current consumption max. (no load)	35 mA
current consumption typ.	30 mA
voltage drop Vd	< 3 VDC
output function	light / dark operate
output circuit	push-pull
output current	< 100 mA
short circuit protection	yes
reverse polarity protection	yes

**connection diagram**

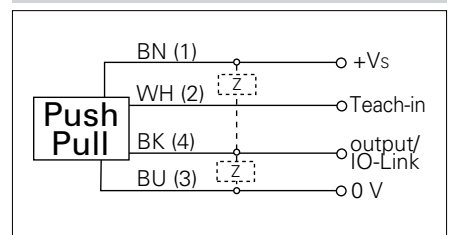

**mechanical data**

width / diameter	12,9 mm
height / length	32,3 mm
depth	23 mm
type	rectangular
housing material	plastic (ASA, PMMA)
front (optics)	PMMA
connection types	connector M8 4 pin



- qTeach
- IO-Link: V1.1, filter functions, qTeach lock adjustable
- signal attenuation adjustable

**Retro-reflective sensors****O300.RP.T-11157334****ambient conditions**

operating temperature	-25 ... +60 °C
protection class	IP 67