

TECHNICAL DATA

GENERAL DATA

Electrical contact life to 5 A, AC 230 V cos $\varphi = 1$	> 1.5×10^5 switching cycles	
Permissible operating frequency	max. 1200 operating cycles/h	
Short-circuit strength:	max. fuse rating	10 A gL IEC/EN 60947-5-1
	line circuit breaker	B 6 A
Mechanical life	> 20×10^6 switching cycles	
Ambient temperature range	-15 ... +55 °C	
EMC	according to IEC/EN 61000-4-2 to 5	
Degree of protection:	Housing	IP 40 IEC/EN 60529
	Terminals	IP 20 IEC/EN 60529
Wire connection	according to DIN 46 228-1/-2/-3/-4	
Screw terminals (integrated)	1 x 4 mm ² solid or 1 x 2.5 mm ² stranded ferruled, or 2 x 1.5 mm ² stranded ferruled, or 2 x 2.5 mm ² solid	
Housing material	thermoplastic, meets UL 94V-0	
Housing dimensions (W x H x D)	22.5 x 90 x 118 mm	
Mounting	on DIN rail	IEC/EN 60715
Weight	220 g	

SAFETY RELATED DATA

Category	4
PL	e
MTTF _d	> 100 years
DC _{avg}	99.0 %
d _{op}	220 days/year
h _{op}	12 hours/day
t _{cycle}	3.60E+03 s/cycle
SIL CL	3
SIL	3
HFT*	1
DC _{avg}	99.0 %
SFF	99.7 %
PFH _d	2.66E-10 h ⁻¹

STRUCTURE AND OPERATION (BLOCK DIAGRAM)

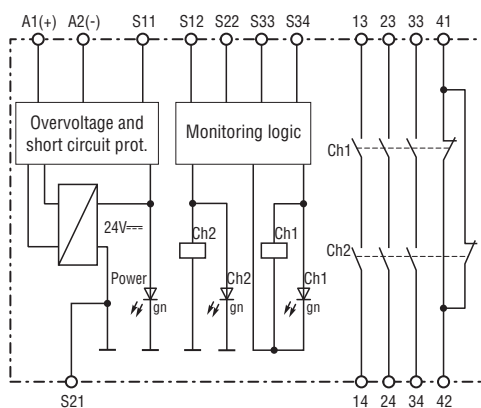

A1(+), A2(-) : connection operating voltage

13-14, 23-24, 33-34 : safety contacts (normally open)

S12, S22 : inputs for light curtain outputs

S33, S34 : bridge S33 and S34 for automatic restart

NOTES

When applying supply voltage to terminals A1(+) and A2(-), 'Power' LED illuminates. Terminals S12 and S22 must be connected to the safety light curtain outputs. When contacts 13-14, 23-24 and 33-34 are closed, the 'Channel 1' and 'Channel 2' LEDs illuminate.

The safety relay YRB-0131-241 can be operated in manual or automatic restart mode.

Warning: The same power supply must be used for the safety relay and both light curtain units. If this is not possible and these devices are connected to galvanically separated power supplies, then the OV contact of the light curtain units and the A2(-) contact of the safety relay must be bridged.

The gold-plated contacts of the YRB-0131-241 relay result in this device being also suitable for switching small loads of 1 mVA - 7 VA, 1 mW - 7 W in the range of 0.1 - 60 V, 1 - 300 mA. The contacts also support the maximum switching current.

To operate light curtains with symmetric outputs (both channels + switching), the selector switch S1 has to be in position "without". To operate light curtains with asymmetric outputs (one channel switching +, one channel -), the selector switch S1 has to be in position "with". The channel switching - must be connected to S22, the channel switching + to S12.

PART REFERENCE

Safety relay	YRB-0131-241
--------------	--------------

CONNECTION EXAMPLES FOR APPLICATIONS

In these examples, the Safetinx YBB/YCA light curtain/barrier is operating in channel 1 mode.

MANUAL RESTART MODE

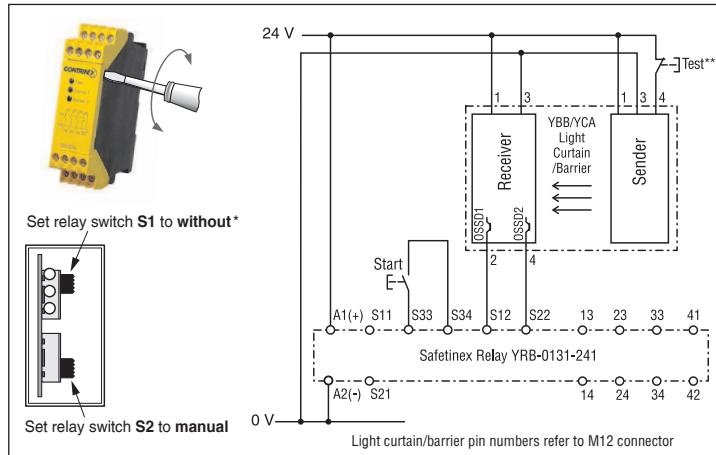

AUTOMATIC RESTART MODE

(For YBB models only. Automatic restart is not allowed for YCA access control devices)

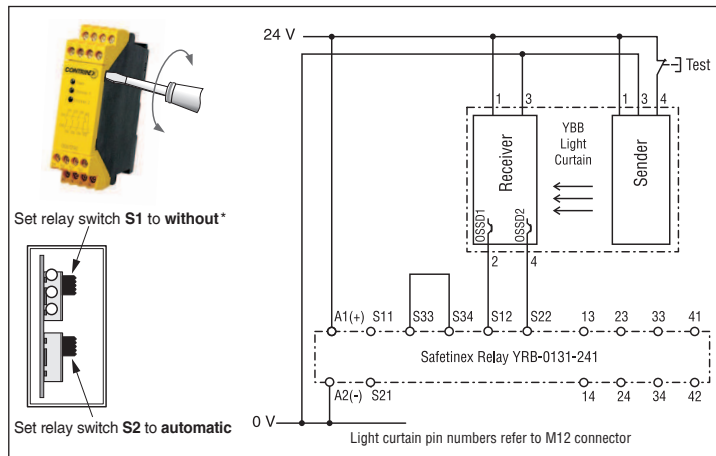

* Position of switch S1: – With symmetric outputs on light curtain (such as Safetinx YBB and YCA models), set switch S1 to "without".
– With asymmetric outputs on light curtain, set switch S1 to "with".

** The Test function is only applicable for YBB models.
Disconnect unit before setting S1

USING EXTERNAL CONTACTORS

