

DCCQ 05 M 1.5 NSLK

Inductive Proximity Switch

- Cable, highly flexible
- Integrated amplifier
- Short-circuit protection
- Starting pulse suppression
- LED

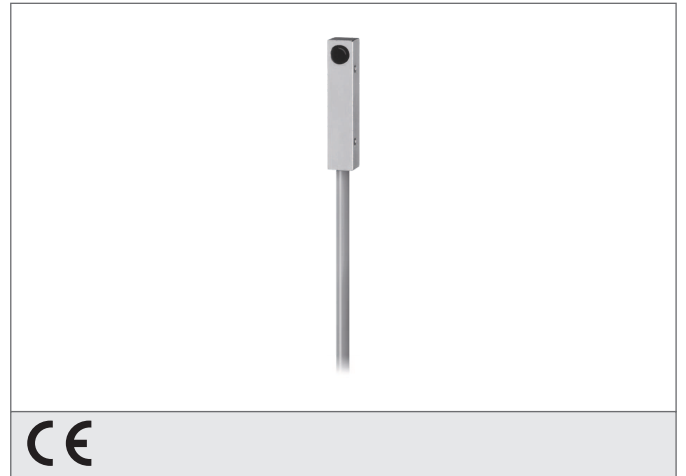

Safety instructions

The Instruments are not to be used for safety applications, in particular applications in which safety of persons depends on proper operation of the instruments.

These instruments shall exclusively be used by qualified personnel.

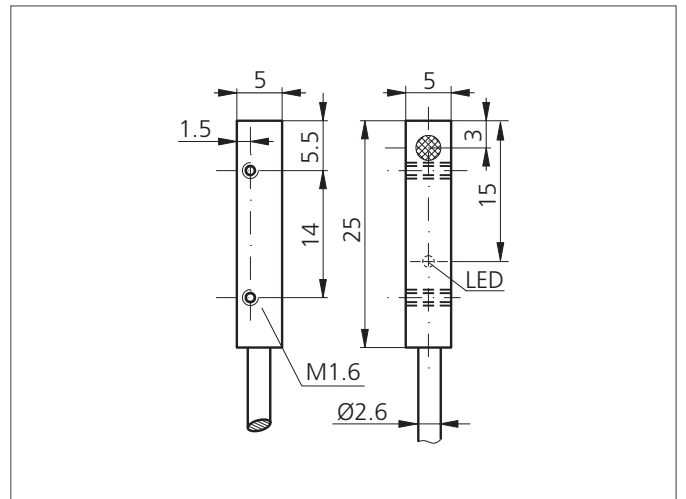

TECHNICAL INFORMATION (typ.)		+20°C, 24V DC
Operating principle		Inductive
Evaluation		digital
Size		5 x 5 x 25 mm (Dimensions)
Design		cuboid design
Mounting		flush
Characteristics		increased operating distance
Operating distance		1,5 mm
Standardized measuring plate		5 x 5 x 1 mm
Service voltage		10 ... 30 V DC
Internal power consumption		< 10 mA
Switching output		npn, 200 mA, NO
Switching hysteresis		5 %
Voltage drop		< 2,0 V
Switching frequency		3.000 Hz
Ambient temperature		-25 ... +70 °C
Insulation voltage endurance		500 V
Protection class		IP 67
Casing material		brass nickel plated
Connection		cable PUR, 2 m