

OHT 18 M 120 P1K-IBSL

Diffuse Sensor with Background Suppression

- Compact design
- Red light
- Sensitivity adjustable
- High resolution, operating frequency, functional reserve
- LED indication of output state and functional reserve
- High operating distance

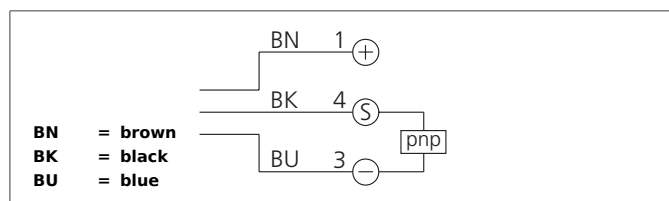

Safety instructions

The Instruments are not to be used for safety applications, in particular applications in which safety of persons depends on proper operation of the instruments.

These instruments shall exclusively be used by qualified personnel.

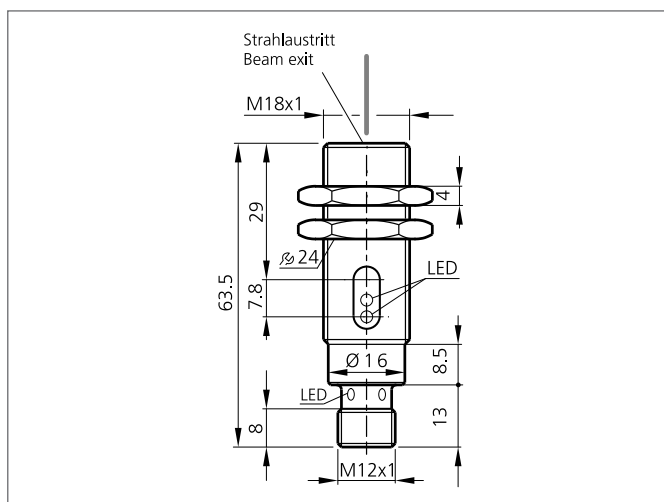

TECHNICAL INFORMATION (typ.)		+20°C, 24V DC
Operating principle		Diffuse reflective sensor
Evaluation		digital
Size		M18 x 1 (thread)
Design		screw
Emitted light		Red, 660 nm, clocked
Standardized measuring plate		100 x 100 mm, white
Service voltage		10 ... 35 V DC
Internal power consumption		< 25 mA
background suppression		yes
Operating distance		10 ... 120 mm
Sensitivity adjustment		potentiometer
Switching output		pnp, 200 mA, NO
Switching hysteresis		< 10 %
Voltage drop		< 2,0 V
Switching frequency		500 Hz
Response-/release time		< 1 ms / < 1 ms
Ambient temperature		-25 ... +55 °C
Temperature drift		0,3 %/K
Ambient light immunity		10 kLx
Insulation voltage endurance		1.000 V
Protection class		IP 65
Protection degree		III, operation on protective low voltage
Casing material		brass nickel plated

OHT 18 M 120 P1K-IBSL

Diffuse Sensor with Background Suppression

TECHNICAL INFORMATION (typ.)**+20°C, 24V DC**

Material

glass (Window)

Connection

Connector, M12, 3-poled