

US 17 T 1000 PSAK-TSSL

Ultrasonic Sensor

- Housing resistant against aggressive media and gases
- Scanning range adjustable
- Insensitive to dirt
- Insensitive to ambient noise
- Scanning does not depend on surface
- Switching output and analog output
- High follow-up speed
- High resolution
- Piezo-ceramic composite transducer

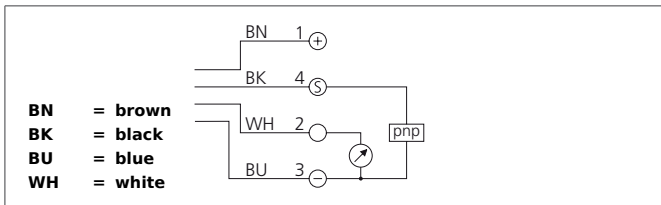

Safety instructions

The Instruments are not to be used for safety applications, in particular applications in which safety of persons depends on proper operation of the instruments.
 These instruments shall exclusively be used by qualified personnel.

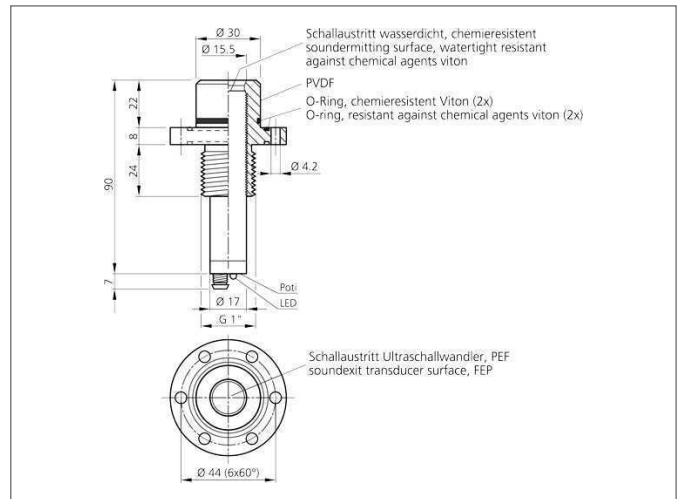

TECHNICAL INFORMATION (typ.)	+20°C, 24V DC
Operating principle	Ultrasonic sensor
Evaluation	digital, analog
Design	screw
Service voltage	18 ... 33 V DC
Internal power consumption	35 mA
Adjustment range	180 ... 1.000 mm
Sensitivity adjustment	potentiometer
Switching output	pnp, 100 mA, NO + analog
Switching hysteresis	60 ... 30 mm
Analog output	0 ... 10 V
Tracking speed	300 ms
Operating frequency	180.000 Hz
Ripple	100 mV
Linearity analog output	< 1 % / Sn max.
Switching frequency	7 Hz
Accuracy	< 2 % / Sn max.
Response-/release time	0,1 s
Ambient temperature	-20 ... +50 °C
Temperature drift	-0,17 %/K (air path), +3 mV/K (analog output)
Load resistance	> 10.000 Ω
Insulation voltage endurance	500 V
Protection class	IP 67
Casing material	PVDF / polyamide

US 17 T 1000 PSAK-TSSL
Ultrasonic Sensor



TECHNICAL INFORMATION (typ.)

Connection

+20°C, 24V DC

Connector, M8, 4-poled