

## WRB 120 MQ-10-0.6

### Glass fiber optic

- High-quality glass fibres
- Resistant to high temperature
- Robust, highly flexible

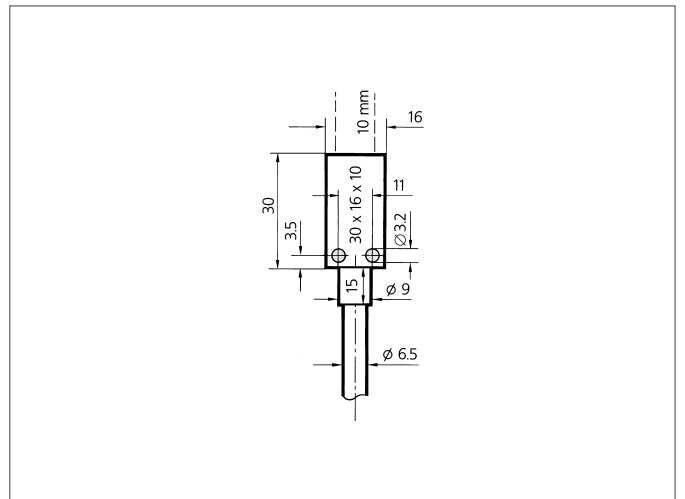
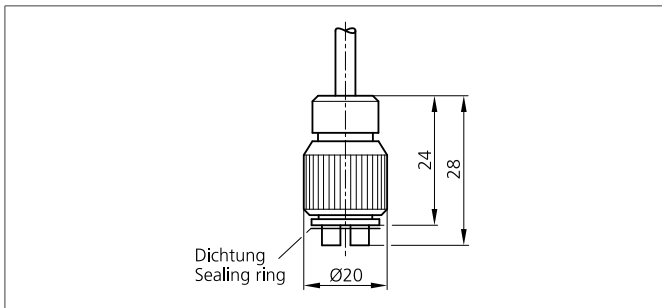

#### Safety instructions

The Instruments are not to be used for safety applications, in particular applications in which safety of persons depends on proper operation of the instruments.

These instruments shall exclusively be used by qualified personnel.

TECHNICAL INFORMATION (typ.)		+20°C, 24V DC
Operating principle		Diffuse reflective sensor
Design		cuboid design
Length		600 mm
Active diameter		10 x 0,6 mm
Opening angle		67°
Light outlet		axial
Operating distance		90 mm
single fibre		Ø 0,05 mm
Bending radius		≥ 10 x tube-Ø
Temperature resistance		-40 ... + 180 °C (short-term up to +300 °C)
Protection class		IP 60
For		Amplifier for glass fiber optics
Material		AL (Sensor probe) glass fibre (Fibre) Metal sleeve (Cladding)