

US 60 K 2500 PSI-I-TSSL

Ultrasonic Sensor

- Robust casing
- Compact design
- Scanning range adjustable
- Insensitive to dirt
- Insensitive to ambient noise
- Scanning does not depend on surface
- Switching output and analog output
- High follow-up speed
- High resolution
- Piezo-ceramic composite transducer

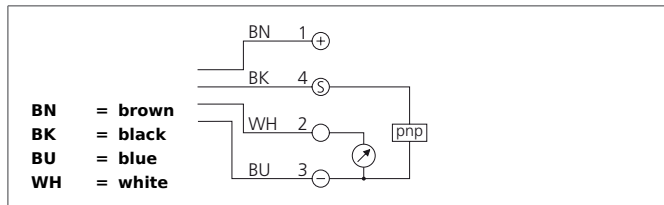

Safety instructions

The Instruments are not to be used for safety applications, in particular applications in which safety of persons depends on proper operation of the instruments.
 These instruments shall exclusively be used by qualified personnel.

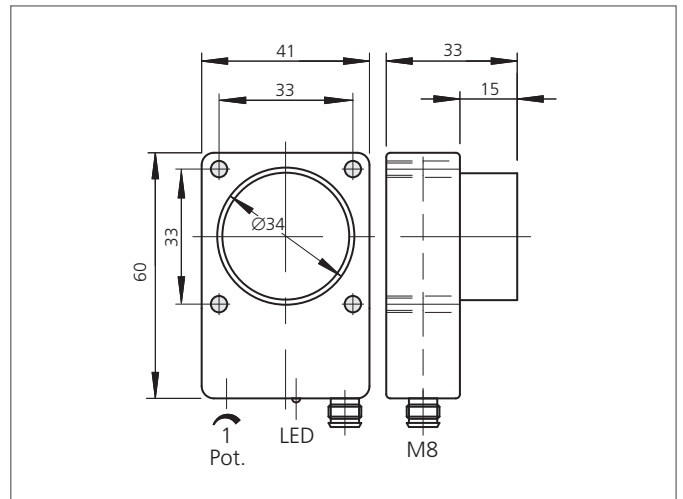

TECHNICAL INFORMATION (typ.)		+20°C, 24V DC
Operating principle		Ultrasonic sensor
Evaluation		digital, analog
Size		60 x 41 x 33 mm (Dimensions)
Design		cuboid design
Service voltage		15 ... 30 V DC
Internal power consumption		80 mA
Operating distance		250 ... 2.500 mm
Resolution		0,1 % / Sn max.
Switching output		pnp, 100 mA, NO + analog
Switching hysteresis		40 mm
Analog output		18,4 ... 4 mA
Tracking speed		400 ms (95% Sn max.)
Operating frequency		120.000 Hz
Ripple		15 mV
Linearity analog output		< 0,5 % / Sn max.
Switching frequency		3 Hz
Accuracy		< 1 % / Sn max.
Response-/release time		200 ms / 120 ms (50% Sn max.)
Ambient temperature		-20 ... +50 °C
Temperature error		1 % (-20 ... +50°C)
Load resistance		< 400 Ω
Insulation voltage endurance		500 V
Protection class		IP 67

US 60 K 2500 PSI-I-TSSL

Ultrasonic Sensor



TECHNICAL INFORMATION (typ.)		+20°C, 24V DC
Casing material		polyamide
Connection		Connector, M8, 4-poled