

WRB 120 S-SG-4.5-2.5

Glass fiber optic

- To operate colour sensors with fibre optic connection
- High-quality glass fibres
- Arrangement of fibres statistically mixed
- Resistant to high temperature
- Robust, highly flexible

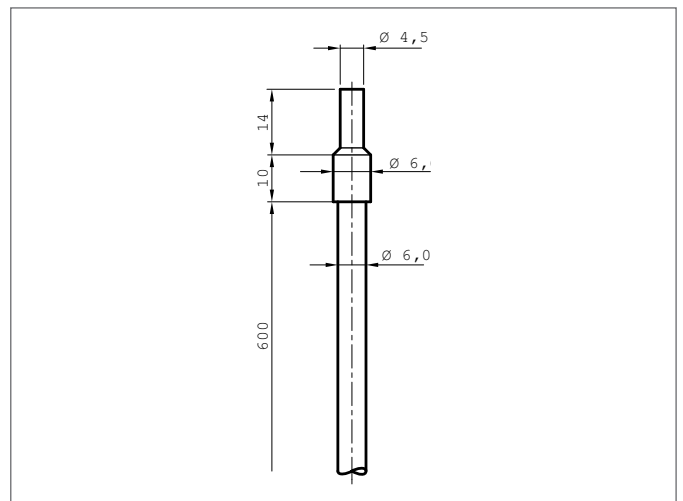
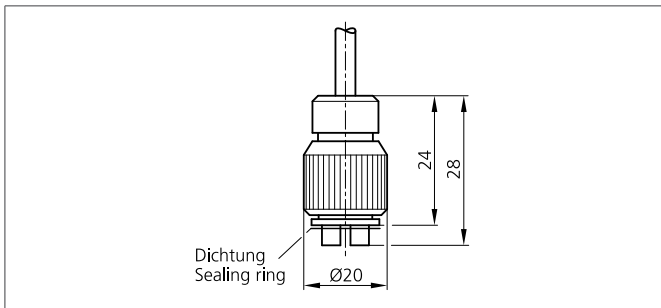

Safety instructions

The Instruments are not to be used for safety applications, in particular applications in which safety of persons depends on proper operation of the instruments.

These instruments shall exclusively be used by qualified personnel.

TECHNICAL INFORMATION (typ.)	+20°C, 24V DC
Operating principle	Diffuse reflective sensor
Design	screw
Length	600 mm, (fibre optic cable)
Active diameter	Ø 2,5 mm
Opening angle	67°
Light outlet	axial
Mounting hole	Ø 4,5 mm
single fibre	Ø 0,05 mm
Bending radius	≥ 3 x tube-Ø
Temperature resistance	-40 ... + 180 °C (short-term up to +250 °C)
Protection class	IP 67
For	Colour Sensors, Amplifier for glass fiber optics
Material	V2A (Sensor probe) glass fibre (Fibre) Silicone-metal sleeve (Cladding)