

# OTV 18 M 600 N4K-IBSL

## Diffuse Sensor

- Compact design
- Red light
- Sensitivity adjustable
- High resolution, operating frequency, functional reserve
- LED indication of output state and functional reserve
- High operating distance

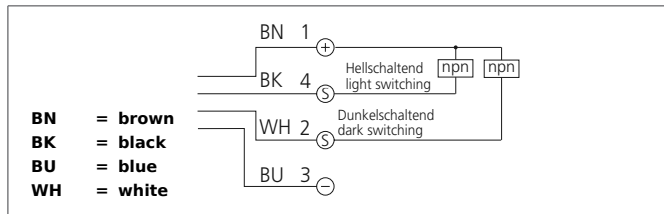

### Safety instructions

The Instruments are not to be used for safety applications, in particular applications in which safety of persons depends on proper operation of the instruments.  
 These instruments shall exclusively be used by qualified personnel.

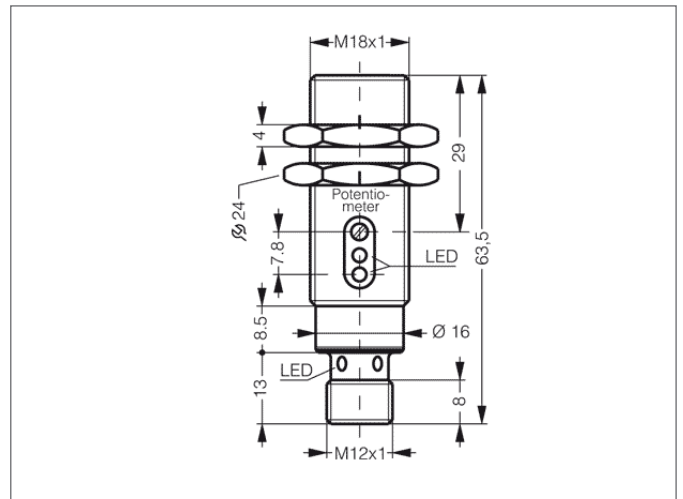

TECHNICAL INFORMATION (typ.)		+20°C, 24V DC
Operating principle		Diffuse reflective sensor
Evaluation		digital
Size		M18 x 1 (thread)
Design		screw
Emitted light		Red, 660 nm, clocked
Standardized measuring plate		200 x 200 mm, white
Service voltage		10 ... 36 V DC
Internal power consumption		< 20 mA
background suppression		no
Operating distance		600 mm
Sensitivity adjustment		potentiometer
Switching output		npn, 200 mA, exclusive OR
Switching hysteresis		< 10 %
Voltage drop		< 2,0 V
Switching frequency		1.000 Hz
Response-/release time		< 0,5 ms / < 0,5 ms
Ambient temperature		-25 ... +55 °C
Temperature drift		0,3 %/K
Ambient light immunity		10 kLx
Insulation voltage endurance		1.000 V
Protection class		IP 67
Protection degree		III, operation on protective low voltage
Casing material		brass nickel plated

# OTV 18 M 600 N4K-IBSL

## Diffuse Sensor



TECHNICAL INFORMATION (typ.)		+20°C, 24V DC
Material		glass (Window)
Connection		Connector, M12, 4-poled