

BE-F100/100-F0-K Backlight

- High excess current factor
- Pulsed mode for inspection of fast moving objects
- Extremely powerful light for high depth of field
- Long-life thanks to intelligent thermal management
- Homogenous luminous field
- High protection class IP 67
- Robust metal casing

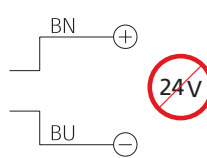



BN = brown
BU = blue

Betrieb ausschließlich mit Flash-Controller an einem *Supply Class 2* - Netzteil!
Use only with flash equipment driven by a power supply *Class 2*!
A utiliser exclusivement avec un contrôleur d'impulsion connecté à une alimentation *Class 2*!

Safety instructions

The Instruments are not to be used for safety applications, in particular applications in which safety of persons depends on proper operation of the instruments.
These instruments shall exclusively be used by qualified personnel.

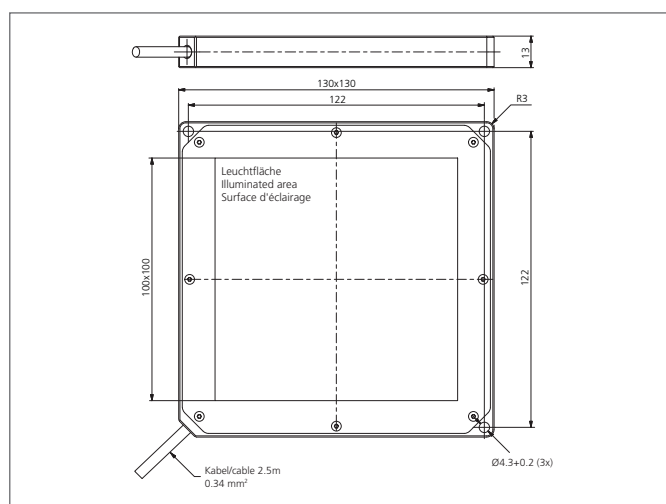

TECHNICAL INFORMATION (typ.)	+20°C, 24V DC
Pulse power consumption	275 W (max.)
Pulse overload factor	18
Pulse current capacity	12.800 mA
Design	Backlight
Illuminated area	100 x 100 mm
Characteristics	Flashable by means of flash controller
Light colour	Infrared, diffuse, 850 nm
Service voltage	No constant voltage!
Shock-/vibration load	10 ... 55 Hz / 1,0 mm / 30 g
Ambient temperature	0 ... +50 °C
Insulation voltage endurance	500 V
Protection class	IP 67
Risk group (DIN EN 62471)	Free group
Casing material	Aluminium black anodized
Material	PC, opal diffus (Protection optics)
Connection	cable PUR, 2.5 m, flying leads, Use only with flash equipment!