

DCC 6.5 V 04 PSK-TSL

Inductive Proximity Switch

- Metal plug
- Integrated amplifier
- Short-circuit protection
- Starting pulse suppression
- LED

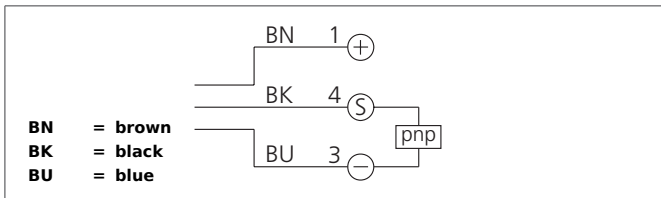

Safety instructions

The Instruments are not to be used for safety applications, in particular applications in which safety of persons depends on proper operation of the instruments.

These instruments shall exclusively be used by qualified personnel.

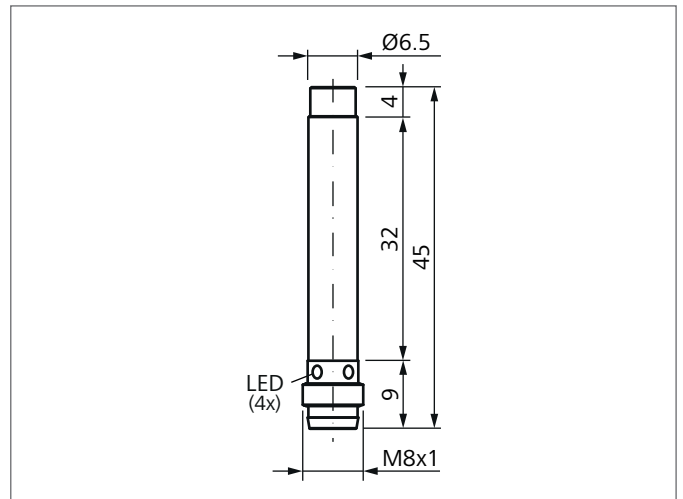

TECHNICAL INFORMATION (typ.)	+20°C, 24V DC
Operating principle	Inductive
Evaluation	digital
Size	Ø 6,5 mm (Diameter)
Design	cylinder
Mounting	non-flush
Operating distance	4 mm
Standardized measuring plate	9 x 9 x 1 mm
Service voltage	10 ... 30 V DC
Switching output	pnp, 200 mA, NO
Switching hysteresis	< 10 %
LED indicator	yes
Voltage drop	< 2,0 V
Switching frequency	< 1.000 Hz
Ambient temperature	-25 ... +70 °C
Protection class	IP 67
Protection degree	III, operation on protective low voltage
Casing material	brass chromium-plated
Connection	Connector, M8, 3-poled