

LHT9-45-SRG

Protection frame with glass insert

- Protection and sealing of the LHT 9-45 optics
- Real-glass scratch-proof window
- Robust design
- Easy installation and cleaning



Safety instructions

The Instruments are not to be used for safety applications, in particular applications in which safety of persons depends on proper operation of the instruments.
These instruments shall exclusively be used by qualified personnel.

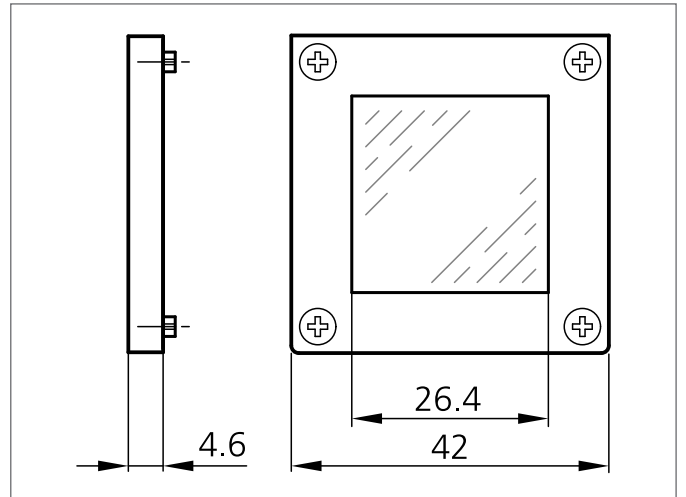

TECHNICAL INFORMATION (typ.)	+20°C, 24V DC
Mounting	4 holes
Size	42 x 42 x 4.6 mm (Dimensions)
Accuracy	The measured distance value can be changed by up to +5 mm.
Reproducibility	remains unchanged
For	Laser Distance Sensors LHT 9-45 M10...
Casing material	Die-cast zinc (Zamac - ZnAl4Cu1) black lacquered finish
Material	Glass, colourless transparent (protective glass) FPM 75+/-5 Shore A black (sealing) stainless steel V2A (1.4301 / AISI 304) (Screw)
Weight	39 g
Scope of delivery	1 front frame, 1 protective screen, 1 O-ring, 4 Phillips screws
Note	By soiling or scratching the window the repeatability and accuracy of the sensor can deteriorate.