

## MINISTART Softstarter For 1-phase Motors BI 9028/900

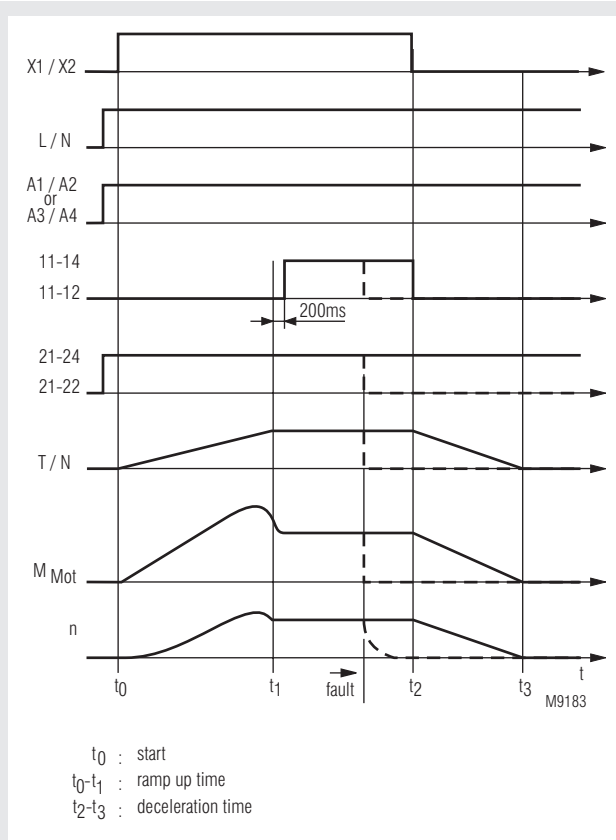

- Softstart and softstop function
- According to IEC/EN 60 947-4-2
- 1-phase motor control
- For motors up to 5 kW at AC 230 V
- Separate settings for start and deceleration time, as well as starting and deceleration torque
- Galvanic isolation of control input with wide voltage range up to AC/DC 230 V
- 3 auxiliary voltages up to 230 V
- phase failure detection
- 2 relay outputs for indication of status and fault
- LED-indication
- 90 mm width

### Function Diagram



### Approvals and marking



### Applications

- Motor with gear, belt or chain drive
- Fans, pumps, conveyor systems, compressors
- Woodworking machines, centrifuges
- Packing machines, door-drives

### Block Diagram

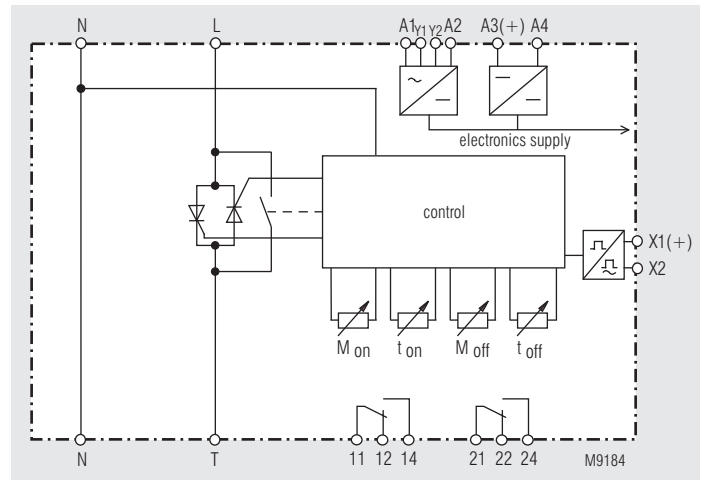

### Circuit Diagram

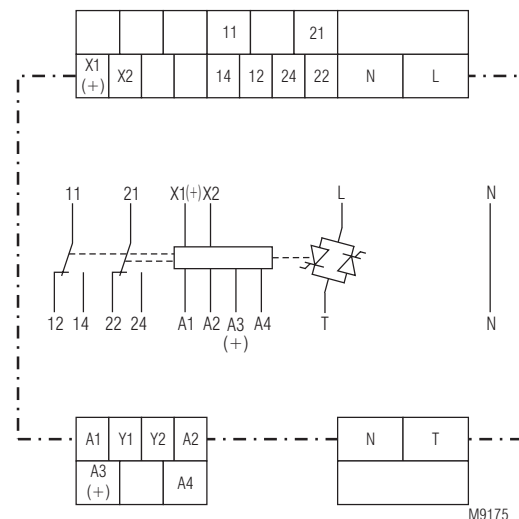

## Function

Softstarters are electronic devices for smooth start and stop of motors. The device ramps the motor current up and down by phase chopping therefore allowing the motor torque built up and reduce slowly. This reduces mechanical stress on the machine during start and stop. This prevents the connected mechanical equipment against damage caused by mechanical shock of the starting and stopping torque of a direct started motor. These features allow cost saving constructions of mechanical gear.

### Monitoring relay 1 (contact 11-12-14)

The relay indicates the status of the bridged semiconductor.

### Monitoring relay 2 (contact 21-22-24)

This relay energises as soon as the unit is ready for operation after connecting it to power. On internal overtemperature, phase failure, or wrong mains frequency the relay 2 de-energises. The power semiconductors are switched off. The internal temperature monitoring protects the thyristors. The fault is reset by disconnecting the power supply temporarily after the temperature is down again.

## Indication

green LED: Continuous light: when auxiliary supply connected  
Flashing light: while starting and braking

### Monitoring relay 1

yellow LED: Continuous light: when contact 11-12-14 switched on

### Monitoring relay 2

yellow LED: Continuous light: when contact 21-22-24 switched on  
Flashing light: when contact 21-22-24 switched off  
1\*): overtemperature on thyristor (internal)  
4\*): phase failure in load circuit  
6\*): incorrect frequency

1-6\*) = Number of flashing pulses in sequence

## Notes

Variation of speed is not possible with this device. Without load a softstart cannot be achieved. It is recommended that the softstart is protected by superfast semiconductor fuses rated as per the current rating of the softstart or motor. However, standard line and motor protection is acceptable, but for high starting frequencies motor winding temperature monitoring is recommended. The softstarter must not be operated with capacitive load e.g. power factor compensation on the output.

In respect to safety of persons and plant only qualified staff is allowed to work on this device.

## Technical Data

<b>Phase / motor voltage L1 / N:</b>	1 AC 100 V -10 % ... 480V + 10 %
<b>Nominal frequency:</b>	50 / 60 Hz
<b>Nominal motor power <math>P_N</math> at 230 V:</b>	5 kW
<b>Switching frequency</b> at $3 \times I_N$ , 5 s, $\vartheta_U = 20^\circ\text{C}$ :	45 / h
<b>Min. motor power:</b>	approx. 0,1 $P_N$
<b>Starting voltage:</b>	20 ... 80 %
<b>Deceleration voltage:</b>	20 ... 80 %
<b>Ramp time:</b>	0,25 ... 20 s
<b>Deceleration time:</b>	0,25 ... 20 s
<b>Auxiliary voltage:</b> Model AC 115/230 V: A1/A2, AC 115 V, +10%, -15%:	bridge A1 - Y1 bridge A2 - Y2
A1/A2, AC 230 V, +10%, -15%:	bridge Y1 - Y2
A3(+)/A4, DC 24 V, +10%, -15%:	polarity protected
<b>Power consumption:</b>	2 W
<b>Residual ripple max.:</b>	5 %
<b>Max. semiconductor fuse:</b>	1800 A <sup>2</sup> s

## Technical Data

### Inputs

<b>Control input X1/X2 voltage:</b>	AC/DC 24 - 230 V
<b>Softstart when:</b>	> 20 V
<b>Stopstart when:</b>	< 5 V

### Monitoring Output

<b>Contacts:</b>	2 x 1 changeover contacts	
<b>Thermal continuous current <math>I_{th}</math>:</b>	4 A	
<b>Switching capacity</b> to AC 15		
NO contact:	3 A / 230 V	IEC/EN 60 947-5-1
NC contact:	1 A / 230 V	IEC/EN 60 947-5-1
<b>Electrical life:</b> to AC 15 at 3 A, AC 230 V:	2 x 10 <sup>5</sup> switching cycles	
<b>Short circuit strength</b> <b>max. fuse rating:</b>	4 A gL	IEC/EN 60 947-5-1

### General Data

<b>Temperature range:</b>	0 ... + 45 °C	
<b>Storage temperature:</b>	- 25 ... + 75 °C	
<b>Clearance and creepage distances</b> rated impuls voltage / pollution degree		
Control voltage to auxiliary voltage, motor voltage:	6 kV / 2	IEC 60 664-1
Auxiliary to motor voltage:	4 kV / 2	IEC 60 664-1
<b>EMC</b>		
Electrostatic discharge:	8 kV (air)	IEC/EN 61 000-4-2
HF-irradiation:	10 V/m	IEC/EN 61 000-4-3
Fast transients:	2 kV	IEC/EN 61 000-4-4
Surge voltages between wire for power supply: between wire and ground:	1 kV 2 kV	IEC/EN 61 000-4-5 IEC/EN 61 000-4-5
<b>Degree of protection</b>		
Housing:	IP 40	IEC/EN 60 529
Terminals:	IP 20	IEC/EN 60 529
<b>Vibration resistance:</b>	Amplitude 0,35 mm IEC/EN 60 068-2-6 frequency: 10 ... 55 Hz	
<b>Climate resistance:</b>	0 / 055 / 04 IEC/EN 60 068-1	
<b>Wire connection</b> Load terminals:	1 x 10 mm <sup>2</sup> solid 1 x 6 mm <sup>2</sup> stranded ferruled	
Control terminals:	1 x 4 mm <sup>2</sup> solid or 1 x 2,5 mm <sup>2</sup> stranded ferruled (isolated) or 2 x 1,5 mm <sup>2</sup> stranded ferruled (isolated) DIN 46 228-1/-2/-3/-4 or 2 x 2,5 mm <sup>2</sup> stranded ferruled DIN 46 228-1/-2/-3	
<b>Wire fixing</b> Load terminals:	Plus-minus terminal screws M4 box terminals with wire protection	
Control terminals:	Plus-minus terminal screws M3,5 box terminals with wire protection	
<b>Mounting:</b>	DIN rail mounting IEC/EN 60 715	
<b>Weight:</b>	780 g	

### Dimensions

<b>Width x height x depth:</b>	90 x 85 x 121 mm
--------------------------------	------------------

## Standard Type

BI 9028.38/900 1 AC 100 ... 480 V 50/60 Hz 5 kW

Article number: 0058687

- Nominal motor power at AC 400 V: 5 kW
- Control input X1/X2
- Width: 90 mm

## Control input

The softstart begins by closing contact S connected to BI 9028/900. By opening contact S the deceleration begins. If contact S closes during deceleration the unit starts to ramp up again.

## Adjustment facilities

Potentiometer	Description	Initial setting
$M_{on}$	Starting voltage	fully anti-clockwise
$t_{on}$	Ramp-up time	fully clockwise
$M_{off}$	Deceleration voltage	fully anti-clockwise
$t_{off}$	Deceleration time	fully clockwise

## Set-up Procedure

### Softstart:

1. Start the motor via control input X1/X2 and turn potentiometer " $M_{on}$ " up until the motor starts to turn without excessive humming.
2. Adjust potentiometer " $t_{on}$ " to give desired ramp time.
3. On correct setting the motor should accelerate up to nominal speed. If the start takes too long fuses may blow, especially on motors with high inertia.

- **Attention:** If the ramp-up time is adjusted to short, the internal bridging contact closes before the motor is on full speed. This may damage the bridging contactor or bridging relay.



### Softstop:

- During softstop the device has to be connected to the voltage.
- Select softstop by opening control input X1/X2
- Adjust the voltage at which the deceleration stops with Pot.  $M_{off}$ .
- Adjust the deceleration time  $t_{off}$ .

## Temperature Monitoring

BI 9028/900 features overtemperature monitoring of its internal power semiconductors. The unit is therefore protected against overheating during the set up procedure. BI 9028/900 can be reset after the semiconductors have cooled down by momentarily removing the auxiliary supply voltage.

## Safety Instructions

- Never clear a fault when the device is switched on.
- **Attention:** This device can be started by potential-free contact, while connected directly to the mains without contactor (see application example). Please note, that even if the motor is at rest, it is not physically separated from the mains. Because of this the motor **must** be disconnected from the mains via the corresponding manual motor starter.
- The user must ensure that the device and the necessary components are mounted and connected according to the locally applicable regulations and technical standards.
- Adjustments may only be carried out by qualified specialist staff and the applicable safety rules must be observed.



## Connection Example

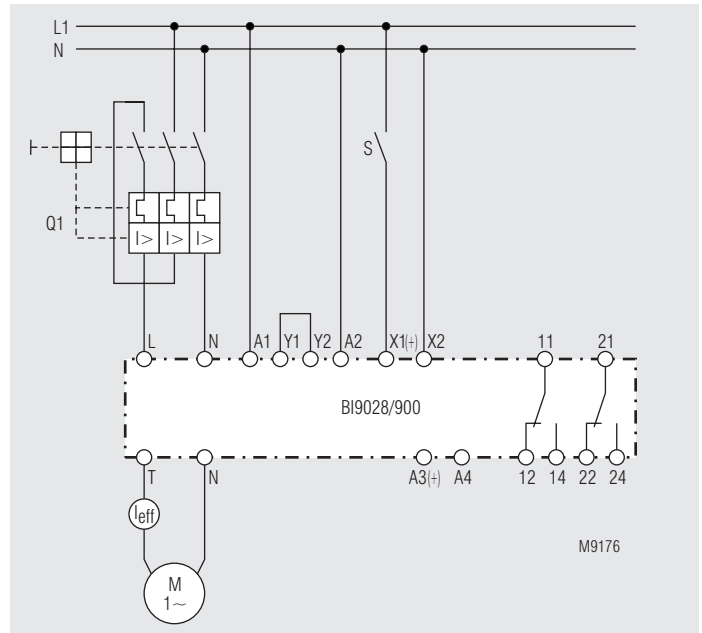

Softstart and softstop function with switch S

