

MINISTOP Motor Brake Relay BN 9034, GB 9034

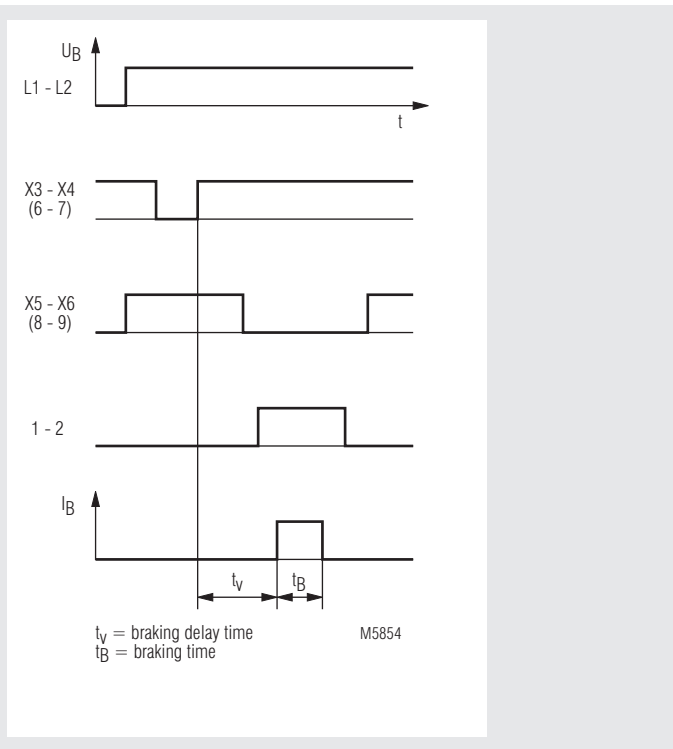

- DC brake with one way rectifier up to 600 A
- Can be used on all asynchronous motors
- Easy to fit also into existing control circuits
- Wear and maintenance free
- Integrated braking contactor for devices up to 60 A
- Mounting on 35 mm DIN-rail for 25 A units
- Adjustable braking current
- With automatic standstill monitoring
- as option with start-delta start function
- as option with thermistor motor protection
- as option with wide voltage input
- BN 9034: 200 ... 575 V
- GB 9034: 200 ... 690 V
- width max. 310 mm

Function Diagram



Approvals and Marking



Application

- Saws
- Centrifuges
- Woodworking machines
- Textile machines
- Transportation conveyors

Function

The supply voltage is connected to terminals L1-L2. The interlock contact for the motor contactor closes. The LED „ready“ indicates that the supply voltage is connected. The motor can be started with the start button. The DC voltage for the motor windings UV is supplied from T1-T2. The external braking contactor (Devices for > 60 A) is controlled by contact 1-2. This contact is timed in a way, that a safety time is provided between reset of the motor contactor and start of the brake contactor. This is necessary to avoid damage of the semiconductors by induced back EMF voltage. The timing of the different functions during braking is as follows: The motor contactor is switched off and disconnects the motor. After elapse of the safety time, the brake contactor is energized and shortly after that the brake current is switched on for the adjusted braking time.

Circuit Diagrams

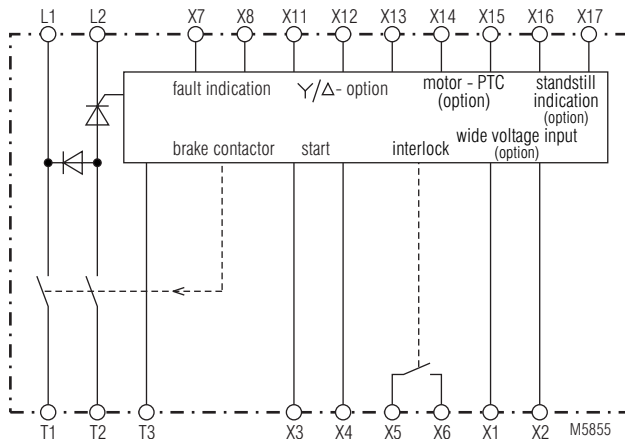

BN 9034

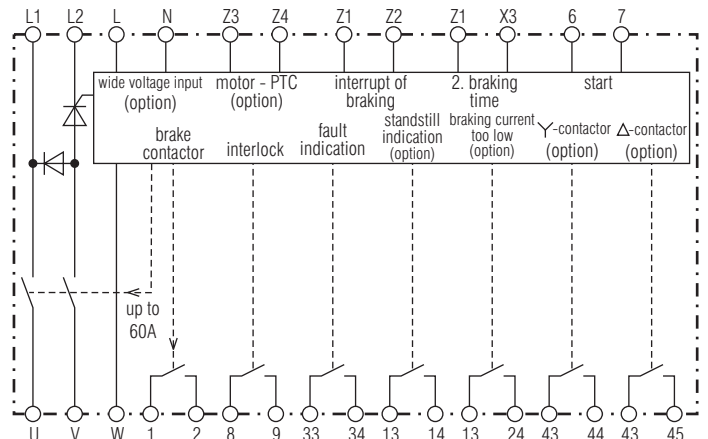

GB 9034

Indicators BN 9034

| | |
|--------------|--|
| LED „ready“: | On, when supply voltage connected flashing, when braking current is adjusted too high. |
| LED „I“: | On, when braking current is flowing. |

Notes

For optimum braking effect, the braking current should be 1,8 ... 2 times the nominal motor current. This current corresponds to the necessary saturation current of the magnetic field needed for braking. Higher currents show not much more effect, but will heat up the motor. A better braking effect is achieved by using more than one motor winding for braking. The permitted braking ration relates to the braking current, the ambient temperature and the brake model.

ATTENTION The terminal W or T3 serves as measuring input for the standstill monitoring, with 2.5 mm² max. cross section. With devices for > 40 A a fuse must be used to protect this connection wire at the point where the wire with smaller cross section is connected to the motor line. The choice of the fuse is suited to the used crossed section and serves the short circuit protection of the line.



Technical Data

| | | | | | | | |
|---|---|-------------------------|-----|-----|-----|-----|-----|
| Nominal voltage [U_N]: | AC 400 V ± 10 % others to 600V / 690 V on request | | | | | | |
| Nom. frequency [Hz]: | 50/60 | | | | | | |
| Motor power [kW] at 400 V: | BN 9034 | GB 9034 | | | | | |
| | 5,5 | 7,5 | 15 | 22 | 55 | 110 | 160 |
| Max. adjustable braking current [A]: | 25 | 40 | 60 | 100 | 200 | 400 | 600 |
| ED at max. braking current [%]: | 8 | 20 | 20 | 20 | 20 | 20 | 20 |
| Fuse, superfast [A]: | 25 | 40 | 60 | 100 | 200 | 400 | 630 |
| Braking voltage: | DC 0 ... 230 V | | | | | | |
| Max. braking time [s]: | 15 | 320 | | | | | |
| Back-EMF braking time delay: | selfoptimizing (100 ... 2500 ms) | | | | | | |
| Connection diameter | | | | | | | |
| Box terminal [mm²]: | 1,5 | 16 | 16 | 16 | 35 | | |
| Screw terminal: | | | | | | M12 | M12 |
| Power consumption for electronic [VA]: | 6 | | | | | | |
| Contacts: | 2 NO contacts 6 A / AC 250 V | | | | | | |
| Temperature range [°C]: | 0 ... + 45 | | | | | | |
| Storage temperature [°C]: | - 25 ... + 75 | | | | | | |
| Degree of protection: | IP 20 (25 A) | IP 20 (40 ... 600 A) | | | | | |
| Mounting: | to 25 A mounting on DIN-rail to 40 A screw fixing M5 | | | | | | |
| Weight [kg]: | 0,8 | 2,1 | 2,1 | 2,1 | 3,1 | | |

Technical Data

Dimensions:

Width x height x depth

BN 9034: 100 x 73 x 120 mm
GB 9034:

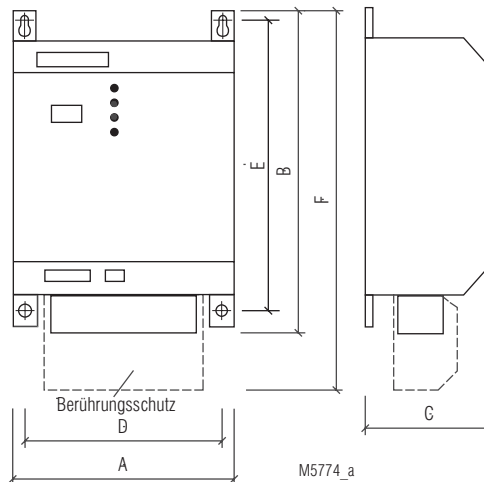

| | A | B | C | D | E | F |
|-------|-----|-----|-----|-----|-----|-----|
| 40 A | 110 | 242 | 140 | 86 | 226 | - |
| 60 A | 110 | 242 | 140 | 86 | 226 | - |
| 100 A | 110 | 242 | 140 | 86 | 226 | - |
| 200 A | 110 | 255 | 155 | 80 | 226 | - |
| 400 A | 210 | 275 | 165 | 180 | 226 | 340 |
| 600 A | 310 | 280 | 165 | 280 | 226 | 355 |

Dimensions in mm

| 40-100 A | PE | L1 | U | L2 | V | PE |
|----------|------|------|----|----|---|----|
| 200 A | PE | L1 | U | L2 | V | |
| 400 A | PE | L1/U | L2 | V | | |
| 600 A | L1/U | PE | V | L2 | | |

Wire connection configuration

Standard Type

BN 9034 25 A AC 400 V 50/60 Hz 15 s

Article number:

- Integrated braking contactor
- Mounting on 35 mm DIN-rail
- Width: 100 mm

Variant

BN 9034 /

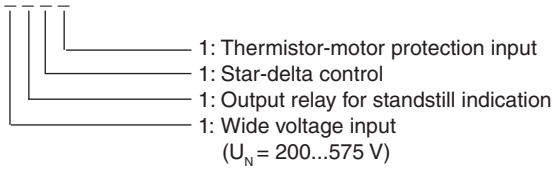

The 4 options can be ordered single or in combinations.

The variant with wide voltage input needs an auxiliary supply of AC 230 V or AC 24 V.

BN 9034 / 25 A AC 400 V 50 / 60 Hz 15 s

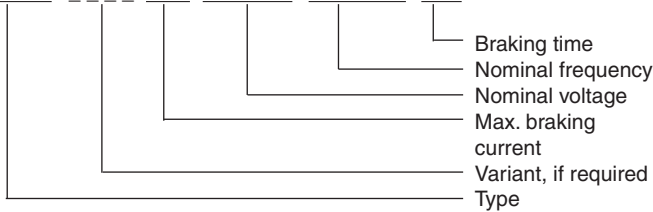

Inputs BN 9034

Opening the contact on terminal X3 and X4 makes the device ready for braking. When the contact is closed the braking current starts to flow. X14-X15 monitors the motor temperature (option)

Outputs BN 9034

- X5, X6: Interlock for monitor contactor
- X16, X17: Standstill indication (option)
- X7, X8: Fault indicating output
- X11, X12: Control of Y-contactor (option)
- X12, X13: Control of Δ-contactor (option)

Setting facilities BN 9034

| Potentiometer | function | initial setting |
|----------------|------------------|-------------------|
| I | braking current | left end of scale |
| t ₁ | braking time | middle of scale |
| n ₀ | standstill level | middle of scale |
| t ₂ | 2. braking time | left end of scale |

Standard Type

GB 9034 100 A AC 400 V 50/60 Hz

Article number: 0056975

- Screw fixing M5
- Width: 110 mm

Variant

GB 9034 /

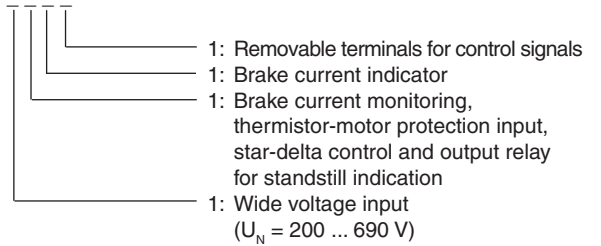

The 4 options can be ordered single or in combinations.

The variant with wide voltage input needs an auxiliary supply of AC 230 V.

GB 9034 / 100 A AC 400 V 50 / 60 Hz

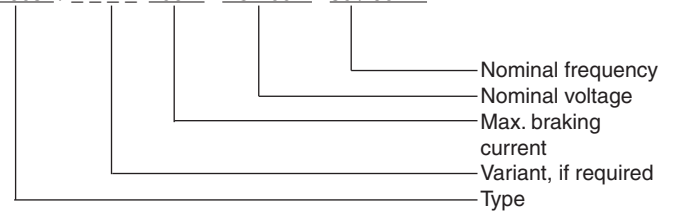

Inputs GB 9034

- Z3, Z4: Motor PTC
- Z1, Z2: Braking interrupt
- Z1, X3: 2. braking time
- 6,7: Start of braking

Outputs GB 9034

- 1,2: External braking contactor
- 8,9: Interlock for motor contactor
- 33,34: Fault indication output
- 43,44: Control of Y-contactor (option)
- 43,45: Control of Δ-contactor (option)
- 13,14: Standstill indication (option)
- 13,24: Braking current too low (option)

Set-up Procedure

The braking time cannot be set on the unit BN 9034. It is limited by the standstill detection. If the feedback input T3 is not connected to terminal W of the motor the standstill detection is disabled and the internal max. braking time of 15 s is valid. The GB 9034 allows to set different braking times and can be used for standstill depending as well as time depending braking function. More details are available in the operating manual.

With potentiometer I the braking current can be adjusted. With a current meter (true RMS) the current should be measured so that 2 times the braking current is not exceeded in order not to overheat the motor. The braking device cannot be overloaded, as it limits the current even on full potentiometer setting to the nominal current of the unit. This status is indicated by the flashing „ready“ LED.

Connection example

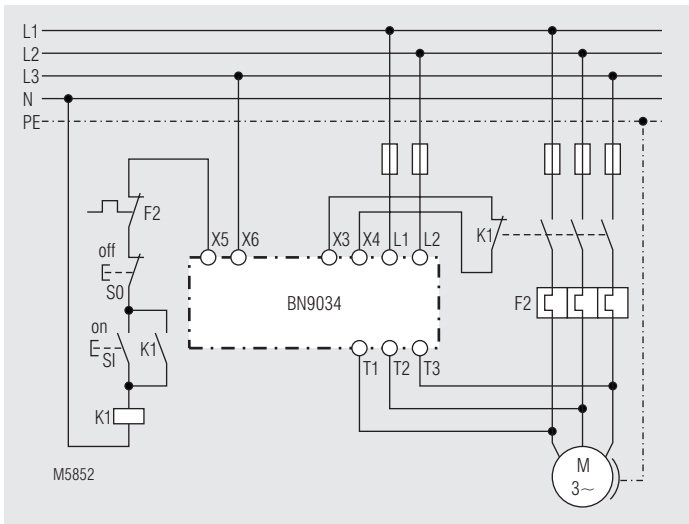

for BN 9034 25 A

Connection examples

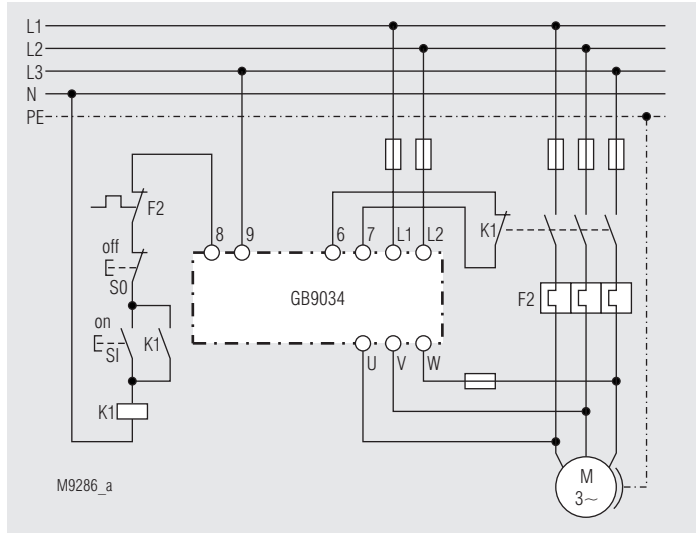

for GB 9034 40 A, 60 A

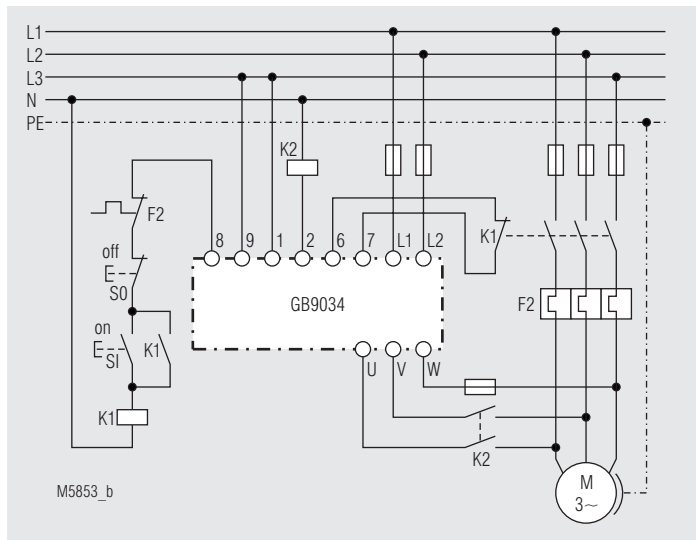

for GB 9034 from 100 A