

## Latching Relay MK 8852

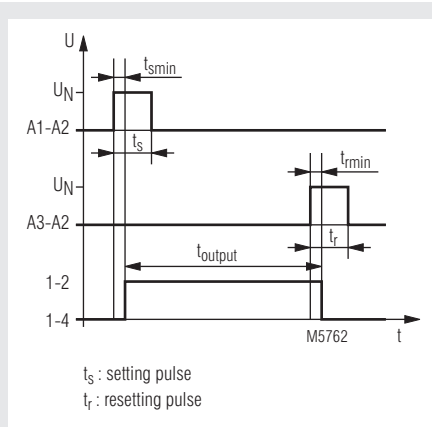

- According to IEC/EN 61 810-1
- Setting input A1 - A2
- Reset input A3 - A2
- Storage function
- Switch position indication
- Manual operation
- Width 22.5 mm

### Function Diagram



### Approvals and Marking



### Application

Impulse conversion into a permanent function\*

### Notes

Latching relays are designed for pulse operation. In case of cyclic pulsed operation, the recommended pulse duration for  $t_s$  and  $t_r$  are within 0.03 ... 2 s each. A pulse-interval-ratio of 25 % duty cycle is recommended. In no case the permissible operating frequency may be exceeded. For single pulse operation pulse times of > 2 s are possible. A recovery time (min off time between 2 impulses) of > 6 s is required.

In case of a failure a continuous control is possible.

Simultaneous energization of A1 and A3 ist not allowed!

### Circuit Diagrams

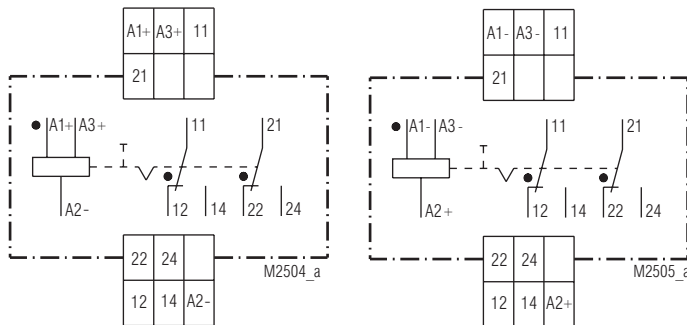

MK 8852.12

MK 8852.12/002

\* A pulse (input) is leading to a continuous function (output).

## Technical Data

### Input

<b>Operating mode:</b>	Impulse operation
<b>Nominal voltage <math>U_N</math>:</b>	AC / DC 24 V, 30 ... 80 V, 96 ... 150 V, 180 ... 240 V DC 110, 240 V 0.8 ... 1.1 $U_N$
<b>Voltage range:</b>	1.35 W
<b>Nominal consumption:</b>	50 / 60 Hz
<b>Nominal frequency:</b>	$\pm 5 \%$
<b>Frequency range:</b>	
<b>Min. pulse duration</b> ( $\hat{=}$ $t_{s \text{ min}}$ and $t_{r \text{ min}}$ ):	30 ms

### Output

<b>Contacts</b>	
MK 8852.12:	2 changeover contacts
<b>Operate time of contacts:</b>	10 ms
<b>Release time of contacts:</b>	10 ms
<b>Thermal current <math>I_{th}</math>:</b>	6 A
<b>Switching capacity</b>	IEC/EN 60 947-5-1
to AC 15:	4 A / 230 V
to DC 13:	1.5 A / 24 V 0.1 A / 230 V
<b>Electrical life</b>	IEC/EN 60 947-5-1
to AC 15 at 4 A, AC 230 V:	$> 1 \times 10^5$ switching cycles
<b>Permissible switching frequency:</b>	3 600 switching cycles/h ... continuous operation $\hat{=}$ $t_{\text{output}}$
<b>Short-circuit strength</b>	
<b>max. fuse range</b>	6 A gL IEC/EN 60 947-5-1
<b>Mechanical life:</b>	$10 \times 10^6$ switching cycles
<b>General Data</b>	

<b>Temperature range:</b>	- 25 ... + 50 °C
<b>Clearance and creepage distances</b>	
rated impuls voltage / pollution degree:	4 kV / 2 IEC 60 664-1
<b>EMC</b>	
Electrostatic discharge:	8 kV (air) IEC/EN 61 000-4-2
HF irradiation:	10 V/m IEC/EN 61 000-4-3
Fast transients:	4 kV IEC/EN 61 000-4-4
Surge voltages	
between	
wires for power supply:	2 kV IEC/EN 61 000-4-5
between wire and ground:	4 kV IEC/EN 61 000-4-5
HF-wire guided:	10 V IEC/EN 61 000-4-6
Interference suppression:	Limit value class B EN 55 011
<b>Degree of protection</b>	
Housing:	IP 40 IEC/EN 60 529
Terminals:	IP 20 IEC/EN 60 529
<b>Housing:</b>	Thermoplast with V0 behaviour according to UL subject 94
<b>Vibration resistance:</b>	Amplitude 0.35 mm frequency 10 ... 55 Hz IEC/EN 60 068-2-6
<b>Climate resistance:</b>	25 / 50 / 04 IEC/EN 60 068-1
<b>Terminal designation:</b>	EN 50 005
<b>Wire connection:</b>	2 x 2.5 mm <sup>2</sup> solid or 2 x 1.5 mm <sup>2</sup> stranded wire with sleeve DIN 46 228-1/-2/-3/-4 2 x 1.0 mm <sup>2</sup> stranded wire with sleeve DIN 46 228-1/-2/-3/-4
<b>Wire fixing:</b>	Flat terminals with self-lifting clamping piece IEC/EN 60 999-1
<b>Mounting:</b>	DIN rail IEC/EN 60 715
<b>Weight:</b>	120 g

### Dimensions

<b>Width x height x depth:</b>	22.5 x 82 x 102 mm
--------------------------------	--------------------

## Standard Type

MK 8852.12 AC 230 V		
Article number:	0059338	stock item
• Output:	2 changeover contacts	
• Nominal voltage $U_N$ :	AC 230 V	

## Variant

MK 8852.12/002:	for DC-models, reversed polarity on input
-----------------	--

## Ordering example for variant

