

Operating manual

Thermophant T TTR31, TTR35

Temperature switch

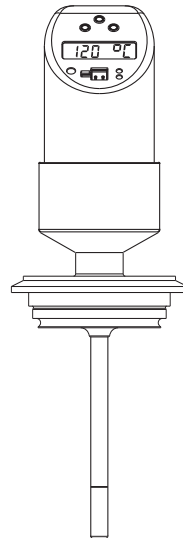
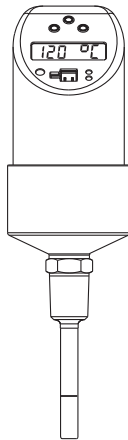

Brief overview

Using the following short form instructions you can commission your system easily and swiftly:

Safety instructions	→ 4
▼	
Installation	→ 7
▼	
Wiring	→ 12
▼	
Operation	→ 13
Display and operating elements On-site operation Operation with PC and configuration software	
▼	
Trouble-shooting	→ 29

Table of contents

1	Safety instructions	4	9	Technical data	31
1.1	Designated use	4	9.1	Power supply	31
1.2	Installation, commissioning and operation	4	9.2	Output	32
1.3	Operational safety	4	9.3	Operating conditions	32
1.4	Return	4			
1.5	Notes on safety conventions and icons	5	10	Dangerous good sheet	35
2	Device identification	6			
2.1	Nameplate	6			
2.2	Certificates and approvals	6			
3	Installation	7			
3.1	Incoming acceptance, storage	7			
3.2	Dimensions	7			
3.3	Process connection	8			
3.4	Installation instructions	10			
4	Wiring	12			
4.1	DC voltage version with M12x1 connector	12			
4.2	DC voltage version with valve connector	13			
5	Operation	13			
5.1	On-site operation	13			
5.2	Operation with PC	23			
6	Maintenance	25			
7	Accessories	25			
7.1	Welding bosses and coupling	25			
7.2	Electrical connection	27			
7.3	Configuration kit	28			
7.4	Configuration software	28			
8	Trouble-shooting	29			
8.1	Errors and warnings	29			
8.2	Repair	30			
8.3	Disposal	30			
8.4	Software history and compatibility overview	31			

1 Safety instructions

1.1 Designated use

The Thermophant T is a temperature switch for monitoring, displaying and regulating process temperatures. The device has been safely built with state-of-the-art technology and meets the applicable requirements and EC Directives. It can, however, be a source of danger if used incorrectly or for anything other than the designated use.

1.2 Installation, commissioning and operation

Installation, electrical connection, commissioning, operation and maintenance of the measuring system must be carried out by trained, qualified specialists authorised to perform such work by the facility's owner-operator. The specialist must have read and understood these Operating Instructions and must follow the instructions they contain. The device may only be modified and repair work carried out if this is explicitly permitted in the Operating Instructions. Damaged devices which could be a source of danger may not be commissioned and must be labelled and identified as defective.

1.3 Operational safety

The measuring device meets the general safety requirements according to EN 61010-1 and the EMC requirements according to IEC/EN 61326 in addition to the NAMUR recommendations NE 21, NE 43 and NE 53.

■ Functional safety

The Thermophant T temperature switches were developed according to the standards IEC 61508 and IEC 61511-1 (FDIS). The device version with PNP switch output and additional analog output is equipped with fault detection and fault prevention facilities within the electronics and software.

■ Ex-area

The Thermophant T is not approved for use in Ex-areas.

1.4 Return

The following procedures must be carried out before a device is returned to Endress+Hauser:





- Always enclose a fully completed "Declaration of Contamination" form with the device. Only then can Endress+Hauser transport and examine a returned device. A copy of the "Declaration of Contamination" can be found on the second last page of these Operating Instructions.
- Remove all fluid residues. This is particularly important if the fluid is hazardous to health, e.g. flammable, toxic, caustic, carcinogenic, etc.

⚠ CAUTION

Do not return a measuring device if you are not absolutely certain that all traces of hazardous substances have been removed, e.g. substances which have penetrated crevices or diffused through plastic.

1.5 Notes on safety conventions and icons

Always refer to the safety instructions in these Operating Instructions labeled with the following symbols:

Symbol	Meaning
 <small>A0011190-EN</small>	WARNING! This symbol alerts you to a dangerous situation. Failure to avoid this situation can result in serious or fatal injury.
 <small>A0011191-EN</small>	CAUTION! This symbol alerts you to a dangerous situation. Failure to avoid this situation can result in minor or medium injury.
 <small>A0011192-EN</small>	NOTICE This symbol contains information on procedures and other facts which do not result in personal injury.
 <small>A0011193</small>	Indicates additional information, Tip

2 Device identification

2.1 Nameplate

To identify your device, compare the complete order code and the version information on the delivery papers with the data on the nameplate.

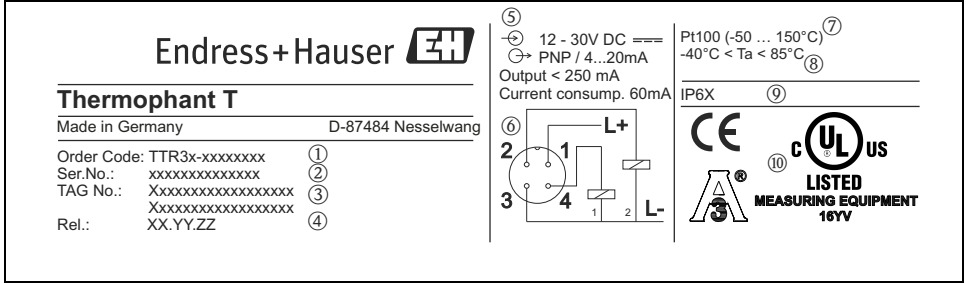

Fig. 1: Nameplate for device identification (as example)

A0008138

①	Order code	⑥	Connection diagram
②	Serial number	⑦	Measuring range
③	TAG number	⑧	Ambient temperature
④	Release number (change status)	⑨	Degree of protection
⑤	Connection values	⑩	Approvals



The release number indicates the change status of the device. A change in the last two figures does not have any affect on the compatibility - see also → 31.

2.2 Certificates and approvals

CE mark, declaration of conformity

On leaving the factory, the device was in perfect condition from the point of view of safety. It complies with the standards EN 61010 -1 “Protection Measures for Electrical Equipment for Measurement, Control, Regulation and Laboratory Procedures” and with the EMC requirements of IEC/EN 61326. The device meets the legal requirements of the EU Directives. The manufacturer confirms a positive completion of all tests by fitting the unit with a CE mark.

Hygiene standard

The TTR35 temperature switch meets the requirements of Sanitary Standard no. 74-06. Endress+Hauser confirms this by applying the 3-A symbol (not valid for process connection conical metal-metal).

UL listed for Canada and USA

The device was examined by Underwriters Laboratories Inc. (UL) in accordance with the standards UL 61010B-1 and CSA C22.2 No. 1010.1-92 and listed under the number E225237 UL.

3 Installation

3.1 Incoming acceptance, storage

- Incoming acceptance:
 - Check the packaging and the device for damage. Check that the goods delivered are complete and nothing is missing.
- Storage: Storage temperature $-40\text{ }^{\circ}\text{C}$ to $+85\text{ }^{\circ}\text{C}$ ($-40\text{ }^{\circ}\text{F}$ to $+185\text{ }^{\circ}\text{F}$)

3.2 Dimensions

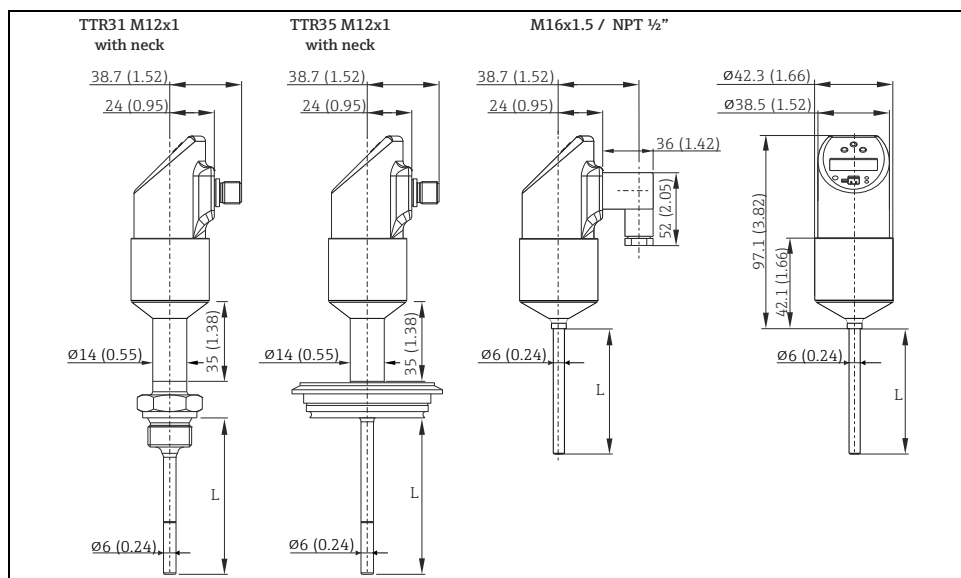

A0023288-EN

Fig. 2: Dimensions in mm (in)

L = Insertion length

M12x1 connector as per IEC 60947-5-2

M16x1.5 or NPT 1/2" valve plug as per DIN 43650A/ISO 4400

3.3 Process connection

3.3.1 TTR31 design, dimensions of the process connections

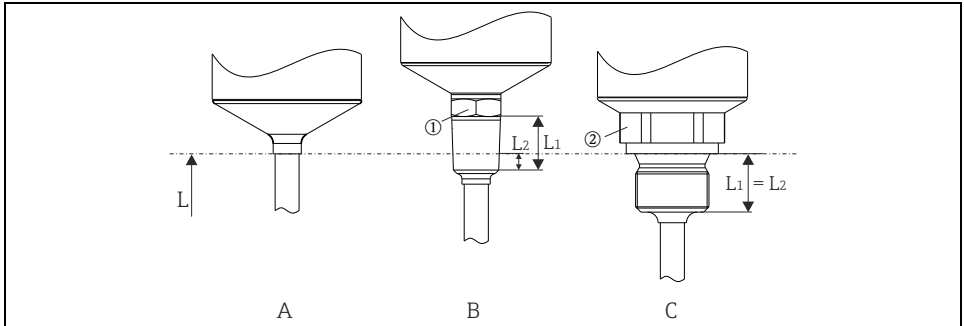

Fig. 3: Process connection versions of TTR31

A0007101

L = Insertion length

Item no.	Version	Thread length L_1	Thread length L_2
A	Without process connection. For suitable welding boss and coupling see chapter 'Accessories'.	-	-
B	Thread process connection: <ul style="list-style-type: none"> ■ ANSI NPT ¼" (① = AF14) ■ ANSI NPT ½" (① = AF27) 	<ul style="list-style-type: none"> ■ 14.3 mm (0.56 in) ■ 19 mm (0.75 in) 	<ul style="list-style-type: none"> ■ 5.8 mm (0.23 in) ■ 8.1 mm (0.32 in)
C	Thread process connection cylindrical as per ISO 228: <ul style="list-style-type: none"> ■ G¼" (② = AF14) ■ G½" (② = AF27) 	<ul style="list-style-type: none"> ■ 12 mm (0.47 in) ■ 14 mm (0.55 in) 	-

3.3.2 TTR35 design, dimensions of the process connections

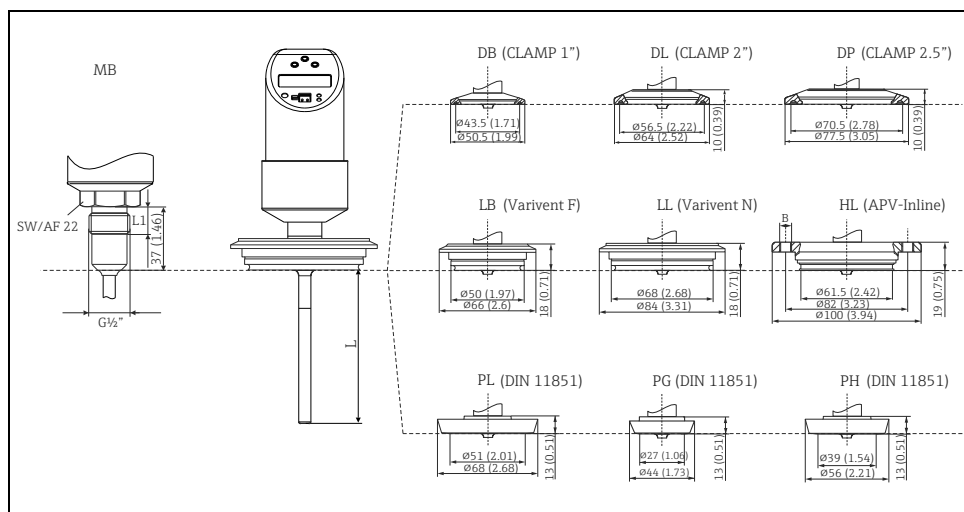

Fig. 4: All dimensions in mm (in)

L = Insertion length L

A0023235

Item no.	Process connection versions TTR35
MB	Conical metal-metal for hygienic processes, G $\frac{1}{2}$ " thread, thread length L ₁ = 14 mm (0.55 in). Suitable welding boss available as accessory.
DB	Clamp 1"...1 $\frac{1}{2}$ " (ISO 2852) or DN 25...DN 40 (DIN 32676)
DL	Clamp 2" (ISO 2852) or DN 50 (DIN 32676)
DP	Clamp 2 $\frac{1}{2}$ " (ISO 2852)
LB	Varivent ¹⁾ F DN25-32, PN 40
LL	Varivent ¹⁾ N DN40-162, PN 40
HL	APV-Inline, DN50, PN40, 316L, B = bores 6 x $\varnothing 8.6$ (0.34 in) + 2 x thread M8
PL	DIN 11851, DN50, PN40 (including coupling nut)
PG	DIN 11851, DN25, PN40 (including coupling nut)
PH	DIN 11851, DN40, PN40 (including coupling nut)

- 1) Varivent® process connections are suitable for installation in VARINLINE® housing connection flanges

NOTICE

The maximum process pressure for the conical metal-metal process connection (Fig. 4, item MB) is 16 bar = 1.6 MPa (232 psi).

3.4 Installation instructions

NOTICE

Do not thread into process connection by turning the housing. Always use a wrench (see table, → 8) on the process connection flats (→ Fig. 5, Pos. 1) to tighten the sensor into the process connection.

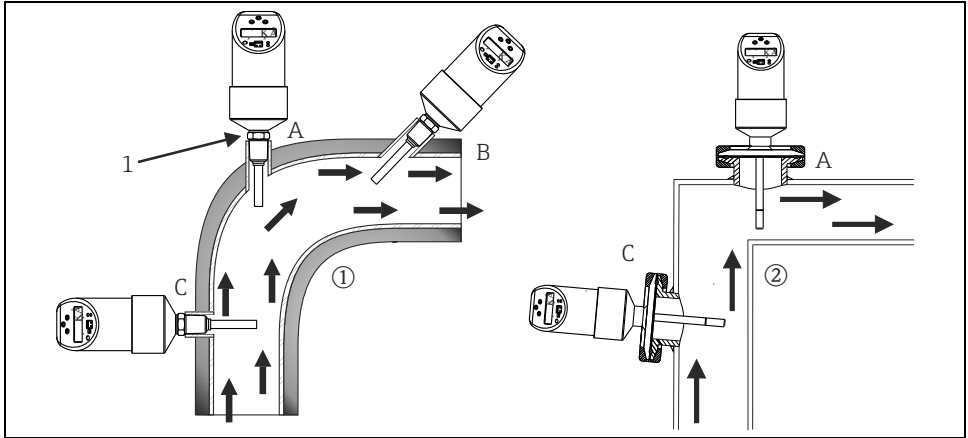

Fig. 5: Possible installation options for temperature monitoring in pipes

A0011644

© TTR31

© TTR35 for use in hygienic processes

General mounting instructions:

- Installation at angle pieces, against the direction of flow (→ Fig. 5, Item A).
- Installation in smaller pipes, inclined against the direction of flow (→ Fig. 5, Item B).
- Installation vertical to the direction of flow (→ Fig. 5, Item C). Installation of TTR35 by min. 3° inclination, because of self draining.
- The on-site display can be rotated electronically 180° – see Section 5.1 “On-site operation”.
- The housing can be rotated up to 310°.

Mounting instructions for installation in hygienic processes:

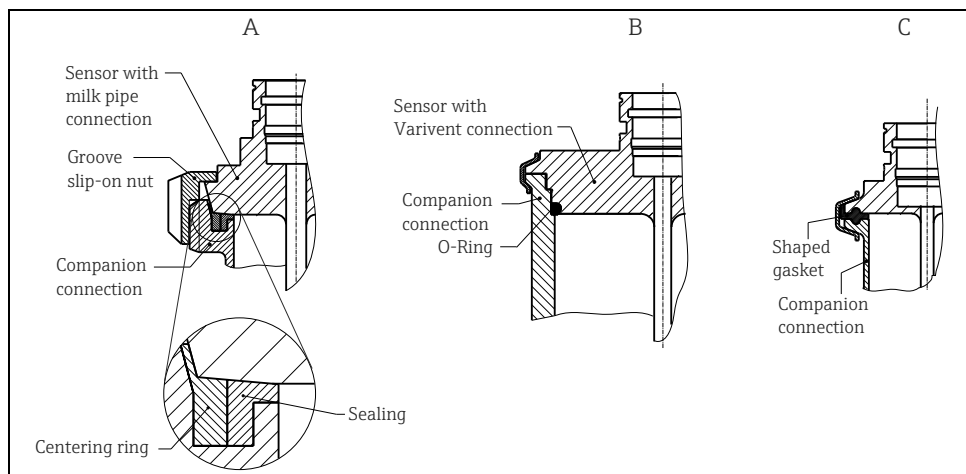

A0011673-EN

Fig. 6: Installation in hygienic processes

- A Milk pipe connection as per DIN 11851 (connection PL, PG, PH), only in linkage with EHEDG certified and self centering ring
- B Varivent and APV-Inline (connection LB, LL, HL)
- C Clamp as per ISO 2852 (connection DB, DL, DP)

4 Wiring

NOTICE

TTR35: Electrical cables must comply with 3-A standard. They must be smooth, corrosion resistant and cleanable.

4.1 DC voltage version with M12x1 connector

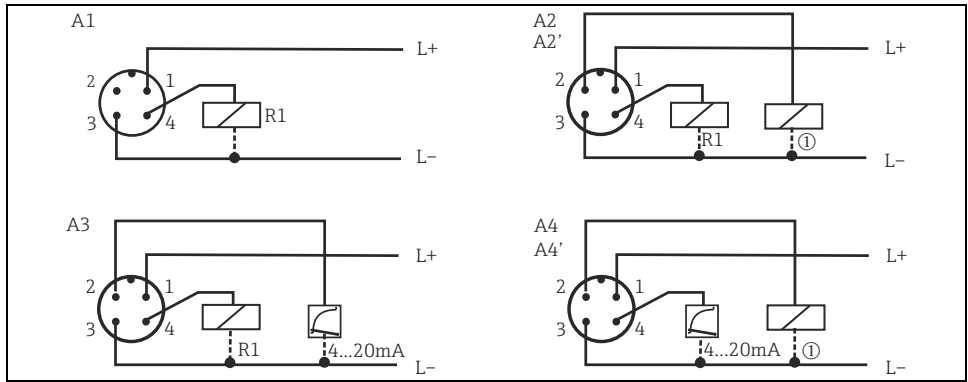

Thermophant T with M12x1 connector

A1: 1x PNP switch output

A2: 2x PNP switch outputs R1 and Ⓞ (R2)

A2': 2x PNP switch outputs R1 and Ⓞ (diagnosis/break contact with adjustment "DESINA")

A3: 1x PNP switch output and 1x analog output (4 to 20 mA)

A4: 1x analog output (4 to 20 mA) and 1x PNP switch output Ⓞ (R2)

A4': 1x analog output (4 to 20 mA) and 1x PNP switch output Ⓞ
(diagnosis/break contact with adjustment "DESINA")

NOTICE

To avoid the analog input damaging of a PLC, do not connect the active PNP switch output of the device to the 4...20 mA input of a PLC.



More informations about DESINA see www.desina.de (→ 17 Basic settings).

4.2 DC voltage version with valve connector

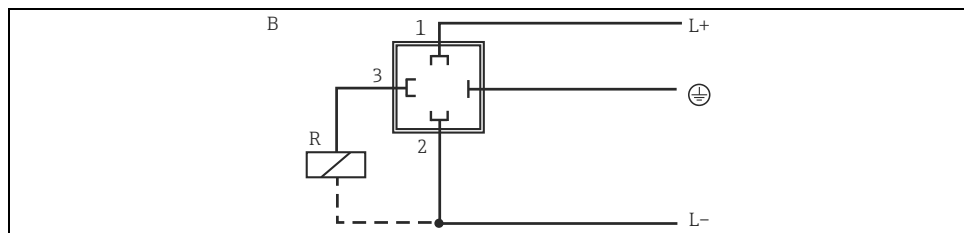

Thermophant T with M 16x1.5 or NPT ½" valve plug

B: 1x PNP switch output

A0023449

5 Operation

5.1 On-site operation

The Thermophant T is operated by means of three keys. The digital display and the light emitting diodes (LED) support navigation in the operating menu.

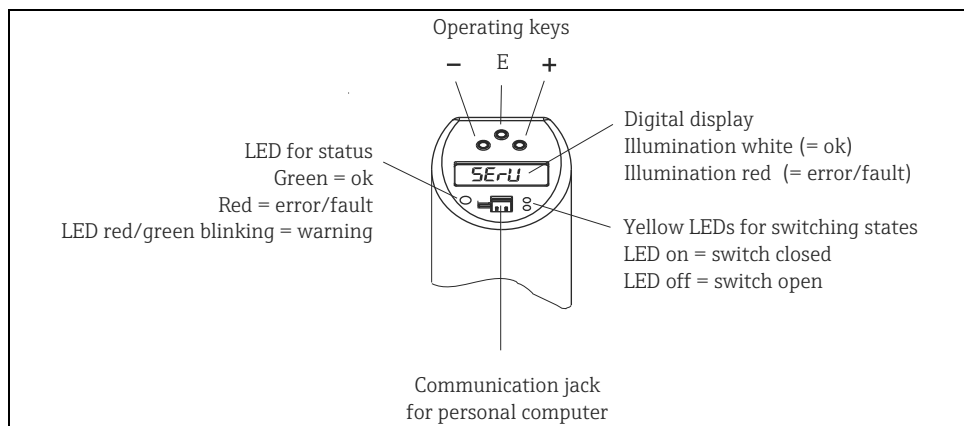

Fig. 7: Position of operating elements and possibilities for display

A0020825-EN

5.1.1 Navigating in the operating menu

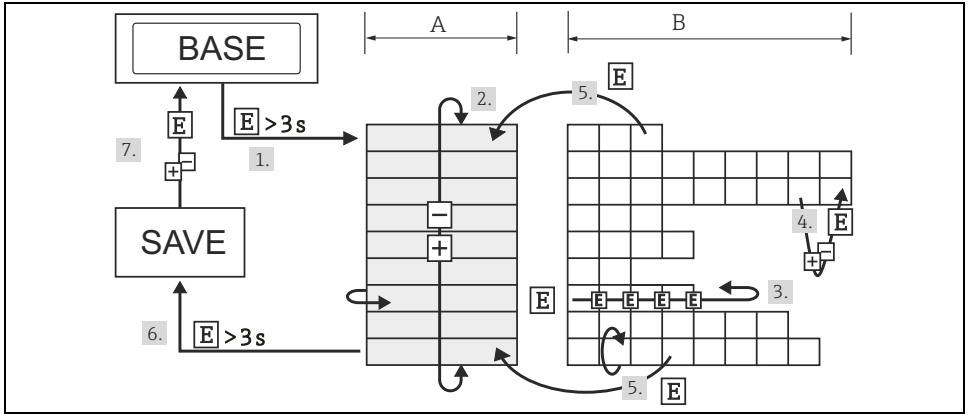

Fig. 8: Navigating in the operating menu

A0023337

A Function group selection

B Function selection

1. Enter the operating menu
Press the E key for longer than 3 s
2. Select the “Function group” with the + or - key
3. Select the “Function” with the E key
4. Enter or change parameters with the + or - key
Then return to “Function” with the E key
Note: If software locking is enabled, it must be disabled before making entries or changes
5. Press the E key several times to return to the “Function group”
- until the appropriate function group is reached again
6. Jump back to the measuring position (Home position)
- press the E key for longer than 3 s
7. Query to save data (select “YES” or “NO” with the + or - key)
- confirm with the E key



Changes to the parameter settings only become effective if you choose 'YES' when asked to save data.

5.1.2 Structure of the operating menu for 1x or 2x switch outputs

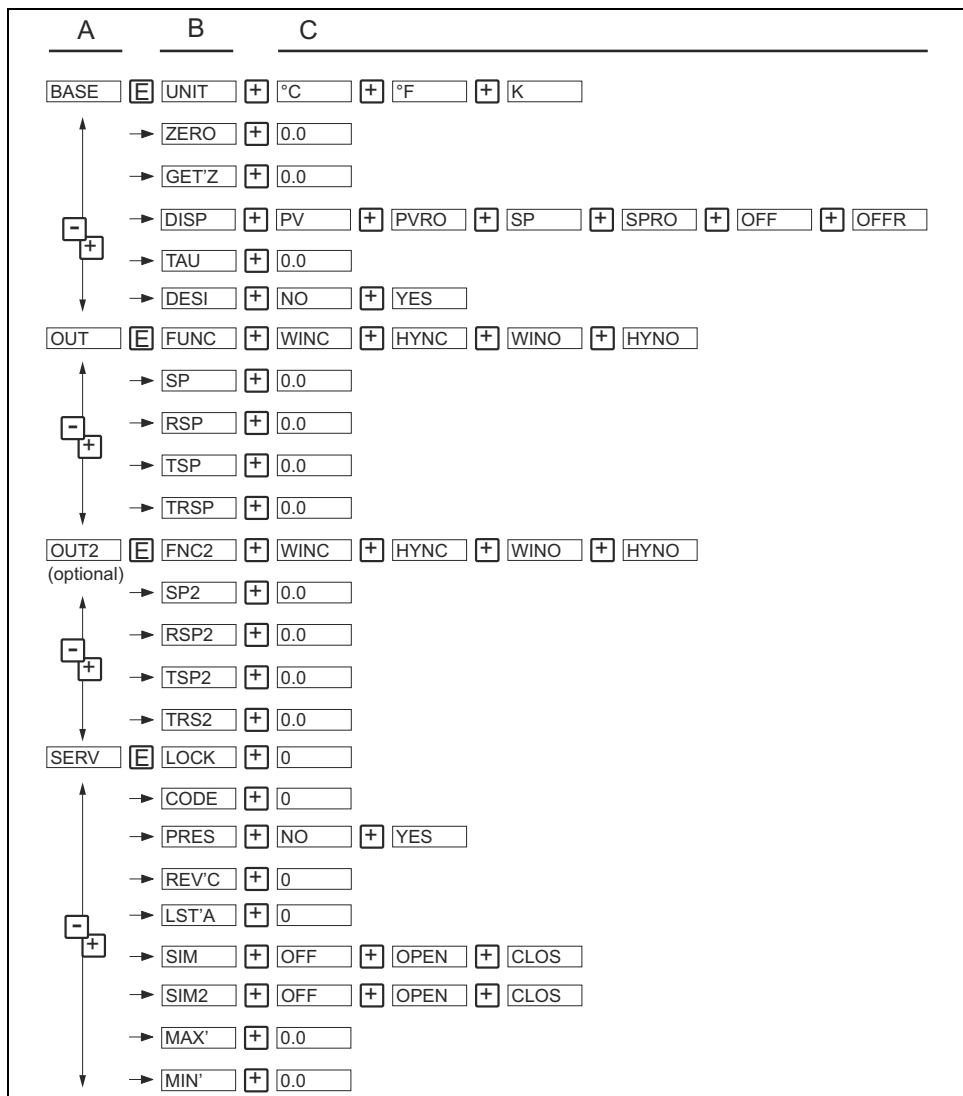

Fig. 9: Operating menu: A function groups, B functions, C settings

A0008102

5.1.3 Structure of the operating menu for 1x switch output or 1x analog output (4 to 20 mA)

At devices with analog output both output 1 and output 2 can be configured as an analog output. Furthermore it is possible to configure both output 1 and output 2 as a switch output.

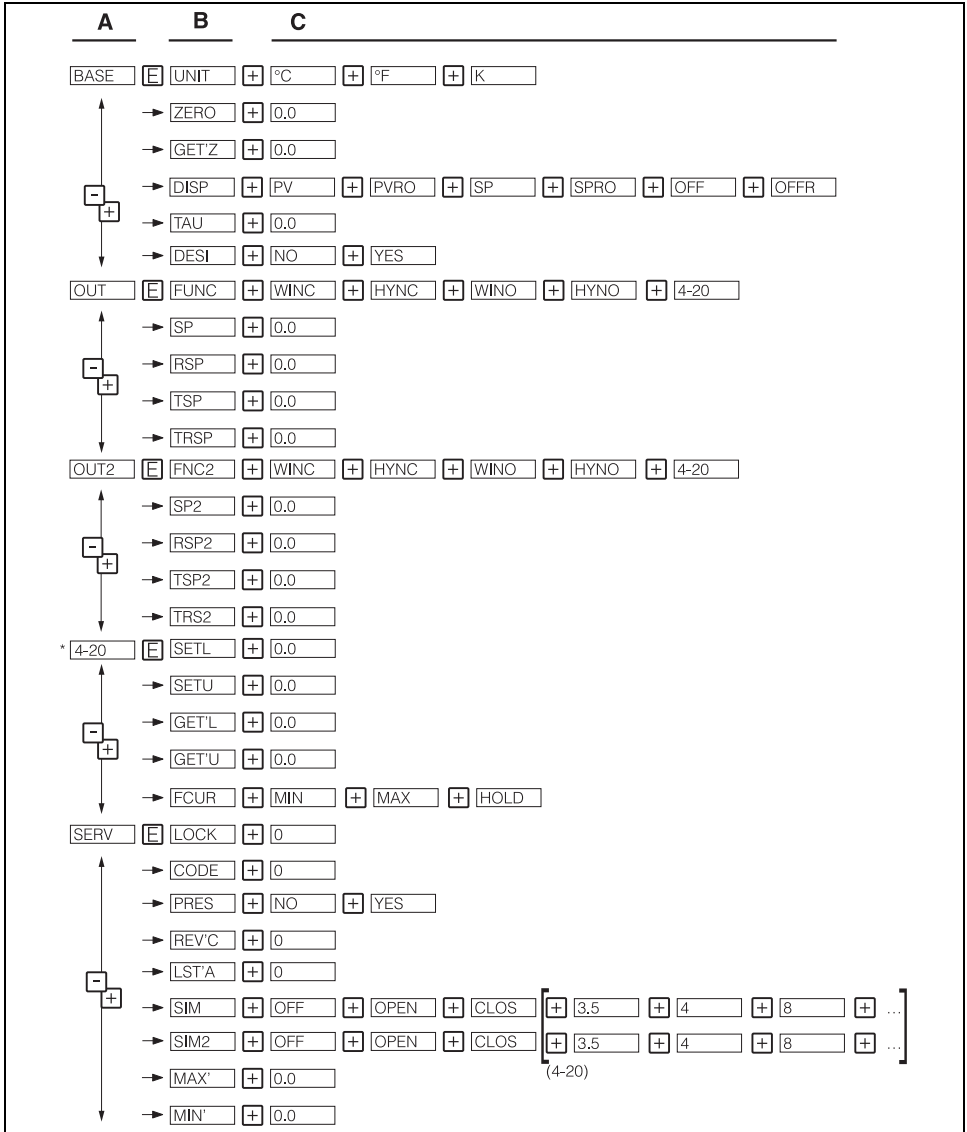

Fig. 10: Operating menu: A function groups, B functions, C settings

A0008103

5.1.4 Basic settings



The function group 4-20 is only available if the 4 to 20 mA analog output (4--20) is selected in the function group OUT or OUT2 under FUNC or FNC2.

Function group	Function		Settings	Description
BASE	UNIT	Technical unit	°C °F K	Select technical unit: °C, °F, K Factory setting: °C
	ZERO	Configure zero point	0.0	Position adjustment: within ±10 °C/K (±18 °F) of the upper range limit
	GET'Z	Accept zero point	0.0	No settings possible (not available in PC software)
	DISP	Display	PV PVRO SP SPRO OFF OFFR	PV: measured value display PVRO: measured value display rotated 180° SP: set switch point display SPRO: set switch point display rotated 180° OFF: display off OFFR: display off rotated 180° Factory setting: measured value (PV)
	TAU	Damping: display value, output signal	0.0	Measured value damping with regard to display value and output: 0 (no damping) or 9 to 40 s (in increments of 1 second) Factory setting: 0 s
BASE	DESI	DESINA	NO YES	PIN assignment of the M12 connector is in accordance with the guidelines of DESINA Factory setting: NO Configuration DESINA is only possible, if output 1 and output 2 are selected.

5.1.5 Settings for output - 2x switch output

- Hysteresis function
The hysteresis function enables two-point control via a hysteresis. Depending on the temperature T, the hysteresis can be set via the switch point SP and the switch-back point RSP.
- Window function
The window function enables the monitoring of a process temperature range.
- NO contact or NC contact
This switch function is freely selectable.
- Delay times for switch point SP and switch-back point can be set in increments of 1 s. By this means undesirable temperature peaks of short duration or of high frequency can be filtered out.
- Factory setting (if no customer-specific settings have been ordered):
Switch point SP 1: 45 °C (113.0 °F); Switch-back point RSP 1: 44.5 °C (112.1 °F)
Switch point SP 2: 55 °C (131.0 °F); Switch-back point RSP 2: 54.5 °C (130.1 °F)
- Range of adjustment
LRL = Lower Range Limit
URL = Upper Range Limit
LRV = Lower Range Value
URV = Upper Range Value

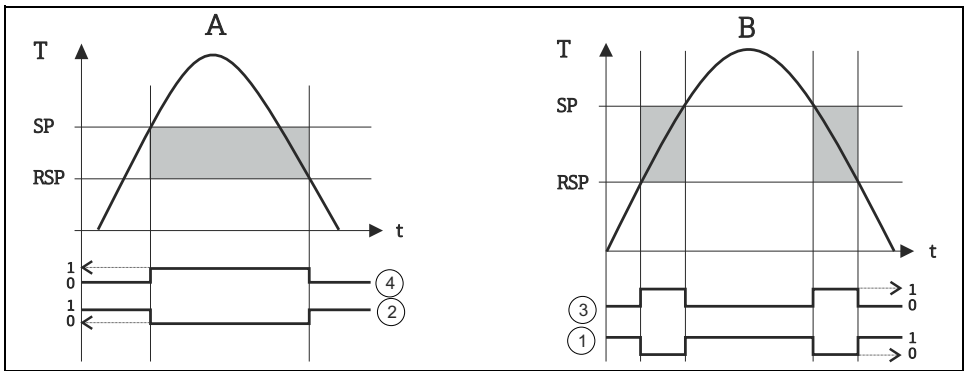

Fig. 11: Switch point functions

A0023240

Pos. A: Hysteresis-function

Pos. B: Window-function

① Window - NC contact

② Hysteresis - NC contact

③ Window - NO contact

④ Hysteresis - NO contact

SP switch point; RSP switch-back point

Function group	Function		Settings	Description
OUT Output 1 OUT2 Output 2, as option	FUNC FNC2	Switching characteristic	WINC HYNC WIND HYNO	WINC : window/NC contact HYNC : hysteresis/NC contact WIND : window/NO contact HYNO : hysteresis/NO contact Factory setting: HYNO
	SP SP2	Switch point value	0.0	Switch point -49.5 to 150 °C (-57.1 to 302 °F) in increments of 0.1 °C (0.18 °F)
OUT Output 1 OUT2 Output 2, as option	RSP RSP2	Switch-back point value	0.0	Switch-back point -50 to 149 °C (-58 to 300 °F) in increments of 0.1 °C (0.18 °F)
	TSP TSP2	Switch point delay	0.0	Delay time 0...99 s in increments of 0.1 s Factory setting: 0 s
	TRSP TRSP2	Switch-back point delay	0.0	Delay time 0...99 s in increments of 0.1 s Factory setting: 0 s
Min. distance between SP and RSP: 0.5 °C/K (0.9 °F)				

5.1.6 Settings for output - 1x switch output and 1x analog output (4 to 20 mA)

Function group	Function		Settings	Description
OUT Output 1 OUT2 Output 2, as option	FUNC FNC2	Switching characteristic	WINC HYNC WIND HYNO 4--20	WINC: window/NC contact HYNC: hysteresis/NC contact WIND: window/NO contact HYNO: hysteresis/NO contact 4 - 20: analog output Factory setting: HYNO
	SP SP2	Switch point value	0.0	Switch point -49.5 to 150 °C (-57.1 to 302 °F) in increments of 0.1 °C (0.18 °F)
OUT Output 1 OUT2 Output 2, as option	RSP RSP2	Switch-back point value	0.0	Switch-back point -50 to 149 °C (-58 to 300 °F) in increments of 0.1 °C (0.18 °F)
	TSP TSP2	Switch point delay	0.0	Delay time 0...99 s in increments of 0.1 s Factory setting: 0 s
	TRSP TRSP2	Switch-back point delay	0.0	Delay time 0...99 s in increments of 0.1 s Factory setting: 0 s

Function group	Function		Settings	Description
Min. distance between SP and RSP: 0.5 °C/K (0.9 °F)				
4--20 Analog output	SETL	Value for 4 mA (LRV)	0.0	-50 to 130 °C (-58 to 266 °F) Lower range value in increments of 0.1 °C (0.18 °F) Factory setting: 0.0 °C (32.0 °F)
	SETU	Value for 20 mA (URV)	0.0	-30 to 150 °C (-22 to 302 °F) Enter upper range value in increments of 0.1 °C (0.18 °F) Factory setting: 150 °C (302 °F)
	GET'L	Temperature applied for 4 mA (LRV)	0.0	Take temperature value as lower range value (not via PC software)
	GET'U	Temperature applied for 20 mA (URV)	0.0	Take temperature value as upper range value (not via PC software)
	FCUR	Error current	MIN MAX HOLD	Current value in event of error: MIN = ≤ 3.6 mA MAX = ≥ 21.0 mA HOLD = last value Factory setting: MAX
Min. distance between SETL and SETU: 20 °C/K (36 °F)				



The function group (4--20) is only available if the 4 to 20 mA analog output (4--20) is selected in the function group *OUT* or *OUT2* under *FUNC* or *FUNC2*.

5.1.7 Settings for service functions

Function group	Function		Settings	Description
SERV Service functions	LOCK	Locking code	0	Enter the locking code for enabling the device.
	CODE	Change locking code	0	Freely selectable code 1...9999. 0 = no locking; A locking code already assigned can only be changed by first entering the old code for enabling the device.
	PRES	Reset	NO YES	Reset all entries to the factory setting
	REV' C	Revision counter	0	Increases by 1 with each configuration
	LST' A	Last device status	0	Displays the last device status to occur ≠ 0
SERV Service functions	SIM SIM2 (if output 2 available)	Simulation output 1 or 2	OFF OPEN CLOS 3.5 (if analog output available)	OFF: No simulation OPEN: Switch output open CLOS: Switch output closed 3.5: Simulation values for analog output in mA (3.5/4.0/8.0/12.0/ 16.0/20.0/21.7)
	MAX'	Max. indicator	0.0	Display of max. measured process value
	MIN'	Min. indicator	0.0	Display of min. measured process value

5.2 Operation with PC

The device can be configured with the configuration software ReadWin 2000 or FieldCare. For the connection between the USB port of the computer and the device a configuration kit (e.g. TXU10-AA) is necessary.

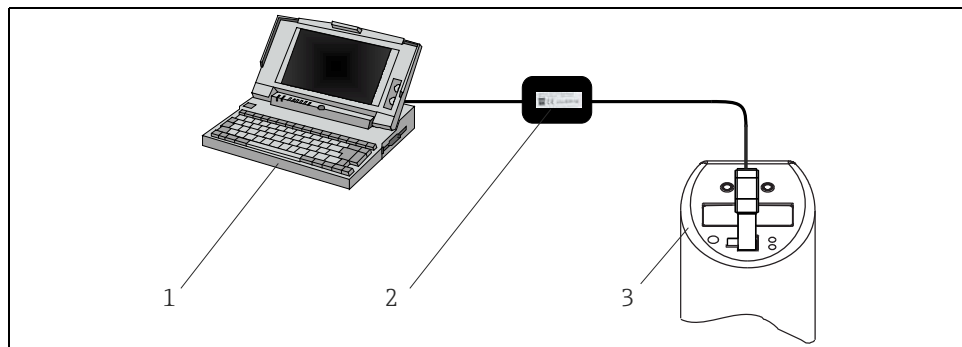

Fig. 12: Operation with PC

A0008072

Item 1: PC with configuration software ReadWin 2000 or FieldCare

Item 2: Configuration kit TXU10-AA or FXA291

Item 3: Temperature switch

5.2.1 Additional operating options

In addition to the operating options listed in the previous “On-site operation” section, the ReadWin 2000 or FieldCare configuration software provides further information on the Thermophant T:

Function group	Description
SEFV'	Number of switch changes for output 1
	Number of switch changes for output 2
	Device status

Function group	Description
INFO	Tag number
	Order code
	Limit switch serial number
	Sensor serial number
	Electronics serial number
	Device release (change status)
	Hardware version
	Software version

5.2.2 Hints for the configuration with Readwin 2000

Comprehensive information on the ReadWin 2000 configuration software may be found in the Operating Instructions BA137R/09/en.

5.2.3 Hints for the configuration with FieldCare

FieldCare is an universal configuration software based on FDT/DTM technology.



- To configure the Thermophant T TTR31/35 with FieldCare the “PCP (ReadWin) Communication DTM” and the Thermophant Device-DTM are required.
- All devices with software version 1.01.00 or higher can be configured with FieldCare.
- The device supports only offline configuration and up-/download of parameters. The online configuration is not supported.

Detailed information concerning FieldCare may be found in the operation manual (BA027S/c4) or see: www.endress.com.

6 Maintenance

Any buildup on the sensor can have a negative effect on the sensor response time. For this reason, check the sensor for buildup at regular intervals.

⚠ CAUTION

Make sure the process is unpressurized before you remove the device! Do not twist the device out of the process connection thread at the housing. Always use a suitable open-ended wrench for disassembly work (→ Chap. 3.3 and → Fig. 5)

7 Accessories

Various accessories, which can be ordered with the device or subsequently from Endress+Hauser, are available for the device. Detailed information on the order code in question is available from your local Endress+Hauser sales center or on the product page of the Endress+Hauser website: www.endress.com

If ordering accessories, please specify the serial number of the unit! All dimensions in the drawings are given in mm (in).

7.1 Welding bosses and coupling

7.1.1 Welding boss with sealing taper

Collar welding boss moveable with sealing taper and pressure screw; material of parts in contact with the process: 316L, PEEK, max. process pressure 10 bar (145 psi)
Order number: 51004751

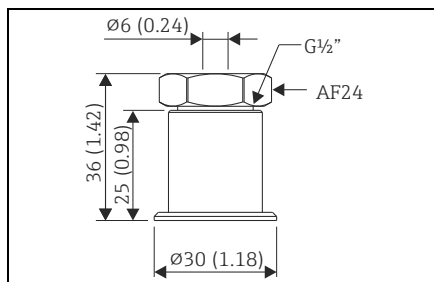

A0020709-EN

7.1.2 Collar welding boss

Material of parts in contact with process:
 316L
 Order no. 51004752

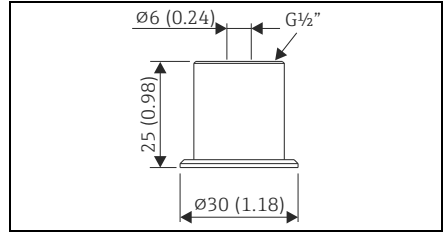

A0020710

7.1.3 Welding boss with sealing taper (metal-metal)

Welding boss
 Seal, metal-metal,
 Material of parts in contact with process:
 316L
 Max. process pressure 16 bar (232 psi)
 Order no. 60021387

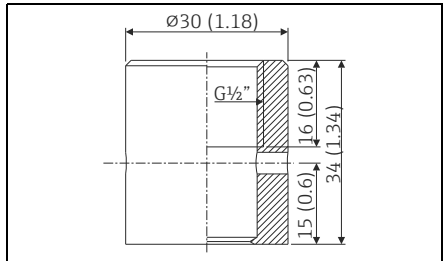

A0006621

7.1.4 Coupling

Moveable coupling, G $\frac{1}{2}$ " process connection,
 coupling and parts in contact with process:
 316L
 Order no. 51004753

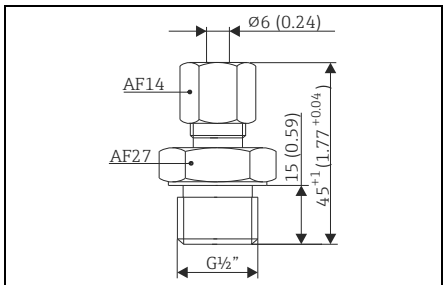

A0020174-EN

7.2 Electrical connection

7.2.1 Plug-in jack; connecting cable

Coupling M12x1 for simple user installable assembly of the connecting cable; straight; connection to M12x1 housing connector IP67

Order number: 52006263

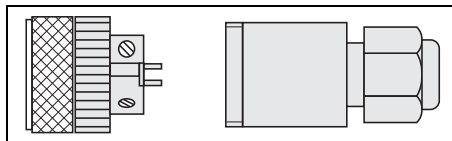

P01-PMP13cax-00-xx-00-xx-003

Coupling M12x1 for simple user installable assembly of the connecting cable; elbowed; connection to M12x1 housing connector IP67

Order number: 51006327

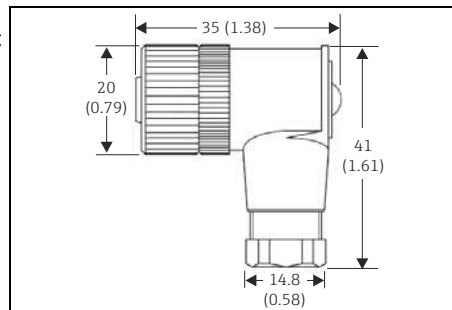

A0020722

PVC cable (preassembled), 4 x 0.34 mm² (22 AWG) with M12x1 coupling, elbowed, screw plug, length 5 m (16.4 ft), IP 67

Order number: 51005148

Core colours:

- 1 = BN brown
- 2 = WH white
- 3 = BU blue
- 4 = BK black

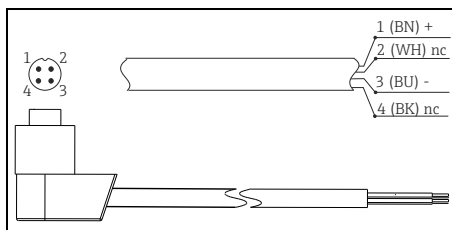

A0020723

PVC cable (preassembled), 4 x 0.34 mm² (22 AWG) with M12x1 coupling, with LED, elbowed, 316L screw plug, length 5 m (16.4 ft), specially for hygiene applications, IP69K

Order number: 52018763

Display:

- gn: device operational
- ye1: switch status 1
- ye2: switch status 2

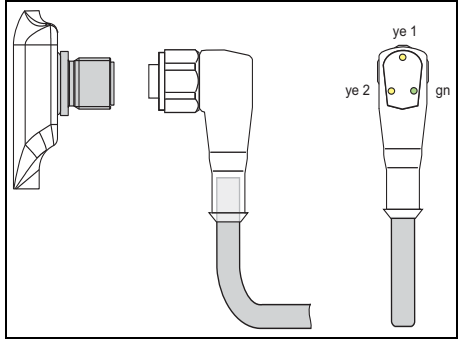

T09-TTR3 1xxx-00-00-xx-xx-001



Not for use at devices with “4 to 20 mA analog output” option.

7.3 Configuration kit

- Configuration kit for PC-programmable transmitters - ReadWin 2000 setup program and interface cable for PCs with USB port and 4-pole post connector
Order code: **TXU10-AA**
- Configuration kit “Commbobox FXA291” with interface cable for PCs with USB port. Intrinsically safe CDI interface (Endress+Hauser Common Data Interface) for transmitters with 4-pole post connector. Suitable device configuration tool is e.g. FieldCare.
Order code: **FXA291**

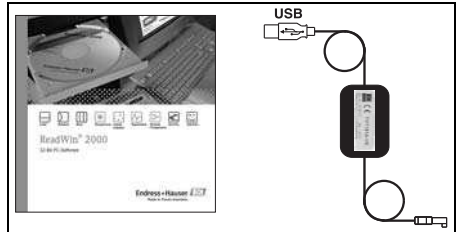

A0008067

7.4 Configuration software

ReadWin 2000 and FieldCare 'Device Setup' can be downloaded free of charge directly from the internet at the following addresses:

- www.endress.com/readwin
- www.products.endress.com/fieldcare

For the order of the FieldCare 'Device Setup' software please ask your Endress+Hauser sales organization.

8 Trouble-shooting

8.1 Errors and warnings

If an error in the device occurs, the colour of the status LED changes from green to red and the digital display illumination changes from white to red. A status LED flashing red and green signals a warning. The display shows:

- E-code for errors
In the event of an error message, the measured value is uncertain.
- W-code for warnings
In the event of a warning, the measured value is reliable.

Code	Explanation	Remedy
E011	Device configuration faulty	Reset device (→ 22)
E012	Error in measurement or medium temperature outside specification	Check medium temperature, return device to E+H where necessary
E019	Power supply outside specification	Check operating voltage
E015	Memory error	Return device to E+H
E020		
E021		
E022	Power is only supplied to the device via the communication interface (measurement is deactivated)	Check operating voltage
E025	Switching contact 1 is not open although it should be	Switching contact defective, return device to E+H
E026	Switching contact 2 is not open although it should be	Switching contact defective, return device to E+H
E040	VCC (Controller voltage) is out of working area	Return device to E+H
E042	Output current can no longer be generated (only for 4 to 20 mA output, e.g. load at analog output too high or open analog output)	Check load. Switch off analog output via configuration, if it isn't required, → 20.
E044	Output current drifts too much (± 0.5 mA)	Return device to E+H

Code	Explanation	Remedy
W107	Simulation active	Switch off the output simulation for output 1 and output 2
W202	Measured value outside of the sensor range	Operate the device in the specified temperature range
W209	Device starts	
W210	Configuration modified (warning code will be displayed for 15 s approx.)	
W212	Sensor signal outside the permitted range	Operate the device in the specified temperature range
W250	Number of switch cycles exceeded	Replace the device
W270	Short-circuit or overload at output 1	Check output wiring. Extend the load resistance at output 1
W280	Short-circuit or overload at output 2	Check output wiring. Extend the load resistance at output 2

8.2 Repair

A repair is not planned.

8.3 Disposal

Please pay particular attention to the local disposal regulations of your country. When disposing, ensure that the materials of the device components are separated and processed accordingly.

8.4 Software history and compatibility overview

The release number on the nameplate and in the Operating Instructions indicates the change status of the device: XX.YY.ZZ (example 01.02.01).

XX	Change in the main version. Compatibility no longer provided. Device and Operating Instructions change.
YY	Change in functionality and operation. Compatibility provided. Operating Instructions change.
ZZ	Trouble-shooting and internal modifications. Operating Instructions do not change.

Software history

Date	Release no. device	Changes in software	Documentation
06.2004	01.00.00		KA174r/09/en (51008032)
12.2004	01.01.00	New analog electronics	BA201r/09/en/02.05 (51009833)
02.2005	01.02.00	Internal	BA201r/09/en/02.05 (51009833)
02.2006	01.02.01	Parameter functional safety for the optional analog output is not applicable	BA229r/09/en/03.06 (71025405)
02.2006	01.02	-	BA229r/09/en/01.08 (71025405)
02.2006	01.02	-	BA229r/09/en/06.09 (71098142)
04.2014	01.02	-	BA00229R/EN/13.14 (71252258)

9 Technical data

9.1 Power supply

Supply voltage

- DC voltage version 12...30 V DC

Current consumption

- Without load < 60 mA, with reverse polarity protection

Power supply failure

- Behaviour in case of overvoltage ($> 30\text{ V}$)
The device works continuously up to 34 V DC without any damage. No damage is caused to the device in case of a short-term overvoltage up to 1 kV (as per IEC 61000-4-5). If the supply voltage is exceeded, the properties specified are no longer guaranteed.
- Behaviour in case of undervoltage
If the supply voltage drops below the minimum value, the device switches off (status as if not supplied with power = switch open).

9.2 Output

Switching capacity

- Switch status ON: $I_a \leq 250\text{ mA}$
- Switch status OFF: $I_a \leq 1\text{ mA}$
- Switching cycles: $> 10,000,000$
- Voltage drop PNP: $\leq 2\text{ V}$
- Overload protection
Automatic load testing of switching current; output is switched off in case of overcurrent, the switching current is tested again every 0.5 s ; max. capacitance load: $14\text{ }\mu\text{F}$ for max. supply voltage (without resistive load).

Load (analog output)

- Max. $(V_{\text{supply}} - 6.5\text{ V}) / 0.022\text{ A}$

Signal on alarm

- Analog output: $\leq 3.6\text{ mA}$ ('MIN') or $\geq 21.0\text{ mA}$ ('MAX') adjustable¹⁾
- Switch outputs: in safe state (switch normally open)

9.3 Operating conditions

- Any orientation
- Any position-dependent zero shift can be corrected; Offset: $\pm 20\%$ URL

9.3.1 Environment

- Ambient temperature range: $-40\dots+85\text{ }^\circ\text{C}$ ($-40\dots+185\text{ }^\circ\text{F}$)
- Storage temperature: $-40\dots+85\text{ }^\circ\text{C}$ ($-40\dots+185\text{ }^\circ\text{F}$)
- Degree of protection: IP65 (optional IP66, depending on used connector)

9.3.2 Process

Process temperature limits

- $-50\text{ to }150\text{ }^\circ\text{C}$ ($-58\text{ to }302\text{ }^\circ\text{F}$) generally,
- $-50\text{ to }200\text{ }^\circ\text{C}$ ($-58\text{ to }392\text{ }^\circ\text{F}$) version TTR35 with neck

1) Guaranteed value for setting 'MAX': $\geq 21.6\text{ mA}$



Restrictions depending on process connection and ambient temperature.

- No restriction with coupling (see Accessories, → 25, → 26, order no. **51004751**, **51004753**) and neck tube length min. 20 mm (0.79 in).
- With process connection:

Max. ambient temperature	Max. process temperature
up to 25 °C (77 °F)	no restriction
up to 40 °C (104 °F)	135 °C (275 °F)
up to 60 °C (140 °F)	120 °C (248 °F)
up to 85 °C (185 °F)	100 °C (212 °F)

Process pressure limits

Maximum permitted process pressure depending on the insertion length.

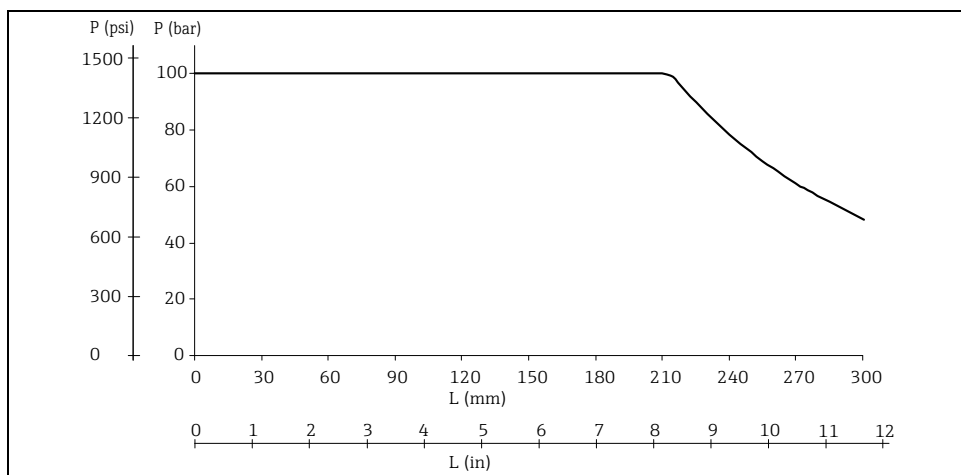

Fig. 13: Maximum permitted process pressure

L = insertion length
 p = process pressure

The diagram takes into consideration not only the overpressure but also the pressure load caused by the flow, whereby a safety factor of 1.9 has been specified for operation with flow. The maximum permitted static operating pressure is lower at greater insertion lengths due to the increased bending load caused by the flow. The calculation assumes the maximum permitted medium velocity for the respective insertion length (see diagram below).

NOTICE

The maximum process pressure for the conical metal-metal process connection (see Fig. 4, item MB) is 16 bar = 1.6 MPa (232 psi).

Permitted flow velocity depending on the insertion length.

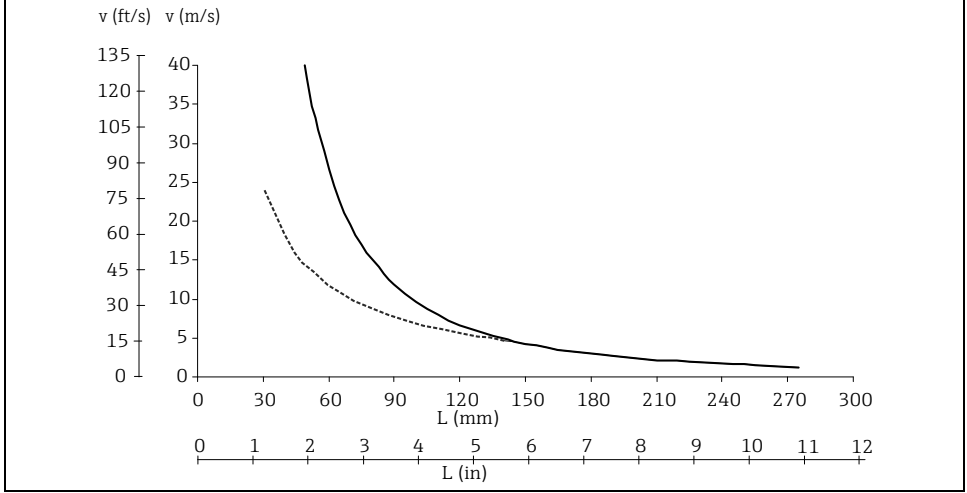

Fig. 14: Permitted flow velocity

L = insertion length, during flow
 v = flow velocity
Medium: ----- air; - - - - - water

The permitted flow velocity is the minimum from resonance velocity (resonance distance 80%) and load or buckling caused by flow, which would lead to failure of the thermometer tube or to exceedance of the safety factor (1.9). Calculation was performed for the specified limit operating conditions of 200 °C (392 °F) and ≤ 10 MPa (1450 PSI) process pressure.

10 Dangerous good sheet

Declaration of Decontamination

Because of legal regulations and for the safety of our employees and operating equipment, we need the "declaration of decontamination", with your signature, before your order can be handled. Please make absolutely sure to include it with the shipping documents, or - even better - attach it to the outside of the packaging.

Please return your products to:

Please direct your inquiry to local Endress+Hauser sales representative.

Type of instrument/sensor: _____ Serial number: _____

Used as SIL device (Safety Integrity Level) in a Safety Instrument System

Process data: Temperature: _____ [°C] Pressure: _____ [bar]
Conductivity: _____ [S] Viscosity: _____ [mm²/s]

Medium and warnings:







	Medium/ Concentration	flammable	toxic	corrosive	harmful/ irritant	other*	harmless
Process medium							
Medium for process cleaning							
Returned part cleaned with							

Please tick should one of the above be applicable, include security sheet and, if necessary, special handling instructions. *e.g. explosive; oxidizing; dangerous for the environment; biological risk; radioactive

Reason for return: _____

Company data:

Company: _____ Phone number: _____

Contact person: _____ Fax: _____

Address: _____ E-Mail: _____

_____ Your order No.: _____

We hereby certify that the returned parts have been carefully cleaned. To the best of our knowledge they are free from any residues in dangerous quantities.

Place, date _____ Company stamp and legally binding signature _____

www.addresses.endress.com
