



Füllstand



Druck



Durchfluss



Temperatur



Flüssigkeits-  
analyse



Registrierung



Systeme  
Komponenten



Services



Solutions

## Operating Instructions

# Liquicap M FMI51, FMI52 FEI57C PFM

## Capacitance level measurement

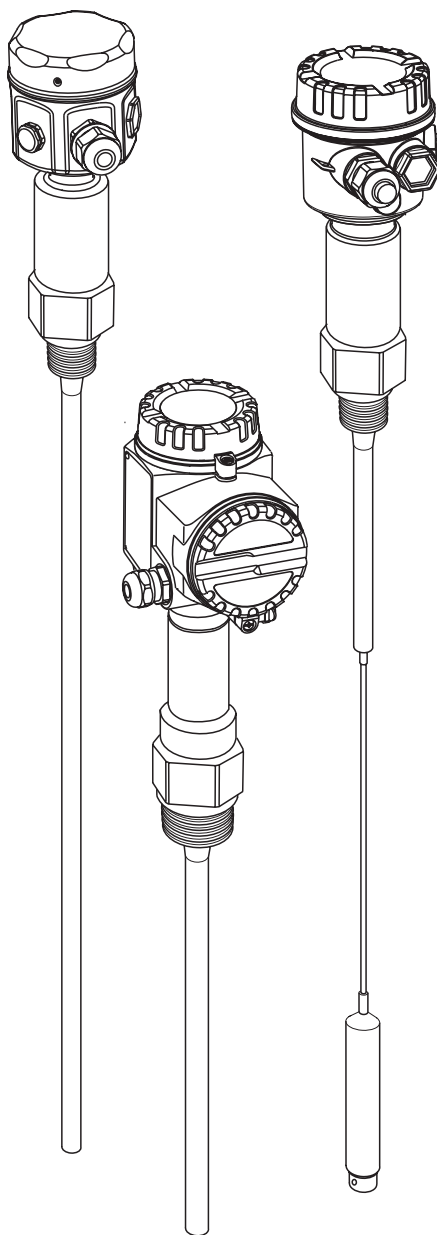

BA00297F/00/EN/13.10  
71128821

Valid as of software version:  
FW: V 01.00.00  
HW: V 01.00

## Table of contents

<b>1</b>	<b>Safety instructions</b> .....	<b>3</b>	9.4	Spare Parts .....	37
1.1	Designated use .....	3	9.5	Return .....	37
1.2	Installation, commissioning and operation .....	3	9.6	Disposal .....	38
1.3	Operational safety .....	3	9.7	Software history .....	38
1.4	Notes on safety conventions and icons .....	4	9.8	Contact addresses at Endress+Hauser .....	38
<b>2</b>	<b>Identification</b> .....	<b>5</b>	<b>10</b>	<b>Technical data</b> .....	<b>38</b>
2.1	Device designation .....	5	10.1	Technical data: probe .....	38
2.2	Scope of delivery .....	12	10.2	Input .....	39
2.3	Certificates and approvals .....	12	10.3	Output .....	39
2.4	Trademarks .....	12	10.4	Performance characteristics .....	39
<b>3</b>	<b>Installation</b> .....	<b>13</b>	10.5	Power supply .....	41
3.1	Quick installation guide .....	13	10.6	Operating conditions: Environment .....	42
3.2	Incoming acceptance, transport, storage .....	13	10.7	Operating conditions: Process .....	44
3.3	Planning instructions .....	14	10.8	Certificates and approvals .....	46
3.4	Measuring condition .....	15	10.9	Documentation .....	47
3.5	Minimum probe length for nonconductive media ( $<1\mu\text{s}/\text{cm}$ ) .....	16	<b>Index</b> .....	<b>49</b>	
3.6	Installation examples .....	16			
3.7	With separate housing .....	21			
3.8	Installation instructions .....	24			
3.9	Post-installation check .....	26			
<b>4</b>	<b>Wiring</b> .....	<b>27</b>			
4.1	Recommendations for connection .....	27			
4.2	Wiring and connecting .....	28			
4.3	Post-connection check .....	31			
<b>5</b>	<b>Operation</b> .....	<b>32</b>			
5.1	Operating options .....	32			
5.2	Display and operating elements .....	32			
5.3	Error messages .....	32			
<b>6</b>	<b>Commissioning</b> .....	<b>33</b>			
6.1	Function check .....	33			
6.2	Transmitter .....	33			
<b>7</b>	<b>Maintenance</b> .....	<b>34</b>			
<b>8</b>	<b>Accessories</b> .....	<b>35</b>			
8.1	Protective cover .....	35			
8.2	Shortening set for FMI52 .....	35			
8.3	Commubox FXA195 HART .....	35			
8.4	HAW56x surge arrester .....	35			
8.5	Weld-in adapter .....	35			
<b>9</b>	<b>Troubleshooting</b> .....	<b>35</b>			
9.1	Error analysis .....	35			
9.2	Application errors .....	36			
9.3	Possible measuring errors .....	36			

# 1 Safety instructions

## 1.1 Designated use

Liquicap M FMI51, FMI52 are compact, capacitance level transmitters for the continuous measurement of liquids.

## 1.2 Installation, commissioning and operation

Liquicap M is designed to meet state-of-the-art safety regulations and complies with the applicable requirements and EC Directives. If used improperly or other than intended, the device can, however, be a source of application-related danger, e.g. product overflow as a result of incorrect installation or configuration. For this reason, installation, electrical connection, commissioning, operation and maintenance of the measuring system must only be carried out by trained technical personnel authorized to perform such work by the owner-operator. The technical personnel must have read and understood these Operating Instructions and must follow the instructions they contain. The device may only be repaired or modified if expressly permitted in the Operating Instructions.

## 1.3 Operational safety

When performing configuration, testing and maintenance work on the device, alternative supervisory measures must be taken to guarantee the operational safety and process safety.













### 1.3.1 Ex area

When using the measuring system in Ex-areas, the appropriate national standards and regulations have to be observed. Separate Ex documentation, which constitutes an integral part of this documentation, is supplied with the device. The installation procedures, connection data and safety instructions it contains must be observed.

- Make sure that the technical staff has adequate training.
- The special measuring and safety-related requirements for the measuring points must be observed.

## 1.4 Notes on safety conventions and icons

To highlight safety-related or alternative processes, we have designed the following safety instructions where every instruction is indicated by a corresponding pictogram.

Safety instructions	
	<p><b>Warning!</b> Draws attention to activities or procedures that can result in serious injuries to persons, a safety risk or the destruction of the device if not carried out properly.</p>
	<p><b>Caution!</b> Draws attention to activities or procedures that can result in injuries to persons or the defective operation of the device if not carried out properly.</p>
	<p><b>Note!</b> Draws attention to activities or procedures that have an indirect effect on operation, or can trigger an unforeseen device reaction if not carried out properly.</p>
Type of protection	
	<p><b>Explosion-protected equipment tested for type examination</b> If this sign can be found on the nameplate of the device, the device can be operated in hazardous areas or non-hazardous areas in accordance with the approval</p>
	<p><b>Ex area</b> This symbol in the drawings in these Operating Instructions indicates Ex-areas. Devices located in Ex-areas, or cables for such devices, must have appropriate explosion protection.</p>
	<p><b>Safe area (non-hazardous area)</b> This symbol in the drawings in these Operating Instructions indicates non-Ex areas. Devices in non-hazardous areas must also be certified if connecting cables lead into hazardous areas.</p>
Electrical symbols	
	<p><b>Direct current</b> A terminal to which direct voltage is applied or through which the direct current flows.</p>
	<p><b>Alternating current</b> A terminal to which alternating voltage (sine wave) is applied or through which the alternating current flows.</p>
	<p><b>Ground connection</b> A grounded terminal which, from a user's point of view, is grounded via a grounding system.</p>
	<p><b>Protective earth connection</b> A terminal that has to be grounded before any other connections may be established.</p>
	<p><b>Equipotential connection</b> A connection that has to be connected to the grounding system of the plant. This can be a potential matching line or a star grounding system, depending on national or company codes of practice.</p>
	<p><b>Immunity to temperature change of the connecting cables</b> Means that the connecting cables have to withstand a temperature of 85 °C at least.</p>

## 2 Identification

### 2.1 Device designation

#### 2.1.1 Nameplate

You can take the following technical data from the nameplate of the device:

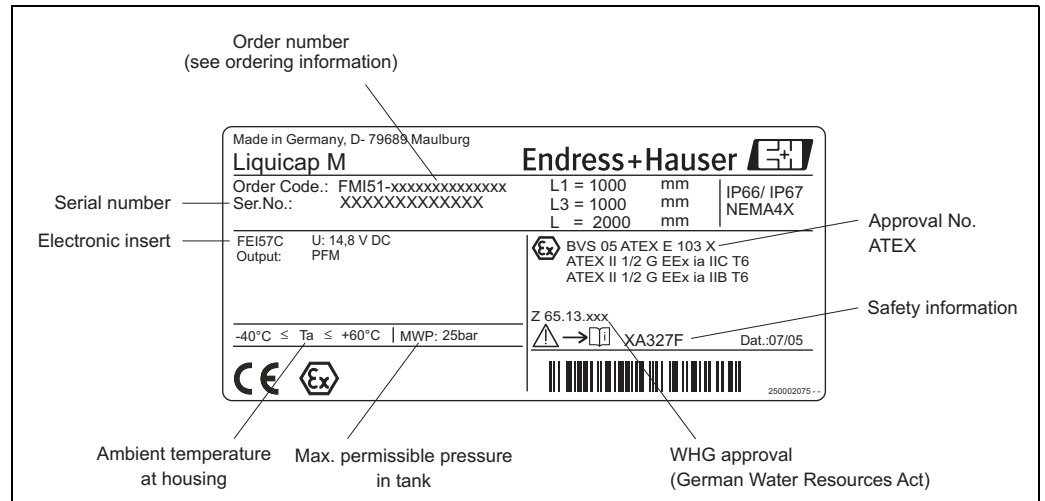

Information on the Liquicap M nameplate (example)

#### 2.1.2 Product structure



Note!

The product structure is used to identify the alphanumeric order number (see nameplate: Order Code).

#### Liquicap M FMI51 (device identification)

10	Approval:
A	Non-hazardous area
B	Non-hazardous area, WHG
C	ATEX II 1/2 GD Ex ia IIC T6
D	ATEX II 1/2 GD Ex ia IIC T6, WHG
E	ATEX II 1/2 GD Ex ia IIB T6
F	ATEX II 1/2 GD Ex ia IIB T6, WHG
G	ATEX II 1/2 G Ex d (ia) IIB T6, WHG
H	ATEX II 1/2 GD Ex ia IIC T6, XA, note safety instruction (XA) (electrostatic charging)!
J	ATEX II 1/2 GD Ex ia IIC T6, WHG XA, note safety instruction (XA) (electrostatic charging)!
K	ATEX II 1/2 G Ex ia IIC T6, WHG XA, note safety instruction (XA) (electrostatic charging)!
L	ATEX II 1/2 G Ex de (ia) IIC T6, WHG XA, note safety instruction (XA) (electrostatic charging)!
M	ATEX II 3 GD Ex nA II T6, WHG XA, note safety instruction (XA) (electrostatic charging)!
N	CSA General Purpose, CSA C US
P	CSA/FM IS Cl. I, II, III Div. 1+2 Gr. A-G
R	CSA/FM XP Cl. I, II, III Div. 1+2 Gr. A-G
S	TIIS Ex ia IIC T3
T	TIIS Ex d IIC T3
1	NEPSI Ex ia IIC T6
2	NEPSI Ex d(ia) IIC T6
4	NEPSI Ex nA IIC T6
5	IECEx Ga/Gb Ex ia IIC T6; Ex iaD 20/ Ex tD A21

<b>10</b>	<b>Approval:</b>			
	6	IECEX Ga/Gb Ex ia IIC T6		
	Y	Special version, to be specified		
<b>20</b>	<b>Inactive Length L3:</b>			
		Price per 100 mm/1 inch		
		L3: 100 to 2000 mm/4 to 80 inch for 316L		
		L3: 150 to 1000 mm/6 to 40 inch for PTFE fully insulated		
		Protection against condensate + bypassing container nozzles		
	1	Not selected		
	2	... mm,	316L	
	3	... mm,	316L + fully insulated PTFE	
	5	... inch,	316L	
	6	... inch,	316L + fully insulated PTFE	
	9	Special version, to be specified		
<b>30</b>	<b>Active Probe Length L1; Insulation:</b>			
		Price per 100 mm/1 inch		
		L1: 100 to 4000 mm/4 to 160 inch for Ø10 mm, Ø16 mm		
		L1: 150 to 3000 mm/6 to 120 inch for Ø22 mm (fully insulated)		
	A	... mm L1, 10 mm rod,	316L; PTFE	
	B	... mm L1, 16 mm rod,	316L; PTFE	
	C	... mm L1, 22 mm rod,	316L; PTFE	
	D	... mm L1, 16 mm rod,	316L; PFA	
	E	... mm L1, 10 mm rod,	316L; PTFE + ground tube	
	F	... mm L1, 16 mm rod,	316L; PTFE + ground tube	
	G	... mm L1, 16 mm rod,	316L; PFA + ground tube	
	H	... inch L1, 0.4 inch rod,	316L; PTFE	
	K	... inch L1, 0.6 inch rod,	316L; PTFE	
	M	... inch L1, 0.9 inch rod,	316L; PTFE	
	N	... inch L1, 0.6 inch rod,	316L; PFA	
	P	... inch L1, 0.4 inch rod,	316L; PTFE + ground tube	
	R	... inch L1, 0.6 inch rod,	316L; PTFE + ground tube	
	S	... inch L1, 0.6 inch rod,	316L; PFA + ground tube	
	Y	Special version, to be specified		
<b>50</b>	<b>Process Connection:</b>			Ø inactive length (mm)
	<b>Threaded connection</b>			
	GCJ	G ½,	316L, 25 bar	Thread ISO228 22
	GDJ	G ¾,	316L, 25 bar	Thread ISO228 22
	GEJ	G 1,	316L, 25 bar	Thread ISO228 22
	GGJ	G 1½,	316L, 100 bar	Thread ISO228 43
	RCJ	NPT ½,	316L, 25 bar	Thread ANSI 22
	RDJ	NPT ¾,	316L, 25 bar	Thread ANSI 22
	REJ	NPT 1,	316L, 25 bar	Thread ANSI 22
	RGJ	NPT 1½,	316L, 100 bar	Thread ANSI 43
	<b>Hygiene connection</b>			
	GOJ	G ¾	316L, 25 bar, EHEDG	Thread ISO228 -
		Accessories installation, weld-in adapter		
	GWJ	G 1	316L, 25 bar, EHEDG	Thread ISO228 -
		Accessories installation, weld-in adapter		
	MRJ	DN50 PN40,	316L	DIN11851 22/43***
	UPJ	Universal adapter 44 mm	316L, 16 bar	-
	<b>Tri-Clamp connection</b>			
	TCJ	DN25 (1"), EHEDG	316L,	Tri-Clamp ISO2852 22
	TJJ	DN38 (1½"), EHEDG	316L,	Tri-Clamp ISO2852 22
	TJK	DN38 (1½"), EHEDG	PTFE >316L, 3A	Tri-Clamp ISO2852 22
	TDJ	DN40-51 (2"),	316L,	Tri-Clamp ISO2852 43
	TDK	DN40-51 (2"), EHEDG	PTFE >316L, 3A,	Tri-Clamp ISO2852 -
	TNJ	DN38 (1½"),	316L, 3A, EHEDG	Tri-Clamp ISO2852 -
		clamp detachable		
	<b>EN flanges</b>			
	B0J	DN25 PN25/40 A,	316L	Flange EN1092-1 (DIN2527 B) 22
	B1J	DN32 PN25/40 A,	316L	Flange EN1092-1 (DIN2527 B) 22
	B2J	DN40 PN25/40 A,	316L	Flange EN1092-1 (DIN2527 B) 22

50	Process Connection:					∅ inactive length (mm)	
	B3J	DN50 PN25/40 A,	316L		Flange EN1092-1 (DIN2527 B)	22/43***	
	CRJ	DN50 PN25/40 B1,	316L		Flange EN1092-1 (DIN2527 C)	43	
	DRJ	DN50 PN40 C,	316L		Flange EN1092-1 (DIN2512 F)	43	
	ERJ	DN50 PN40 D,	316L		Flange EN1092-1 (DIN2512 N)	43	
	BSJ	DN80 PN10/16 A,	316L		Flange EN1092-1 (DIN2527 B)	43	
	CGJ	DN80 PN10/16 B1,	316L		Flange EN1092-1 (DIN2527 C)	43	
	DGJ	DN80 PN16 C,	316L		Flange EN1092-1 (DIN2512 F)	43	
	EGJ	DN80 PN16 D,	316L		Flange EN1092-1 (DIN2512 N)	43	
	BTJ	DN100 PN10/16 A,	316L		Flange EN1092-1 (DIN2527 B)	43	
	CHJ	DN100 PN10/16 B1,	316L		Flange EN1092-1 (DIN2527 C)	43	
		PTFE clad					
	B0K	DN25 PN25/40,	PTFE >316L		Flange EN1092-1 (DIN2527)	-	
	B1K	DN32 PN25/40,	PTFE >316L		Flange EN1092-1 (DIN2527)	-	
	B2K	DN40 PN25/40,	PTFE >316L		Flange EN1092-1 (DIN2527)	-	
	B3K	DN50 PN25/40,	PTFE >316L		Flange EN1092-1 (DIN2527)	-	
	BSK	DN80 PN10/16,	PTFE >316L		Flange EN1092-1 (DIN2527)	-	
	BTK	DN100 PN10/16,	PTFE >316L		Flange EN1092-1 (DIN2527)	-	
	<b>ANSI flanges</b>						
	ACJ	1" 150 lbs RF,	316/316L		Flange ANSI B16.5	22	
	ANJ	1" 300 lbs RF,	316/316L		Flange ANSI B16.5	22	
	AEJ	1½" 150 lbs RF,	316/316L		Flange ANSI B16.5	22	
	AQJ	1½" 300 lbs RF,	316/316L		Flange ANSI B16.5	22	
	AFJ	2" 150 lbs RF,	316/316L		Flange ANSI B16.5	22/43***	
	ARJ	2" 300 lbs RF,	316/316L		Flange ANSI B16.5	22/43***	
	AGJ	3" 150 lbs RF,	316/316L		Flange ANSI B16.5	43	
	ASJ	3" 300 lbs RF,	316/316L		Flange ANSI B16.5	43	
	AHJ	4" 150 lbs RF,	316/316L		Flange ANSI B16.5	43	
	ATJ	4" 300 lbs RF,	316/316L		Flange ANSI B16.5	43	
	AJJ	6" 150 lbs RF,	316/316L		Flange ANSI B16.5	43	
	AUJ	6" 300 lbs RF,	316/316L		Flange ANSI B16.5	43	
		PTFE clad					
	ACK	1" 150 lbs,	PTFE >316/316L		Flange ANSI B16.5	-	
	ANK	1" 300 lbs,	PTFE >316/316L		Flange ANSI B16.5	-	
	AEK	1½" 150 lbs,	PTFE >316/316L		Flange ANSI B16.5	-	
	AQK	1½" 300 lbs,	PTFE >316/316L		Flange ANSI B16.5	-	
	AFK	2" 150 lbs,	PTFE >316/316L		Flange ANSI B16.5	-	
	ARK	2" 300 lbs,	PTFE >316/316L		Flange ANSI B16.5	-	
	AGK	3" 150 lbs,	PTFE >316/316L		Flange ANSI B16.5	-	
	AHK	4" 150 lbs,	PTFE >316/316L		Flange ANSI B16.5	-	
	<b>JIS flanges</b>						
	KCJ	10K 25 RF,	316L		Flange JIS B2220	22	
	KEJ	10K 40 RF,	316L		Flange JIS B2220	22	
	KFJ	10K 50 RF,	316L		Flange JIS B2220	22/43***	
	KGJ	10K 80 RF,	316L		Flange JIS B2220	22/43***	
	KHJ	10K 100 RF,	316L		Flange JIS B2220	22/43***	
	KRJ	20K 50 RF,	316L		Flange JIS B2220	43	
		PTFE clad					
	KCK	10K 25 RF,	PTFE >316L		Flange JIS B2220	-	
	KEK	10K 40 RF,	PTFE >316L		Flange JIS B2220	-	
	KFK	10K 50 RF,	PTFE >316L		Flange JIS B2220	-	
	KGK	10K 80 RF,	PTFE >316L		Flange JIS B2220	-	
	KHK	10K 100 RF,	PTFE >316L		Flange JIS B2220	-	
	YY9	Special version, to be specified					

<b>60</b>											<b>Electronics; Output:</b>
											A FEI50H; 4 to 20 mA HART + display B FEI50H; 4 to 20 mA HART C FEI57C; PFM V None; Prepared for FEI5x + display, cover high, transparent W None; Prepared for FEI5x, cover flat Y Special version, to be specified
<b>70</b>											<b>Housing:</b>
											1 F15 316L IP66, NEMA4X 2 F16 polyester IP66, NEMA4X 3 F17 aluminum IP66, NEMA4X 4 F13 aluminum IP66, NEMA4X + gas-tight probe seal 5 T13 Alu IP66, NEMA4X + gas-tight probe seal + separate connection compartment 6 F27 316L IP68, NEMA6P + gas-tight probe seal 9 Special version, to be specified
<b>80</b>											<b>Cable Entry:</b>
											A Gland M20 (Ex d > thread M20) B Thread G ½ C Thread NPT ½ D Thread NPT ¾ E Plug M12 Y Special version, to be specified
<b>90</b>											<b>Type of Probe:</b>
											L4: 300 to 6000 mm/12 to 240 inch 1 Compact 2 2000 mm L4 cable > separate housing 3 ....mm L4 cable > separate housing 4 80 inch L4 cable > separate housing 5 ....inch L4 cable > separate housing 9 Special version, to be specified
<b>100</b>											<b>Additional Option:</b>
											A Basic version B PWIS free, PWIS = paint-wetting impairment substances C Metal probe rod surface refining** D EN10204-3.1, (316L wetted parts/pressurized), inspection certificate E EN10204-3.1, NACE MR0175 (316L wetted parts/pressurized), inspection certificate F SIL Declaration of Conformity S GL marine certificate Y Special version, to be specified
<b>FMI51</b>											Product designation
* With this option, the complete device is cleaned for applications free from paint-wetting impairment substances. ** With this option, the surface of the probe rod (316L) is passivated and acts as additional corrosion protection *** Depends on the probe rod Ø (10 mm -> 22 mm; 16 mm -> 43 mm; 22 mm rod not with inactive length)											



## Liquicap M FMI51 (device identification)

10	Approval:			
	A	Non-hazardous area		
	B	Non-hazardous area,	WHG	
	E	ATEX II 1/2 GD	Ex ia IIB T6	
	F	ATEX II 1/2 GD	Ex ia IIB T6,	WHG
	G	ATEX II 1/2 G	Ex d (ia) IIB T6,	WHG
	H	ATEX II 1/2 GD	Ex ia IIC T6,	
		XA, note safety instruction (XA) (electrostatic charging)!		
	J	ATEX II 1/2 GD	Ex ia IIC T6,	
		XA, note safety instruction (XA) (electrostatic charging)!		
	K	ATEX II 1/2 G	Ex ia IIC T6,	WHG
		XA, note safety instruction (XA) (electrostatic charging)!		
	L	ATEX II 1/2 G	Ex de (ia) IIC T6,	WHG
		XA, note safety instruction (XA) (electrostatic charging)!		
	M	ATEX II 3 GD	Ex nA II T6,	WHG
		XA, note safety instruction (XA) (electrostatic charging)!		
	N	CSA General Purpose, CSA C US		
	P	CSA/FM IS Cl. I, II, III	Div. 1+2 Gr. A-G	
	R	CSA/FM XP Cl. I, II, III	Div. 1+2 Gr. A-G	
	S	TIIS Ex ia IIC T3		
	T	TIIS Ex d IIC T3		
	1	NEPSI Ex ia IIC T6		
	2	NEPSI Ex d(ia) IIC T6		
	4	NEPSI Ex nA IIC T6		
	5	IECEX Ga/Gb Ex ia IIC T6; Ex iaD 20/ Ex tD A21		
	6	IECEX Ga/Gb Ex ia IIC T6		
	Y	Special version, to be specified		
20	Inactive Length L3:			
		Price per 100 mm/1 inch		
		L3: 100 to 2000 mm/4 to 80 inch for 316L		
		L3: 150 to 1000 mm/6 to 40 inch for PFA fully insulated		
		Protection against condensate + bypassing container nozzles		
	1	Not selected		
	2	... mm L3,	316L	
	3	... mm L3,	316L + fully insulated PFA	
	5	... inch L3,	316L	
	6	... inch L3,	316L + fully insulated PFA	
	9	Special version, to be specified		
30	Active Probe Length L1; Insulation:			
		Price per 1000 mm/10 inch		
		L1: 420 to 10000 mm/17 to 400 inch; fully insulated		
	A	... mm L1,	316; FEP	
	B	... mm L1,	316; PFA	
	C	... inch L1,	316; FEP	
	D	... inch L1,	316; PFA	
	Y	Special version, to be specified		
50	Process Connection: <span style="float: right;">∅ inactive length (mm)</span>			
		<b>Threaded connection</b>		
	GDJ	G ¾,	316L, 25 bar	Thread ISO228 22
	GEJ	G 1,	316L, 25 bar	Thread ISO228 22
	GGJ	G 1½,	316L, 100 bar	Thread ISO228 43
	RDJ	NPT ¾,	316L, 25 bar	Thread ANSI 22
	REJ	NPT 1,	316L, 25 bar	Thread ANSI 22
	RGJ	NPT 1½,	316L, 100 bar	Thread ANSI 43
		<b>Hygiene connection</b>		
	GWJ	G 1	316L, 25 bar, EHEDG	Thread ISO228 -
		Accessories installation, weld-in adapter		
	MRJ	DN50 PN40,	316L	DIN11851 43
	UPJ	Universal adapter 44 mm	316L, 16 bar, EHEDG	-
		<b>Tri-Clamp connection</b>		
	TCJ	DN25 (1"), EHEDG	316L,	Tri-Clamp ISO2852 22
	TJJ	DN38 (1½"), EHEDG	316L,	Tri-Clamp ISO2852 22
	TJK	DN38 (1½"), EHEDG	PTFE >316L, 3A	Tri-Clamp ISO2852 22
	TDJ	DN40-51 (2"),	316L,	Tri-Clamp ISO2852 43

50	Process Connection:				∅ inactive length (mm)
	TDK	DN40-51 (2"), EHEDG	PTFE >316L, 3A,	Tri-Clamp ISO2852	-
	<b>EN flanges</b>				
	B0J	DN25 PN25/40 A,	316L	Flange EN1092-1 (DIN2527 B)	22
	B1J	DN32 PN25/40 A,	316L	Flange EN1092-1 (DIN2527 B)	22
	B2J	DN40 PN25/40 A,	316L	Flange EN1092-1 (DIN2527 B)	22
	B3J	DN50 PN25/40 A,	316L	Flange EN1092-1 (DIN2527 B)	43
	CRJ	DN50 PN25/40 B1,	316L	Flange EN1092-1 (DIN2527 C)	43
	DRJ	DN50 PN40 C,	316L	Flange EN1092-1 (DIN2512 F)	43
	ERJ	DN50 PN40 D,	316L	Flange EN1092-1 (DIN2512 N)	43
	BSJ	DN80 PN10/16 A,	316L	Flange EN1092-1 (DIN2527 B)	43
	CGJ	DN80 PN10/16 B1,	316L	Flange EN1092-1 (DIN2527 C)	43
	DGJ	DN80 PN16 C,	316L	Flange EN1092-1 (DIN2512 F)	43
	EGJ	DN80 PN16 D,	316L	Flange EN1092-1 (DIN2512 N)	43
	BTJ	DN100 PN10/16 A,	316L	Flange EN1092-1 (DIN2527 B)	43
	CHJ	DN100 PN10/16 B1,	316L	Flange EN1092-1 (DIN2527 C)	43
	PTFE clad				
	B0K	DN25 PN25/40,	PTFE >316L	Flange EN1092-1 (DIN2527)	-
	B1K	DN32 PN25/40,	PTFE >316L	Flange EN1092-1 (DIN2527)	-
	B2K	DN40 PN25/40,	PTFE >316L	Flange EN1092-1 (DIN2527)	-
	B3K	DN50 PN25/40,	PTFE >316L	Flange EN1092-1 (DIN2527)	-
	BSK	DN80 PN10/16,	PTFE >316L	Flange EN1092-1 (DIN2527)	-
	BTK	DN100 PN10/16,	PTFE >316L	Flange EN1092-1 (DIN2527)	-
	<b>ANSI flanges</b>				
	ACJ	1" 150 lbs RF,	316/316L	Flange ANSI B16.5	22
	ANJ	1" 300 lbs RF,	316/316L	Flange ANSI B16.5	22
	AEJ	1½" 150 lbs RF,	316/316L	Flange ANSI B16.5	22
	AQJ	1½" 300 lbs RF,	316/316L	Flange ANSI B16.5	43
	AFJ	2" 150 lbs RF,	316/316L	Flange ANSI B16.5	43
	ARJ	2" 300 lbs RF,	316/316L	Flange ANSI B16.5	43
	AGJ	3" 150 lbs RF,	316/316L	Flange ANSI B16.5	43
	ASJ	3" 300 lbs RF,	316/316L	Flange ANSI B16.5	43
	AHJ	4" 150 lbs RF,	316/316L	Flange ANSI B16.5	43
	ATJ	4" 300 lbs RF,	316/316L	Flange ANSI B16.5	43
	AJJ	6" 150 lbs RF,	316/316L	Flange ANSI B16.5	43
	AUJ	6" 300 lbs RF,	316/316L	Flange ANSI B16.5	43
	PTFE clad				
	ACK	1" 150 lbs,	PTFE >316/316L	Flange ANSI B16.5	-
	ANK	1" 300 lbs,	PTFE >316/316L	Flange ANSI B16.5	-
	AEK	1½" 150 lbs,	PTFE >316/316L	Flange ANSI B16.5	-
	AQK	1½" 300 lbs,	PTFE >316/316L	Flange ANSI B16.5	-
	AFK	2" 150 lbs,	PTFE >316/316L	Flange ANSI B16.5	-
	ARK	2" 300 lbs,	PTFE >316/316L	Flange ANSI B16.5	-
	AGK	3" 150 lbs,	PTFE >316/316L	Flange ANSI B16.5	-
	AHK	4" 150 lbs,	PTFE >316/316L	Flange ANSI B16.5	-
	<b>JIS flanges</b>				
	KCJ	10K 25 RF,	316L	Flange JIS B2220	22
	KEJ	10K 40 RF,	316L	Flange JIS B2220	22
	KFJ	10K 50 RF,	316L	Flange JIS B2220	43
	KGJ	10K 80 RF,	316L	Flange JIS B2220	43
	KHJ	10K 100 RF,	316L	Flange JIS B2220	43
	KRJ	20K 50 RF,	316L	Flange JIS B2220	43
	PTFE clad				

<b>50</b>	<b>Process Connection:</b>						Ø inactive length (mm)
	KCK	10K	25 RF,	PTFE >316L	Flange JIS B2220	–	
	KEK	10K	40 RF,	PTFE >316L	Flange JIS B2220	–	
	KFK	10K	50 RF,	PTFE >316L	Flange JIS B2220	–	
	KGK	10K	80 RF,	PTFE >316L	Flange JIS B2220	–	
	KHK	10K	100 RF,	PTFE >316L	Flange JIS B2220	–	
	YY9	Special version, to be specified					
<b>60</b>	<b>Electronics; Output:</b>						
	A	FEI50H; 4 to 20 mA HART + display					
	B	FEI50H; 4 to 20 mA HART					
	C	FEI57C; PFM					
	V	None;	Prepared for FEI5x + display,			cover high, transparent	
	W	None;	Prepared for FEI5x,			cover flat	
Y	Special version, to be specified						
<b>70</b>	<b>Housing:</b>						
	1	F15	316L			IP66, NEMA4X	
	2	F16	polyester			IP66, NEMA4X	
	3	F17	aluminum			IP66, NEMA4X	
	4	F13	aluminum + gas-tight probe seal			IP66, NEMA4X	
	5	T13	Alu + gas-tight probe seal + separate connection compartment			IP66, NEMA4X	
	6	F27	316L + gas-tight probe seal			IP68, NEMA6P	
	9	Special version, to be specified					
	<b>80</b>	<b>Cable Entry:</b>					
A		Gland M20 (Ex d > thread M20)					
B		Thread G ½					
C		Thread NPT ½					
D		Thread NPT ¾					
E		Plug M12					
Y	Special version, to be specified						
<b>90</b>	<b>Type of Probe:</b>						
	L4: 100 to 6000 mm/12 to 240 inch						
	1	Compact					
	2	2000 mm	L4 cable	> separate housing			
	3	....mm	L4 cable	> separate housing			
	4	80 inch	L4 cable	> separate housing			
5	....inch	L4 cable	> separate housing				
9	Special version, to be specified						
<b>100</b>	<b>Additional Option:</b>						
	A	Basic version					
	D	EN10204-3.1 (316L wetted parts/pressurized), inspection certificate					
	E	EN10204-3.1, NACE MR0175 (316L wetted parts/pressurized), inspection certificate					
	F	SIL Declaration of Conformity					
	S	GL marine certificate					
Y	Special version, to be specified						
<b>FMI52</b>						Product designation	

## 2.2 Scope of delivery



### Caution!

Please pay attention to the instructions on unpacking, transporting and storing the measuring devices outlined in the "Incoming acceptance, transport, storage" section on → 13.

The scope of delivery comprises:

- The installed device
- Optional accessories (→ 35)

Documentation supplied:

- Operating Instructions
- Approval documentation; if not listed in the Operating Instructions.

## 2.3 Certificates and approvals

### CE mark, Declaration of Conformity

The device has been constructed and tested to state-of-the-art operational safety standards and left the factory in perfect condition as regards technical safety. The device complies with the applicable standards and regulations that are listed in the EC Declaration of Conformity and thus meets the legal requirements of the EC Directives. Endress+Hauser confirms that the device has been tested successfully by affixing the CE mark.

## 2.4 Trademarks

Tri-Clamp®

Registered trademark of Ladish & Co., Inc., Kenosha, USA

## 3 Installation

### 3.1 Quick installation guide

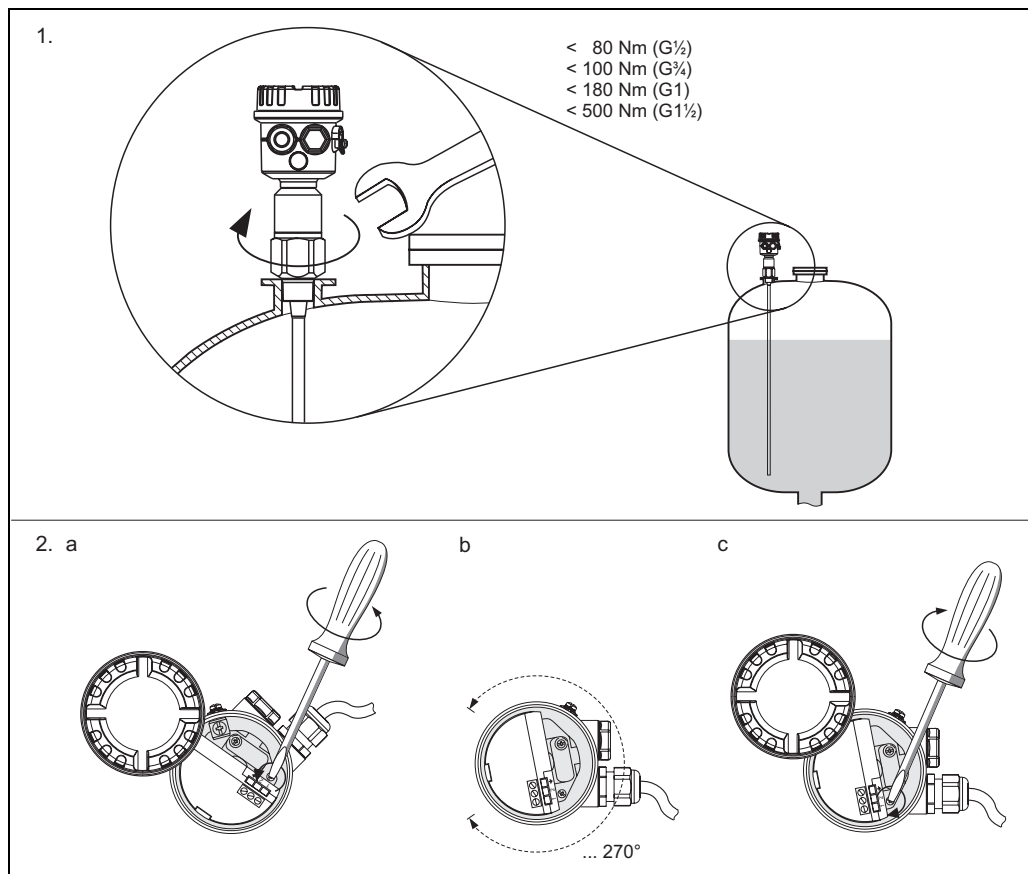

- 1.) Screw in the device
2. a) Loosen clamping screw until the housing rotates easily.
2. b) Align the housing.
2. c) Tighten clamping screw (< 1 Nm) until the housing can no longer be rotated.

## 3.2 Incoming acceptance, transport, storage

### 3.2.1 Incoming acceptance

Check whether the packaging or content is damaged.  
Check that the goods delivered are complete and compare the scope of delivery against the information on your order.

### 3.2.2 Storage

For storage and transportation, pack the device in such a way as to protect it reliably against impact.  
The original packaging offers the best protection for this.  
The permitted storage temperature is  $-50^{\circ}\text{C}$  to  $+85^{\circ}\text{C}$ .

### 3.3 Planning instructions

#### 3.3.1 Installation

The Liquicap M FMI51 (rod probe) can be installed from above and from below.  
The Liquicap M FMI52 (rope probe) can be installed vertically from above.



Note!

- The probe may not come into contact with the container wall!
- Recommended distance from the container floor:  $\geq 10$  mm.
- Do not install probes in the area of the filling curtain!
- If using the probe in agitator tanks, make sure the probe is at a sufficient distance from the agitator.
- Rod probes with a ground tube must be used in the event of severe lateral load.

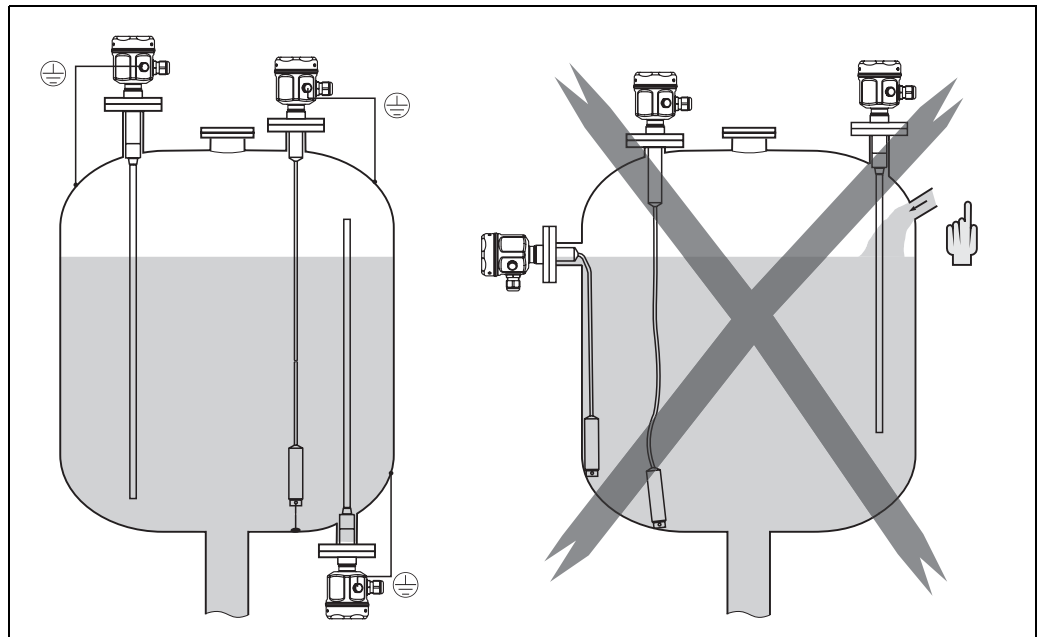

L00-FM15xxxx-11-06-xx-xx-003

### 3.3.2 Support with marine approval (GL)

Conductive or nonconductive support can be provided for fully insulated rod probes. Partially insulated rod probes may only be supported with insulation at the uninsulated end of the probe.



Note!

Rod probes with a diameter of 10 mm and 16 mm have to be supported with a length  $\geq 1$  m (see drawing).

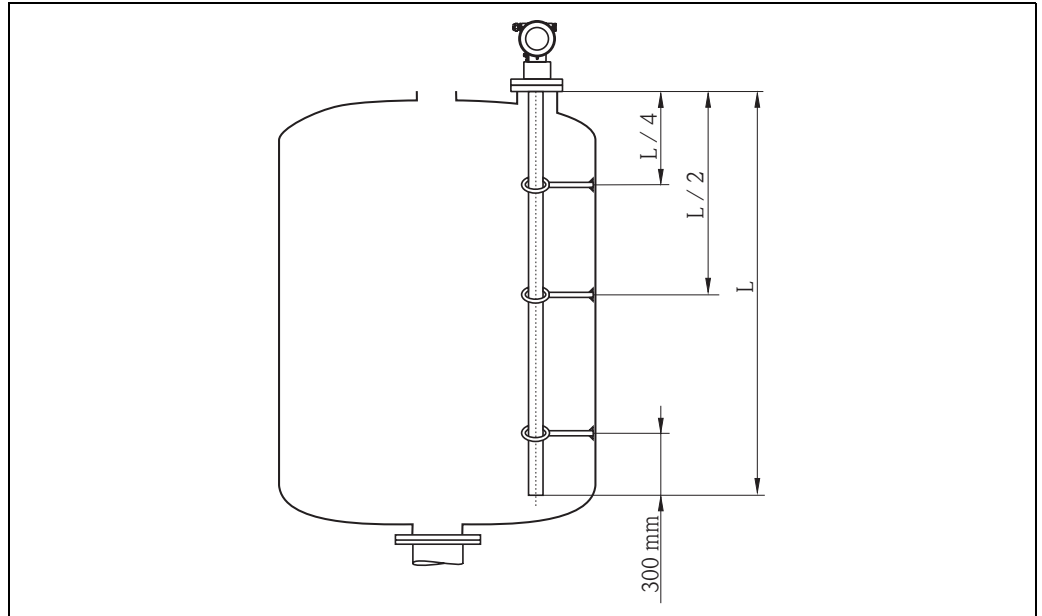

L00-FMI5xxxx-06-05-xx-xx-077

#### Example for calculating distances:

Probe length  $L = 2000$  mm.

$L/4 = 500$  mm

$L/2 = 1000$  mm

Measured from the end of the probe rod = 300 mm.

### 3.4 Measuring condition

- Measuring range  $L1$  possible from the tip of the probe to the process connection.
- Particularly suited for small containers.
- Use a ground tube for nonconductive media.

Note!

When installing in a nozzle, use inactive length ( $L3$ ).

The 0 %, 100 % calibration can be inverted.

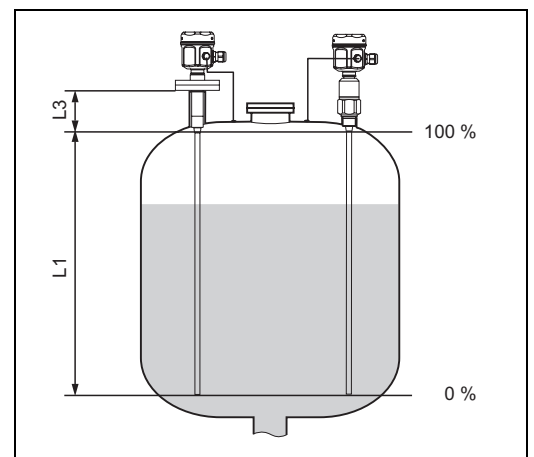

L00-FMI5xxxx-15-05-xx-xx-002

### 3.5 Minimum probe length for nonconductive media (<math><1\mu\text{s}/\text{cm}</math>)

$$l_{\min} = \Delta C_{\min} / (C_s * [\epsilon_r - 1])$$

$l_{\min}$  = Minimum probe length

$\Delta C_{\min}$  = 5 pF

$C_s$  = Probe capacitance in air (see also → 38, "Additional capacitance")

$\epsilon_r$  = Dielectric constant e.g. oil = 2.0

### 3.6 Installation examples

#### 3.6.1 Rod probes

##### Conductive tanks (metal tanks)

If the process connection of the probe is insulated from the metal tank (e.g. using seal material), the ground connection on the probe housing must be connected to the tank using a short line.



Note!

- A fully insulated rod probe may be neither shortened nor extended.
- If the insulation of the probe rod is damaged, this results in an incorrect measurement result.
- These application examples show vertical installation for continuous level measurement.

##### FMI51: rod probe

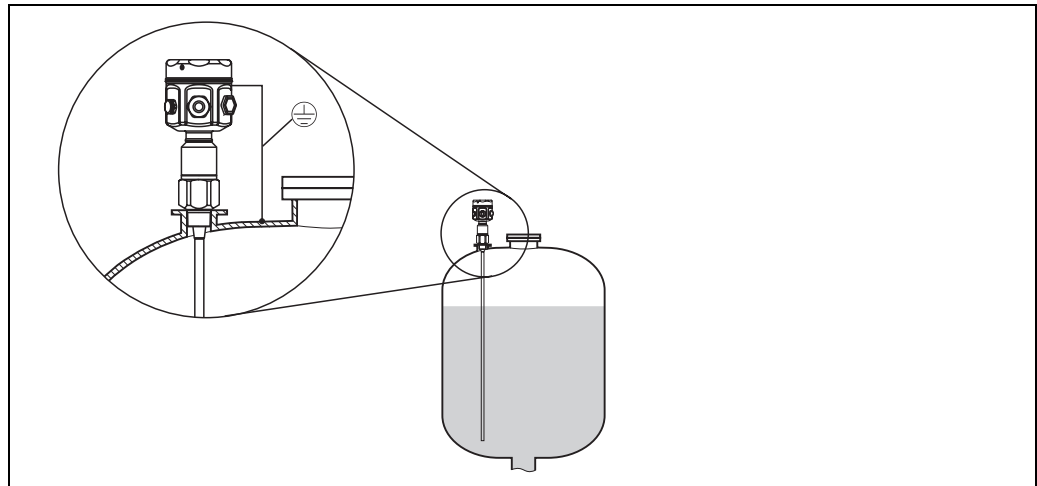

L00-FMI5xxxx-11-06-xx-xx-004



**FMI51: rod probe with ground tube**

*Nonconductive tanks (plastic tanks)*

When installing in a plastic tank, a probe with a ground tube must be used.

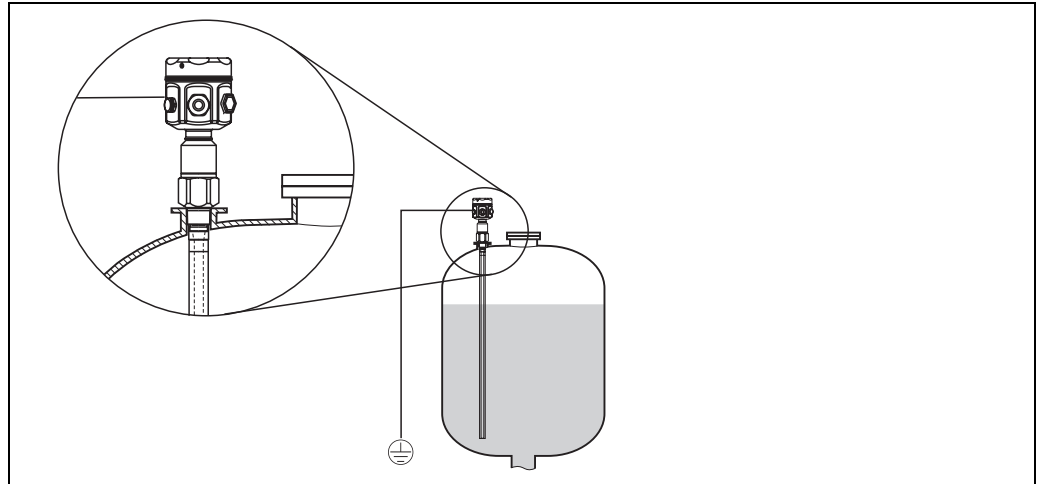

L00-FMI5xxxx-11-00-xx-xx-005

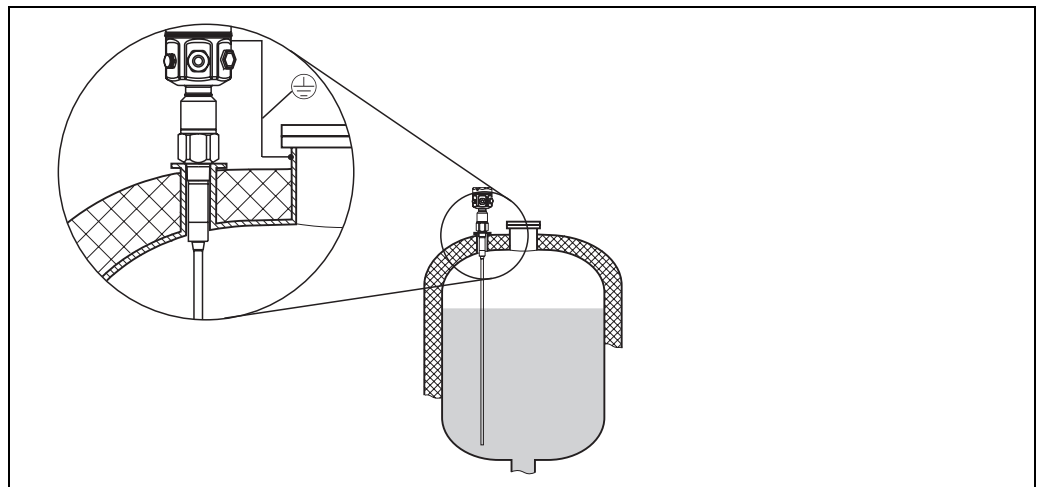
**FMI51: rod probe with inactive length (e.g. for insulated tanks)**

L00-FMI5xxxx-11-00-xx-xx-006

**FMI51: rod probe with ground tube and inactive length (for mounting nozzles)**

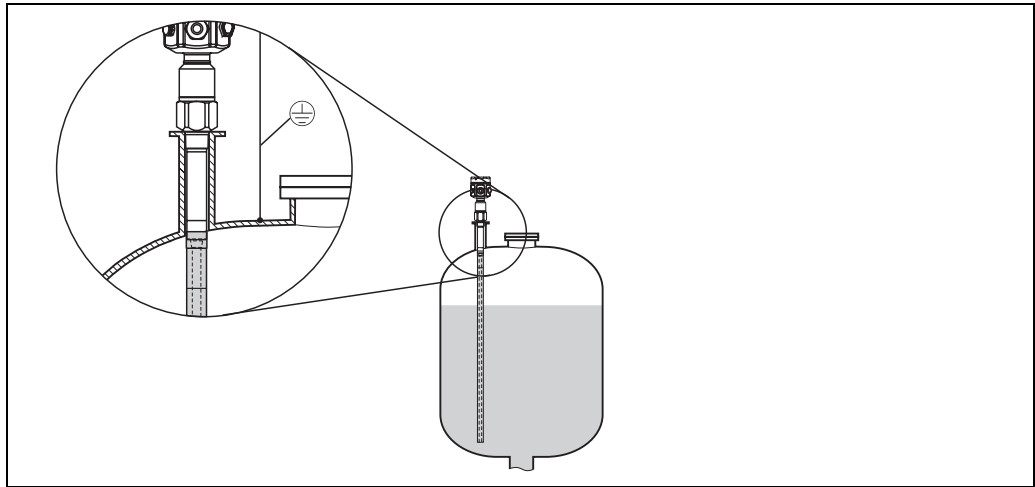

L00-FMI5xxxx-11-06-xx-xx-007

**FMI51: fully insulated probe with clad flange for aggressive media**

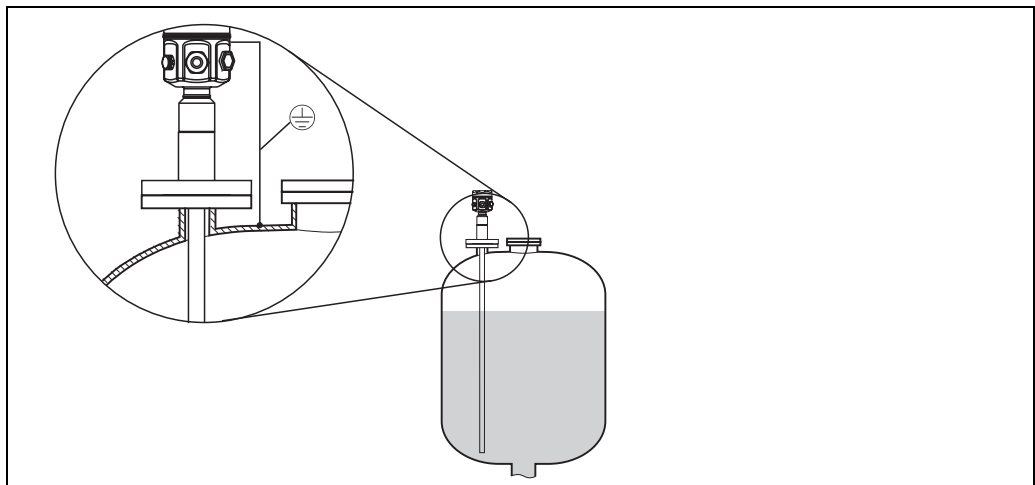

L00-FMI5xxxx-11-06-xx-xx-011

### 3.6.2 Rope probes



Note!

These application examples show the installation of rope probes for continuous level measurement.

#### FMI52: rope probe

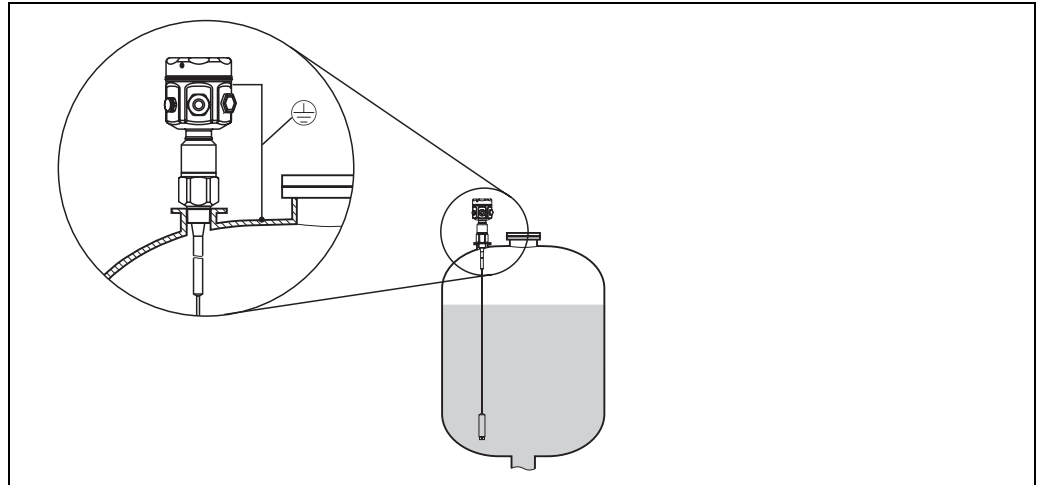

L00-FMI5xxxx-11-06-xx-xx-008

#### FMI52: rope probe with inactive length (e.g. for insulated tanks)

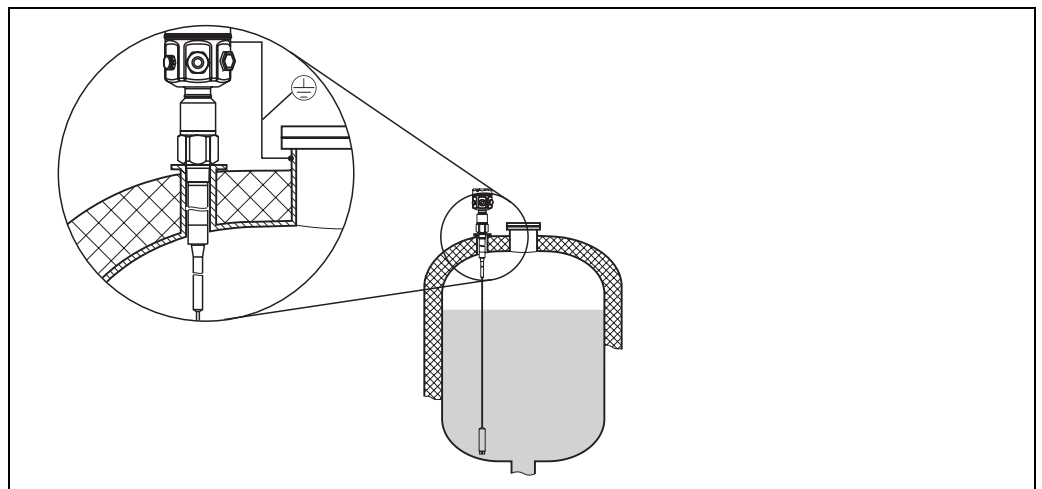

L00-FMI5xxxx-11-06-xx-xx-009

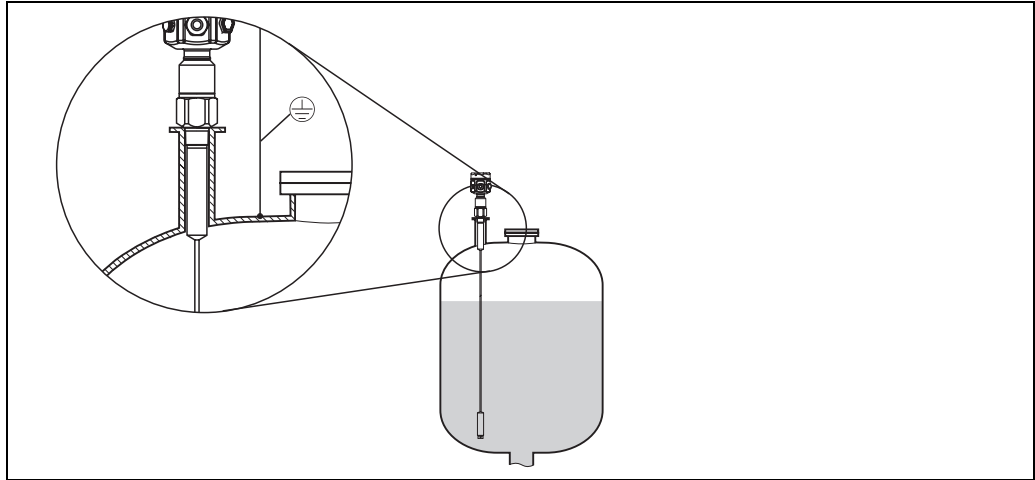
**FMI52: rope probe with fully insulated inactive length (for mounting nozzles)**

L00-FMI5xxxx-11-06-xx-xx-010

**3.6.3 Shortening the rope**

Note!

See Operating Instructions, rope shortening kit KA061F/00.

**3.6.4 Tensioning weight with tension**

The end of the probe needs to be secured if the probe would otherwise touch the silo wall or another part in the tank. This is what the internal thread in the probe weight is intended for.

The bracing can be conductive or insulating to the tank wall.

To avoid too high a tensile load the rope should be loose or guyed with a spring. The maximum tensile load may not exceed 200 Nm.

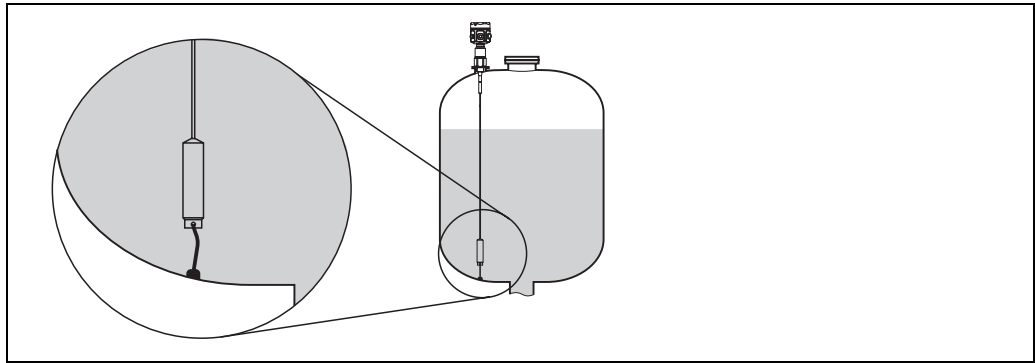

L00-FMI5xxxx-11-06-xx-xx-012

### 3.7 With separate housing

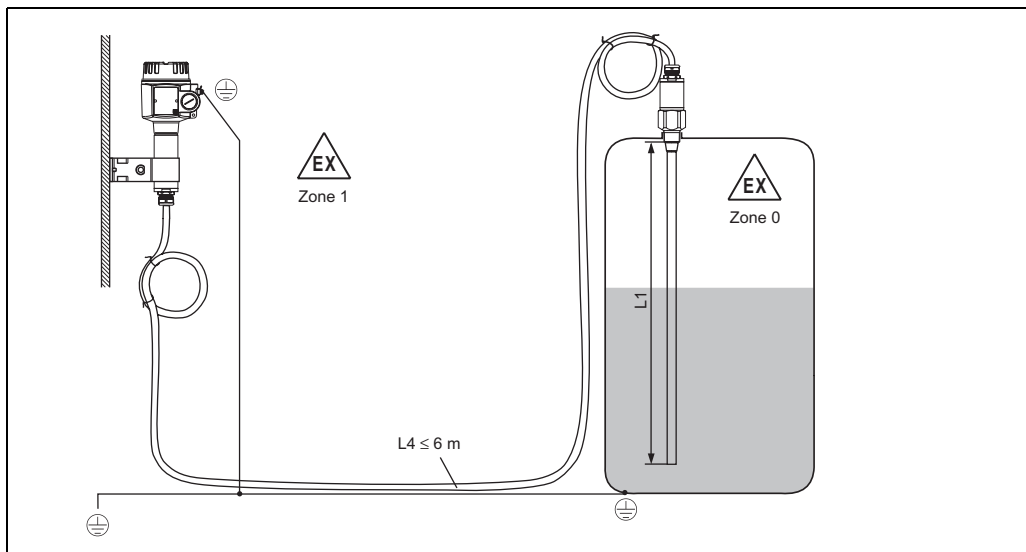

Rod length  $L1$  max. 4 m

Rope length  $L1$  max. 9.7 m (the maximum total length of  $L1 + L4$  should not exceed 10 m).



Note!

- The maximum cable length between probe and separate housing is 6 m ( $L4$ ). The required cable length must be indicated in the ordering process of a Liquicap M with separate housing.
- The total length  $L = L1 + L4$  should not exceed 10 m.
- If the cable connection has to be shortened or led through a wall, it must be separated from the process connection.
- For information on ordering, please refer also to the "Ordering information" => "Probe design" on → 5.

#### 3.7.1 Extension heights: separate housing

Housing side: wall mounting

Housing side: pipe mounting

Sensor side

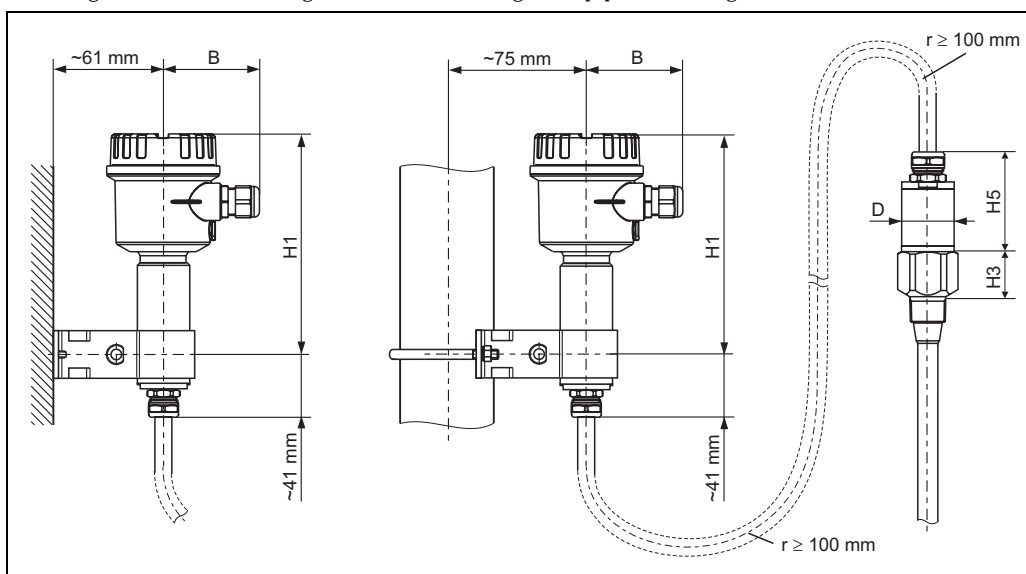

Note!

- The cable has a bending radius of  $r \geq 100$  mm.
- Connecting cable:  $\varnothing 10.5$  mm
- Outer jacket: silicone, notch resistance

	Polyester housing (F16)	Stainless steel housing (F15)	Aluminum housing (F17)
B (mm)	76	64	65
H1 (mm)	172	166	177

		H5 (mm)	D (mm)
Probes Ø10 mm rod		66	38
Probes Ø16 mm rod or rope (without fully insulated inactive length)	G¾", G1", NPT¾", NPT1", Clamp 1", Clamp 1½", Universal Ø44, flange <DN 50, ANSI 2", 10K50	66	38
	G1½", NPT1½", Clamp 2", DIN 11851, flanges ≥DN 50, ANSI 2", 10K50	89	50
Probes Ø 22 mm rod or rope (with fully insulated inactive length)		89	38

### 3.7.2 Wall bracket



Note!

- The wall bracket forms part of the scope of delivery.
- The wall bracket first has to be screwed to the separate housing before you can use it as a drilling template. The distance between the holes is reduced by screwing it to the separate housing.

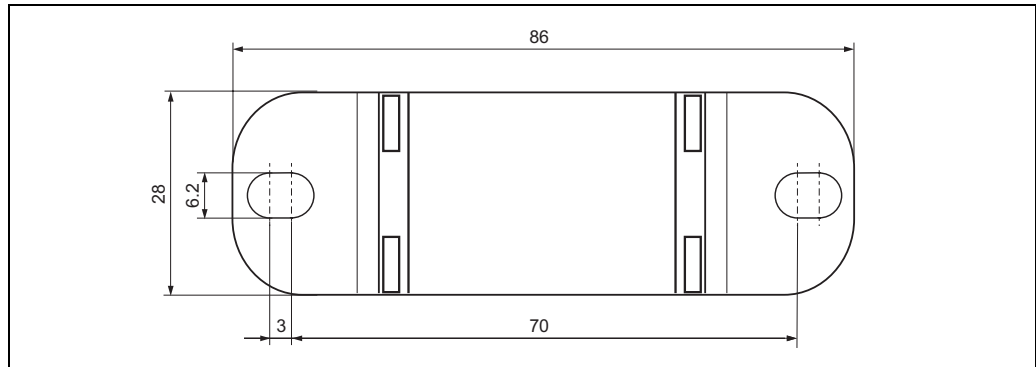

### 3.7.3 Wall mounting

- Push the wall bracket onto the tube and screw it together.
- Mark the distance between the holes on the wall and drill the holes.
- Screw the separate housing on the wall.

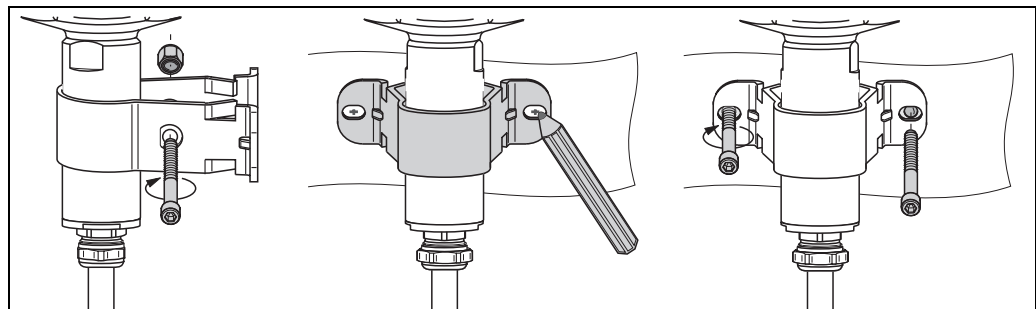

### 3.7.4 Pipe mounting

- Push the wall bracket onto the tube and screw it together.

- Screw the separate housing on a pipe of max. 2”.

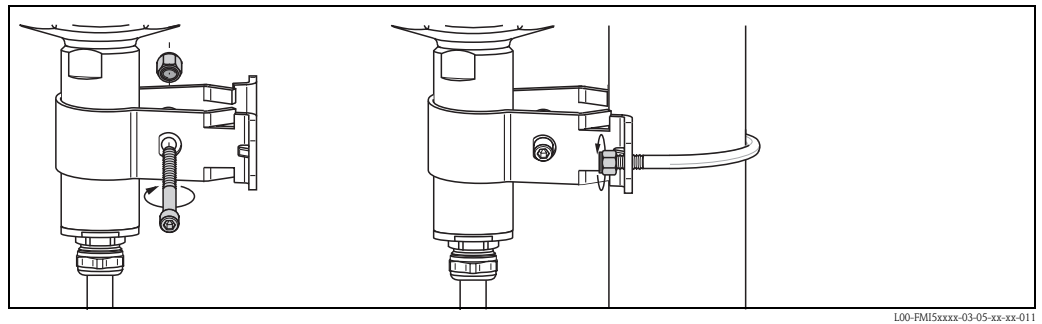

L00-FMI5xxxx-03-05-xx-xx-011

### 3.7.5 Shortening the connecting cable

Recalibration must be performed before commissioning → 33



Note!

The maximum connection length between the probe and the separate housing is 6 m. When ordering a device with a separate housing, the desired length must be specified.

If the cable connection has to be shortened or led through a wall, it must be separated from the process connection. Please proceed as follows:

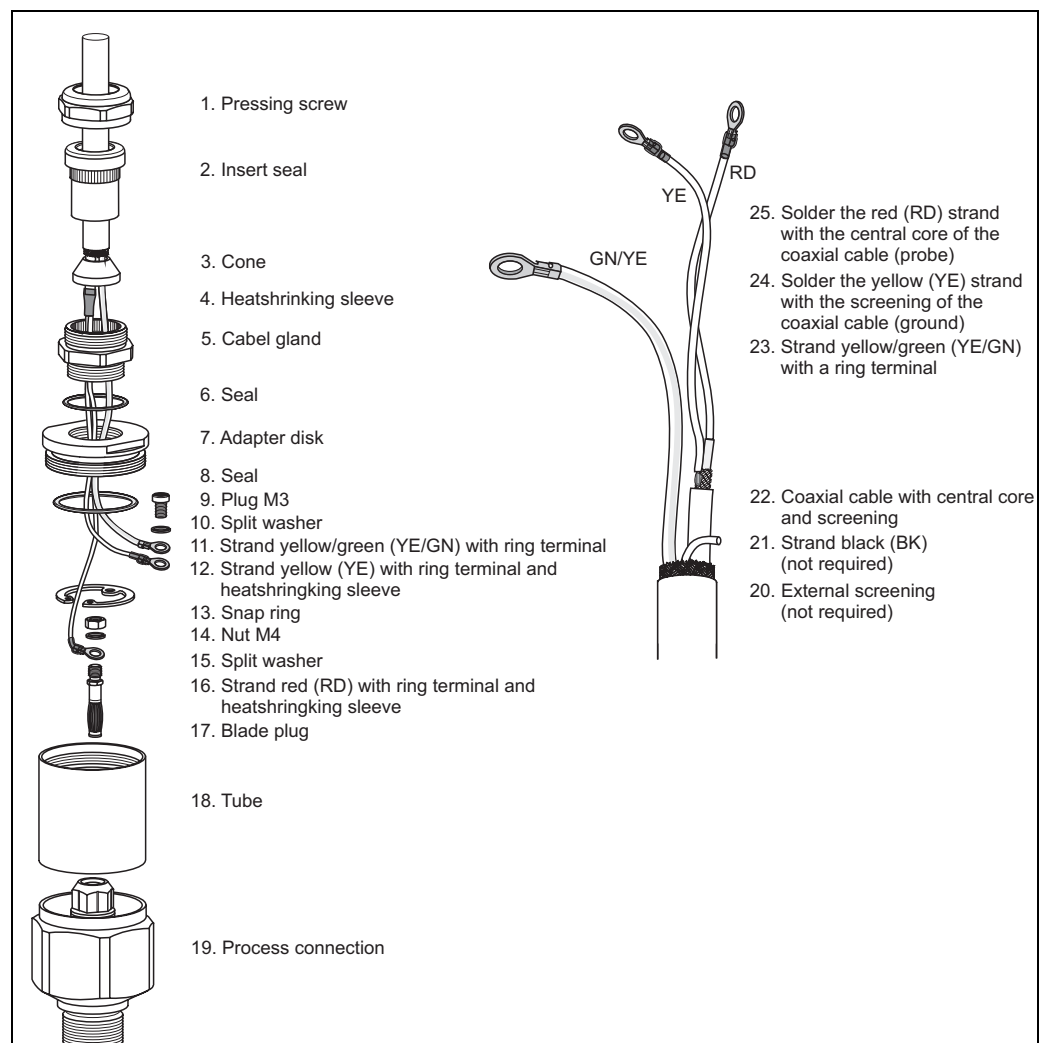

L00-FMI5xxxx-03-05-xx-xx-en-005

- Loosen the pressing screw (1) with an open-end wrench (AF22). If necessary, hold the process connection. Please make sure that neither the connecting cable nor the probe is turning with the pressing screw.
- Pull the insert seal (2) out of the cable gland (5).
- Using an open-end wrench (AF22), disconnect the cable gland (5) from the adapter disk. If necessary, hold it against the adapter disk (7) using an open-end wrench AF34.
- Loosen the adapter disk (7) from the tube (18).
- Remove the snap ring (13) with a pair of snap ring pliers.
- Clutch the nut (M4) of the blade plug with a pair of pliers and pull this out.



Note!

- If you are shortening the connecting cable, we recommend to reuse all strands with ring terminals.
- If the strands are not to be reused, the crimp connections of the new ring terminals fitted must be isolated with a heat shrinking sleeve (risk of short-circuiting).
- All soldered joints must be insulated. Use heat-shrink tubes to do so.

### 3.8 Installation instructions



Caution!

- Do not damage the probe insulation when installing!
- When screwing in the probe, do not turn at the housing as this could damage the housing mounting.

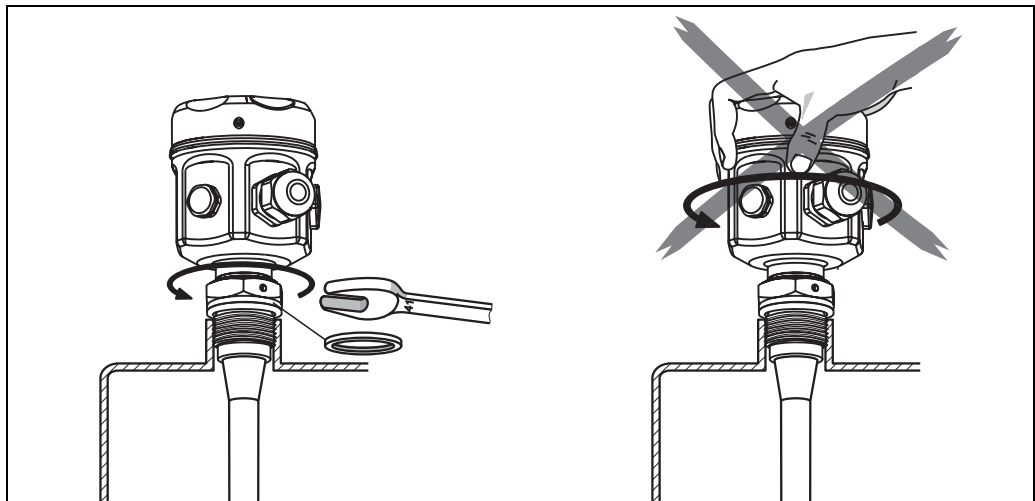

L00-FMI5xxxx-17-00-00-xx-003

#### Probe with thread

G 1/2, G 3/4, G 1 or G 1 1/2 (cylindrical):

To be used with the elastomer fiber seal supplied (pay attention to temperature resistance) or another chemically resistant seal.



Note!

The following applies for probes with a parallel thread and supplied seal:

Thread	For pressures up to 25 bar	For pressures up to 100 bar	Maximum torque
G 1/2	25 Nm	-	80 Nm
G 3/4	30 Nm	-	100 Nm
G 1	50 Nm	-	180 Nm
G 1 1/2	-	300 Nm	500 Nm

1/2 NPT, 3/4 NPT, 1 NPT and 1 1/2 NPT (conical):

Wrap the thread by a suitable sealing material (Use conductive sealing material only).



**Probe with Tri-Clamp, sanitary connection or flange**

- The process seal must meet the specifications of the application (resistant to temperature and medium).
- If the flange is PTFE-clad, this generally suffices as the seal up to the permitted operating pressure.

**Probe with PTFE-clad flange**

Note!

Use spring washers (1).

It is recommended to retighten the flange bolts periodically, depending on process temperature and pressure. Recommended torque: 60 to 100 Nm.

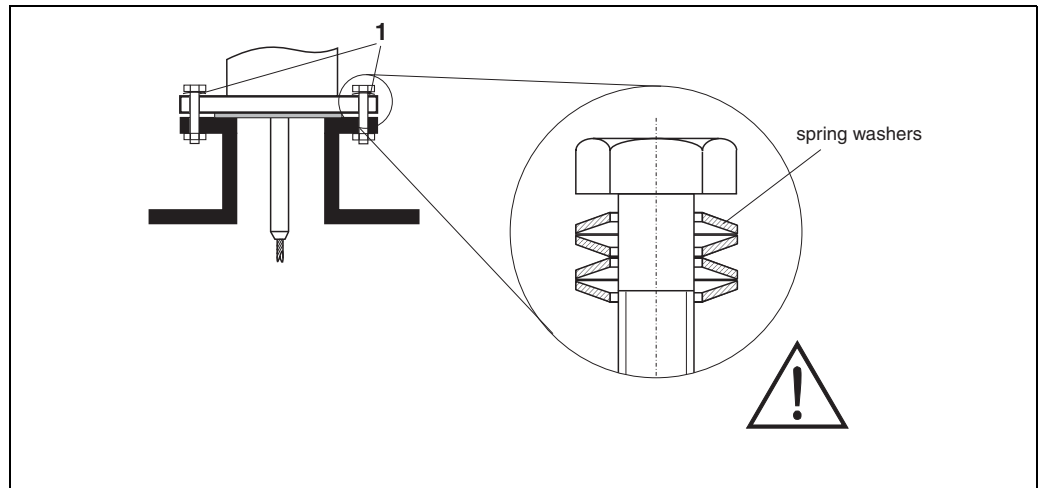

L00-FMI5xxxx-17-00-00-en-005

**3.8.1 Aligning the housing**

The housing can be rotated 270° to align the cable entry.

For an even better way of preventing moisture penetration, we recommend you route the connecting cable downwards before the cable gland and secure it with a cable tie. This is particularly recommended when mounting outdoors.

Housing

- Unscrew cover
- Loosen Phillips screw at bottom of housing by turning the screw 3 to 4 times
- Turn the housing to the desired position (max. 270°, from one stop to the next)
- Tighten Phillips screw at bottom of housing.



Note!

For housing type T13 with a separate connection compartment, the Phillips screw for aligning the housing is also located in the electronics compartment.

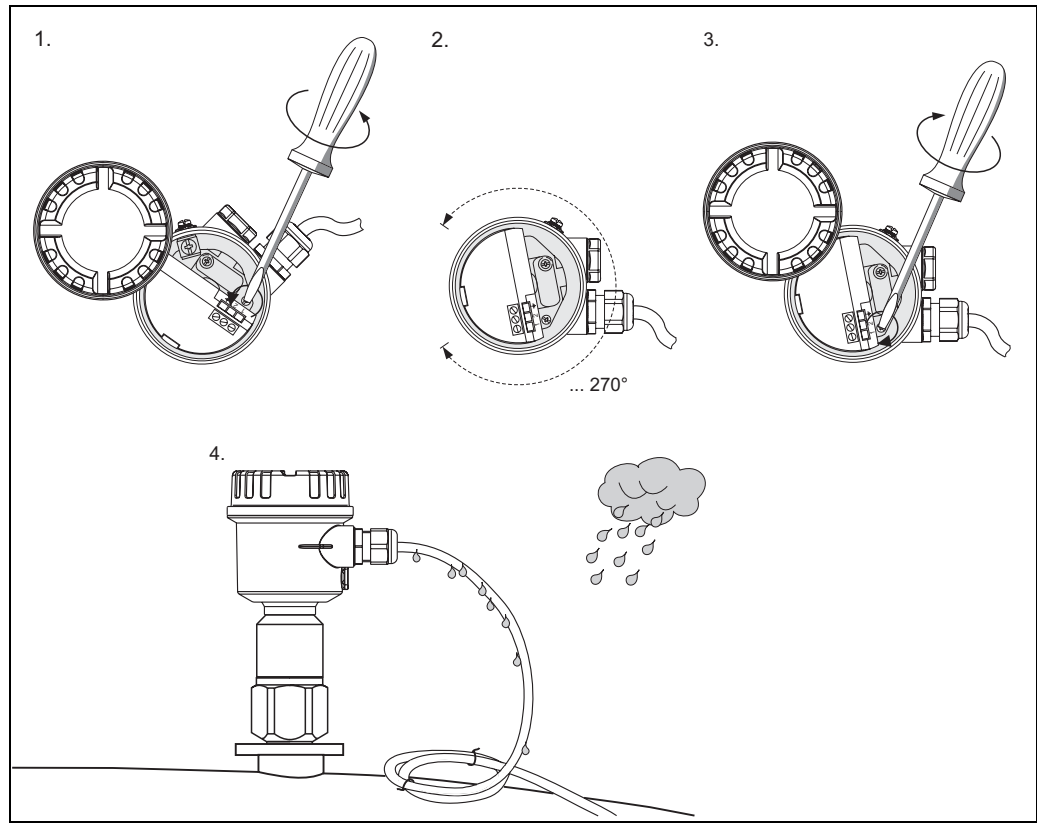

1. Loosen clamping screw until the housing rotates easily.
2. Align the housing.
3. Tighten clamping screw ( $< 1 \text{ Nm}$ ) until the housing can no longer be rotated.
4. Additional protection against moisture penetration for electronics compartment.

### 3.8.2 Sealing the probe housing

No water should enter the device when performing installation, connection and configuration tasks. Always seal the housing cover and cable entries securely.

The O-ring seal on the housing cover is shipped with a coat of special lubricant applied. In this way, the cover can be sealed tight and the aluminum thread does not bite when screwing down. Never use mineral oil-based grease as this destroys the O-ring.

## 3.9 Post-installation check

After installing the measuring device, carry out the following checks:

- Is the device damaged (visual inspection)?
- Does the device meet the specifications at the measuring point with regard to process temperature/pressure, ambient temperature, measuring range etc.?
- Has the process connection been tightened with the appropriate tightening torque?
- Are the measuring point number and labeling correct (visual inspection)?
- Is the device adequately protected against precipitation and direct sunshine?

### 3.9.1 Measuring range

- Measuring frequency: 500 kHz
- Span:  $\Delta C = 25$  to 4000 pF recommended (2 to 4000 pF possible)
- Final capacitance:  $C_E = \text{max. } 4000 \text{ pF}$
- Adjustable initial capacitance:
  - $C_A = 0$  to 2000 pF ( $< 6 \text{ m}$  probe length)
  - $C_A = 0$  to 4000 pF ( $> 6 \text{ m}$  probe length)

## 4 Wiring



Caution!

Before connecting the supply voltage, note the following:

- The supply voltage must match the data specified on the nameplate (1).
- Switch off the supply voltage before connecting the device.
- Connect the potential equalization to the ground terminal on the sensor.



Note!

- When using the probe in hazardous areas, the relevant national standards and the information in the safety instructions (XA) must also be observed.
- Use the specified cable gland only.

### 4.1 Recommendations for connection

#### 4.1.1 Potential equalization



Caution!

In Ex-applications, the screen may only be grounded on the sensor side.

Connect the potential equalization to the outer ground terminal of the housing.

In the case of the stainless steel housing F15, the ground terminal (depending on the version) can also be located in the housing.

For further safety instructions, please refer to the separate documentation for applications in hazardous areas.

#### 4.1.2 Electromagnetic compatibility (EMC)

Interference emission to EN 61326, Electrical Equipment Class B. Interference immunity to EN 61326, Annex A (Industrial) and NAMUR Recommendation NE 21 (EMC).

#### 4.1.3 Cable specification

The electronic inserts can be connected using commercially available instrument cables.

When using shielded instrument cables, it is recommended to connect the shielding on both sides to optimize the shielding effect (if potential equalization is present).

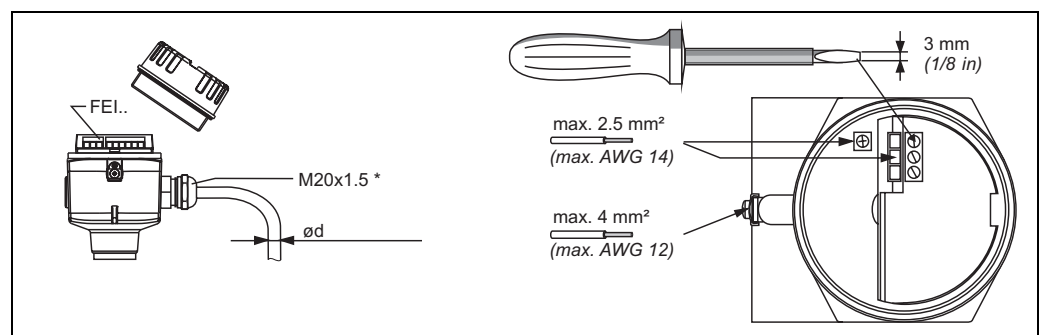

\* Cable entries

Nickel-plated brass:  $\varnothing d = 7$  to  $10.5$  mm (0.28 to 0.41 in)

Synthetic material:  $\varnothing d = 5$  to  $10$  mm (0.2 to 0.38 in)

Stainless steel:  $\varnothing d = 7$  to  $12$  mm (0.28 to 0.47 in)

#### 4.1.4 Connector

For the version with a connector M12, the housing does not have to be opened for connecting the signal line.

##### PIN assignment for plug M12

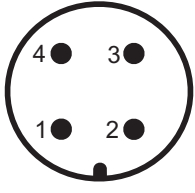
 <p>L00-FI15xxxx-04-00-xx-xx-015</p>	PIN	2-Wire Electronic Insert FEI57C
	1	+
	2	not used
	3	-
	4	ground

## 4.2 Wiring and connecting

### Connection compartment

Determining the explosion protection:

Housing	Standard	Ex ia	Ex d	Gas-tight process seal
Polyester housing F16	X	X	-	-
Stainless steel housing F15	X	X	-	-
Aluminum housing F17	X	X	-	-
Aluminum housing F13	X	X	X	X
Stainless steel housing F27	X	X	X	X
Aluminum housing T13 (with separate connection compartment)	X	X	X	X

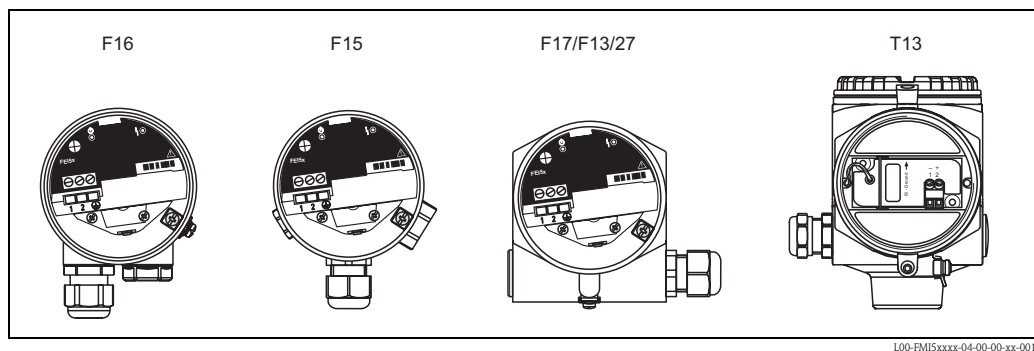

To connect the electronic insert to the power supply, proceed as follows:

- a. Unscrew the housing cover (1).
- b. Release the cable gland (2) and insert the cable (3).

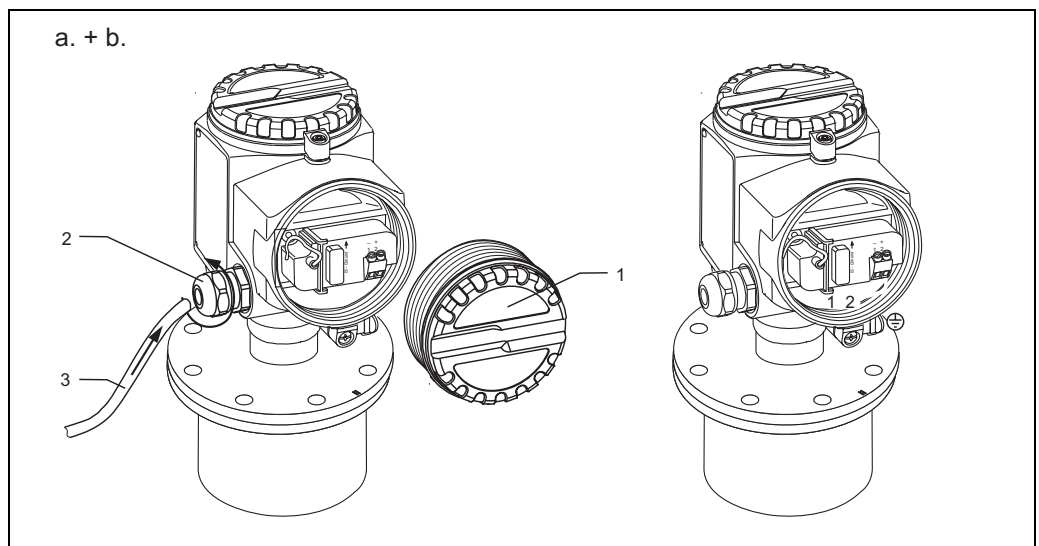
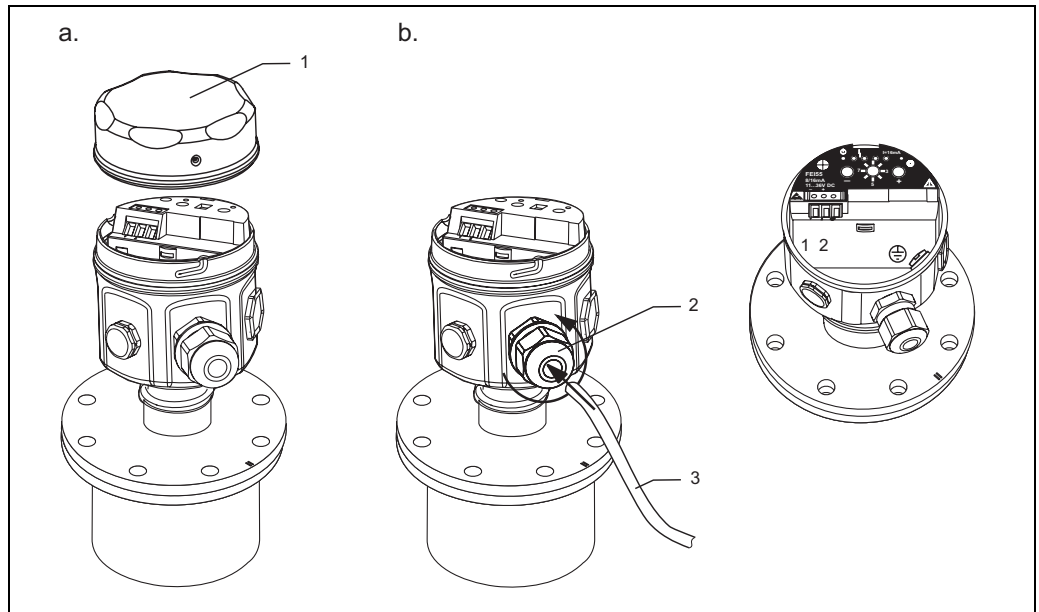

Information on connecting shielded cables is provided in TI241 "EMC test procedures".

### Cable entry

Cable gland: M20x1.5

Cable entry: G ½ or NPT ½, NPT ¾

### Supply voltage

14.8 V DC from associated supply unit (e.g. FMC662)

### Power consumption

Approx. 150 mW

### Current consumption

Max. 10 mA

### 4.2.1 Connecting the FEI57C to Silometer FMX570

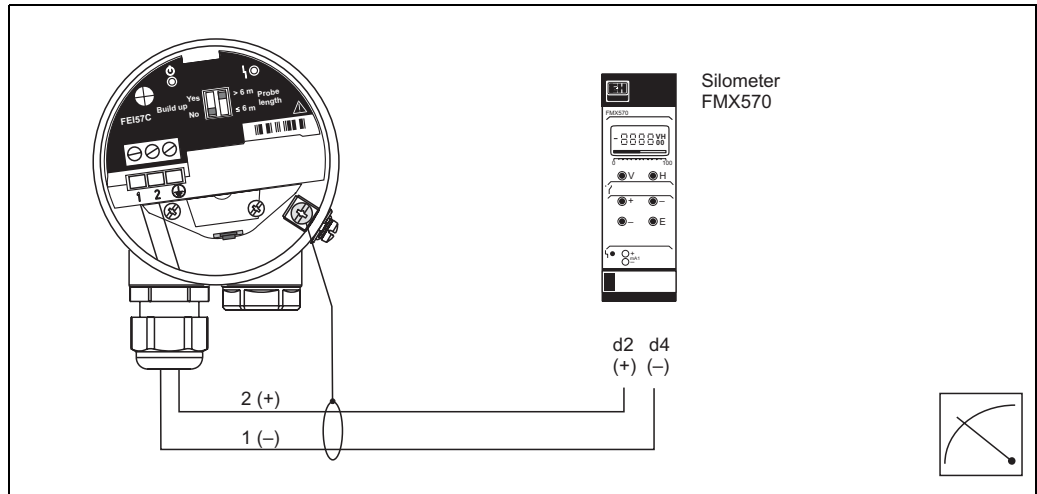

L00-FMISxxxx-04-00-00-en-012

The Silometer FMX570 is no longer available.

### 4.2.2 Connecting the FEI57C to Silometer FMC671Z

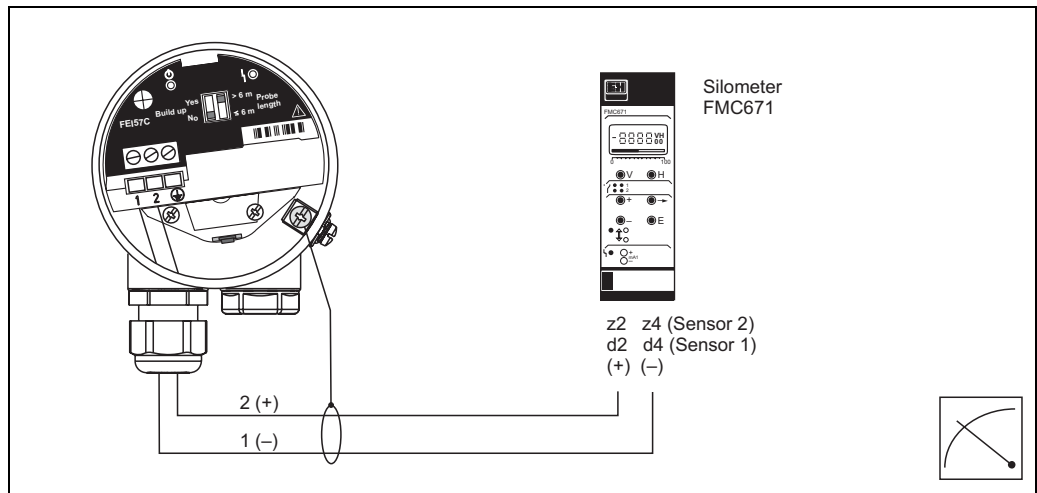

L00-FMISxxxx-04-00-00-en-013

The Silometer FMC671Z is no longer available.

### 4.2.3 Connecting the FEI57C to Prolevel FMC661, FMC662

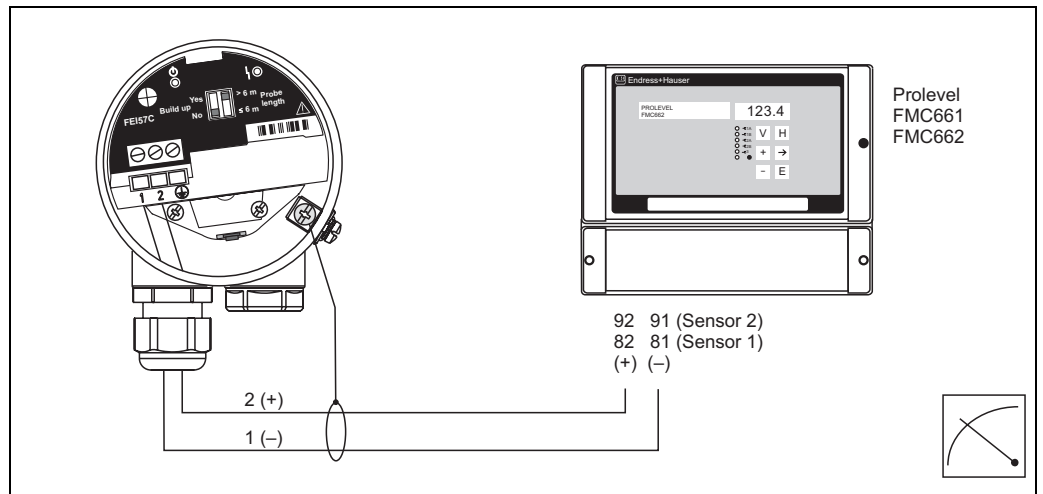

*The Prolevel FMC661 and FMC662 are no longer available.*

### 4.3 Post-connection check

After wiring the measuring device, carry out the following checks:

- Is the terminal assignment correct? (→ 30)
- Is the cable gland sealed tight?
- Is the housing cover screwed down until the stop?
- If power supply is present:
  - Is the device operational and is the green LED flashing?

## 5 Operation

### 5.1 Operating options

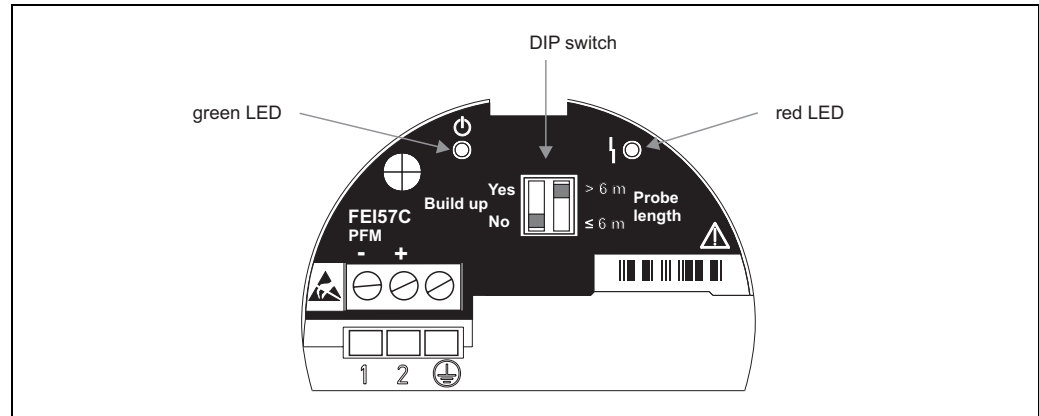

L00-FMI5xxxx-07-05-xx-en-101

### 5.2 Display and operating elements

**Green LED** (⊕ indicates operation)

- Flashes every 5 s:  
Indicates that the device is ready for operation.

**Red LED** († indicates a fault or malfunction)

- Flashes five times a second (signal: alarm):  
The PFM output outputs an error current signal and sets the output of the connected switching unit to 3.6 mA or 22 mA. The switching unit then outputs an alarm itself.
- Flashes once a second (signal: warning):  
The temperature in the electronic insert is outside the permitted temperature range.

**DIP switch** (build up YES/NO)

- Build up YES:  
This setting is recommended for media that cause heavy buildup, e.g. honey.
- Build up NO:  
This setting is recommended for media that do not cause buildup, e.g. water.

**DIP switch** (probe length > 6 m, < 6 m)

- Rope probe length > 6 m:  
Measuring range 0 to 4000 pF
- Rope probe length < 6 m:  
Measuring range 0 to 2000 pF
- Rod probe 0 to 2000 pF at ≤ 4000 mm

### 5.3 Error messages



The red LED signals the error messages.



## 6 Commissioning

### 6.1 Function check

Make sure that the post-installation check and final check have been completed before you start your measuring point:

- For the "Post-installation check" checklist, see →  26
- For the "Post-connection check" checklist, see →  31

### 6.2 Transmitter



Note!

- Please note that the settings on the electronic insert affect the function of the switching unit.
- For further commissioning, please refer to the Operating Instructions of the transmitter power supply unit. The device documentation of these devices is also available for download at [www.endress.com](http://www.endress.com) => Download => e.g. product root: FMX570.

## 7 Maintenance

No special maintenance work is required for the Liquicap M level transmitter.

### External cleaning

When externally cleaning Liquicap M, make sure that the cleaning agent used does not attack or corrode the housing surface or seals.

### Cleaning the probe

Depending on the application, buildup (contamination and soiling) can form on the probe rod. A high degree of material buildup can affect the measurement result. If the medium tends to create a high degree of buildup, regular cleaning is recommended. When hosing down or during mechanical cleaning, it is important to make sure that the insulation of the probe rod is not damaged. If cleaning agents are used make sure the material is resistant to them!

### Seals

The process seals of the sensor should be replaced periodically, especially when using molded seals (aseptic version)! The intervals between seal replacement depend on the frequency of the cleaning cycles and on the fluid and cleaning temperature.

### Repair

The Endress+Hauser repair concept is devised in such a way that the devices have a modular design and repairs can be carried out by the customers.

Spare parts are grouped into handy kits with related replacement instructions. The "Spare parts" section lists all the spare part kits, including the order numbers, which you can order from Endress+Hauser for repairing Liquicap M. For further information on service and spare parts, please contact Endress+Hauser Service.

### Repairing Ex-certified devices

The following information also has to be taken into account when repairing Ex-certified devices:

- Ex-certified devices may only be repaired by experienced, skilled staff or by Endress+Hauser Service.
- Applicable standards, national Ex-area regulations as well as the Safety Instructions (XA) and certificates must be observed.
- Only genuine spare parts from Endress+Hauser may be used.
- When ordering spare parts, please note the device designation on the nameplate. Parts can only be replaced by the same parts.
- Repairs must be carried out in accordance with the instructions. Following a repair, the individual testing specified for the device must be carried out.
- Certified devices can only be converted to other certified device versions by Endress+Hauser Service.
- Every repair and conversion made to the device must be documented.

## 8 Accessories

### 8.1 Protective cover

For F13 and F17 housing  
Order number: 71040497

For F16 housing  
Order number: 71127760

### 8.2 Shortening set for FMI52

For Liquicap M FMI52 (no hygienic approval: EHEDG, 3A)  
Order number: 942901-0001

### 8.3 Commubox FXA195 HART

For intrinsically safe HART communication with FieldCare via the RS232C interface or USB.

### 8.4 HAW56x surge arrester

Surge arrester for limiting overvoltage in signal lines and components: see Technical Information TI401F.

### 8.5 Weld-in adapter

All the weld-in adapters available are described in the document TI00426F.  
[www.endress.com](http://www.endress.com) → Country → Download → Advanced → Documentation code → TI00426F.

## 9 Troubleshooting

### 9.1 Error analysis

Cause/error	Green LED (indicates operation) is not flashing	Red LED (indicates a fault) flashes five times a second (s)	Red LED (indicates a fault) flashes once a second (s)
Check terminal assignment between supply unit and FEI57C	X	-	-
Check supply voltage to supply unit	X	-	-
Check installation state of FEI57C	X	-	-
Measuring range exceeded => capacitance too high at the probe	-	The PFM output outputs 3210 Hz	-
Faulty probe insulation	-	The PFM output outputs 3200 Hz	-
Measuring range exceeded => probe generates a short-circuit	-	The PFM output outputs 3200 Hz	-

Cause/error	Green LED (indicates operation) is not flashing	Red LED (indicates a fault) flashes five times a second (s)	Red LED (indicates a fault) flashes once a second (s)
The temperature in the electronic insert is outside the permitted temperature range.	-	The PFM output outputs 3100 to 3190 Hz	The temperature in the electronic insert is outside the permitted temperature range.

## 9.2 Application errors

Error	Remedial action
Measured error caused by buildup on the probe	Set the DIP switch for buildup compensation to the "YES" position
Measuring range too small	Incorrect measuring range selected. Set the DIP switch for the probe length to the setting > 6 m

## 9.3 Possible measuring errors

Error	Remedial measures
Measured value is incorrect	<ol style="list-style-type: none"> <li>1. Verify empty and full calibration.</li> <li>2. Clean probe if necessary, verify probe</li> <li>3. If necessary, alter better installation position of probe (do not mount in filling curtain)</li> <li>4. Check ground from process connection to tank wall. Resistance measurement &lt; 1 Ω</li> <li>5. Check probe insulation (resistance measurement) &gt; 800 kΩ (only possible for conductive media)</li> </ol> <div style="text-align: center;"> <p>F16 housing</p> <p>Electronic insert FEI50H</p> </div> <p style="text-align: right; font-size: small;">BA298Fen080</p>
If the surface is turbulent, the measured value jumps sporadically to higher levels	Increase output damping

## 9.4 Spare Parts

An overview of the spare parts for your device is available in the internet at [www.endress.com](http://www.endress.com). To obtain information on the spare parts, proceed as follows:

1. Go to "www.endress.com" and select your country.
2. Click "Instruments".

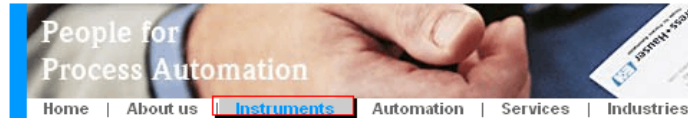

3. Enter the product name into the "product name" field.

### Endress+Hauser product search

4. Select the device.
5. Click the "Accessories/Spare parts" tab.

**Advice**  
Here you'll find a list of all available accessories and spare parts. To only view accessories and spare parts specific to your product(s), please contact us and ask about our Life Cycle Management Service.

6. Select the required spare parts (You may also use the overview drawing on the right side of the screen.)

When ordering spare parts, always quote the serial number indicated on the nameplate. As far as necessary, the spare parts also include replacement instructions.

## 9.5 Return

The following measures must be taken before returning a device to Endress+Hauser for repair:

- Remove all traces of fluid. Pay particular attention to crevices and grooves for seals into which fluid can penetrate. This is particularly important if the fluid is hazardous to health, e.g. flammable, toxic, caustic, carcinogenic etc.
- Always enclose a fully completed "Declaration of Contamination" with the device (a master copy of the "Declaration of Contamination" can be found at the end of these Operating Instructions). Only then can Endress+Hauser check or repair a returned device.
- If necessary, enclose special handling instructions when returning the device, e.g. a safety data sheet in accordance with EN 91/155/EEC.

In addition, specify the following:

- The chemical and physical properties of the fluid
- A description of the application
- A description of the error that occurred (give error code where applicable)
- Operating time of the device

## 9.6 Disposal

When disposing of the device, make sure the device components are separated based on the materials used and recycled where possible.

## 9.7 Software history

Software-Version / Date	Software updates	Documentation
FW: V 01.00.00 / 06.2005	Original software	-
HW: V 01.00	-	-

## 9.8 Contact addresses at Endress+Hauser

On the back page of these Operating Instructions, you can find an internet address for Endress+Hauser. The web site provides contact addresses that you can use in case of any questions.

# 10 Technical data

## 10.1 Technical data: probe

### 10.1.1 Capacitance values of the probe

- Basic capacitance: approx. 18 pF

### 10.1.2 Additional capacitance

- Mount the probe at a minimum distance of 50 mm from a conductive container wall:
  - Probe rod: approx. 1.3 pF/100 mm in air
  - Probe rope: approx. 1.0 pF/100 mm in air
- Fully insulated probe rod in water:
  - Approx. 38 pF/100 mm (16 mm rod)
  - Approx. 45 pF/100 mm (10 mm rod)
  - Approx. 50 pF/100 mm (22 mm rod)
- Insulated probe rope in water: approx. 19 pF/100 mm
- Rod probe with ground tube:
  - Insulated probe rod: approx. 6.4 pF/100 mm in air
  - Insulated probe rod: approx. 38 pF/100 mm in water (16 mm rod)
  - Insulated probe rod: approx. 45 pF/100 mm in water (10 mm rod)

### 10.1.3 Probe lengths for continuous measurement in conductive liquids

- Rod probe (range 0 to 2000 pF at  $\leq 4000$  mm)
- Rope probe < 6 m (range 0 to 2000 pF)
- Rope probe > 6 m (range 0 to 4000 pF)

## 10.2 Input

### 10.2.1 Measured variable

Continuous measurement of change in capacitance between probe rod and container wall or ground tube, depending on the level of the liquid.

Probe covered => high capacitance

Probe not covered => low capacitance

### 10.2.2 Measuring range

- Measuring frequency: 500 kHz
- Span:  $\Delta C = 25$  to 4000 pF recommended (2 to 4000 pF possible)
- Final capacitance:  $C_E = \text{max. } 4000$  pF
- Adjustable initial capacitance:
  - $C_A = 0$  to 2000 pF (< 6 m probe length)
  - $C_A = 0$  to 4000 pF (> 6 m probe length)

## 10.3 Output

### 10.3.1 Output signal

The transmitter superimposes current pulses (PFM signal 60 to 2800 Hz) with a pulse width of approx. 100  $\mu\text{s}$  and a current strength of approx. 8 mA on the supply current (approx. 8 mA).

### 10.3.2 Signal on alarm

Fault diagnosis can be called up via:

- Local display: red LED
- Local display at switching unit

### 10.3.3 Linearization

Linearization is performed in the transmitters.

## 10.4 Performance characteristics

### 10.4.1 Reference operating conditions

- Room temperature:  $+20$  °C  $\pm 5$  °C
- Span
  - Standard measuring range: 5 to 2000 pF
  - Extended measuring range: 5 to 4000 pF
  - Span for reference: 5 to 4000 pF (corresponds to approx. 1 m probe length)

### 10.4.2 Maximum measured error

- Non-repeatability (reproducibility) as per DIN 61298-2: max.  $\pm 0.1$  %
- Non-linearity for limit point setting (linearity) as per DIN 61298-2: max.  $\pm 0.5$  %

### 10.4.3 Influence of ambient temperature

**Electronic insert**

< 0.06 %/10 K related to the full scale value

**Separate housing**

Change in capacitance of connecting cable 0.015 pF/m per K

### 10.4.4 Switch-on behavior

**FEI57C**

1.5 s (stable measured value after switch-on procedure). Start-up in safe status (22mA).

### 10.4.5 Measured value reaction time

**FEI57C**

$t_1 = 0.3$  s

Note!

Observe integration time of switching unit

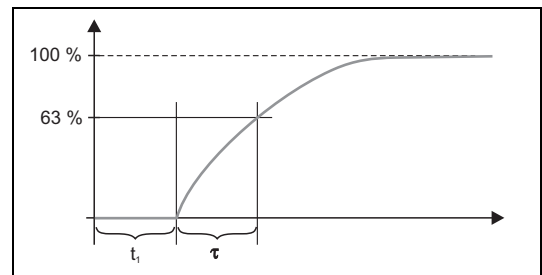

L00-FMI5xxx-05-05-xx-xx-009

$\tau =$  Output damping  
 $t_1 =$  Dead time



### 10.4.6 Accuracy of factory calibration

	Probe length < 2 m	Probe length > 2 m
Empty calibration (0 %)	≤ 5 mm	Approx. 2 %
Full calibration (100 %)	≤ 5 mm	Approx. 2 %

Medium conductivity ≥ 100 µS/cm  
 Minimum distance to container wall = 250 mm



**Note!**

In an installed state, recalibration is only necessary if:

- The 0 % or the 100 % value have to be adjusted specifically for the customer.
- The liquid is not conductive.
- The probe distance to the tank wall is < 250 mm

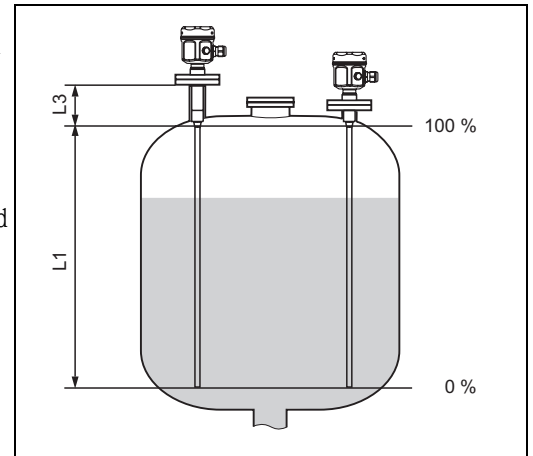

L00-FMI5xxxx-15-05-xx-xx-002

### 10.4.7 Resolution

**FEI57C**

- Zero frequency  $f_0$  60 Hz:  
 Sensitivity of the electronic insert = 0.685 Hz/pF  
 Entry in switching unit FMC671 under V3H5 and V3H6 or V7H5 and V7H6

## 10.5 Power supply

### 10.5.1 Electrical connection

**Connection compartment**

Five types of housing are available:

	Standard	Ex ia	Ex d	Gas-tight process seal
Polyester housing F16	X	X	–	–
Stainless steel housing F15	X	X	–	–
Aluminum housing F17	X	X	–	–
Aluminum housing F13	X	X	–	X
Aluminum housing T13 (with separate connection compartment)	X	X	–	X

### 10.5.2 Terminal assignment

#### 2-wire, PFM

The twin-core, shielded connecting cable with a cable resistance of max. 50 Ω is connected to the screw terminals (conductor cross-section 0.5 to 2.5 mm) in the connection compartment. The shielding must be connected at the sensor and power supply. Protective circuits against reverse polarity, HF influences and overvoltage peaks are integrated (see TI00241F "EMC test procedures").

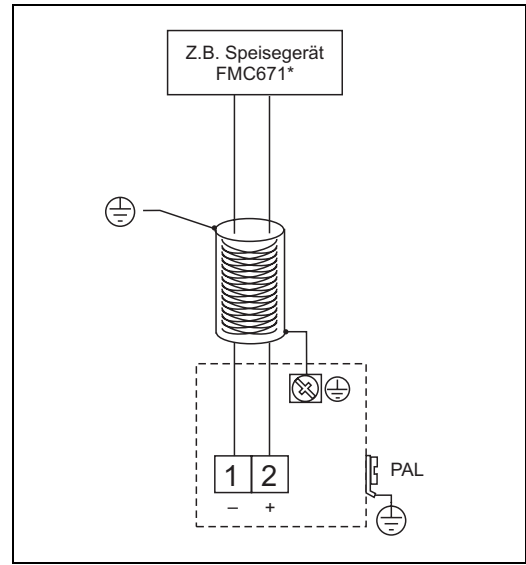

\* Product discontinued at end of 2006.

### 10.5.3 Supply voltage

The following voltage is the terminal voltage directly at the device:

- 14.8 V DC from associated supply unit (e.g. FMC662)



Note!

The electronic insert has integrated reverse polarity protection.

### 10.5.4 Cable entry

- Cable gland: M20x1.5
- Cable entry: G ½ or NPT ½, NPT ¾

### 10.5.5 Power consumption

Max. 250 mW

### 10.5.6 Current consumption

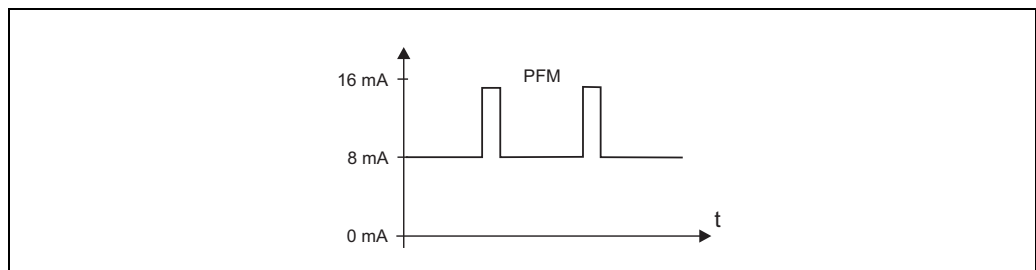

Frequency: 60 to 2800 Hz

## 10.6 Operating conditions: Environment

### 10.6.1 Ambient temperature range

- -50 to +70 °C
- -40 to +70 °C (with F16 housing)

- Observe derating → 44
- If operating outdoors, use a protective cover! → 35.

### 10.6.2 Storage temperature

–50 to +85 °C

### 10.6.3 Climate class

DIN EN 60068-2-38/IEC 68-2-38: Z/AD check

### 10.6.4 Vibration resistance

DIN EN 60068-2-64/IEC 68-2-64: 20 Hz– 2000 Hz; 0.01 g<sup>2</sup>/Hz

### 10.6.5 Shock resistance

DIN EN 60068-2-27/IEC 68-2-27: 30g acceleration

### 10.6.6 Cleaning

#### Housing:

When cleaning, make sure that the cleaning agent used does not attack or corrode the housing surface or seals.

#### Probe:

Depending on the application, buildup (contamination and soiling) can form on the probe rod. A high degree of material buildup can affect the measurement result. If the medium tends to create a high degree of buildup, regular cleaning is recommended. When hosing down or during mechanical cleaning, it is important to make sure that the insulation of the probe rod is not damaged.

### 10.6.7 Degree of protection

	IP66*	IP67*	IP68*	NEMA4X*
Polyester housing F16	X	X	–	X
Stainless steel housing F15	X	X	–	X
Aluminum housing F17	X	X	–	X
Aluminum housing F13 with gas-tight process seal	X	–	X***	X
Stainless steel housing F27 with gas-tight process seal	X	X	X***	X
Aluminum housing T13 with gas-tight process seal and separate connection compartment (Ex d)	X	–	X***	X
Separate housing	X	–	X***	X

\* As per EN60529

\*\* As per NEMA 250

\*\*\* Only with M20 cable entry or G1/2 thread

### 10.6.8 Electromagnetic compatibility (EMC)

- Interference emission to EN 61326, Electrical Equipment Class B  
Interference immunity to EN 61326, Annex A (Industrial) and NAMUR Recommendation NE 21 (EMC)
- A usual commercial instrument cable can be used.

## 10.7 Operating conditions: Process

### 10.7.1 Process temperature range

The following diagrams apply for:

- Rod and rope version
- Insulation: PTFE, PFA, FEP
- Standard applications outside hazardous areas



Note!

The temperature is restricted to  $T_a -40\text{ °C}$  if the polyester housing F16 is used and if additional option B is selected (free from paint-wetting impairment substances, FMI51).

#### With compact housing

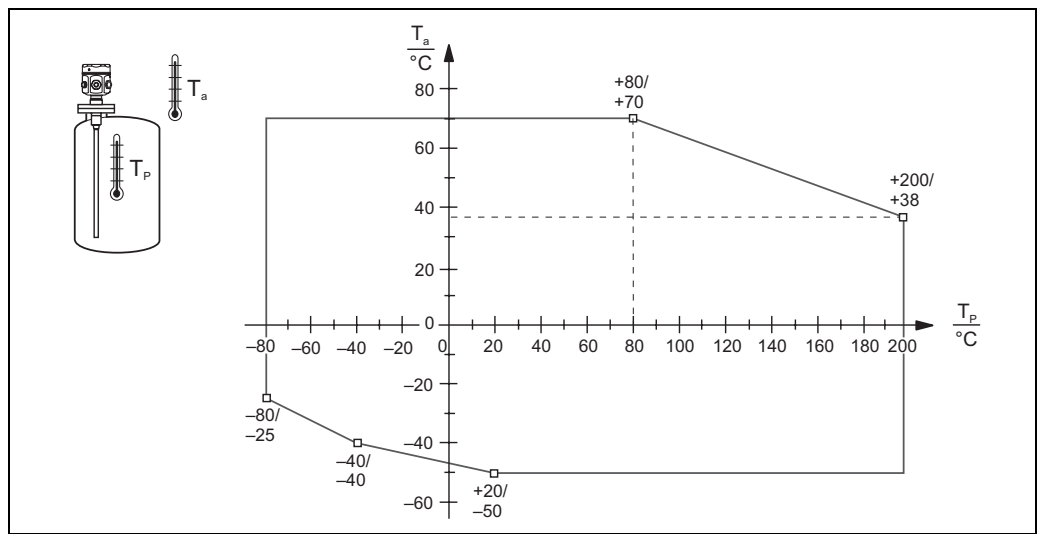

$T_a$ : Ambient temperature  
 $T_P$ : Process temperature

#### With separate housing

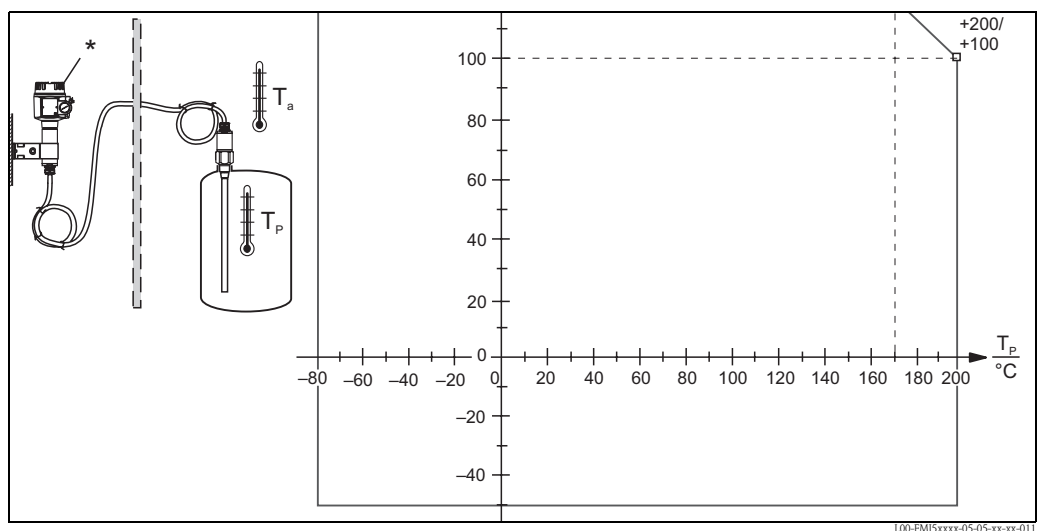

$T_a$  = Ambient temperature  
 $T_P$  = Process temperature

\* The permitted ambient temperature at the separate housing is the same as indicated for the compact housing → 44.

## 10.7.2 Process pressure limits

### Probe $\varnothing 10$ mm (including insulation)

-1 to 25 bar

### Probe $\varnothing 16$ mm (including insulation)

- -1 to 100 bar
- In the event of an inactive length, the maximum permitted process pressure is 63 bar
- In the event of CRN approval and inactive length, the maximum permitted process pressure is 32 bar.

### Probe $\varnothing 22$ mm (including insulation)

-1 to 50 bar

Refer to the following standards for the pressure values permitted at higher temperatures:

- EN 1092-1: 2005 Table, Appendix G2  
With regard to its resistance/temperature property, the material 1.4435 is identical to 1.4404 (AISI 316L) which is grouped under 13E0 in EN 1092-1 Tab. 18. The chemical composition of the two materials can be identical.
- ASME B 16.5a - 1998 Tab. 2-2.2 F316
- ASME B 16.5a - 1998 Tab. 2.3.8 N10276
- JIS B 2220

The lowest value from the derating curves of the device and the selected flange applies.

## 10.7.3 Pressure and temperature derating

**For process connections  $\frac{1}{2}$ ",  $\frac{3}{4}$ ", 1", flanges < DN50, < ANSI 2", < JIS 10K (10 mm rod)**

**For process connections  $\frac{3}{4}$ ", 1", flanges < DN50, < ANSI 2", < JIS 10K (16 mm rod)**

Rod insulation: PTFE, PFA

Rope insulation: FEP, PFA

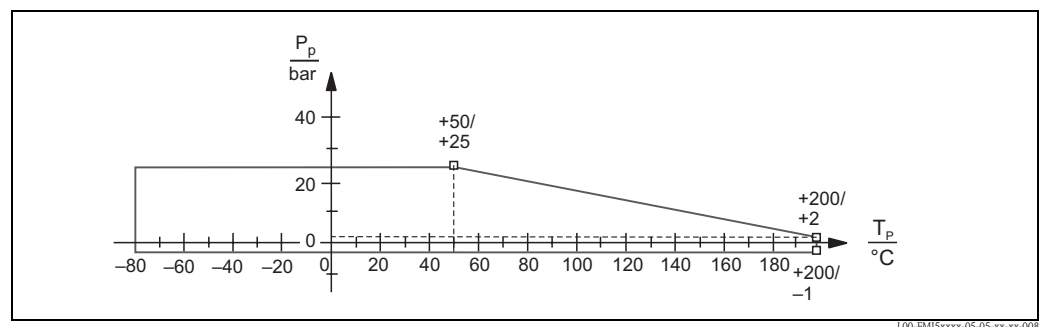

$P_p$  : Process pressure

$T_p$  : Process temperature

**For process connections  $1\frac{1}{2}$ ", flanges  $\geq$  DN50,  $\geq$  ANSI 2",  $\geq$  JIS 10K (16 mm rod)**

Rod insulation: PTFE, PFA

Rope insulation: FEP, PFA

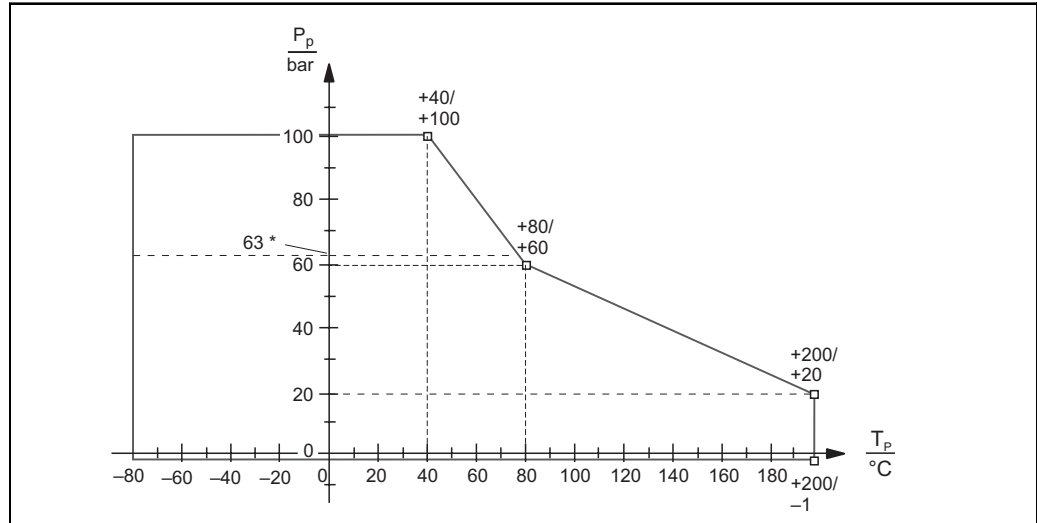

L00-FMI5xxxx-05-05-xx-xx-012

*Pp* : process pressure  
*Tp* : process temperature  
 \* For probes with an inactive length .

**With a fully insulated inactive length (22 mm rod):**

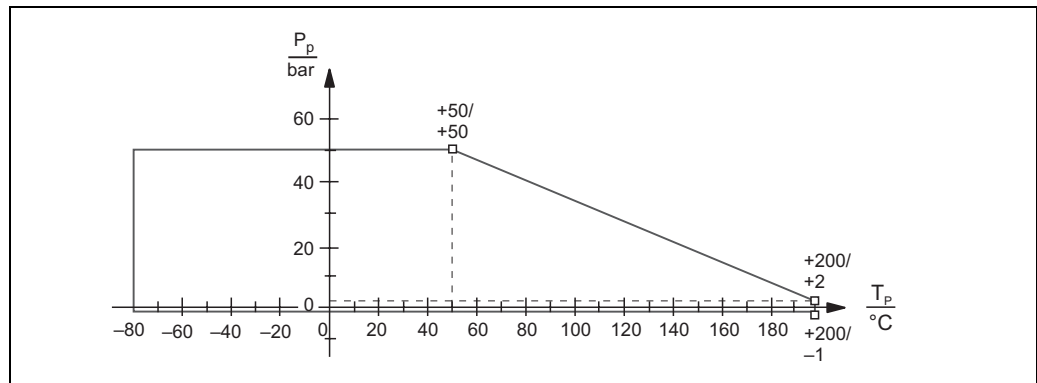

L00-FMI5xxxx-05-05-xx-xx-012

*Pp* : Process pressure  
*Tp* : Process temperature

## 10.8 Certificates and approvals

### 10.8.1 Other standards and guidelines

**EN 60529**

Degrees of protection by housing (IP code)

**EN 61010**

Protection measures for electrical equipment for measurement, control, regulation and laboratory procedures

**EN 61326**

Interference emission (Class B equipment), interference immunity (Annex A - Industrial).

**NAMUR**

Association for Standards for Control and Regulation in the Chemical Industry

**IEC 61508**

Functional safety

## 10.8.2 Other approvals

- See also "Identification" on → 5 ff.
- TSE Certificate of Suitability (FMI51)  
The following applies to wetted device components:
  - They do not contain any materials derived from animals.
  - No additives or operating materials derived from animals are used in production or processing.
- 📎 Note!  
The wetted device components are listed in the "Identification" section (→ 5 ff.).
- AD2000  
The wetted material (316L) corresponds to AD2000 – W0/W2

## 10.9 Documentation

### 10.9.1 Technical Information

- Liquicap M FMI51, FMI52  
TI00401F/00

### 10.9.2 Certificates

#### ATEX safety instructions

- Liquicap M FMI51, FMI52  
ATEX II 1/2 G Ex ia IIC/IIB T3 to T6, II 1/2 D IP65 T 85 °C  
XA00327F/00/a3
- Liquicap M FMI51, FMI52  
ATEX II 1/2 G Ex d [ia] IIC/IIB T3 to T6  
XA00328F/00/a3
- Liquicap M FMI51, FMI52  
Ga/Gb Ex ia IIC T6 to T3; Ex ia D 20 / Ex tD A21 IP65 T90°C  
XA00423F/00/a3

#### NEPSI safety instructions

- Liquicap M FMI51, FMI52  
Ex ia IIC/IIB T3 to T6  
XA00417F/00/a3
- Liquicap M FMI51, FMI52  
Ex d [ia] IIC/IIB T3 to T6  
XA00418F/00/a3
- Liquicap M FMI51, FMI52  
Ex nA II T3 to T6, Ex nC IIC T3 to T6  
XA00430F/00/a3

#### Overfill protection DIBt (WHG)

- Liquicap M FMI51, FMI52  
ZE00265F/00/en

#### Functional safety (SIL2)

- Liquicap M FMI51, FMI52  
SD00198F/00/en

**Control Drawings (CSA and FM)**

- Liquicap M FMI51, FMI52  
FM  
ZD00220F/00/en
- Liquicap M FMI51, FMI52  
CSA  
ZD00221F/00/en

**CRN registration**

- CRN 0F1988.75

**10.9.3 Patents**

This product is protected by at least one of the following patents.  
Further patents are pending.

- DE 103 22 279,  
WO 2004 102 133,  
US 2005 003 9528
- DE 203 13 695,  
WO 2005 025 015



# Index

## A

- Accessories ..... 35
- Aligning the housing ..... 25

## C

- Cable specification ..... 27
- Calibration error ..... 36
- CE mark ..... 12
- Certificates and approvals ..... 46–47
- Commissioning ..... 33
- Commubox ..... 30, 35
- Commubox FXA191/195 HART ..... 35
- Commuwin II ..... 30
- Connection ..... 28, 30–31

## D

- Declaration of Conformity ..... 12
- Declaration of Contamination ..... 37
- Designated use ..... 3
- Disposal ..... 38
- DXR375 ..... 30

## E

- Electrical symbols ..... 4
- Electromagnetic compatibility (EMC) ..... 27
- Error messages ..... 32
- Ex area ..... 3
- External cleaning ..... 34

## F

- Fieldbus connector ..... 28
- FXA191 ..... 30
- FXA193 ..... 30

## G

- Ground tube ..... 17

## H

- HART ..... 30

## I

- Identification ..... 5
- Inactive length ..... 17
- Incoming acceptance ..... 13
- Installation ..... 13

## M

- Maintenance ..... 34
- Marine approval (GL) ..... 15
- Measuring condition ..... 15
- Measuring range ..... 26

## N

- Nameplate ..... 5
- Notes on safety conventions and icons ..... 4

## O

- Operating menus ..... 32
- Operation ..... 32
- Operational safety ..... 3
- Orientation ..... 14

## P

- Pipe mounting ..... 22
- Planning instructions ..... 14
- Post-connection check ..... 31
- Post-installation check ..... 26
- Potential equalization ..... 27
- Protective cover ..... 35

## R

- Repair ..... 34
- Repairing Ex-certified devices ..... 34
- Return ..... 37
- RMA422 ..... 30
- RN221N ..... 30
- Rod probes ..... 16
- Rope probes ..... 19
- Rotating the housing ..... 25

## S

- Safety instructions ..... 3–4
- Sealing (housing) ..... 26
- Seals ..... 34
- Separate housing ..... 21
- Separate housing (shortening the connecting cable) ..... 23
- Shortening set ..... 35
- Shortening the rope ..... 20
- Spare Parts ..... 37
- Storage ..... 13
- Storage temperature ..... 13

## T

- Technical data ..... 38
- Tensioning weight with tension ..... 20
- ToF Tool ..... 30
- Troubleshooting ..... 35
- Type of protection ..... 4

## W

- Wall bracket ..... 22
- Wall mounting ..... 22
- Wiring ..... 27



## Declaration of Hazardous Material and De-Contamination *Erklärung zur Kontamination und Reinigung*

**RA No.**

Please reference the Return Authorization Number (RA#), obtained from Endress+Hauser, on all paperwork and mark the RA# clearly on the outside of the box. If this procedure is not followed, it may result in the refusal of the package at our facility.

*Bitte geben Sie die von E+H mitgeteilte Rücklieferungsnummer (RA#) auf allen Lieferpapieren an und vermerken Sie diese auch außen auf der Verpackung. Nichtbeachtung dieser Anweisung führt zur Ablehnung ihrer Lieferung.*

Because of legal regulations and for the safety of our employees and operating equipment, we need the "Declaration of Hazardous Material and De-Contamination", with your signature, before your order can be handled. Please make absolutely sure to attach it to the outside of the packaging.

*Aufgrund der gesetzlichen Vorschriften und zum Schutz unserer Mitarbeiter und Betriebseinrichtungen, benötigen wir die unterschriebene "Erklärung zur Kontamination und Reinigung", bevor Ihr Auftrag bearbeitet werden kann. Bringen Sie diese unbedingt außen an der Verpackung an.*

**Type of instrument / sensor**

Geräte-/Sensortyp \_\_\_\_\_

**Serial number**

Seriennummer \_\_\_\_\_

**Used as SIL device in a Safety Instrumented System / Einsatz als SIL Gerät in Schutzeinrichtungen**

**Process data / Prozessdaten**

Temperature / Temperatur \_\_\_\_\_ [°F] \_\_\_\_\_ [°C] Pressure / Druck \_\_\_\_\_ [psi] \_\_\_\_\_ [Pa]  
Conductivity / Leitfähigkeit \_\_\_\_\_ [µS/cm] Viscosity / Viskosität \_\_\_\_\_ [cp] \_\_\_\_\_ [mm<sup>2</sup>/s]

**Medium and warnings**

Warnhinweise zum Medium



	Medium / concentration <i>Medium / Konzentration</i>	Identification CAS No.	flammable <i>entzündlich</i>	toxic <i>giftig</i>	corrosive <i>ätzend</i>	harmful/ irritant <i>gesundheitsschädlich/ reizend</i>	other * <i>sonstiges*</i>	harmless <i>unbedenklich</i>
Process medium <i>Medium im Prozess</i>								
Medium for process cleaning <i>Medium zur Prozessreinigung</i>								
Returned part cleaned with <i>Medium zur Endreinigung</i>								

\* explosive; oxidising; dangerous for the environment; biological risk; radioactive

\* *explosiv; brandfördernd; umweltgefährlich; biogefährlich; radioaktiv*

Please tick should one of the above be applicable, include safety data sheet and, if necessary, special handling instructions.

*Zutreffendes ankreuzen; trifft einer der Warnhinweise zu, Sicherheitsdatenblatt und ggf. spezielle Handhabungsvorschriften beilegen.*

**Description of failure / Fehlerbeschreibung** \_\_\_\_\_

**Company data / Angaben zum Absender**

Company / Firma _____	Phone number of contact person / Telefon-Nr. Ansprechpartner: _____
Address / Adresse _____	Fax / E-Mail _____
_____	Your order No. / Ihre Auftragsnr. _____

"We hereby certify that this declaration is filled out truthfully and completely to the best of our knowledge. We further certify that the returned parts have been carefully cleaned. To the best of our knowledge they are free of any residues in dangerous quantities."

*"Wir bestätigen, die vorliegende Erklärung nach unserem besten Wissen wahrheitsgetreu und vollständig ausgefüllt zu haben. Wir bestätigen weiter, dass die zurückgesandten Teile sorgfältig gereinigt wurden und nach unserem besten Wissen frei von Rückständen in gefährlicher Menge sind."*

(place, date / Ort, Datum)

Name, dept./Abt. (please print / bitte Druckschrift)

Signature / Unterschrift

[www.endress.com/worldwide](http://www.endress.com/worldwide)

---

**Endress+Hauser**   
People for Process Automation

