

# Operating Instructions

## Tankvision

### NXA820, NXA821, NXA822

#### Installation Instructions

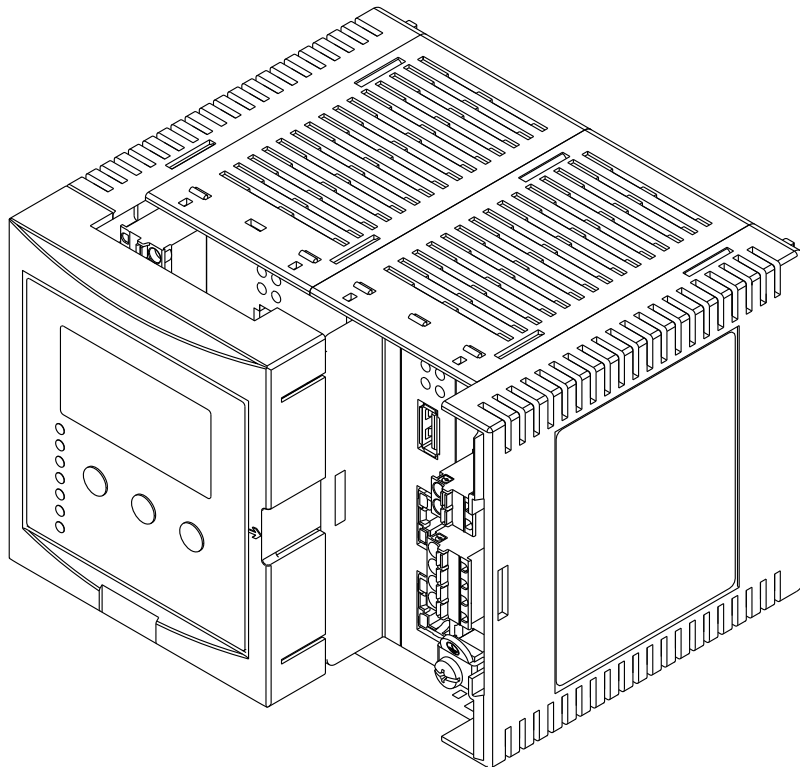

# Table of Contents

|          |   |           |           |  |           |
|----------|---|-----------|-----------|--|-----------|
| <b>1</b> | <b>Document information</b> . . . . .   | <b>3</b>  | <b>9</b>  | <b>Tankvision NXA820 (Interface only) Configuration</b> . . . . .    | <b>41</b> |
| 1.1      | Target audience for this manual . . . . .   | 3         | 9.1       | Logging into the Tankvision NXA820 (Interface only) system . . . . . | 41        |
| 1.2      | Version history . . . . .   | 3         | 9.2       | Overview - Tankvision NXA820 (Interface only) system . . . . .       | 42        |
| 1.3      | Document function . . . . .   | 3         | 9.3       | Configuration - Tankvision NXA820 (Interface only) system . . . . .  | 42        |
| 1.4      | Documentation . . . . .   | 4         | 9.4       | Service - Tankvision NXA820 (Interface only) . . . . .               | 54        |
| <b>2</b> | <b>Basic safety instructions</b> . . . . .  | <b>5</b>  | 9.5       | Exit the Tankvision system . . . . .                                 | 55        |
| 2.1      | Requirements for the personnel . . . . .  | 5         | <b>10</b> | <b>Trouble shooting</b> . . . . .                                    | <b>56</b> |
| 2.2      | IT security . . . . .   | 5         | 10.1      | Test network connection . . . . .                                    | 56        |
| 2.3      | Designated use . . . . .  | 5         | 10.2      | Resets . . . . .   | 57        |
| 2.4      | Workplace safety . . . . .  | 6         | <b>11</b> | <b>Return</b> . . . . .  | <b>58</b> |
| 2.5      | Operational safety . . . . .  | 6         |           | <b>Index</b> . . . . .   | <b>59</b> |
| 2.6      | Product safety . . . . .  | 6         |           |  |           |
| <b>3</b> | <b>Identification</b> . . . . .   | <b>7</b>  |           |  |           |
| 3.1      | Product identification . . . . .  | 7         |           |  |           |
| 3.2      | Nameplate . . . . .   | 7         |           |  |           |
| 3.3      | Order code and device version . . . . .   | 8         |           |  |           |
| 3.4      | Registered trademarks . . . . .   | 8         |           |  |           |
| <b>4</b> | <b>Installation</b> . . . . .   | <b>9</b>  |           |  |           |
| 4.1      | Incoming acceptance, transport, storage . . . . .   | 9         |           |  |           |
| 4.2      | Mounting . . . . .  | 9         |           |  |           |
| 4.3      | Installation check . . . . .  | 10        |           |  |           |
| <b>5</b> | <b>Wiring</b> . . . . .   | <b>11</b> |           |  |           |
| 5.1      | Wiring examples . . . . .   | 11        |           |  |           |
| 5.2      | Terminal assignment . . . . .   | 12        |           |  |           |
| 5.3      | Terminal assignment Field connection - Tank Scanner NXA820 . . . . .                                | 15        |           |  |           |
| 5.4      | Terminal assignment host/printer connection - Host Link NXA822 / Data Concentrator NXA821 . . . . . | 18        |           |  |           |
| <b>6</b> | <b>Operation station settings</b> . . . . .   | <b>21</b> |           |  |           |
| 6.1      | Deactivate proxy server usage . . . . .   | 21        |           |  |           |
| 6.2      | Java Runtime Environment (JRE) . . . . .  | 22        |           |  |           |
| <b>7</b> | <b>Tankvision NXA820/821/822 User Interface</b> . . . . .   | <b>23</b> |           |  |           |
| <b>8</b> | <b>Tankvision NXA820/821/822 Configuration</b> . . . . .  | <b>27</b> |           |  |           |
| 8.1      | Logging into the Tankvision NXA820/821/822 system . . . . .   | 27        |           |  |           |
| 8.2      | Common settings - Tankvision NXA820/821/822 system . . . . .  | 28        |           |  |           |
| 8.3      | Exit the Tankvision system . . . . .  | 40        |           |  |           |

# 1 Document information

## 1.1 Target audience for this manual

This manual should support during the installation of the NXA82x units. It deals with the mechanical, electrical and signal line installation. The first commissioning steps are described as well.

Beside basic PC operating knowledge no special training is needed to perform the Tank Gauging System operations. Nevertheless it is recommended receiving a training on the system by Endress+Hauser.





## 1.2 Version history

| Document version     | Valid for SW version | Changes to the previous version                           |
|----------------------|----------------------|---|
| BA00340F/00/en/04.08 | 01.00.00 to 01.01.01 | Initial version   |
| BA00340F/00/EN/12.09 | 01.02.00 to 01.04.00 | Clarification, content revision, segmentation to BA00339F |
| BA00340G/00/EN/13.13 | 01.05.00 onwards     | Introducing "Interface only" version, new layout          |



## 1.3 Document function

### 1.3.1 Used symbols

#### Safety symbols



| Symbol  | Meaning  |
|---|--|
| <br><small>A0011189-EN</small> | <b>DANGER!</b><br>This symbol alerts you to a dangerous situation. Failure to avoid this situation will result in serious or fatal injury. |
| <br><small>A0011190-EN</small> | <b>WARNING!</b><br>This symbol alerts you to a dangerous situation. Failure to avoid this situation can result in serious or fatal injury. |
| <br><small>A0011191-EN</small> | <b>CAUTION!</b><br>This symbol alerts you to a dangerous situation. Failure to avoid this situation can result in minor or medium injury.  |
| <br><small>A0011192-EN</small> | <b>NOTICE!</b><br>This symbol contains information on procedures and other facts which do not result in personal injury.                   |

#### Electrical symbols



| Symbol   | Meaning   |
|--|---|
| <br><small>A0011197</small> | <b>Direct current</b><br>A terminal to which DC voltage is applied or through which direct current flows.                       |
| <br><small>A0011198</small> | <b>Alternating current</b><br>A terminal to which alternating voltage is applied or through which alternating current flows.    |
| <br><small>A0011200</small> | <b>Ground connection</b><br>A grounded terminal which, as far as the operator is concerned, is grounded via a grounding system. |

|  |  |
|--|--|
| <br><small>A0011199</small> | <b>Protective ground connection</b><br>A terminal which must be connected to ground prior to establishing any other connections. |
|--|--|

### Symbols for certain types of information

| Symbol   | Meaning  |
|--|--|
| <br><small>A0011193</small> | <b>Tip</b><br>Indicates additional information.                      |
| <br><small>A0011195</small> | <b>Reference to page</b><br>Refers to the corresponding page number. |
| 1. , 2. , 3. ...   | Series of steps  |
| <br><small>A0018373</small> | Result of a sequence of actions                                      |

### Symbols in graphics

| Symbol   | Meaning   |
|--|---|
| 1, 2, 3 ...  | Item numbers  |
| 1. , 2. , 3. ...   | Series of steps   |
| A, B, C ...  | Views   |
| <br><small>A0011187</small> | <b>Hazardous area</b><br>Indicates a hazardous area.                        |
| <br><small>A0011188</small> | <b>Indicates a non-hazardous location</b><br>Safe area (non-hazardous area) |

## 1.4 Documentation

### 1.4.1 Operating instructions

| Document number | Instrument  | Type of Document                    |
|-----------------|---|-------------------------------------|
| BA00339G/00     | <ul style="list-style-type: none"> <li>▪ Tank Scanner NXA820</li> <li>▪ Data Concentrator NXA821</li> <li>▪ Host Link NXA822</li> </ul> | Description of Instrument Functions |
| BA00340G/00     |   | Installation Instructions           |
| BA00424G/00     |   | System Description                  |
| BA00426G/00     |   | Operator Manual                     |
| BA01137G/00     | Tankvision NXA820 OPC Server  | User Manual                         |

## 2 Basic safety instructions

### 2.1 Requirements for the personnel

The personnel for installation, commissioning, diagnostics and maintenance must fulfill the following requirements:

- Trained, qualified specialists: must have a relevant qualification for this specific function and task
- Are authorized by the plant owner/operator
- Are familiar with federal/national regulations
- Before beginning work, the specialist staff must have read and understood the instructions in the Operating Instructions and supplementary documentation as well as in the certificates (depending on the application)
- Following instructions and basic conditions

The operating personnel must fulfill the following requirements:

- Being instructed and authorized according to the requirements of the task by the facility's owner operator
- Following the instructions in these Operating Instructions

### 2.2 IT security

We only provide a warranty if the device is installed and used as described in the Operating Instructions. The device is equipped with security mechanisms to protect it against any inadvertent changes to the device settings.

IT security measures in line with operators' security standards and designed to provide additional protection for the device and device data transfer must be implemented by the operators themselves.

Endress+Hauser can be contacted to provide support in performing this task.

### 2.3 Designated use

#### 2.3.1 Application

Tankvision is a dedicated tank inventory management system.

Components:

- Tankvision Tank Scanner NXA820  
scans parameters from tank gauges and performs tank calculations
- Tankvision Data Concentrator NXA821  
summarizes data from various Tank Scanners NXA820
- Tankvision Host Link NXA822  
provides data to host systems (such as PLC or DCS) via Modbus

The above mentioned components are operated via a standard web browser. It does not require any proprietary software. Tankvision is based on a distributed architecture on a Local Area Network (LAN). Due to its modular structure it can be adjusted to any application. It is ideally suited for small tank farms with only a couple of tanks, but also for large refineries with hundreds of tanks.

## 2.4 Workplace safety

For work on and with the device:

- Wear the required personal protective equipment according to federal/national regulations.
- Switch off the supply voltage before connecting the device.

## 2.5 Operational safety

Risk of injury!

- Operate the device in proper technical condition and fail-safe condition only.
- The operator is responsible for interference-free operation of the device.

### Conversions to the device

Unauthorized modifications to the device are not permitted and can lead to unforeseeable dangers

- If, despite this, modifications are required, consult with Endress+Hauser.

### Repair

To ensure continued operational safety and reliability,

- Carry out repairs on the device only if they are expressly permitted.
- Observe federal/national regulations pertaining to repair of an electrical device.
- Use original spare parts and accessories from Endress+Hauser only.

## 2.6 Product safety

The device is designed to meet state-of-the-art safety requirements, has been tested and left the factory in a condition in which it is safe to operate. The device complies with the applicable standards and regulations as listed in the EC declaration of conformity and thus complies with the statutory requirements of the EG directives. Endress+Hauser confirms the successful testing of the device by affixing to it the CE mark.

## 3 Identification

### 3.1 Product identification

The following options are available for identification of the measuring device:

- Nameplate specifications
- Order code with breakdown of the device features on the delivery note
- Enter serial numbers from nameplates in W@M Device Viewer (www.endress.com/deviceviewer): All information about the measuring device is displayed.

For an overview of the technical documentation provided, enter the serial number from the nameplates in the W@M Device Viewer (www.endress.com/deviceviewer)

### 3.2 Nameplate

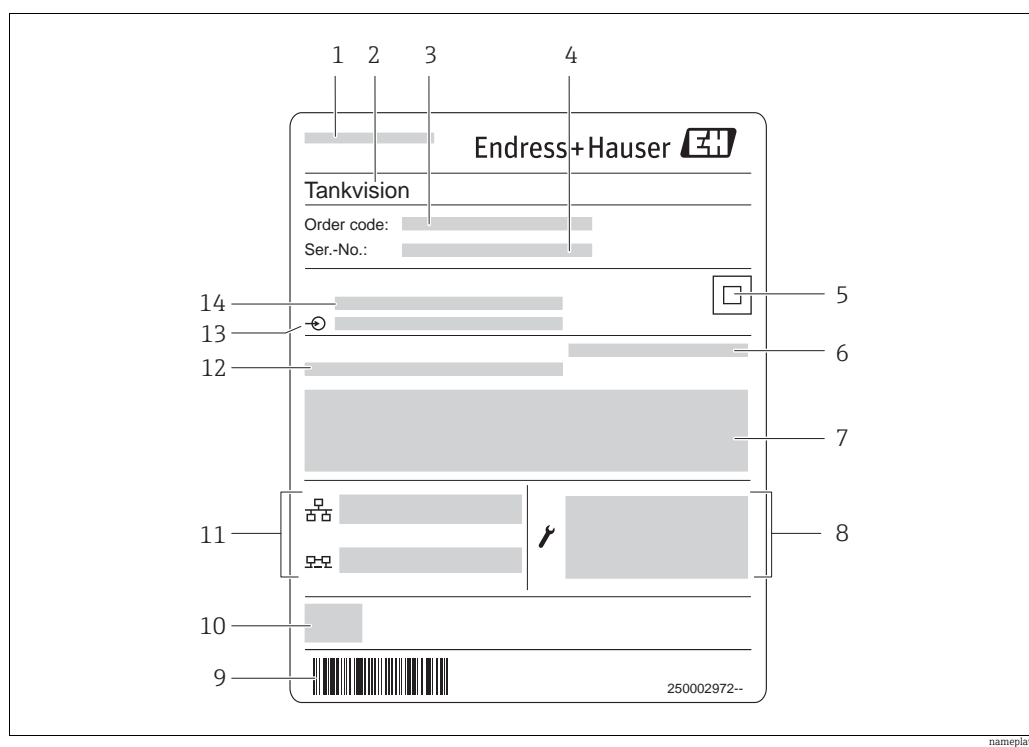

- 1 Address of manufacturer
- 2 Device name
- 3 Order code
- 4 Serial number (Ser. no.)
- 5 Data Matrix Code
- 6 Degree of protection
- 7 Certificate and approval relevant data
- 8 Technical data of the Service LAN port
- 9 Barcode
- 10 CE mark
- 11 MAC address of the System LAN port and Sync LAN port
- 12 Admissible ambient temperature
- 13 Type of fieldbus communication (only for Tank Scanner NXA820)
- 14 Supply voltage

### 3.3 Order code and device version

 To find out the version of your device, enter the order code indicated on the nameplate in the search screen at the following address: [www.products.endress.com/order-ident](http://www.products.endress.com/order-ident)

### 3.4 Registered trademarks

Microsoft®, Windows® and Internet Explorer®  
Registered trademarks of the Microsoft Corporation

Modbus®  
Registered trademark of the Modbus-IDA, Hopkinton, MA, USA

Java®  
Registered trademark of Sun Microsystems, Inc.

Mozilla® Firefox®  
Registered trademark of the Mozilla Foundation



## 4 Installation

### 4.1 Incoming acceptance, transport, storage

#### 4.1.1 Incoming acceptance

Check the packing and contents for any signs of damage.

Check the shipment, make sure nothing is missing and that the scope of supply matches your order.

#### 4.1.2 Delivery content

- Tankvision
- Ferrite for installation on the power supply cable
- Installation Instructions BA00340G/00
- Documentation CD-ROM

#### 4.1.3 Transport, storage

Pack the measuring instrument so that it is protected against impacts for storage and transport. The original packing material provides the optimum protection for this. Permissible storage temperature:  $-40$  to  $+85$  °C ( $-40$  °F to  $+185$  °F).

## 4.2 Mounting

### 4.2.1 Dimensions

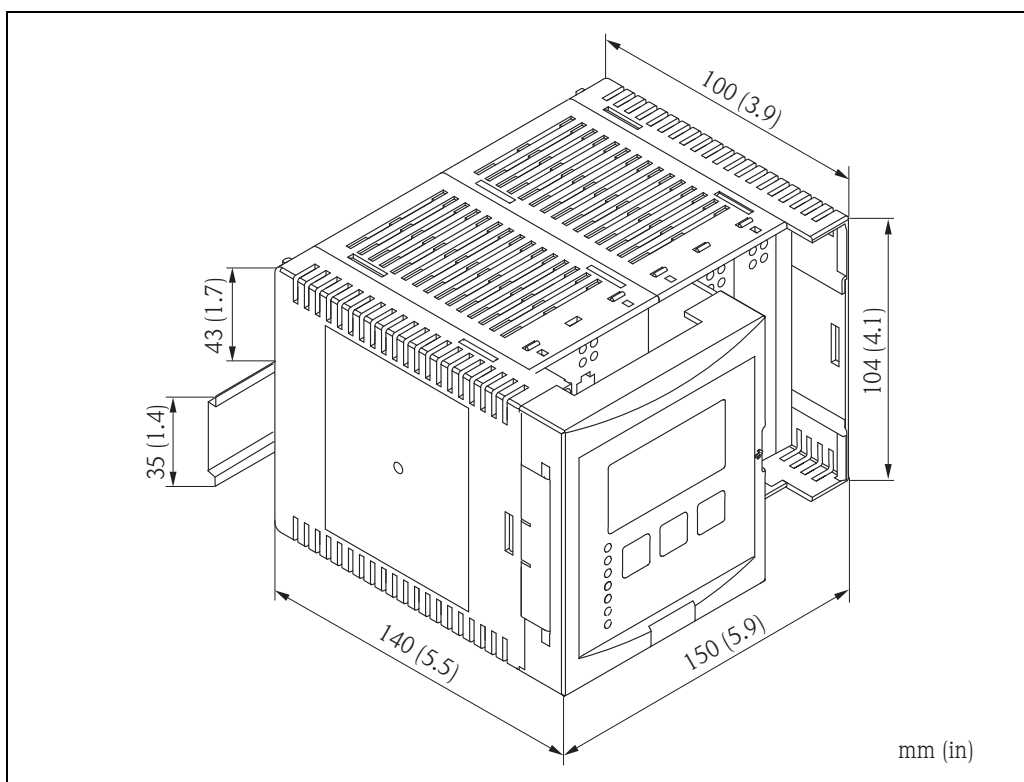

NXA82xxx-06-00-00-yy-002

### 4.2.2 Installation conditions

- The DIN-rail housing must be mounted outside hazardous areas in a cabinet.
- The housing has to be on a DIN rail EN 60715 TH 35x7,5 or TH 37x15.
- Do not install the instrument in the vicinity of high-voltage lines, motor lines, contactors or frequency converters. The installation regulations for high-voltage lines, motor lines, contactors or frequency converters must be observed.
- To ensure easy mounting and opening of the housing, a distance of approx. 1 cm (0.39 in) should be kept between the instruments.

### 4.2.3 Mounting

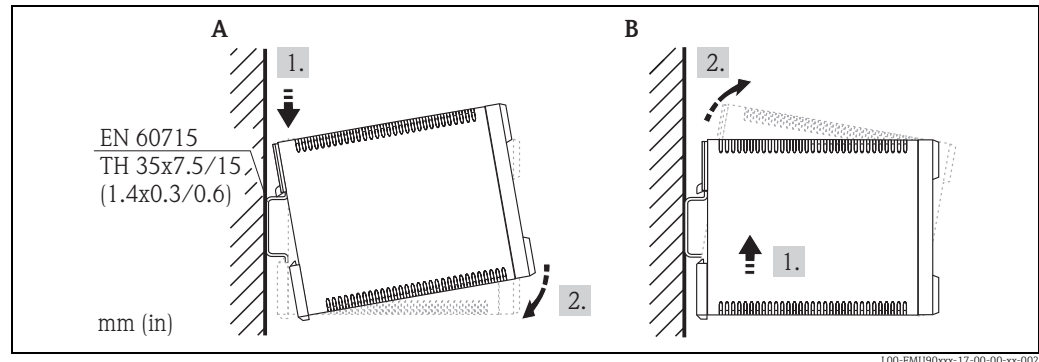

- A** Attaching the instrument to the rail  
**B** Detaching the instrument from the rail

### 4.3 Installation check

After installing the device, carry out the following checks:

- Is the device damaged (visual inspection)?
- Does the device correspond to the measuring point specifications such as ambient temperature etc?
- If available: Are the measuring point number and labelling correct?
- Is the instrument sufficiently protected against rainfall and direct sunlight?
- Is the instrument securely mounted to the DIN rail (visual inspection)?

## 5 Wiring

### 5.1 Wiring examples

#### 5.1.1 Wiring example for NXA820/821/822

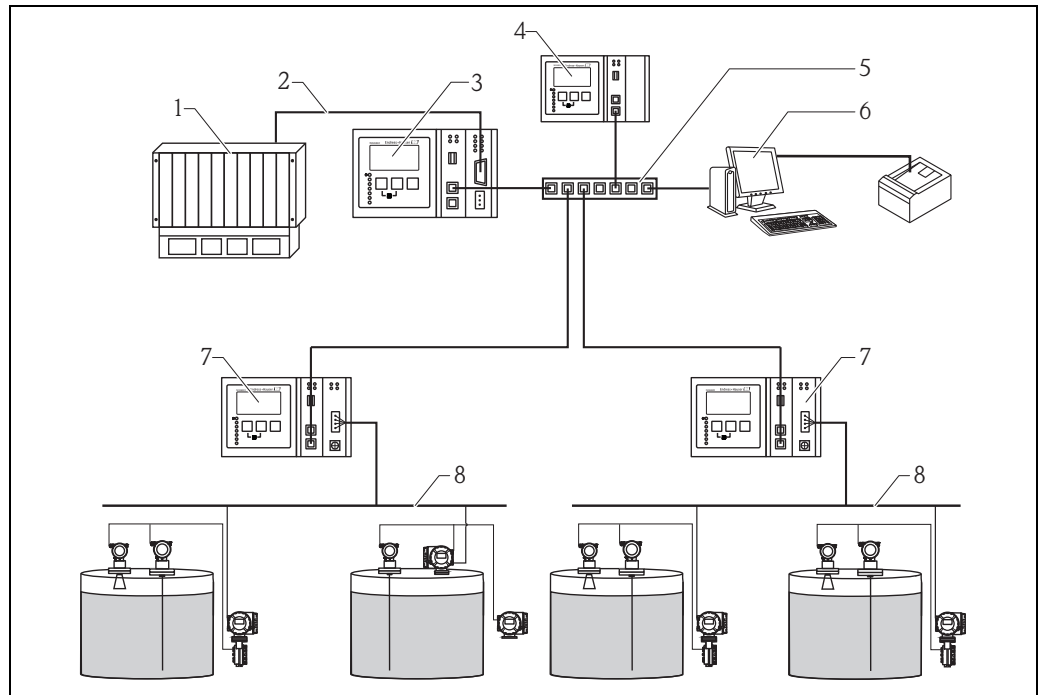

NXA82x\_Wiring\_example

- 1 DCS/PLC (Distributed control system/Programmable logic controlled)
- 2 Modbus
- 3 Host Link NXA822
- 4 Data Concentrator NXA821
- 5 Switch
- 6 Operator with Browser
- 7 Tank Scanner NXA820
- 8 Fieldbus protocol

### 5.1.2 Wiring example for NXA820 "Interface only"

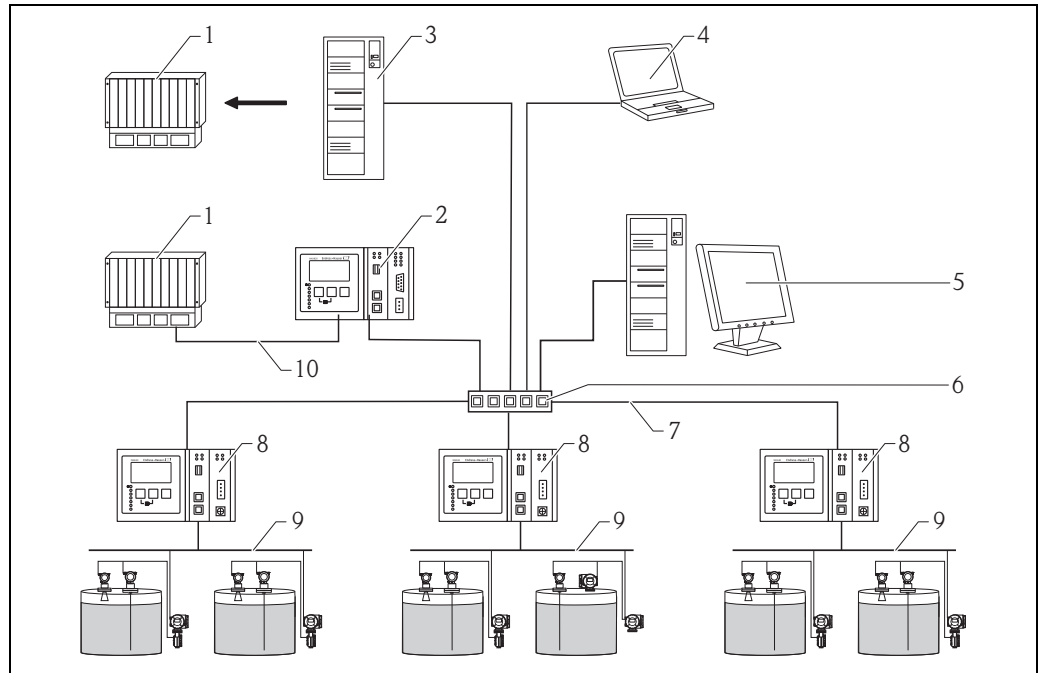

NXA30\_Wiring\_example

- 1 DCS / PLC (Distributed control system / Programmable logic controlled)
- 2 Host Link NXA822
- 3 OPC Server (Open Platform Communications)
- 4 FieldCare
- 5 Tankvision Professional NXA85 Workstation
- 6 Switch
- 7 Ethernet
- 8 Tank Scanner NXA820
- 9 Fieldbus protocol (Modbus, Sakura V1, Whesoe WM550)
- 10 Modbus RTU RS 232/485 or Modbus TCP

### 5.2 Terminal assignment

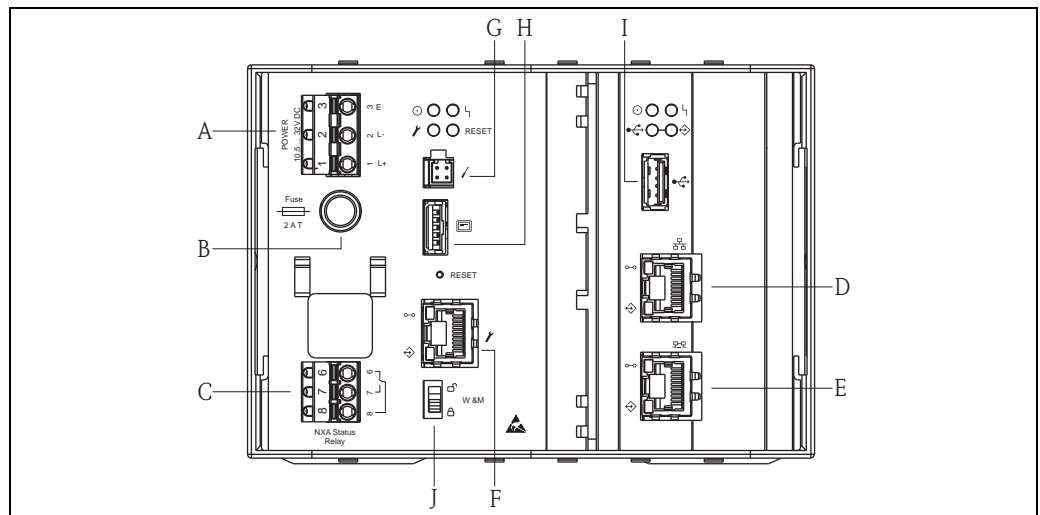

L00-NXA82xxx-04-00-00-yy-020

- A Power supply
- B Fuse
- C Status relay
- D System LAN port
- E Sync Link LAN port
- F Service LAN port
- G Endress+Hauser CDI port
- H Display port
- I USB port
- J Weights & Measures locking switch

### 5.2.1 Power supply

| Terminal Clamp  | Meaning for AC version (90 to 250 VAC) | Meaning for DC version (10.5 to 32 VDC) |
|---|--|---|
| 1   | L                                      | L+                                      |
| 2   | N                                      | L-                                      |
| 3   | Potential equalization                 | Potential equalization                  |
|  | Fuse 400 mA T                          | Fuse 2 A T                              |

 Please check the device designation on the nameplate.

#### Overvoltage Protection

Power supply: 2 x HAW561

Surge arrester HAW651K

- for low voltage users 24/48 V, single pole, requirement class C, basic component with plugged in protection unit, defect display, 18 mm (0.71 in) housing width. Order code: 51003569
- for standard voltage users 115/230 V, single pole, requirement class C, basic component with plugged in protection unit, defect display, 18 mm (0.71 in) housing width. Order code: 51003570

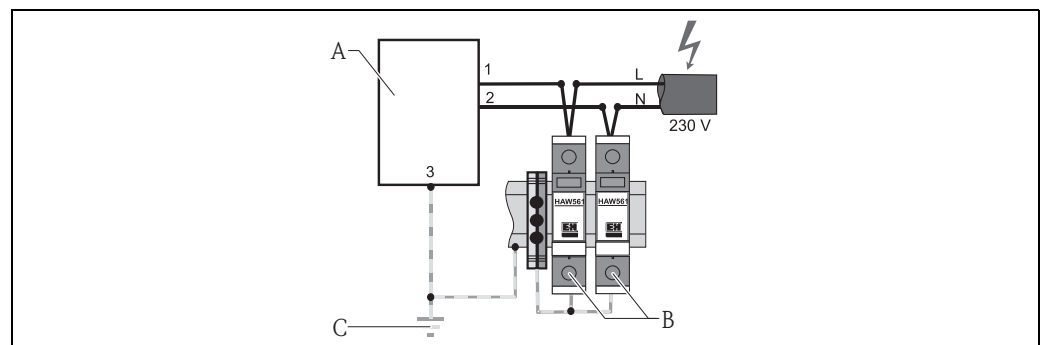

L00-NXA820-04-00-en-001

- A Tankvision  
 B Power supply: 2 x HAW561  
 C Ground connection

#### NOTICE

##### Signal input protection

Risk of overvoltage.

- The signal input with the NXA820 can be protected by a suitable overvoltage protection, additionally to the overvoltage protection which is integrated in the instrument.

### Wiring of DC Variants

To meet the emission class A<sup>1)</sup>, it is mandatory to install the enclosed ferrite as close as possible to the power supply connector of the device. If this is not possible an additional line filter can be installed.

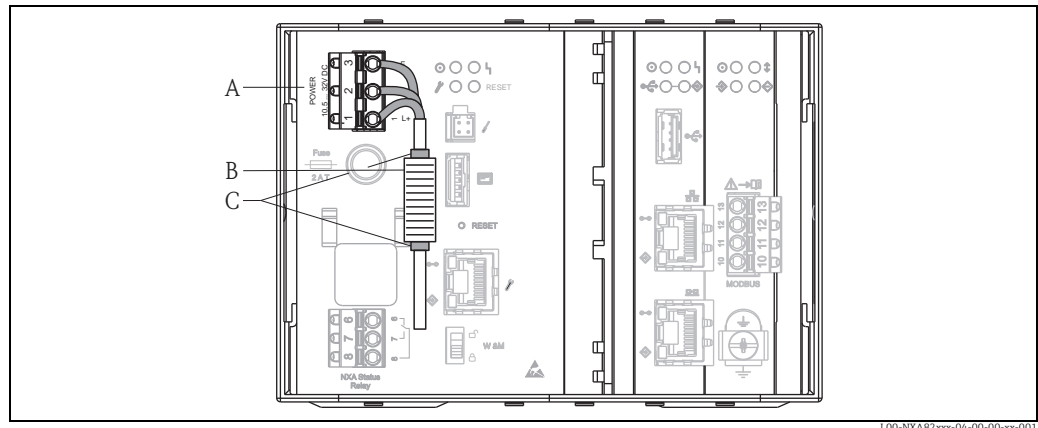

- A Terminal clamp
- B Ferrite
- C Fixation (e.g. cable straps)

The delivered ferrite must be installed as follows:

1. Put over the cable (prior installing the core cable ends).
2. The ferrite must be installed and secured against slippage next to the terminal clamp (e.g. with 2 cable straps).

### 5.2.2 Status Relay

| Terminal Clamp | Meaning                 | Remarks   |
|----------------|-------------------------|---|
| 6              | normally open contact   | <ul style="list-style-type: none"> <li>▪ NXA operating normally: terminals 7 &amp; 8 are interconnected</li> <li>▪ NXA powered off or fault status condition: terminals 6 &amp; 8 are interconnected</li> </ul> |
| 7              | normally closed contact |   |
| 8              | switching contact       |   |





**i** The depicted switching state of the relay refers to the de-energized state.

### 5.2.3 LAN connection

| Socket | Meaning                                       | Remarks   |
|--------|---|---|
|        | <b>System LAN port</b>                        | Connects the instrument to the network.   |
|        | <b>Sync Link LAN port</b><br>(in preparation) | Used for connection to redundant unit. If the primary unit fails, its task is taken over by the redundant unit.   |
|        | <b>Service LAN port</b>                       | Connects the instrument to a computer locally for service purpose. Only this instrument can be configured. The Service LAN port does not allow access to the network. |

1) DIN EN 55011: Industrial, scientific and medical (ISM) radio-frequency equipment - radio disturbance characteristics - limits and methods of measurements

### 5.2.4 Additional elements in the terminal compartment

| Symbol  | Meaning                   | Remarks   |
|---|---------------------------|---|
|  | Endress+Hauser CDI port   | Not used in the Tankvision instrument.  |
|  | Display port              | For the connection of the local display in the housing cover. Is connected on delivery.   |
|  | USB port                  | Reserved for future enhancements.   |
| W&M   | Weights & Measures Switch | <ul style="list-style-type: none"> <li> :W&amp;M parameters are unlocked and can be changed.</li> <li> :W&amp;M parameters are locked and cannot be changed.</li> </ul> |

### 5.3 Terminal assignment Field connection - Tank Scanner NXA820

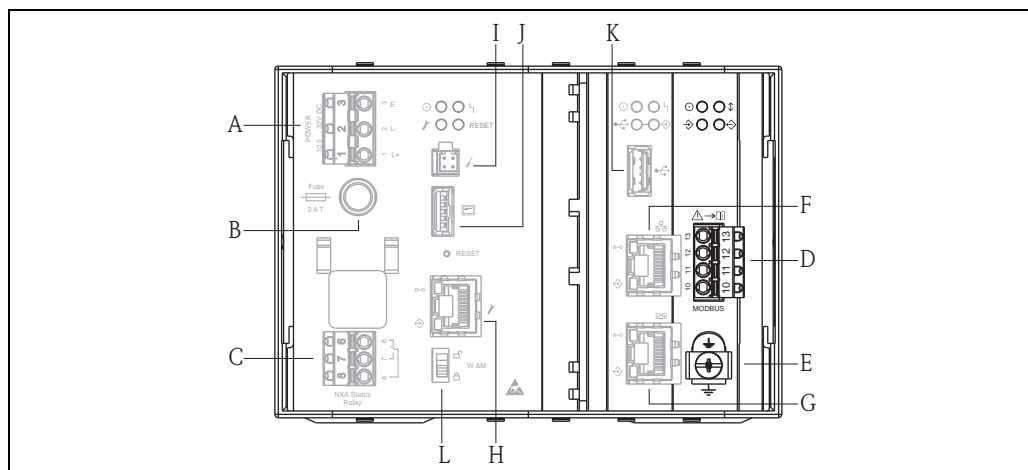

100-NXA82.xxx-04-00-00-xx-004

- A Power supply
- B Fuse
- C Status relay
- D Fieldbus connection
- E Ground
- F System LAN Port
- G Sync Link LAN port
- H Service LAN port
- I Endress+Hauser CDI port
- J Display port
- K USB port
- L Weight & Measures locking switch

#### 5.3.1 Field connection - Tankvision Tank Scanner

**NOTICE**

**Noise and electrical interference**

Prevent noise and electrical interference between the signal and power cables.

- ▶ Take care that the signal and power cables always are separated.

| Terminal Clamp | Modbus RS485 <sup>1)</sup><br>NXA820 - *4***** | Sakura V1 <sup>2)</sup><br>NXA820 - *8***** | Whessoe WM550 <sup>3)</sup><br>NXA820 - *1***** |
|----------------|--|---|---|
| 10             | A Data signal (-)                              | B Data signal (+)                           | - Data signal (-)                               |
| 11             | B Data signal (+)                              | A Data signal (-)                           | + Data signal (+)                               |
| 12             | C Signal Common                                | Not connected                               | Not connected                                   |

| Terminal Clamp  | Modbus RS485 <sup>1)</sup><br>NXA820 - *4***** |                   | Sakura V1 <sup>2)</sup><br>NXA820 - *8***** |                   | Whessoe WM550 <sup>3)</sup><br>NXA820 - *1***** |
|---|--|-------------------|---|-------------------|---|
| 13  | S  | Capacitive Shield | S   | Capacitive shield | Not connected                                   |
|  | Ground   |                   | Ground                                      |                   | Ground  |

1) For details →  16

2) For details →  17

3) For details →  17

### 5.3.2 Additional information on Modbus RS485

#### Connection

As described in the “Modbus over serial line specification and implementation guide V1.02” published by the Modbus-IDA organisation ([www.modbus.org](http://www.modbus.org)) and based upon the EIA/TIA-485-A physical layer specification, Modbus two-wire serial requires the following four electrical connections between each of the devices on the bus.:

| Terminal Clamp | Signal | Purpose         | Remarks  |
|----------------|--------|-----------------|--|
| 10             | A      | Data signal (-) | These signals must be connected using a balanced twisted pair cable. |
| 11             | B      | Data signal (+) |  |
| 12             | C      | Signal Common   | Must interconnect all devices on the bus.                            |
| 13             | Shield | EMC Protection  | Copper braided or combined foil and braided shielding.               |

#### Additional bus settings

- Bus biasing resistors (must be present at one point on the bus) (always enabled inside NXA820)
- Bus termination resistor (must be present at each end of the bus) (software selectable inside NXA820)

#### Cable Specification

|                          |   |
|--------------------------|---|
| Characteristic impedance | 135 to 165 Ω at measuring frequency of 3 to 20 MHz  |
| Cable capacitance        | ≤ 30 pF/m   |
| Core cross-section       | ≥ 0.34 mm <sup>2</sup> (AWG 22) multi-strand cable is preferred   |
| Cable type               | Single twisted pair + third conductor (for common)<br>or<br>Dual twisted pair (common uses second pair with wire joined together) |
| Cable resistance         | ≤ 110 Ω/km  |
| Signal damping           | Max. 9 dB over the entire length of the cable cross-section   |
| Shielding                | Copper braided shielding or combined foil and braided shielding   |



### 5.3.3 Additional information on Sakura V1

#### Connection

| Terminal Clamp  | V1     | Meaning           | Remarks  |
|---|--------|-------------------|--|
| 13  | S      | Capacitive Shield | -  |
| 12  | -      | Not connected     |  |
| 11  | A      | -                 |  |
| 10  | B      | -                 |  |
|  | Ground | -                 | Must be independently connected directly to a primary grounding point using 4 mm <sup>2</sup> cable. |

#### V1 Definition

V1 fieldbus is a voltage mode digital communication using up to  $\pm 30 V_{DC}$ , and requires the following three electrical connections between each of the devices on the bus:

| Signal | Purpose         | Remarks  |
|--------|-----------------|--|
| A      | Data signal (-) | These signals must be connected using a balanced twisted pair cable. |
| B      | Data signal (+) |  |
| Shield | EMC protection  | Copper braided or combined foil and braided shielding                |

#### V1 Cable specification

|                    |  |
|--------------------|--|
| Cable capacitance  | $\leq 50 \text{ nF/m}$   |
| Core cross-section | $\geq 0.9 \text{ mm}^2$ (AWG 17) multi-strand cable is preferred |
| Cable type         | twisted pair   |
| Cable resistance   | $\leq 30 \text{ } \Omega/\text{km}$                              |
| Shielding          | Copper braided shielding or combined foil and braided shielding  |
| Insulation         | $\geq 60 V_{DC}$   |

### 5.3.4 Additional information on Whessoe WM550

The WM550 communication protocol works using a current loop principle.

#### Connection

Please take into consideration that the principle of current loop connection works as follows:

The Tankvision (master) (-) signal point connects to slave 1 (+) signal point. Slave 1 (-) signal point connects to slave 2 (+) signal point until (the last) slave N (-) signal point connects back to the Tankvision (master) (+) signal point closing the current loop.

| Terminal Clamp | Signal | Purpose     | Remarks          |
|----------------|--------|-------------|------------------|
| 10             | -      | Data Signal | Current Loop (-) |
| 11             | +      | Data Signal | Current Loop (+) |

**Cable specification**

Please ensure to follow the following recommendations for field installation of the Tankvision with the WM550 protocol variant

- Cable with twisted and non-shielded pairs
- Cable with at least 0,5 mm<sup>2</sup> (20 AWG) section
- Maximum total cable resistance: 250 Ω
- Cable with low capacitance

|         | Cross section (mm <sup>2</sup> (AWG)) | Resistance (Ω/km) | Capacitance (nF/km) |
|---------|---------------------------------------|-------------------|---------------------|
| Cable 1 | 0,5 (20)                              | 39.2              | 60                  |
| Cable 2 | 0,75 (18)                             | 24.6              | 65                  |
| Cable 3 | 1,3 (16)                              | 14.2              | 75                  |

**5.4 Terminal assignment host/printer connection - Host Link NXA822 / Data Concentrator NXA821**

This chapter is valid for Tankvision Host Link and Tankvision Data Concentrator with Printer Port option.

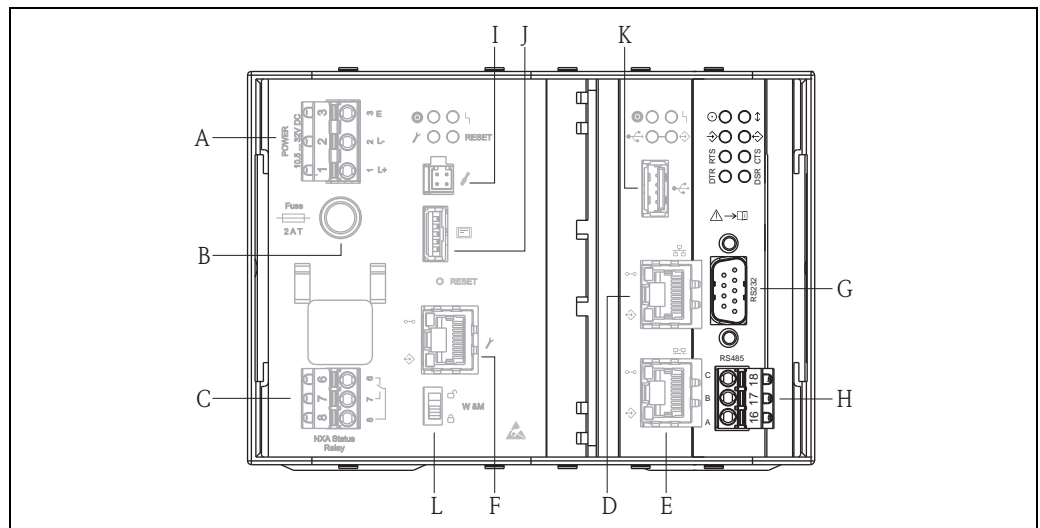

- A Power supply
- B Fuse
- C Status relay
- D System LAN port
- E Sync Link LAN port
- F Service LAN port
- G RS232 Host connection (Host Link or Printer Connection Data Concentrator)
- H RS485 Host connection
- I Endress+Hauser CDI port
- J Display port
- K USB port
- L Weights & Measures locking switch

L00-NXA82xxxx-04-00-00-xx-005

**5.4.1 Host connection: Modbus Serial, EIA/TIA-232 (RS232)**

The NXA822 Host Link is defined as a Data Terminal Equipment (DTE) device, and provides EIA/TIA-232 (RS232) interface through a male DB9 connector whose pin out complies with the EIA/TIA-574 standard:

| Pin | RS232 | Name           | Remarks                      |
|-----|-------|----------------|------------------------------|
| 1   | CD    | Carrier Detect | Signal from connected device |
| 2   | RxD   | Receive Data   | Signal from connected device |

| Pin  | RS232  | Name                | Remarks                      |
|------|--------|---------------------|------------------------------|
| 3    | TxD    | Transmit Data       | Signal to connected device   |
| 4    | DTR    | Data Terminal Ready | Signal to connected device   |
| 5    | G      | Signal Ground       | Common connection            |
| 6    | DSR    | Data Set Ready      | Signal from connected device |
| 7    | RTS    | Request To Send     | Signal to connected device   |
| 8    | CTS    | Clear To Send       | Signal from connected device |
| 9    | RI     | Ring Indicator      | Signal from connected device |
| Case | Shield | Shield              | -                            |

### Definition

EIA/TIA-232 (RS232) is a voltage mode digital communication using up to  $\pm 12 V_{DC}$ , and requires a variety of signals depending on the operating mode (software selectable):

| Signal | Basic RS232 | Fully RS232 with Hardware Handshaking (in preparation) | Remarks  |
|--------|-------------|--|--|
| Shield | Required    | Required   | Copper braided or combined foil and braided shielding          |
| G      | Required    | Required   | -  |
| RxD    | Required    | Required   | -  |
| TxD    | Required    | Required   | -  |
| RTS    | -           | Required   | Null Modem connection, these two pins can be linked together   |
| CTS    | -           | Required   |  |
| DTR    | -           | Required   | Null Modem connection, these three pins can be linked together |
| DSR    | -           | Required   |  |
| CD     | -           | Required   |  |
| RI     | -           | Optional   | Not required   |

### RS-232 Cable Specification

|                    |   |
|--------------------|---|
| Cable capacitance  | $\leq 50 \text{ pF/m}$  |
| Core cross-section | $\geq 0.34 \text{ mm}^2$ (AWG 22) multi-strand cable is preferred |
| Cable type         | Single cable or twisted pair                                      |
| Cable resistance   | $\leq 110 \text{ } \Omega/\text{km}$                              |
| Signal damping     | Max. 9 dB over the entire length of the cable cross-section       |
| Shielding          | Copper braided shielding or combined foil and braided shielding   |

### 5.4.2 Host connection: Modbus Serial, EIA/TIA-485 (RS485)

| Terminal Clamp | EIA/TIA-485 Modbus | Meaning       | Remarks                               |
|----------------|--------------------|---------------|---------------------------------------|
| 18             | C                  | Signal Common | Connector: Phoenix FK 2,5HC/3-St-5,08 |
| 17             | B                  | + signal      |                                       |
| 16             | A                  | - signal      |                                       |

#### Two-Wire Modbus Definition

As described in the “Modbus over serial line specification and implementation guide V1.02” published by the Modbus-IDA organisation ([www.modbus.org](http://www.modbus.org)) and based upon the EIA/TIA-485-A physical layer specification.

Modbus two-wire serial requires the following four electrical connections between each of the devices on the bus:

| Signal | Purpose         | Remarks  |
|--------|-----------------|--|
| A      | Data signal (-) | These signals must be connected using a balanced twisted pair cable. |
| B      | Data signal (+) |  |
| C      | Signal Common   | Must interconnect all devices on the bus.                            |
| Shield | EMC Protection  | Copper braided or combined foil and braided shielding                |

#### Additional EIA/TIA-485 bus settings

- Bus biasing resistors (must be present a one point on the bus) (software selectable inside NXA822)
- Bus termination resistor (must be present a each end of the bus) (software selectable inside NXA822)

#### Cable Specification

|                          |   |
|--------------------------|---|
| Characteristic impedance | 135 to 165 Ω at measuring frequency of 3 to 20 MHz  |
| Cable capacitance        | ≤ 30 pF/m   |
| Core cross-section       | ≥ 0.34 mm <sup>2</sup> (AWG 22) multi-strand cable is preferred   |
| Cable type               | Single twisted pair + third conductor (for common)<br>or<br>Dual twisted pair (common uses second pair with wire joined together) |
| Cable resistance         | ≤ 110 Ω/km  |
| Signal damping           | Max. 9 dB over the entire length of the cable cross-section   |
| Shielding                | Copper braided shielding or combined foil and braided shielding   |

### 5.4.3 Host connection: Modbus TCP/IP (via System LAN port)

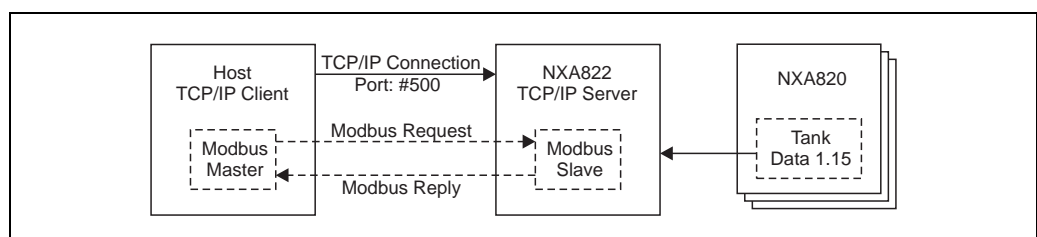

L00-NXA82xxx-04-00-00-yy-024

## 6 Operation station settings

Before configuring and using Tankvision, the following settings are necessary on the operator's computer:

- Deactivate proxy server usage
- Install Java Runtime Environment (JRE)

### 6.1 Deactivate proxy server usage

Before configuring and using Tankvision it is necessary to deactivate the proxy server usage on the user's computer. This can be configured in the web browser.

- i** After deactivating the proxy server usage, it is no longer possible to access the internet. Only the Tankvision pages are available. If you need internet access on the operation station, it is possible to configure the browser in a way that it uses the proxy server for internet pages but not for Tankvision.  
For details please contact your local network administrator.

#### 6.1.1 Microsoft Internet Explorer

1. Open the **Tools** menu.
2. Select **Internet Options**.
3. Select the **Connections** tab.
4. Select the **LAN Settings** button.
5. Deactivate the option **Use a proxy server for your LAN**.
6. Confirm the setting by clicking the **OK** button.

#### 6.1.2 Mozilla Firefox

1. Open the **Tools** menu.
2. Select **Options**.
3. Open the **Advanced** menu.
4. Select the **Network** tab.
5. Click **Settings** to open the **Connection Settings** menu.
6. Activate the option **No proxy**.
7. Confirm the settings by clicking the **OK** button.

## 6.2 Java Runtime Environment (JRE)

### 6.2.1 JRE installation

To operate Tankvision, version 6.0 (update 16) or higher of the Java Runtime Environment (JRE) must be installed on the computer which serves as an operation station.

To install the Java Runtime Environment go to the following internet page:

<http://java.sun.com/products/archive>

There are two installation options:

- Online installation (directly from the internet)
- Offline installation (download of an installation file which can be distributed and executed on the operation stations)

**i** Additional information files (e.g. installation instructions or release notes) are also available from the same internet page.

### 6.2.2 JRE settings

To operate Tankvision, the following settings of the Java Runtime Environment are required:

1. Go to **Start** → **Settings** → **Control Panel** → **Java**.
2. Go to the **Update** tab and deactivate the option **Check for Updates Automatically**.
3. Go to **Settings for temporary internet files**, uncheck **Temp. internet files on Computer** and clear files.

## 7 Tankvision NXA820/821/822 User Interface

Tankvision provides an intuitive user interface allowing the user to quickly navigate through the system. The following sections illustrate various parts of the Tankvision user interface and their usage.

### Home Page (NXA820 with calculations/821/822)



| Pos. | Field                 | Description  |
|------|-----------------------|--|
| 1    | System Header         | Displays the Customer Logo or Graphic.   |
| 2    | Navigation Tree       | Contains header bars corresponding to different functional objects or groups in the system.<br>Refer to "Navigation Tree" (→ 24) for details.  |
| 3    | Main Header           | Displays the following information: <ul style="list-style-type: none"> <li>▪ The site name, tank name, Tankvision tag name or product name - depending on what is displayed in the Main View below the header</li> <li>▪ The system date and time</li> </ul> The main header is displayed with a background color depending on the access rights of the user logged into the system: <ul style="list-style-type: none"> <li>▪ Grey: the user does not have configuration rights and can only view non-real time data.</li> <li>▪ Orange: the user has configuration rights and can view real time data.</li> </ul> |
| 4    | Metadata Header       | Displays the following information: <ul style="list-style-type: none"> <li>▪ The user name and the user type</li> <li>▪ The language options link</li> <li>▪ The help link</li> <li>▪ The logout option</li> </ul>   |
| 5    | Main View             | Displays the screens that the user has selected to configure the settings and view the operational information.<br>Refer to "Main View Section - Colors in Edit Data" (→ 25) for details.  |
| 6    | Alarm and Event Panel | The Alarm and Event Panel displays the real time information about alarms and events.<br>Refer to "Alarm and Event Panel Section" (→ 25) for details.  |

### Home Page (NXA820 Interface only)

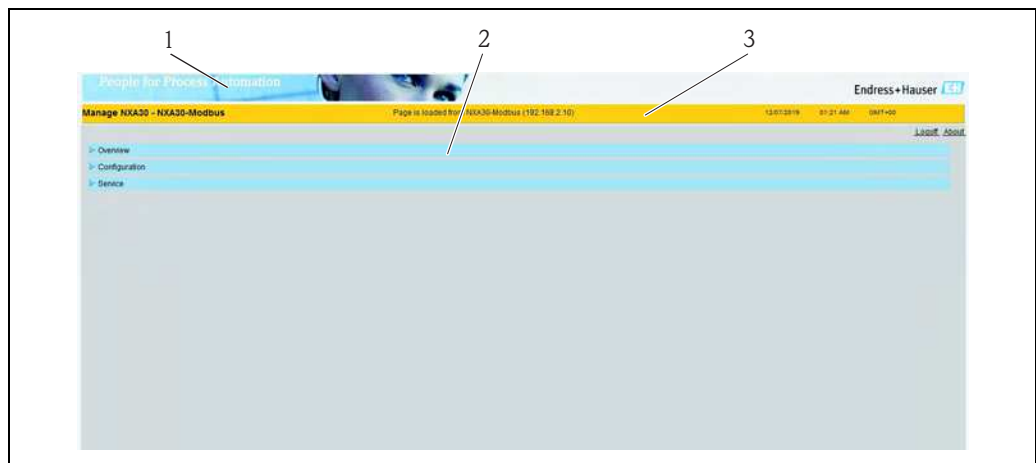

| Pos. | Field         | Description  |
|------|---------------|--|
| 1    | System Header | Displays the Customer Logo or Graphic.   |
| 2    | Main Header   | <p>Displays the following information:</p> <ul style="list-style-type: none"> <li>▪ The product name and Unit tag name</li> <li>▪ The IP address of the Tank Scanner</li> <li>▪ The system date and time</li> </ul> <p>The main header is displayed with a background color depending on the access rights of the user logged into the system:</p> <ul style="list-style-type: none"> <li>▪ Grey: the user does not have configuration rights and can only view non-real time data.</li> <li>▪ Orange: the user has configuration rights and can view real time data.</li> </ul> |
| 3    | Main View     | <p>Displays the following information:</p> <ul style="list-style-type: none"> <li>▪ The "About" link</li> <li>▪ The logout option</li> </ul> <p>Displays the screens that the user has selected to configure the settings and view the operational information.</p> <p>Refer to "Main View Section- Colors in Edit Data" (→ 25) for details.</p>   |

### Navigation Tree (NXA820 with calculations/821/822)

The Navigation Tree is shown on the left side of the screen. Typically, the Navigation Tree allows the user to navigate down to the tanks. The image of the expanded Navigation Tree is as follows:

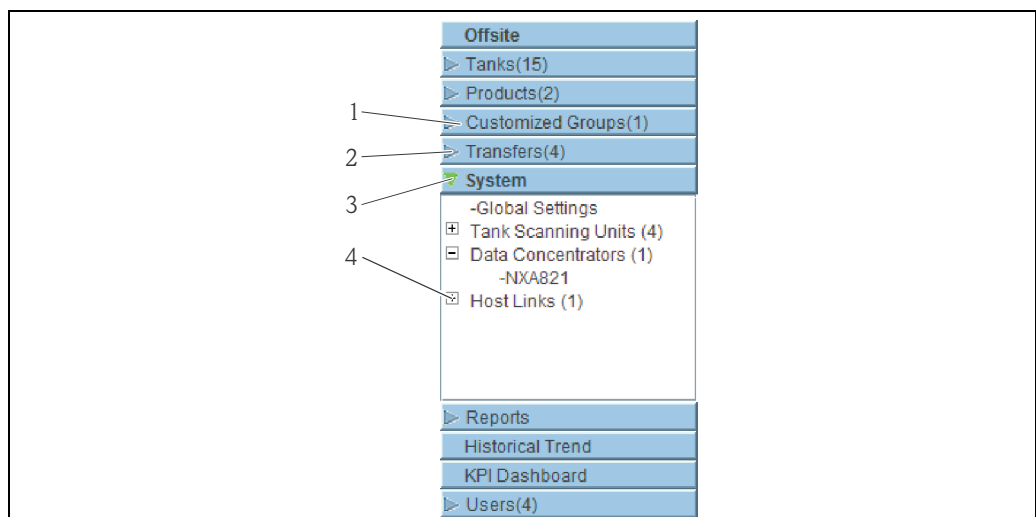



| Pos. | Field           | Description   |
|------|-----------------|---|
| 1    | Header          | The user can click on the text or the arrow of the Header to expand or collapse the branch.<br>The Header name shows a number, which is dynamically appended. The number states the following: <ul style="list-style-type: none"> <li>▪ Tanks: The number of tanks in the NXA820</li> <li>▪ Products: The number of products defined in the system</li> <li>▪ Alarm Groups: The number of alarm groups defined in the system</li> <li>▪ Customized Groups: The number of tank groups defined in the system</li> <li>▪ Transfers: The number of product transfer stages (Waiting, In Progress, Finished, and Aborted) defined in the system</li> <li>▪ Users: The number of users defined in the system</li> </ul> The text will appear in bold and black when the header is in the expanded form. |
| 2    | Collapsed Arrow | This type of arrow is displayed when the Header is in the collapsed position. Click on the collapsed arrow to expand the Header.  |
| 3    | Expanded Arrow  | This type of arrow is displayed when the Header is in the expanded position. Click on the expanded arrow to collapse the Header.  |
| 4    | Node            | The user can click on the Node to view the operational information on the Main View section. If a Node is selected, it will appear in red color.<br>The number of tanks in the group is appended to the Node name.  |

### Main View Section - Colors in the Edit Data Area

The system displays different colors in the Edit Data area, based on the access rights of the user:

1. If the user has access rights, then the edit data area has a light grey and light yellow background on alternate rows. The **Submit** button to save the settings is enabled.

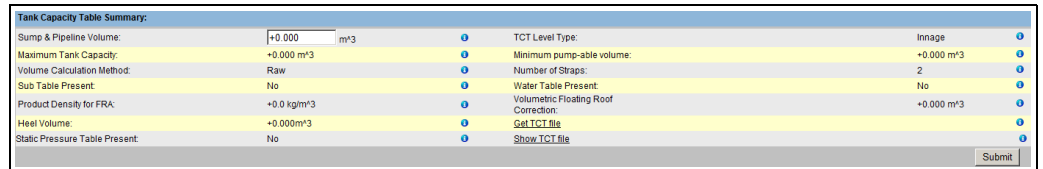

NXA82x\_Tank-Capacity-Table-Summary

2. If the user does not have access rights, then the edit data area has a light grey and dark grey background on alternate rows. The **Submit** button to save the settings is disabled.



NXA82x\_Tank-Capacity-Table-Summary\_Inactive

### Alarm and Event Panel (NXA820 with calculations/821/822)

The Alarm and Event Panel displays the alarm and event information, which is dynamically generated by the system.

| Alarm & Event |        |        |     |         |               |              |          |       |             |          |        |
|---------------|--------|--------|-----|---------|---------------|--------------|----------|-------|-------------|----------|--------|
| Date          | Event  | Status | Ack | Element | Sub Type      | Object       | Value    | Email | UserID      | Event ID | Option |
| 04/18/2006... | System | N/A    | N/A | N/A     | Bad Config... | /dev/shme... | N/A,Fail | N/A   | X86_KAUS... | 278      |        |
| 04/18/2006... | System | N/A    | N/A | N/A     | Bad Config... | /dev/shme... | N/A,Fail | N/A   | X86_KAUS... | 277      |        |
| 04/18/2006... | System | N/A    | N/A | N/A     | Bad Config... | /dev/shme... | N/A,Fail | N/A   | X86_KAUS... | 276      |        |
| 04/18/2006... | System | N/A    | N/A | N/A     | Bad Config... | /dev/shme... | N/A,Fail | N/A   | X86_KAUS... | 275      |        |
| 04/18/2006... | System | N/A    | N/A | N/A     | Bad Config... | /dev/shme... | N/A,Fail | N/A   | X86_KAUS... | 274      |        |

---

| Tab            | Description  |
|----------------|--|
| Alarm          | Displays details of the alarms generated by the system.            |
| Events         | Displays details of the events generated by the system.            |
| Alarm & Events | Displays details of the alarms and events generated by the system. |

## 8 Tankvision NXA820/821/822 Configuration

**i** This chapter refers to NXA820 with calculations. For Tank Scanner with "Interface only" option → 41.

### 8.1 Logging into the Tankvision NXA820/821/822 system

To integrate a Tankvision unit (i.e. a Tank Scanner NXA820, Data Concentrator NXA821 or Host Link NXA822) into the network, proceed as follows:

1. Connect a laptop to the service port of the Tankvision unit. Make sure that the laptop is configured to get a dynamic IP addresses from a DHCP server.

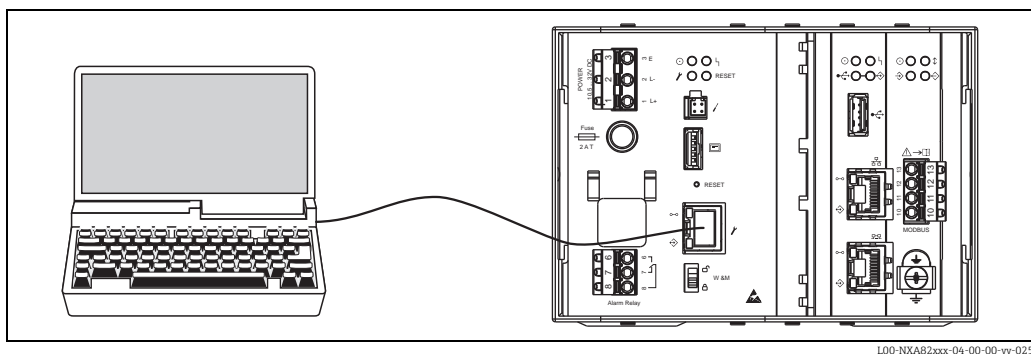

2. Open the internet browser and enter the following URL: <http://192.168.1.1>  
The Tankvision login screen appears. The user ID (= User Login Name) and password are defined by the system administrator when adding a user to the system (see BA00339G/00/EN).
3. Login as Supervisor.



| Field    | Description  |
|----------|--|
| User ID  | Enter the appropriate user login name .<br>The user login name is alphanumeric and case sensitive.                         |
| Password | Enter the appropriate password.<br>The user password is alphanumeric and case sensitive. It consists of 3 to 8 characters. |

| Field   | Description   |
|---------|---|
| Options | Click the <b>Options</b> button to display the connection options. Available options are <b>Local</b> and <b>Remote</b> . By default, the system selects the <b>Local</b> option. This allows the user to log into the Tankvision system within the network (LAN). The <b>Remote</b> option allows the user to log into the Tankvision system outside the network (Internet). |

- Enter **Super** into **User ID**.
- Enter **Super** into **Password**.
- Click the **Login** button.

Tankvision displays the Home Page.

## 8.2 Common settings - Tankvision NXA820/821/822 system

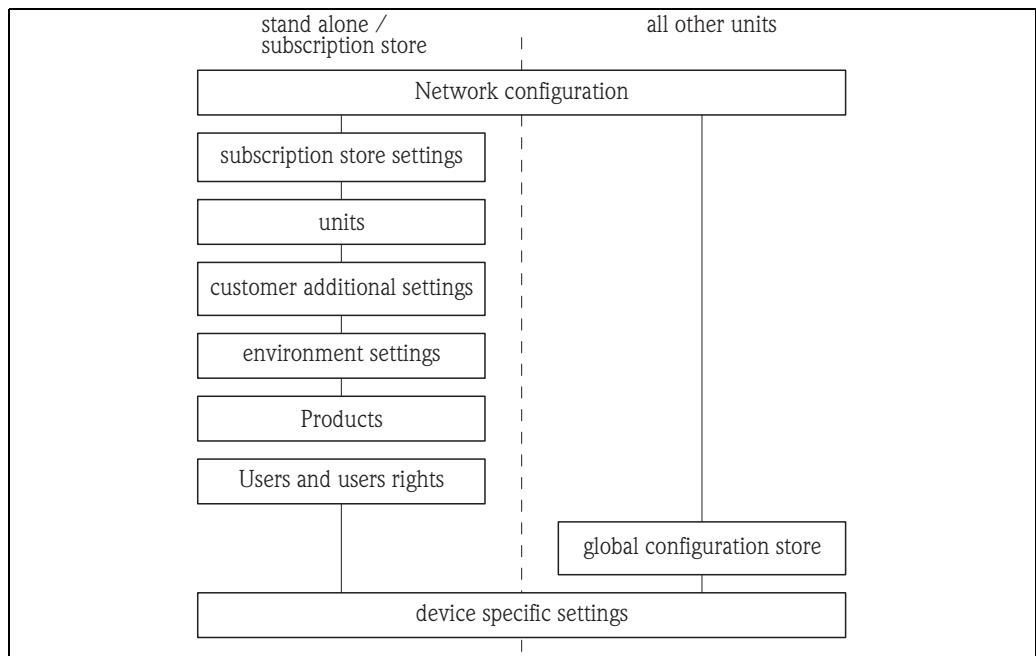

### 8.2.1 Network settings

You are logged in as "Supervisor".

1. In the navigation tree, click the **System** Header. It expands as follows:



NXA82x\_Menu\_System

2. Click **Global Settings**. Tankvision displays the screen as follows:



NXA82x\_Global-Settings-Screen

3. Click **Network Settings**. Tankvision displays the screen as follows:

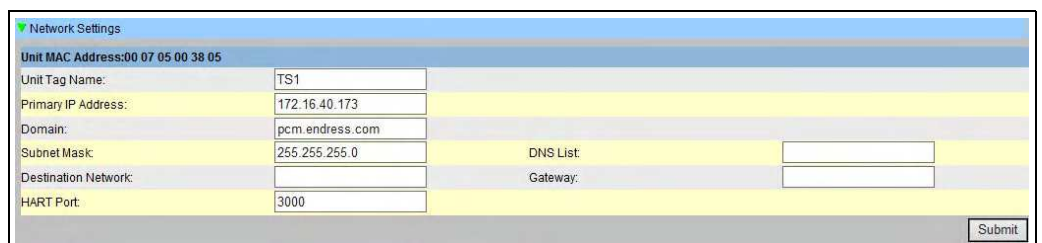

NXA82x\_Network-Settings

4. Enter the appropriate information in the relevant fields.

- Parameters marked by an asterisk are mandatory.
- The required values of the parameters depend on your local network configuration. For more information please contact your local network administrator.

- Detailed information on the individual fields can be found in BA00339G, "Tankvision NXA820, NXA821, NXA822 - Description of Instrument Functions".
- 5. Click the **Submit** button to proceed. The system displays a confirmation box as follows:

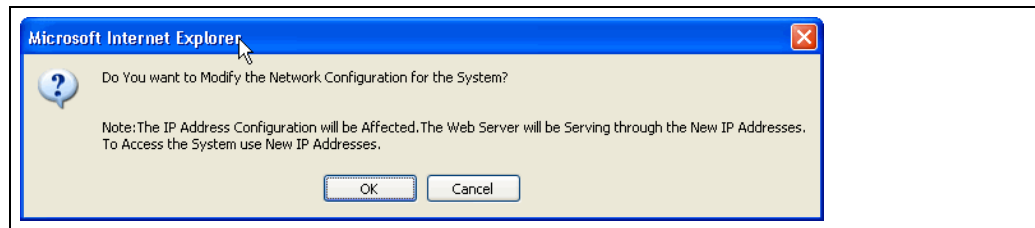

- 6. Click the **OK** button to proceed, or click the **Cancel** button to exit.
- 7. After saving the settings, Tankvision displays a confirmation message.
- 8. Disconnect the laptop and connect the Tankvision unit to the network using the System LAN port. The Tankvision unit can now be operated from a computer within the LAN.

## 8.2.2 Subscription Store definition

In a typical Tankvision system, most configuration settings are common for all Tankvision units within the network. Therefore, the time required for the configuration of the system can be minimized by defining one of the units to be a Subscription Store. The configuration settings are only performed on this Subscription Store. These settings are then distributed to the other units within the network.

For each Tankvision unit (i.e. Tank Scanner NXA820, Data Concentrator NXA821 or Host Link NXA822) within the network it is necessary to define if it is a Subscription Store or if it receives its configuration from a Subscription Store.

To do so, proceed as follows:

- 1. Login to the Tankvision unit as "Supervisor" and navigate to the **Global Settings** screen (→ 28).  
Click on **Customer Settings**.
- 2. Click on **Define Configuration Store Details**. Tankvision displays the screen as follows:

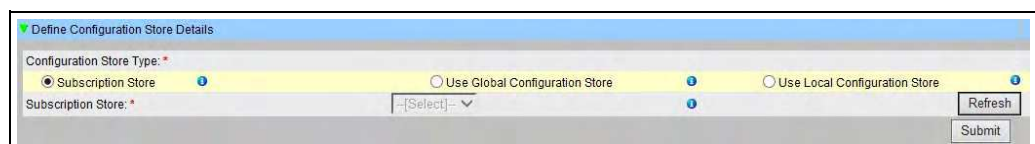

NXA82x\_Define-Configuration-Store-Details

- 3. **for the Subscription Store:**
  - In **Configuration Store Type** select the option **Subscription Store** (Default)
  - for the other units:**
    - In **Configuration Store Type** select the option **Use Global Configuration Store**
    - In **Subscription Store** select the Subscription Store to which this unit is to be linked
- 4. Click the **Submit** button to proceed, or click the **Refresh** button to reset the screen.
- 5. After saving the settings, Tankvision displays a confirmation message.

With the (recommended) use of global configuration store the following information is transferred to the subscription units:

- Customer settings like site information (without customer specific logo), unit, email server and day and time settings (configurations of languages and printer agent must be done for every single device)
- Environment settings
- Products
- Users incl. user access rights

Global settings could be changed later on, also after assigning other units. Its highly recommended to use a NXA820 as subscription store.

### 8.2.3 Further common steps (stand alone or subscription store)

Login to the Tank Scanner NXA820 as "Supervisor" and perform the following configurations (for details refer to BA00339G/00/EN "Tankvision NXA820, NXA821, NXA822 - Description of Instrument Functions"):

#### Customer Settings and Environment Settings

1. In the navigation tree, click the **System** header.
2. Click **Global Settings** (below the **System** header).
3. In the main screen click the **Customer Settings** header and configure the parameters. For a description of the parameters refer to BA00339G/00/EN. At least units, site information, day and time and Email server (if required).
4. In the main screen, click the **Environment Settings** header and configure the parameters. For a description of the parameters refer to BA00339G/00/EN.

#### Product Configuration

1. In the navigation tree, click the **Products** header.
2. Click the **Add** button to add a new product.
3. Click the individual headers of the **Product** menu (**General Details, Volume Correction Factor, ...**) and define the product properties. For a description of the parameters refer to BA00339G/00/EN.

#### Users and user access rights

1. In the navigation tree, click the **Users** header.
2. Click on **Group rights** tab and define the rights of the different users.
3. Click on **User view** and create the required users.

### 8.2.4 Tank Scanner NXA820 specific settings

Login to the Tank Scanner NXA820 as "Supervisor" and perform the following configurations (for details refer to BA00339G "Tankvision NXA820, NXA821, NXA822 - Description of Instrument Functions"):

#### Field Scan Configuration

1. In the navigation tree, click the **System** header.
2. Click **Global Settings** (below the **System** header).
3. In the main screen, click the **Field Scan** header.
4. Click the individual headers of the **Field Scan** menu and configure the parameters<sup>2)</sup>. For a description of the parameters refer to

2) The parameters can only be edited if the field scan is not currently active. If necessary, go to the 'Start/Stop Field Scan' tab and stop the field scan.

- BA00339G, Chapter 11.5 (Modbus)
- BA00339G, Chapter 11.6 (V1)
- BA00339G, Chapter 11.7 (WM550)

### Tank Configuration

1. In the navigation tree, click the **Tanks** header.
2. In the main screen, select the tank you are going to configure and click the **Modify** button.
3. Click the individual headers of the tanks menu (**General Details, Capacity Details, ...**) and configure the parameters. For a description of the parameters refer to BA00339G/00/EN.

### Product-tank assignment

1. In the navigation tree, click the **Tanks** header.
  2. In the list below the **Tanks** header select a tank.
  3. In the main screen click the **Assignment Product** tab (if necessary use the << or >> button to find the **Assign Product** tab).
  4. Select the product from the drop-down list.
  5. Click **Submit** to save the settings.
-  For details about tank-product assignment refer to BA00339G/00/EN.

### Additional Settings

Depending on your requirements, you can perform numerous further settings. For details refer to BA00339G.

### Start Field Scan

1. In the navigation tree, click the **System** header.
2. Click **Global Settings** (below the **System** header).
3. In the main screen, click the **Field Scan** header.
4. Click the **Start/Stop Field Scan** tab and then click on **Start**. Field Scanning is now active.

## 8.2.5 Data Concentrator NXA821 specific settings

### Associate Tank Scanner

Assign the Tank Scanner NXA820 to the Data Concentrator NXA821:

1. Login to the Data Concentrator NXA821 as "Supervisor".
2. In the navigation tree, click the **System** header.
3. Click **Global Settings** (below the **System** header).
4. In the main screen, click the header **Tank Scanner Unit And Tank Assignment**.
5. Select all Tank Scanner units you want to assign to the Data Concentrator from the **Available Units** list and move them to the **Selected Units** list using the arrow buttons. All units in the "Selected Units" list will be assigned to the Data Concentrator.
6. Click the **Submit** button to save the settings.

### Additional Settings (like groups)

Depending on your requirements, you can perform numerous further settings. For details refer to BA00339G/00/EN.



- i** For details refer to BA00339G/00/EN, "Tankvision NXA820, NXA821, NXA822 - Description of Instrument Functions"

### 8.2.6 Host Link NXA822 specific settings

The Host Link NXA822 provides an interface for a host system to access inventory data from the NXA820 unit.

To configure the Host Link settings, proceed as follows:

1. Login to the Host Link NXA822 as "Supervisor".
2. In the navigation tree, click the **System** header.
3. Click **Global Settings** (below the **System** header).
4. In the main screen, click the **Field Scan** header.  
It contains the following subheaders which are used to configure the Host Link settings and to start the Host Link:

- Host Link Configuration
- Modbus TCP Configuration (if the Modbus TCP protocol has been selected).
- Modbus Serial (if the Modbus Serial protocol has been selected).
- Entis+ (if the Entis+ serial protocol has been selected)
- Start/Stop Host Link

For details please refer to BA00339G/00/EN, "Tankvision NXA820, NXA821, NXA822 - Description of Instrument Functions"

### 8.2.7 Configuration of W+M systems

#### Description of the sealing process

*Locking mechanisms in Tankvision:*

Connected PCs are registered in the system by assigning the MAC address. Once the system has been locked, only these PCs are accepted and can display calibrated data.

When the W+M switch is flipped, a checksum is calculated and set.

This calculation is repeated every 8 hours. If this checksum deviates from that at the time of sealing, changes have been made to the system. It is no longer possible to modify W+M parameters, such as tank tables, units and print templates, once the W+M switch has been flipped.

*Recommended procedure:*

It is recommended to start calibrating the tank gauging system from the field devices via possible protocol converters and finish the process with the Tankvision inventory management system. When calibrating the Tankvision Tank Scanner or Data Concentrator, it is recommended to start with the unit used as the Global Configuration Store since the engineering units are configured centrally here. These units would then not have to be checked separately in the boxes assigned (→  33).

#### Initial calibration and system modifications

*Units*

The units do not have to be configured if **Use Global Configuration Store** is selected. The units can be checked under **System** → **Tank Scanner Unit** → **Customer Settings** → **Units**. This view allows the user to choose between the unit schemes.

Selecting the Unit

The exact settings of the unit scheme selected can be checked under **Advanced**.

NXA82x\_Units

Checking the Units

- An apostrophe may not be chosen as the thousand separator for W&M applications.
- If the Tankvision device retrieves the basic settings from another Tankvision device (Global Configuration Store), the units of this Tankvision device do not have to be checked. The name of the box (Subscription Store) that provides the basic settings can be found under **System** → **Global Settings** → **Customer Settings** → **Define Configuration Store Details**.

NXA82x\_Define-Configuration-Store-Details

Configuration Store Details

*Field device assignment*

The field device assignment must be checked under **System** → **Tank Scanner Unit** → **Field Scan** → **Manage Field Scan Configuration-Modbus EIA485**.

The following parameters have to be checked for Modbus EIA485:

- Baud rate
- Parity
- Gauge slave address: assignment to the tank ID/tank name
- Gauge type: assignment to the tank ID/tank name
- Modbus register map: assignment to the field device type (gauge type)

**▼ Manage Field Scan Configuration - Modbus EIA485**

Baud Rate:  9600

Parity:  No Parity

EIA485 Termination Resistor:

| Tank ID | Tank Name | Enabled                  | Gauge Slave Address | Gauge type     | Modbus Register Map |
|---------|-----------|--------------------------|---------------------|----------------|---------------------|
| 1       | Tank-1    | <input type="checkbox"/> | 0                   | ProServo NMS53 | servomm.xml         |
| 2       | Tank-2    | <input type="checkbox"/> | 0                   | ProServo NMS53 | servomm.xml         |
| 3       | Tank-3    | <input type="checkbox"/> | 0                   | ProServo NMS53 | servomm.xml         |
| 4       | Tank-4    | <input type="checkbox"/> | 0                   | ProServo NMS53 | servomm.xml         |
| 5       | Tank-5    | <input type="checkbox"/> | 0                   | ProServo NMS53 | servomm.xml         |
| 6       | Tank-6    | <input type="checkbox"/> | 0                   | ProServo NMS53 | servomm.xml         |
| 7       | Tank-7    | <input type="checkbox"/> | 0                   | ProServo NMS53 | servomm.xml         |
| 8       | Tank-8    | <input type="checkbox"/> | 0                   | ProServo NMS53 | servomm.xml         |
| 9       | Tank-9    | <input type="checkbox"/> | 0                   | ProServo NMS53 | servomm.xml         |
| 10      | Tank-10   | <input type="checkbox"/> | 0                   | ProServo NMS53 | servomm.xml         |
| 11      | Tank-11   | <input type="checkbox"/> | 0                   | ProServo NMS53 | servomm.xml         |
| 12      | Tank-12   | <input type="checkbox"/> | 0                   | ProServo NMS53 | servomm.xml         |
| 13      | Tank-13   | <input type="checkbox"/> | 0                   | ProServo NMS53 | servomm.xml         |
| 14      | Tank-14   | <input type="checkbox"/> | 0                   | ProServo NMS53 | servomm.xml         |
| 15      | Tank-15   | <input type="checkbox"/> | 0                   | ProServo NMS53 | servomm.xml         |

**Ambient Temperature Configuration**

| Enabled                  | Gauge Slave Address | Gauge type     | Modbus Register Map |
|--------------------------|---------------------|----------------|---------------------|
| <input type="checkbox"/> | 0                   | ProServo NMS53 | servomm.xml         |

*Field Scan Configuration - Modbus*

The following parameters have to be checked for the V1 protocol:

- Gauge slave address (DEC) assignment to the tank ID/tank name
- Gauge type assignment to the tank ID/tank name
- V1 map file assignment to the gauge type

**▼ Manage Field Scan Configuration - V1**

**Physical Interface Configuration**

Pulse Period:  us (303 to 703 microseconds) ⓘ

Pulse Amplitude:  Volts ⓘ

| Tank ID | Tank Name | Enabled                             | Gauge Slave Address (DEC) | Gauge type     | V1 Map File        |
|---------|-----------|-------------------------------------|---------------------------|----------------|--------------------|
| 1       | T-101     | <input checked="" type="checkbox"/> | 1                         | ProServo NMS53 | NewV1LevelTemp.xml |
| 2       | T-102     | <input checked="" type="checkbox"/> | 2                         | ProServo NMS53 | NewV1LevelTemp.xml |
| 3       | T-103     | <input type="checkbox"/>            | 0                         | ProServo NMS53 | NewV1LevelTemp.xml |
| 4       | T-104     | <input type="checkbox"/>            | 0                         | ProServo NMS53 | NewV1LevelTemp.xml |
| 5       | T-205     | <input type="checkbox"/>            | 0                         | ProServo NMS53 | NewV1LevelTemp.xml |
| 6       | T-106     | <input type="checkbox"/>            | 0                         | ProServo NMS53 | NewV1LevelTemp.xml |
| 7       | T-107     | <input type="checkbox"/>            | 0                         | ProServo NMS53 | NewV1LevelTemp.xml |
| 8       | T-108     | <input type="checkbox"/>            | 0                         | ProServo NMS53 | NewV1LevelTemp.xml |
| 9       | T-209     | <input type="checkbox"/>            | 0                         | ProServo NMS53 | NewV1LevelTemp.xml |
| 10      | T-210     | <input type="checkbox"/>            | 0                         | ProServo NMS53 | NewV1LevelTemp.xml |

**Ambient Temperature Configuration**

| Enabled                  | Gauge Slave Address            | Gauge type     | V1 Map File        |
|--------------------------|--------------------------------|----------------|--------------------|
| <input type="checkbox"/> | <input type="text" value="0"/> | ProServo NMS53 | NewV1LevelTemp.xml |

Field Scan Configuration - V1 Protocol

The following parameters have to be checked for the WM550 protocol:

- Baud rate
- Loop current
- Gauge slave address assignment to the tank ID / tank name
- Gauge type assignment to the tank ID / tank name
- WM550 map file assignment to the field device type (gauge type)

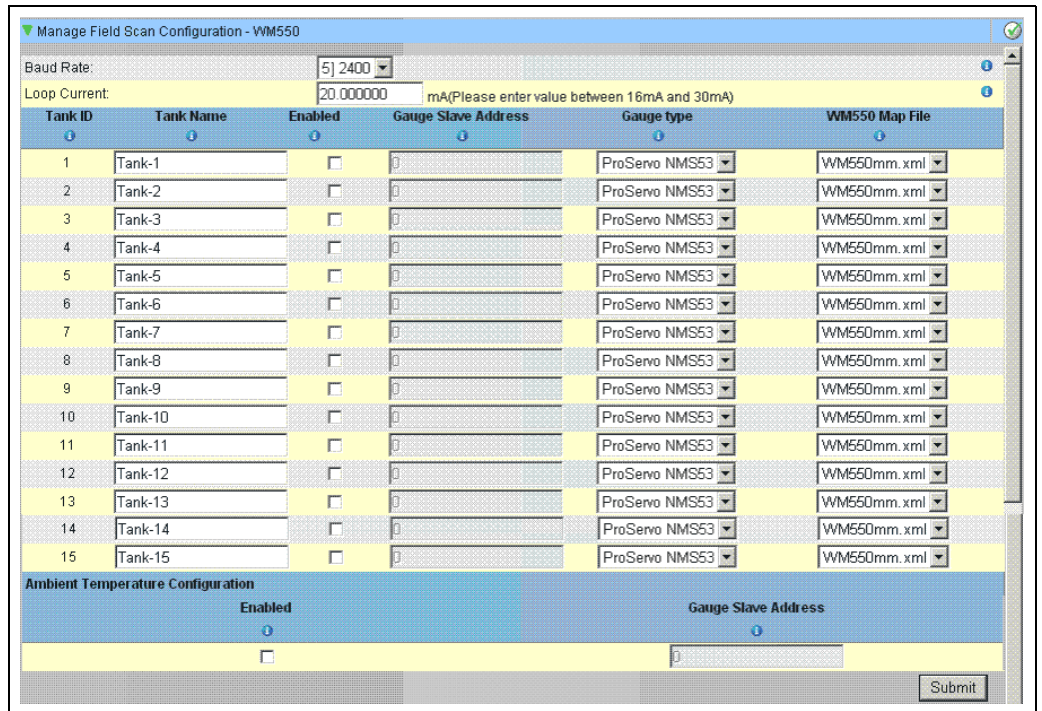

Field Scan Configuration - WM550 Protocol

Tank table

The tank capacity details have to be loaded to check the tank table (**Tanks** → Select the tank under **Select** - select and confirm with **Modify** (see Fig. "Tank Selection") → Select **Capacity Details** (see Fig. "Tank Capacity Table Summary"))).

| Select                           | Tank Name | Location   | Tank Shape                             | Product    |
|----------------------------------|-----------|------------|--|------------|
| <input checked="" type="radio"/> | Tank-1    | Terminal-1 | Tank with Fixed Roof, without Stilling | No Product |
| <input type="radio"/>            | Tank-2    | Terminal-1 | Tank with Fixed Roof, without Stilling | No Product |
| <input type="radio"/>            | Tank-3    | Terminal-1 | Tank with Fixed Roof, without Stilling | No Product |
| <input type="radio"/>            | Tank-4    | Terminal-1 | Tank with Fixed Roof, without Stilling | No Product |
| <input type="radio"/>            | Tank-5    | Terminal-1 | Tank with Fixed Roof, without Stilling | No Product |
| <input type="radio"/>            | Tank-6    | Terminal-1 | Tank with Fixed Roof, without Stilling | No Product |
| <input type="radio"/>            | Tank-7    | Terminal-1 | Tank with Fixed Roof, without Stilling | No Product |
| <input type="radio"/>            | Tank-8    | Terminal-1 | Tank with Fixed Roof, without Stilling | No Product |
| <input type="radio"/>            | Tank-9    | Terminal-1 | Tank with Fixed Roof, without Stilling | No Product |
| <input type="radio"/>            | Tank-10   | Terminal-1 | Tank with Fixed Roof, without Stilling | No Product |

Tank Selection

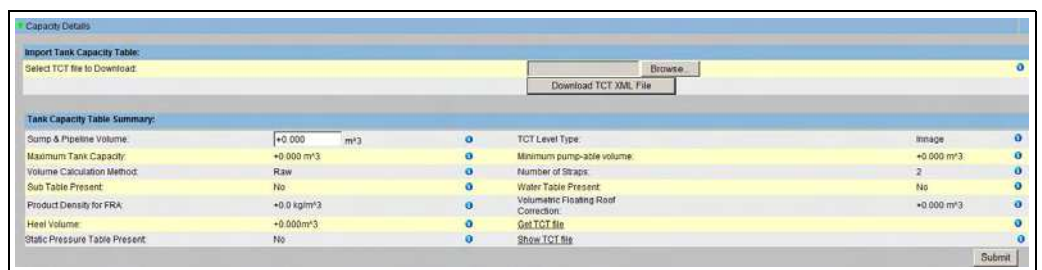

Tank Capacity Table Summary

Steps for checking the tank table:

- Check that the information in the Tank Capacity Table Summary is correct for the selected tank.
- Check whether the TCT is suitable for the relevant tank.

Clicking **Show TCT file** opens a browser window that shows the TCT in a tabular form (with the units in the configured format). Print by clicking **Print TCT**. To store the TCT file on a PC, click the **Get TCT file** link. The system will perform an export of the TCT in XML form as a compressed file (.gz). All units in the file are SI units (independent from the configured format). The data in the TCT XML file are displayed in the "Table in XML Format" graphic.

```

- <Tankvision CRC="12345">
- <TCT VSP_TABLE="Y" WATER_TCT="Y" Sub_TCT="N" TCT_CalDate="3/28/2011" TCT_Date="3/28/2011">
  <Level_Type>Innage</Level_Type>
  - <Units>
    <Level>mm</Level>
    <Volume>m3</Volume>
    <P_Density_FRA_Unit>kg/m3</P_Density_FRA_Unit>
  </Units>
  - <FRA_TCT>
    <P_Density_FRA>1500</P_Density_FRA>
    <V_FRC>1</V_FRC>
  </FRA_TCT>
  <Heel_Volume>50</Heel_Volume>
  
```

Table in XML Format

*PC assignment*

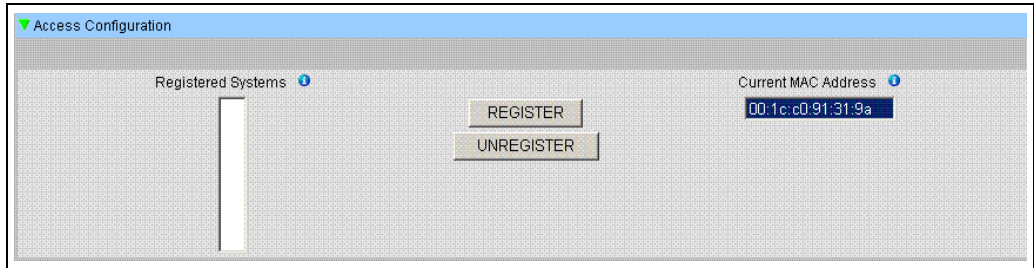

Tankvision Tank Scanner - PC Assignment

Every PC to be connected to the sealed system has to be registered. The PCs are registered under **System** → **Global Settings** → **W&M Seal** → **Access Configuration**. The registered devices are listed with their MAC address in the column on the left. The MAC address of the PC currently used is displayed in the column on the right. Each PC has to be registered individually on every Tankvision box. If no PC is registered in the system, an error message is shown on the display of the Tankvision box once the W+M switch has been flipped.

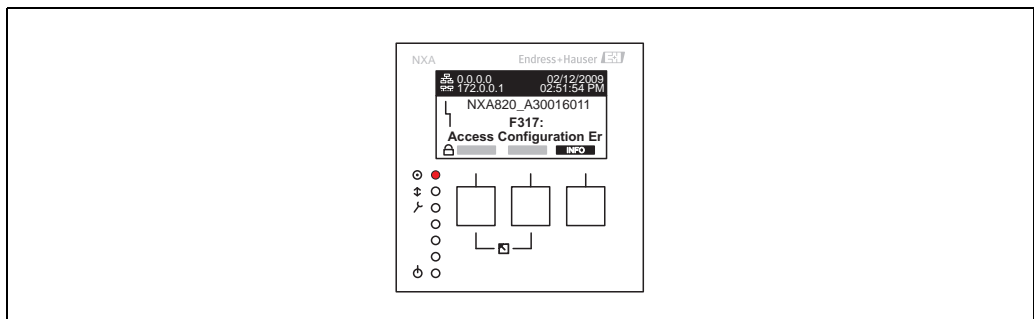

Error Message - No PC Registered in the System

During calibration acceptance, the list must be checked to ensure it only contains the MAC addresses of the Tankvision boxes and the PCs that should access the system. The PCs can be checked, for example, by loading the page above from every PC that should have access to the system and then comparing the MAC addresses (Registered Systems against Current MAC Address). The MAC addresses of the Tankvision box are provided on the nameplate.



*Sealing tank data*

The tank data are sealed individually for every tank. The W+M values are selected under **Tanks** → Select the Tank (Select + Modify) → **Put Tank into Calibrated Status**.

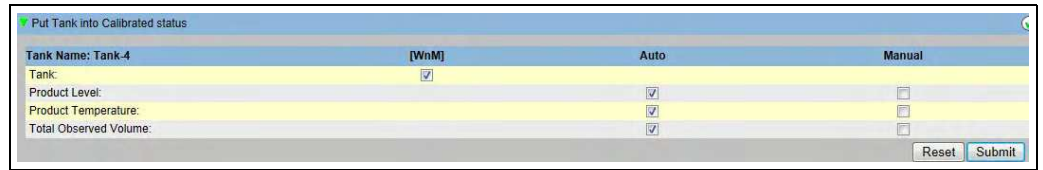

Sealing Tank Data

**i** If the W+M switch is flipped, tanks can be removed from the calibrated status. This changes the calibration checksum. Removing a tank from the sealed system is equivalent to a system modification and must be accepted by an official from the Standards Authority.

*Locking*

The unit is locked by flipping the W+M switch on the Tankvision Tank Scanner NXA820.

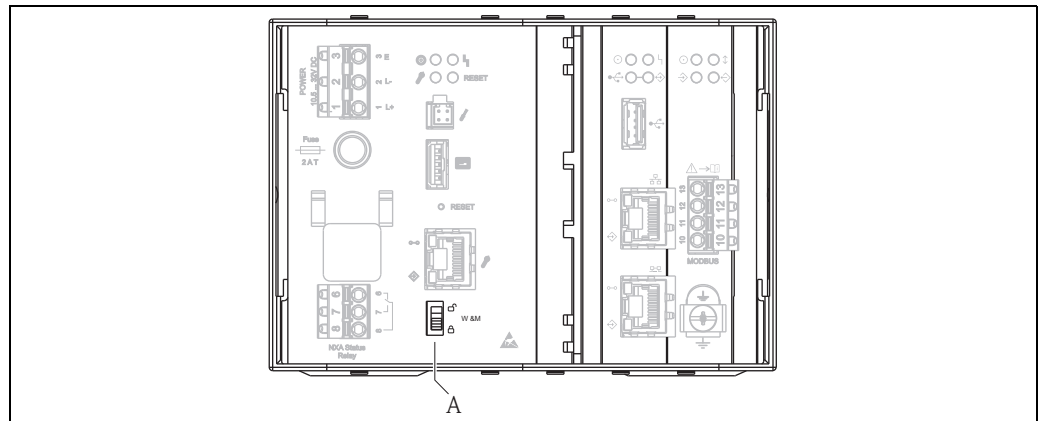

A Tankvision W+M Switch

Flipping the switch means that the settings checked under **Sealing Tank Data** (→ 39) are fixed and can no longer be modified, and that the values specified under **Sealing Tank Data** are displayed as calibrated values by the computers specified under **PC Assignment**. A master checksum is calculated approx. 2 minutes after the W+M switch is flipped. This master checksum can be called up under **System** → **Tank Scanner Unit** → **W&M Seal**. After approximately 2 more minutes, the system performs the first check calculation. The subsequent calculations are then performed every 8 hours.

The following information is displayed:

- Date and time the page was loaded
- W&M switch status
- W&M CRC at sealing time
- Last calculated W&M CRC
- Last calculated CRC's time stamp

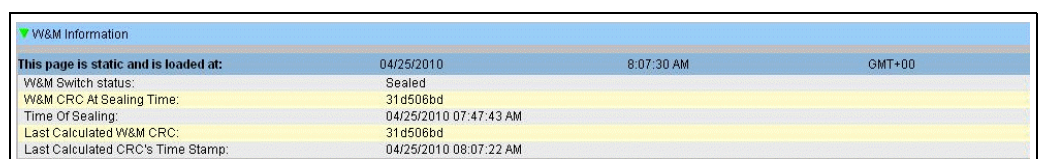

Tankvision W&M Seal

A modified checksum indicates that changes have been made to the system. The checksum must be documented (e.g. by printing out the screenshot, see Figure "Tankvision W&M Seal") and recorded in the acceptance report (e.g. by attaching the printout).

**i** The checksum can be recalculated by switching the Field Scan off and then on again.

#### Checking the W&M display

The following steps must be taken to check the weights and measures display:

- The settings listed under **Sealing Tank Data** (→  39) can no longer be modified.
- A **WM** in front of the values for the **Product Level**, **Product Temperature** and **Total Observed Volume** indicates that the values are calibrated.
- The level and temperature information has to match that of the field devices.

#### Checking the printouts

All printouts from connected printers that cannot be officially verified must bear the annotation **Measured values not calibrated** and no measured values may appear as calibrated.

#### Initial calibration and changes to the Tankvision Data Concentrator NXA821

##### Tank Scanner assignment

The assignment between the Tank Scanner units and the Data Concentrator must be checked under **System** → **Data Concentrator Unit** → **Tank Scanner Unit and Tank Assignment**.

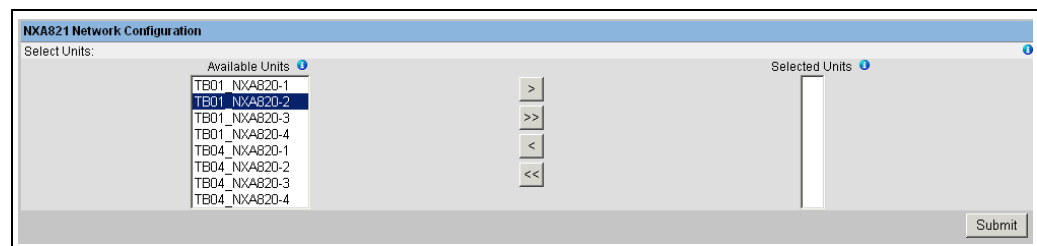

Tankvision Data Concentrator - Tank Scanner Assignment

##### PC assignment

The locking procedure is the same as for the tank scanner (→  39).

#### Stamp points for Tankvision Tank Scanner NXA820 and Data Concentrator NXA821

The stamp points are listed under Point 6 in type approval 4.454/08.10.

## 8.3 Exit the Tankvision system

The user can exit the Tankvision system from any screen.

**i** The session ends automatically after 5 minutes of inactivity (session timeout).

#### To exit the Tankvision system

1. Click the **Logout** link on the Main View. Tankvision displays the login screen.



# 9 Tankvision NXA820 (Interface only) Configuration

## 9.1 Logging into the Tankvision NXA820 (Interface only) system

To integrate a Tankvision Tank Scanner NXA820 (Interface only) unit into the network, proceed as follows:

1. Connect a laptop to the service port of the Tankvision unit. Make sure that the laptop is configured to get a dynamic IP addresses from a DHCP server.

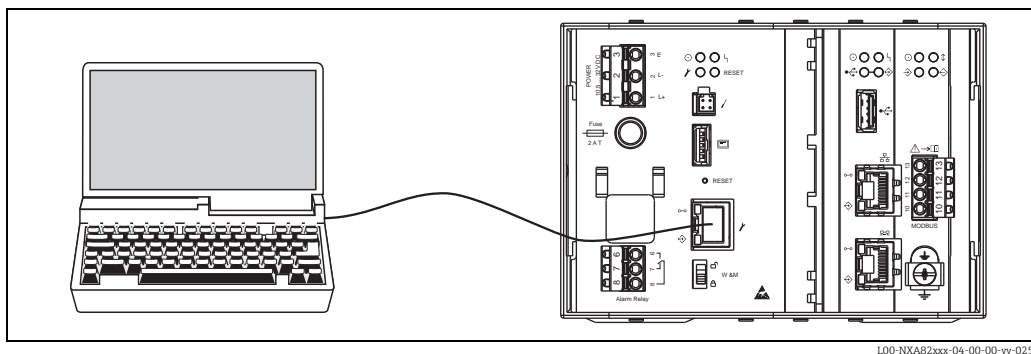

2. Open the internet browser and enter the following URL: <http://192.168.1.1>. The Tankvision login screen appears. The user ID (= User Login Name) and password are defined by the system administrator when adding a user to the system (see BA00339G/00/EN).
3. Login as Supervisor.



| Field    | Description   |
|----------|---|
| User ID  | Enter the appropriate user login name.<br>The user login name is alphanumeric and case sensitive.   |
| Password | Enter the appropriate password.<br>The user password is alphanumeric and case sensitive. It consists of 3 to 8 characters.  |
| Options  | Click the <b>Options</b> button to display the connection options. Available options are <b>Local</b> and <b>Remote</b> . By default, the system selects the <b>Local</b> option. This allows the user to log into the Tankvision system within the network (LAN). The <b>Remote</b> option allows the user to log into the Tankvision system outside the network (Internet). |

- Enter **Super** into **User ID**.
- Enter **Super** into **Password**.
- Click the **Login** button.

Tankvision displays the Home Page.

## 9.2 Overview - Tankvision NXA820 (Interface only) system

In the Overview screen, the primary values and the status information of the tanks connected to the Tank Scanner is displayed.

1. In the Main View, click **Overview**. It expands as follows:

| Tank Name | Level [m] | Temperature [deg C] | Observed Density [kg/m <sup>3</sup> ] |
|-----------|-----------|---------------------|---------------------------------------|
| Tank-1    | +10.670   | +17.0               | +723.0                                |
| Tank-2    | +5.989    | +17.7               | +724.0                                |
| Tank-3    | +7.765    | +18.7               | +721.0                                |
| Tank-4    | +10.776   | +18.6               | +723.0                                |
| Tank-5    | +17.855   | +17.8               | +832.0                                |
| Tank-6    | +19.875   | +17.5               | +833.0                                |
| Tank-7    | +15.234   | +18.2               | +832.0                                |
| Tank-8    | +12.753   | +17.5               | +829.0                                |
| Tank-9    | +19.248   | +19.4               | +824.0                                |
| Tank-10   | +12.584   | +18.2               | +833.0                                |
| Tank-11   | +11.789   | +18.6               | +829.0                                |
| Tank-12   | +3.005    | +20.1               | +833.0                                |
| Tank-13   | +6.547    | +98.8               | +899.0                                |
| Tank-14   | +6.500    | +98.5               | +897.0                                |
| Tank-15   | +2.008    | +95.0               | +895.0                                |

## 9.3 Configuration - Tankvision NXA820 (Interface only) system

- 1. Login to the Tank Scanner NXA820 (Interface only) with "Supervisor" rights to perform settings. To view the settings, "Operator" rights are sufficient.

1. Click  on **Configuration**. The following screen is displayed:

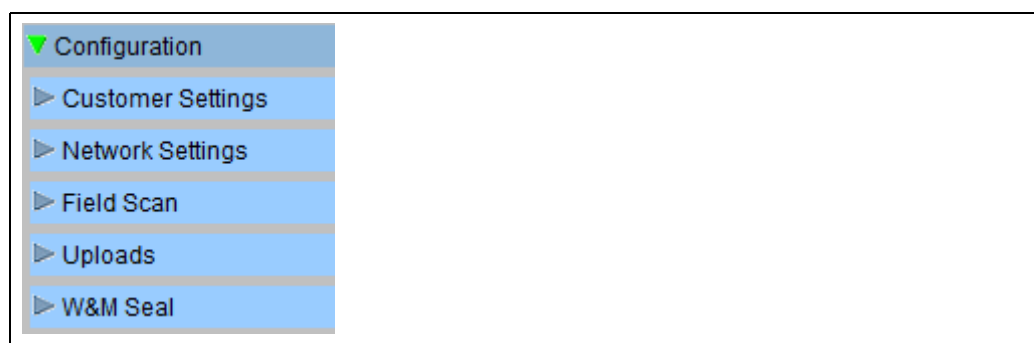

NXA30\_003\_EN

### 9.3.1 Customer settings

1. Click  on **Customer Settings**. The following screen is displayed:

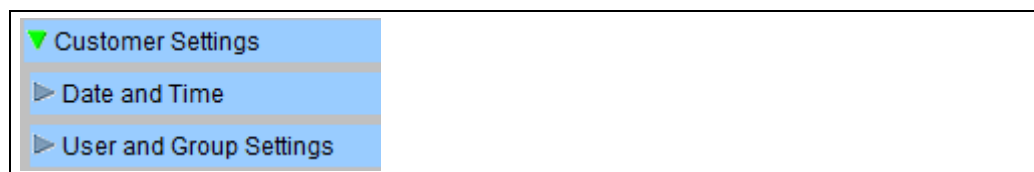

NXA30\_005\_EN

### Date and Time

The system allows the user to configure date, time, time zone and the date-time formats.

#### To Configure Date and Time Settings

1. Click  on **Date and Time**. Tankvision displays the screen as follows:

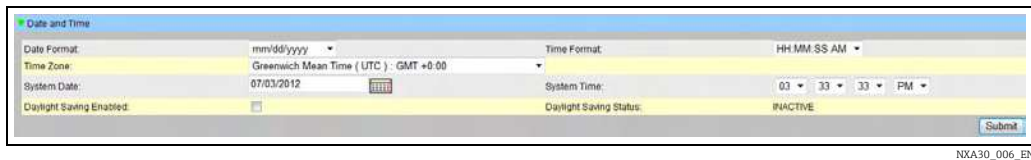

NXA30\_006\_EN

| Field                   | Description   |
|-------------------------|---|
| Date Format             | Select the date format from the drop down list. This field allows you to set the required format for the date. This date format will be used to display the date.                               |
| Time Format             | Select the time format from the drop down list. This field allows you to set the required format for the time. This time format will be used to display the time on all the Tankvision screens. |
| Time Zone               | Select the appropriate time zone from the drop-down list.   |
| System Date             | Enter the current date in the relevant date format. Alternatively, click on the calendar icon to choose the date.   |
| System Time             | Enter the current time in the relevant time format.   |
| Daylight Saving Enabled | Select this check box to enable the user to enter the appropriate daylight saving details. Clear the check box to prevent the user from entering the daylight saving details.                   |
| Daylight Saving Status  | This field displays the daylight saving status. The system displays the <b>ACTIVE</b> status, if the <b>Daylight Saving Enabled</b> check box is selected.                                      |

2. Enter the appropriate information in the relevant fields.
3. Click the **Submit** button. A dialog is displayed that the change of time and date settings will result in a clean-up reset of the system.

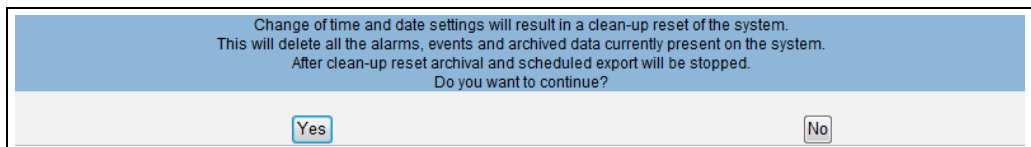

NXA30\_007\_EN

4. Click the **Yes** button to proceed, or click the **No** button to cancel.
5. After saving the settings, the Tankvision unit restarts automatically (wait approx. 3 min).

### User and Group Settings

Login to the Tank Scanner NXA820 as "Supervisor" to perform the user and group settings. For details refer to BA00339G/00/EN.

#### To view the "Manage Users" screen

1. Click  on **User and Group Settings**. Tankvision displays the screen as follows:

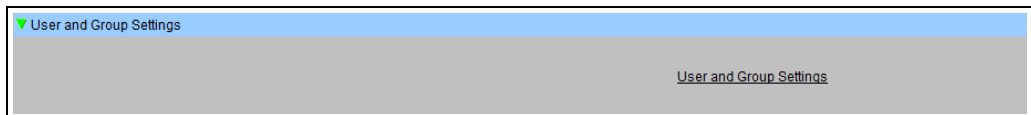

NXA30\_008\_EN

2. Click the **User and Group Settings** button. The **Manage Users** screen is displayed.

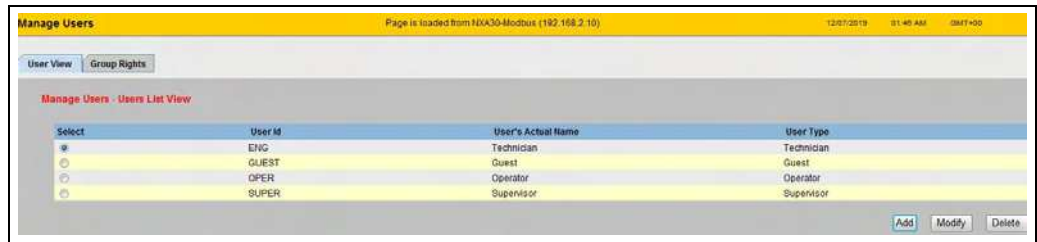

NXA30\_009\_EN

3. For details on how to perform the user and group settings, refer to BA00339G/00/EN.

**i** To exit the **Manage Users** screen, use the **Back** button of the web browser.

**To view the "Group Rights" screen**

1. Click on **User and Group Settings**. Tankvision displays the screen as follows:

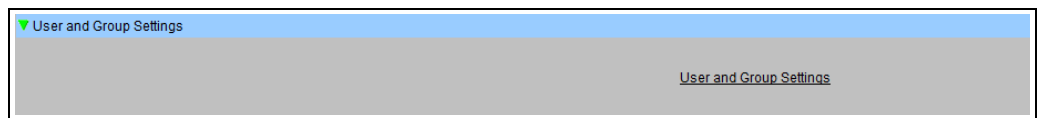

NXA30\_008\_EN

2. Click the **User and Group Settings** button. The **Manage Users** screen is displayed.

3. Select the **Group Rights** tab. The **Group Rights** screen is displayed.

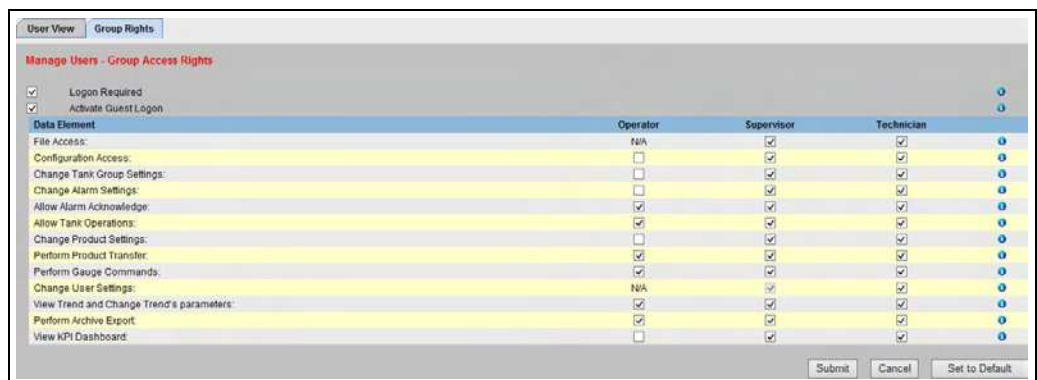

NXA820\_Interface-only\_Manage-Users\_Group-Rights-Tab

4. For details on how to perform the user and group settings, refer to BA00339G/00/EN.

**i** To exit the **Group Rights** screen, use the **Back** button of the web browser.

### 9.3.2 Network settings

You are logged in as "Supervisor".

1. Click on **Network Settings**. Tankvision displays the screen as follows:

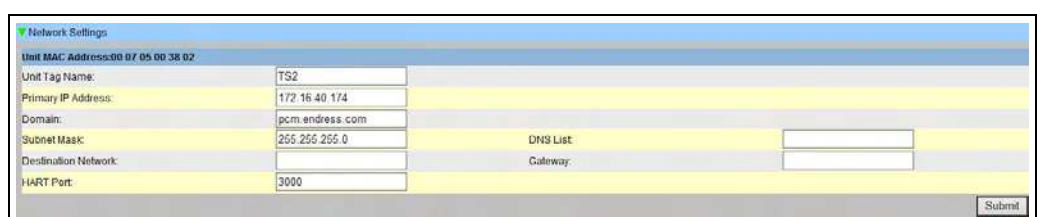

NXA820\_Interface-only\_Network-Settings

2. Enter the appropriate information in the relevant fields.
  - The required values of the parameters depend on your local network configuration. For more information please contact your local network administrator.
  - Detailed information on the individual fields can be found in BA00339G/00/EN, "Tankvision NXA820, NXA821, NXA822 - Description of Instrument Functions".
3. Click the **Submit** button to proceed. The system displays a confirmation box as follows:

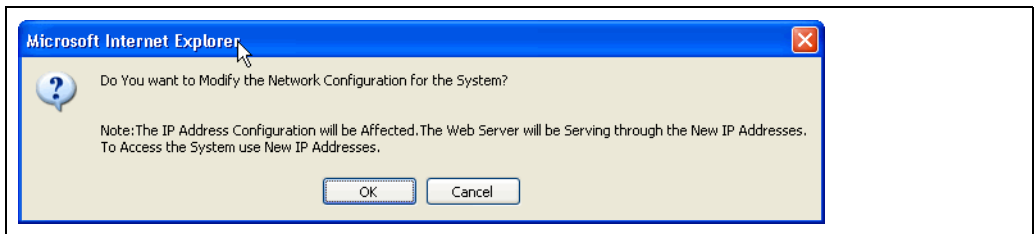

4. Click the **OK** button to proceed, or click the **Cancel** button to exit.
  5. After saving the settings, the Tankvision unit restarts automatically (wait approx. 3 min).
- i** If you don't know the correct IP address, please contact your local network administrator. If you want to use an isolated LAN network, use the IP address 192.168.2.xxx and set the subnet mask to 255.255.255.0

### 9.3.3 Field Scan

The most important function of NXA820 is acquiring measured data from gauges installed in tanks. NXA820 receives measured data by means of field scanning. The measured data comprise tank parameters such as product level, product temperature, pressure, observed density, etc.

#### To Configure the Field Scan Settings

1. Click on **Field Scan**. Tankvision displays the screen as follows:

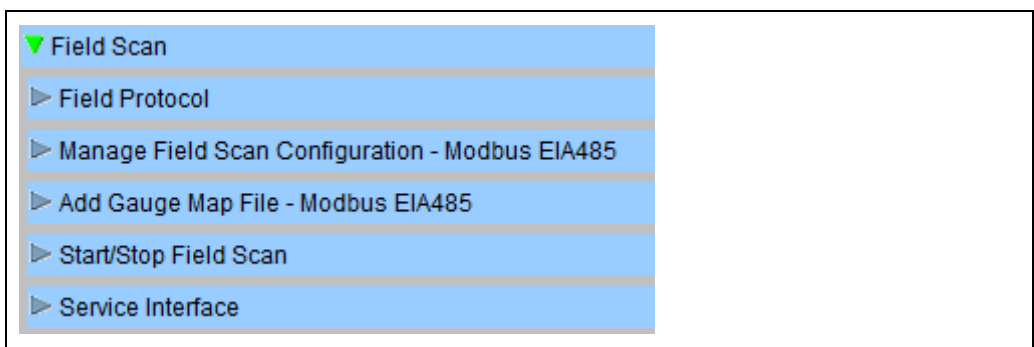

NXA30\_011\_EN

- i** **Manage Field Scan Configuration** is device specific.

#### Field Protocol

In order to perform field scanning, the Field Protocol needs to be configured.

#### To configure the field protocol

1. Click on **Field Protocol**. Tankvision displays the screen as follows:

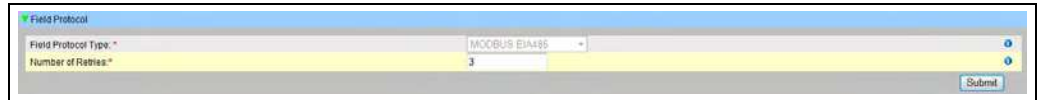

NXA30\_012\_EN

| Field               | Description  |
|---------------------|--|
| Field Protocol Type | Displays the field protocol.   |
| Number of Retries   | Type in the number of retries for the system to initiate Field Scanning. This field indicates the number of retries, before a field scan failure for a gauge is determined by the system. The data type used in this field is numeric. By default, the Tankvision system selects 3 as the Number of Retries. |

2. Enter the appropriate information in the relevant fields.
3. Click the **Submit** button.
4. After saving the settings, Tankvision displays a confirmation message.

### Manage Field Scan Configuration – Modbus EIA 485

The **Manage Field Scan Configuration - Modbus EIA 485** screen displays serial configuration details and gauge configuration details.

In this screen it is possible to select the address and the Modbus map to be used for each gauge.

Before changing the field scan configuration it is necessary to stop the field scan (→ 49).

#### To Manage the Field Scan Configuration using Modbus EIA485

1. Click on **Manage Field Scan Configuration - Modbus EIA485**. Tankvision displays the screen as follows:

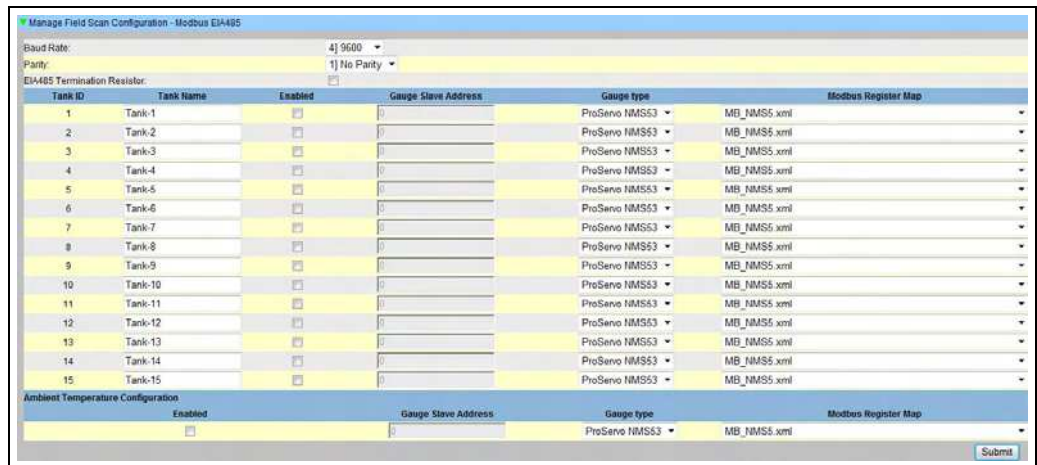

NXA30\_013\_EN

| Field                       | Description  |
|-----------------------------|--|
| Baud Rate                   | Select the baud rate for Modbus communication from the drop down list. Default 9600  |
| Parity                      | Select the parity of the Modbus signal from the drop-down list. Default no parity.   |
| EIA485 Termination Resistor | Enables or disables the termination resistor on the fieldbus for RS485. Only needed for long fieldbus cables to reduce signal reflections.   |
| <b>Tank Configuration</b>   |  |
| Tank ID                     | Each tank in the Tankvision system has a unique numerical value ranging from 1 to 15. This ID represents the network address used by NXA820 for scanning the Tank Data. Cannot be changed. |

| Field                                    | Description   |
|--|---|
| Tank Name                                | Actual tank name, which can be modified here.   |
| Enabled                                  | Select the check box to enable the field scanning of the respective tank.   |
| Gauge Slave Address (DEC)                | This field is enabled, if the "Enabled" check box is selected. Enter the gauge slave address, which is configured between the NXA820 system and the gauge for communication. The gauge slave address can be any number from 1 to 247. |
| Gauge type                               | Select the appropriate Gauge Type from the drop-down list. This field is mandatory.   |
| Modbus Register Map                      | Select the appropriate register map file for tank and gauge (only Registermaps downloaded to Tankvision can be used, → 49).   |
| <b>Ambient Temperature Configuration</b> |   |
| Enabled                                  | Select the check box to configure the ambient temperature.  |
| Gauge Slave Address                      | Enter the slave address of the gauge providing the ambient temperature.   |
| Gauge type                               | Select the appropriate Gauge Type from the drop-down list. This field is mandatory.   |
| Modbus Register Map                      | Select the appropriate Modbus Map File from the drop-down list. If the appropriate Map File is not available it must be added by the <b>Add Gauge Map File</b> function (→ 49).   |

2. Enter the appropriate information in the relevant fields.
3. Click the **Submit** button.
4. After saving the settings, Tankvision displays a confirmation message.

### Manage Field Scan Configuration - V1

The **Manage Field Scan Configuration - V1** screen displays serial configuration details and gauge configuration details.

In this screen it is possible to select the address and the V1 map to be used for each gauge. Before changing the field scan configuration it is necessary to stop the field scan (→ 49).

#### To Manage the Field Scan Configuration using Sakura V1

1. Click  on **Manage Field Scan Configuration - V1**. Tankvision displays the screen as follows:

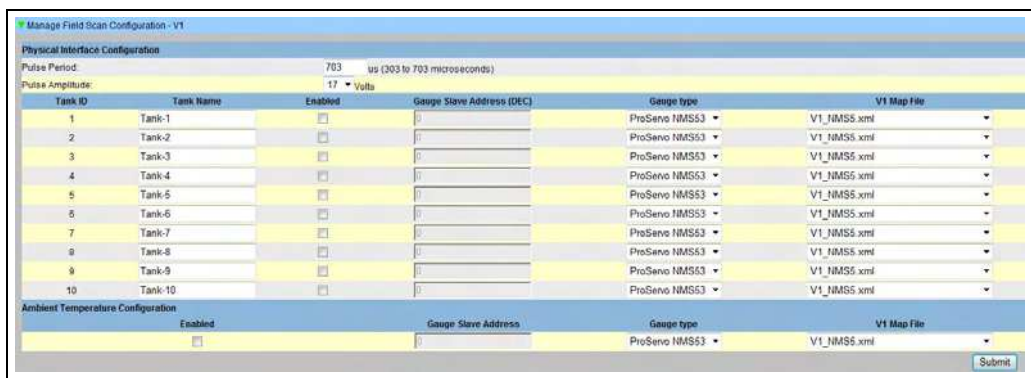

NXA30\_019\_EN

| Field                                   | Description   |
|---|---|
| <b>Physical Interface Configuration</b> |   |
| Pulse Period                            | Defines the pulse period (comparable to the baud rate).   |
| Pulse Amplitude                         | Allows to amplify the signal in case of long cables or poor signal transmission.  |
| <b>Tank Configuration</b>               |   |
| Tank ID                                 | Each tank in the Tankvision system has a unique numerical value ranging from 1 to 10. This ID represents the network address used by NXA820 for scanning the Tank Data. |
| Tank Name                               | Enter the user defined tank name into this field.   |



| Field                                    | Description   |
|--|---|
| Enabled                                  | Select the check box to enable the field scanning of the respective tank.   |
| Gauge Slave Address (DEC)                | This field is enabled, if the <b>Enabled</b> check box is selected.<br>Enter the gauge slave address, which is configured between the NXA820 system and the gauge for communication. The gauge slave address can be any number from 1 to 247. |
| Gauge type                               | Select the appropriate Gauge Type from the drop-down list. This field is mandatory.   |
| V1 Map File                              | Select the appropriate V1 Map File from the drop-down list. If the appropriate Map File is not available it must be added by the <b>Add Gauge Map File</b> function (→ 49).   |
| <b>Ambient Temperature Configuration</b> |   |
| Enabled                                  | Select the check box to configure the ambient temperature.  |
| Gauge Slave Address                      | Enter the slave address of the gauge providing the ambient temperature.   |
| Gauge type                               | Select the appropriate Gauge Type from the drop-down list. This field is mandatory.   |
| V1 Map File                              | Select the appropriate V1 Map File from the drop-down list. If the appropriate Map File is not available it must be added by the <b>Add Gauge Map File</b> function (→ 49).   |

2. Enter the appropriate option in the relevant fields.
3. Click the **Submit** button.
4. After saving the settings, Tankvision displays a confirmation message.

### Manage Field Scan Configuration - WM550

The **Manage Field Scan Configuration - WM550** screen displays serial configuration details and gauge configuration details.

In this screen it is possible to select the address and the Whessoe WM550 map to be used for each gauge.

Before changing the field scan configuration it is necessary to stop the field scan (→ 49).

#### To Manage the Field Scan Configuration using Whessoe WM550

1. Click  on **Manage Field Scan Configuration - WM550**. Tankvision displays the screen as follows:

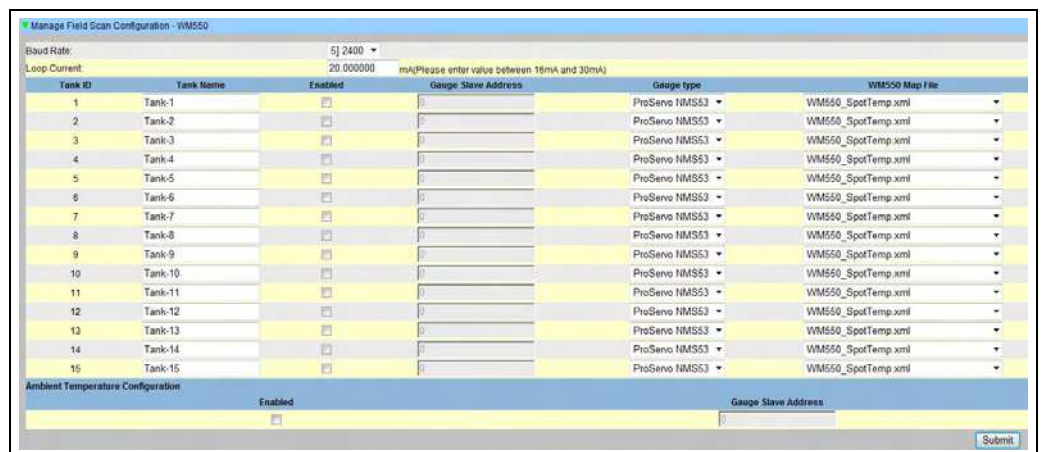

NXA30\_023\_EN

| Field                                   | Description  |
|---|--|
| <b>Physical Interface Configuration</b> |  |
| Baud Rate                               | Defines the WM550 protocol baud rate. Possible values are 300, 600, 1200, 1800, 2400, 4800.  |
| Loop Current                            | This field defines the current in the Whessoe WM550 loop to be set by the internal electronic. This current will be hold by the Master regardless the number of slaves that are connected. Possible values ranges between 16mA and 30mA. |



| Field                     | Description   |
|---------------------------|---|
| <b>Tank Configuration</b> |   |
| Tank ID                   | Each tank in the Tankvision system has a unique numerical value ranging from 1 to 15. This ID represents the network address used by NXA820 for scanning the Tank Data.   |
| Tank Name                 | Enter the user defined tank name into this field.   |
| Enabled                   | Select the check box to enable the field scanning of the respective tank.   |
| Gauge Slave Address (DEC) | This field is enabled, if the <b>Enabled</b> check box is selected. Enter the gauge slave address, which is configured between the NXA820 system and the gauge for communication. The gauge slave address can be any number from 0 to 63 for the Whessoe WM550. |
| Gauge Type                | Select the appropriate Gauge Type from the drop-down list. This field is mandatory.   |
| WM550 Map File            | Select the appropriate WM550 Map File from the drop-down list. If the appropriate map File is not available it must be added by the <b>Add Gauge Map File</b> function.   |

2. Enter the appropriate information in the relevant fields.
3. Click the **Submit** button.
4. After saving the settings, Tankvision displays a confirmation message.

### Add Gauge Map File

For each Modbus field device you need a special map to recognize the device in Tankvision. By default basic maps for Tank Side Monitor (TSM), Proservo NMS are present on the Tankvision Tank Scanner unit. Ask your local Endress+Hauser service to provide the correct map file.

#### To add a Gauge Map File

1. Click  on **Add Gauge Map File - Modbus EIA485/Add Gauge Map File - V1/Add Gauge Map File - WM550**. Tankvision displays the screen as follows:



2. Click the **Browse** button and navigate to the required gauge file. Double-click the file name to enter it into the **Gauge Map File** field.
3. Click the **Download File** button to download the map file to the Tankvision unit.
4. Click the **Submit** button to activate the gauge map file.

### Start/Stop Field Scan

This option allows the user to start the field scan after configuring the field scan. Similarly, the field scan can be stopped at any point of time by using this option.

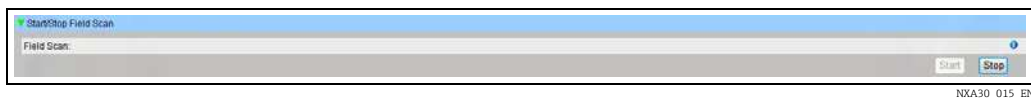

#### To start or stop field scanning

1. Click  on **Start/Stop Field Scan**. Tankvision displays the screen as follows:



2. Click the **Start** button to start the field scanning. The **Start** button is enabled, if the field scan is not started. Once the field scan is started, the **Start** button is disabled, and the **Stop** button is enabled. To stop the field scanning, click the **Stop** button.

### Service Interface

 Please install the **Service Interface** application first. →  52  
Open the **Service Interface** application after successful installation and click the **Start Stat Count** button. Only then, data is displayed in the **Service Interface** screen.

 A separat operating manual for the Service Interface application is available and will be installed on the PC during the application installation process.  
Click the Windows **Start** button and navigate to the **Service Interface** folder, where you will find the manual.

The requests from the Tank Scanner NXA820 and the ensuing responses from the field devices are evaluated in this screen. This screen is only for service purposes.

### To display the service interface

1. Click  on **Service Interface**. Tankvision displays the screen as follows:

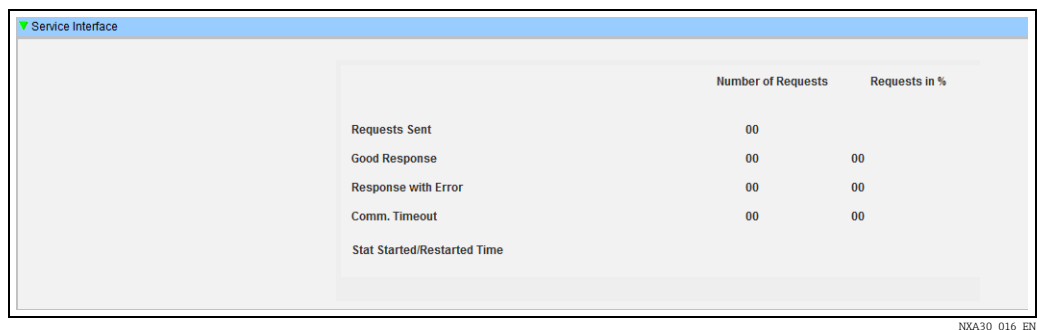

NXA30\_016\_EN

| Field                           | Description   |
|---------------------------------|---|
| Requests Sent                   | The number of total requests sent by the Tank Scanner NXA820.   |
| Good Response                   | The number of requests / percentage of total requests that got a good response from the field device.   |
| Response with Error             | The number of requests / percentage of total requests that got a response with error from the field device.   |
| Comm. Timeout                   | The number of requests / percentage of total requests that got no response from the field device.   |
| Stat Started/<br>Restarted Time | Time at which the evaluation was started; i.e. the time at which the "Start Stat Count" or "Reset Stat Count" button was pressed in the "Service Interface" tool. |

### 9.3.4 Uploads

Via the **Uploads** screen, additional apps can be installed and analysis logfiles can be copied to the PC.

1. Click  on **Uploads**. The following screen is displayed:



NXA820\_Interface-only\_Uploads

### Generic Uploads

Contains generic data to be uploaded from the Tankvision unit, e.g. diagnostic files.

1. Click  on **Generic Uploads**. Tankvision displays the screen as follows:

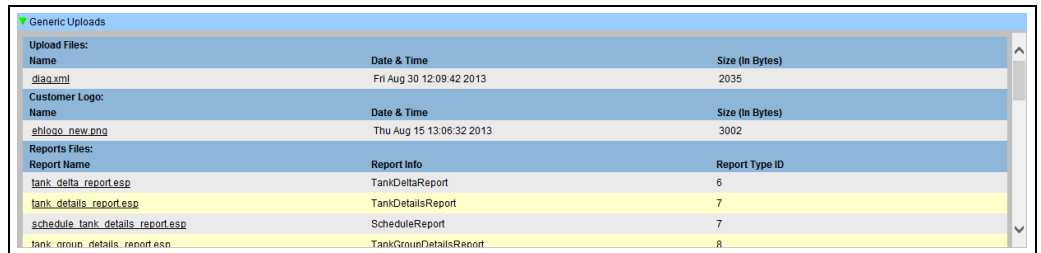

NXA820\_Interface-only\_Uploads\_Generic-Uploads

### Convert Configuration XML File

Converts XML files used in older versions of Tankvision to the latest structure.

#### To convert a Configuration XML file

1. Click  on **Convert Configuration XML File**. Tankvision displays the screen as follows:

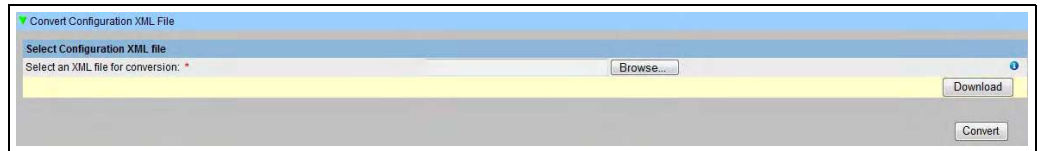

NXA30\_027\_EN

2. Click the **Browse** button and navigate to the required Configuration XML file. Double-click the file name to enter it into the **Select an XML file for conversion** field.
3. Click the **Download** button to download the XML file to the Tankvision unit.
4. Click the **Convert** button to convert the XML file.

### Post Mortem Dumps

Post Mortem Dumps are log files generate when irregular behavior occurs.

Post Mortem Dumps are used for advanced service operations only and should not be used for normal operation.

1. Click  on **Post Mortem Dumps**. Tankvision displays the screen as follows:



NXA30\_028\_EN

### OPC Server

An OPC Server is an application running on a PC serving data to an according OPC Client.

#### To install the OPC Server application

1. Click  on **OPC Server**. Tankvision displays the screen as follows:

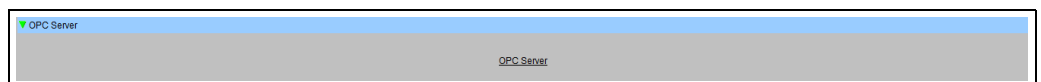

NXA30\_031\_EN

Click the **OPC Server** link and execute the file. Follow the directions on the screen.

### BNR Setup (Backup and Restore)

The Backup and Restore (BNR) tool is an application running on a PC allowing the configuration of the NXA820/821/822 to be saved as safety copy to a hard drive.

#### To setup BNR

1. Click  on **BNR Setup (Backup and Restore)**. Tankvision displays the screen as follows:

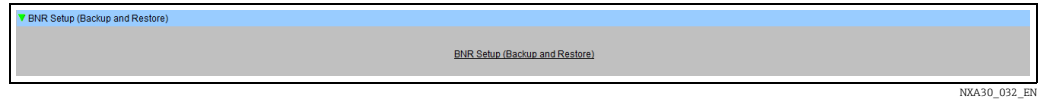

2. Click the **BNR Setup (Backup and Restore)** link and execute the file. Follow the directions on the screen.

### Service Interface

The Service Interface is an application running on a PC allowing the analysis of the field communication of the NXA820.

#### To install the Service Interface

1. Click  on **Service Interface**. Tankvision displays the screen as follows:



2. Click the **Service Interface** link and execute the file. Follow the directions on the screen.

## 9.3.5 W&M Seal

The W&M seal allows you to view the W&M sealing status and to perform the access configuration for W&M secured systems.

#### To Change the W&M Approved Status

1. Click  on **W&M Seal**. Tankvision displays the screen as follows:



| Field                | Description   |
|----------------------|---|
| W&M Information      | Shows detailed information of sealing status for a device: <ul style="list-style-type: none"> <li>■ W&amp;M Switch status</li> <li>■ W&amp;M CRC at sealing time</li> <li>■ Time of sealing</li> <li>■ Last calculated W&amp;M CRC</li> <li>■ Last calculated CRC's time stamp</li> </ul> |
| Access Configuration | Registration page to configure access rights for a PC that can access the device after sealing.   |

### W&M Information

1. Click  on **W&M Information**. Tankvision displays the screen as follows:

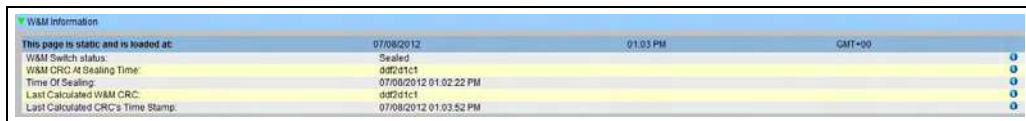

NXA30\_036-2\_EN

| Field                                 | Description   |
|---------------------------------------|---|
| This page is static and is loaded at: | Displays the date and time when the screen was locked. This is a static page meaning no auto update is running.   |
| W&M switch status                     | Displays the current W&M switch status. The status can be sealed (closed W&M switch) or unsealed (open W&M switch).   |
| CRC at sealing time                   | A checksum is calculated with closing the W&M switch. This checksum is displayed in this field.   |
| Time of sealing                       | Displays the date and time the sealing took place.  |
| Last Calc. W&M CRC                    | Displays the latest calc. W&M checksum. The checksum is recalculated on a regular basis. In case of an mismatch of the recalculated checksum with the initial checksum, the system was manipulated. |
| Last Calc. W&M CRC time stamp         | Displays date and time of the last calculated W&M checksum.   |

### Access Configuration

In sealed systems only registered Users/PC's are allowed to have access to the system functionality. The access configuration provides the possibility to ensure the access. The access configuration is based on MAC Address.



NXA30\_037\_EN

| Field               | Description  |
|---------------------|--|
| Registered Systems  | <p>Displays the MAC Address of the currently registered PC.</p> <ul style="list-style-type: none"> <li>Registered: Registers the PC which is connected to the system (current workstation). The PC's must be in the same Network as Tankvision (no router / gateway in between). Registration must be performed from every PC which should have access to the system individually.</li> <li>Unregistered: To unregister PC(s) mark them in the list on the left hand side (select several by pressing <b>Ctrl</b> and marking them) and click unregister. The unregistered PC's will not have access to the system after sealing.</li> </ul> |
| Current MAC Address | Displays the current MAC Address of the workstation.   |

 This section is sealed for editing after switching the W&M switch to close.

### 9.3.6 Configuration of W+M systems

See configuration of W+M systems (→  33) and follow the required steps for NXA820 Interface only (Field Device assignment, PC assignment and Locking).

## 9.4 Service - Tankvision NXA820 (Interface only)

1. Click  on **Service**. The following screen is displayed:

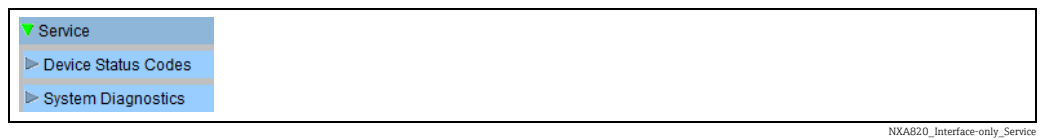

### 9.4.1 Device Status Codes

The Device Status Codes are intended only for service tasks. Refer to BA00339G/00/EN for a detailed list of the status codes.

1. Click  on **Device Status Codes**. The following screen is displayed:

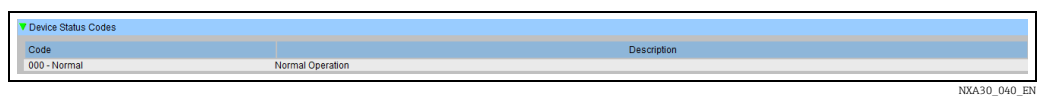

### 9.4.2 System Diagnostics

The system diagnostic tools are intended for service operations only and should not be used for standard operations of the Tankvision system.

1. Click  on **System Diagnostics**. The following screen is displayed:

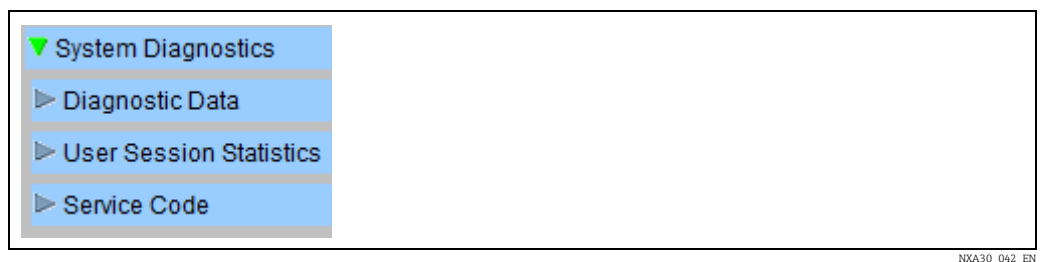

#### Diagnostic Data

Diagnostic data provides general status and diagnostic information like the number of times restarted and the temperature limits reached. This is a valuable tool to recognize unsafe conditions that could become a future failure.

1. Click  on **Diagnostic Data**. The following screen is displayed:

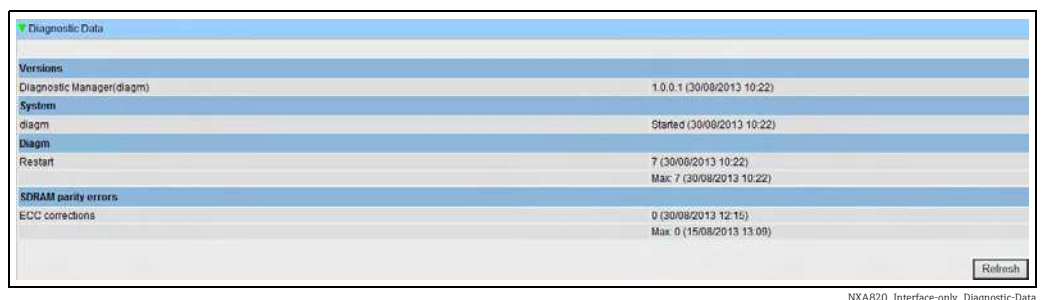

#### User Session Statistics

Provides useful information of users and user login activities. It allows to know which user logged in last via a **Last Accessed Time** stamp.

1. Click  on **User Session Statistics**. The following screen is displayed:

| User No. | Login ID | User Type  | Last Accessed Time      |
|----------|----------|------------|-------------------------|
| 1        | SUPER    | Supervisor | Sun Jul 8 12:53:09 2012 |
| 2        | SUPER    | Supervisor | Sun Jul 8 12:59:42 2012 |

NXA30\_043\_EN

### Service Codes

Service Codes is a service area that allows to execute predefined tasks by the operative system. As service codes are tasks like generate advanced diagnostic information, restart the unit, apply a historical archive clean up reset or execute a factory default settings reset.

1. Click on **Service Code**. The following screen is displayed:

| Service Code | Script File        | Output File       | Description                   |
|--------------|--------------------|-------------------|-------------------------------|
| PROCESSLOG   | processlog.sh      | process_log_#.txt | Upload Process Log            |
| MEMORYLOG    | memorylog.sh       | memory_log_#.txt  | Upload Memory Log             |
| CPUUSAGE     | cpuusage.sh        | cpu_usage_#.txt   | Upload CPU Usage Log          |
| HAMLLOG      | hamlog.sh          | ham_log_#.txt     | Upload HAM Log                |
| RESET        | serreset.sh        | reset_log_#.txt   | Perform Device Reset          |
| CLEANUPRESET | sercleanup.sh      | reset_log_#.txt   | Perform Cleanup Reset         |
| FACTORYRESET | serfactoryreset.sh | reset_log_#.txt   | Perform Factory Reset         |
| INETD        | serinetd.sh        | inetd_log_#.txt   | Inet Daemon                   |
| DSCMLOG      | serdscmlog.sh      | dscm_log_#.txt    | Upload Device Status Code Log |

NXA30\_044\_EN

## 9.5 Exit the Tankvision system

The user can exit the Tankvision system from any screen.

- The session ends automatically after 5 minutes of inactivity (session timeout).

### To exit the Tankvision system

1. Click the **Logout** link on the Main View. Tankvision displays the login screen.

## 10 Trouble shooting

### 10.1 Test network connection

If a Tankvision unit can not be accessed from the operators computer you can test the network connection using the 'ping' command:

1. Click the Window **Start** button and select **Execute**. The **Run** dialog window appears.
2. Enter cmd into the **Open** field. The Windows Command Prompt window appears.
3. Try to ping the Tankvision until by typing the following into the command prompt line:  
ping xxx.xxx.xxx.xx  
Here xxx.xxx.xxx.xx is the IP address of the Tankvision unit.
4. If the pinging is successful and the computer receives an answer from the Tankvision unit, a message appears as follows:

```

C:\Documents and Settings\pcn>ping 169.254.135.53
Pinging 169.254.135.53 with 32 bytes of data:
Reply from 169.254.135.53: bytes=32 time<10ms TTL=255
Reply from 169.254.135.53: bytes=32 time<10ms TTL=255
Reply from 169.254.135.53: bytes=32 time<10ms TTL=255
Reply from 169.254.135.53: bytes=32 time<10ms TTL=255

Ping statistics for 169.254.135.53:
    Packets: Sent = 4, Received = 4, Lost = 0 (0% loss),
    Approximate round trip times in milli-seconds:
        Minimum = 0ms, Maximum = 0ms, Average = 0ms
C:\Documents and Settings\pcn>_
    
```

5. If the pinging fails, the message "Destination host unreachable" or "Request timed out" will appear: This means that the network is not working properly.

```

C:\Documents and Settings\pcn>ping 169.254.135.53
Pinging 169.254.135.53 with 32 bytes of data:
Destination host unreachable.
Destination host unreachable.
Destination host unreachable.
Destination host unreachable.

Ping statistics for 169.254.135.53:
    Packets: Sent = 4, Received = 0, Lost = 4 (100% loss),
    Approximate round trip times in milli-seconds:
        Minimum = 0ms, Maximum = 0ms, Average = 0ms
C:\Documents and Settings\pcn>_
    
```

```

C:\Documents and Settings\pcn>ping 169.254.135.53
Pinging 169.254.135.53 with 32 bytes of data:
Request timed out.
Request timed out.
Request timed out.
Request timed out.

Ping statistics for 169.254.135.53:
    Packets: Sent = 4, Received = 0, Lost = 4 (100% loss),
    Approximate round trip times in milli-seconds:
        Minimum = 0ms, Maximum = 0ms, Average = 0ms
C:\Documents and Settings\pcn>
    
```



Possible causes are:

- Wrong network settings (e.g. wrong IP address) in the Tankvision unit or the computer
- Hardware problems (e.g. cable break or improper plugging of the cables)
- Missing power supply of the Tankvision unit

## 10.2 Resets

### 10.2.1 Types of Resets

- **Reset:**  
Restart the system without any additional action.
- **Cleanup:**  
Resets archival data, alarms and events without changing the configuration.
- **Factory:**  
Resets the software to factory default settings, all data is getting lost including network settings.

### 10.2.2 Hardware Reset

- Push the reset button on the front panel of the device and release it in one of the following specified reset windows indicated by the Reset LED.
- Releasing the button in a LED ON window has no effect at all, the system keeps on running.

| Reset           |            | Cleanup             |             | Factory              |          |
|-----------------|------------|---------------------|-------------|----------------------|----------|
| LED flash<br>Hz | LED ON     | LED flash<br>2,5 Hz | LED ON      | LED flash<br>1,25 Hz | LED ON   |
| 0...5 sec       | 5...10 sec | 10...15 sec         | 15...20 sec | 20...25 sec          | > 25 sec |

### 10.2.3 User Interface Reset

- Use a Service Code script to perform a reset
- Path: Global Settings / System Diagnostics / Service Code
- Enter one of the given Service Codes and press submit



## 11 Return

The measuring device must be returned if repairs or a factory calibration are required, or if the wrong measuring device has been ordered or delivered. According to legal regulations, Endress+Hauser, as an ISO-certified company, is required to follow certain procedures when handling returned products that are in contact with medium. To ensure swift, safe and professional device returns, please read the return procedures and conditions on the Endress+Hauser website at [www.services.endress.com/return-material](http://www.services.endress.com/return-material)

## Index

### C

Configuration of W+M systems . . . . . 33

### D

Data Concentrator NXA821  
     Specific settings . . . . . 32  
 Delivery content . . . . . 9  
 Device version . . . . . 8  
 Dimensions . . . . . 9  
 DIN-rail housing . . . . . 9

### E

Exit the Tankvision system . . . . . 40, 55

### F

Field connection . . . . . 15

### H

Home Page  
     NXA820 Interface only . . . . . 24  
     NXA820 with calculations/821/822 . . . . . 23  
 Host connection  
     Modbus Serial, EIA/TIA-485 (RS485) . . . . . 20  
     Modbus TCP/IP (via System LAN port) . . . . . 20  
 Host Link NXA822  
     Specific settings . . . . . 33

### I

Icons . . . . . 3  
 Incoming acceptance . . . . . 9  
 Installation . . . . . 9  
 Installation check . . . . . 10  
 Installation conditions . . . . . 10

### J

Java Runtime Environment (JRE) . . . . . 22  
     Installation . . . . . 22  
     Settings . . . . . 22

### L

LAN connection . . . . . 14

### M

MAC Address . . . . . 53  
 Mounting . . . . . 10

### O

Operation station settings . . . . . 21  
 Order code . . . . . 8

### P

Power supply . . . . . 13  
 Proxy server . . . . . 21

### R

Return . . . . . 58

### S

Safety icons . . . . . 3  
 Status Relay . . . . . 14  
 Storage . . . . . 9  
 Symbols . . . . . 3

### T

Tank Scanner NXA820 with calculations  
     Specific settings . . . . . 31  
 Tankvision NXA820 Interface only  
     Configuration . . . . . 41  
     Configuration of W+M systems . . . . . 53  
     Customer settings . . . . . 42  
     Device Status Codes . . . . . 54  
     Field Scan . . . . . 45  
     Logging into . . . . . 41  
     Network settings . . . . . 44  
     Overview . . . . . 42  
     Service . . . . . 54  
     System Diagnostics . . . . . 54  
     Uploads . . . . . 50  
     W&M Seal . . . . . 52  
 Tankvision NXA820 with calculations/821/822  
     Common settings . . . . . 28  
     Configuration . . . . . 27  
     Logging into . . . . . 27  
     Network settings . . . . . 28  
     Subscription Store definition . . . . . 30  
 Tankvision NXA820/821/822  
     User Interface . . . . . 23  
 Terminal assignment . . . . . 12, 15, 18  
 Trademarks . . . . . 8  
 Transport . . . . . 9  
 Trouble shooting . . . . . 56  
     Resets . . . . . 57  
     Test network connection . . . . . 56

### W

Wiring . . . . . 11  
 Wiring example  
     NXA820 "Interface only" . . . . . 12  
     NXA820/821/822 . . . . . 11



[www.addresses.endress.com](http://www.addresses.endress.com)

---