

Operating Instructions

Gamma Modulator FHG65/ Synchronizer FHG66

Radiometric Measurement

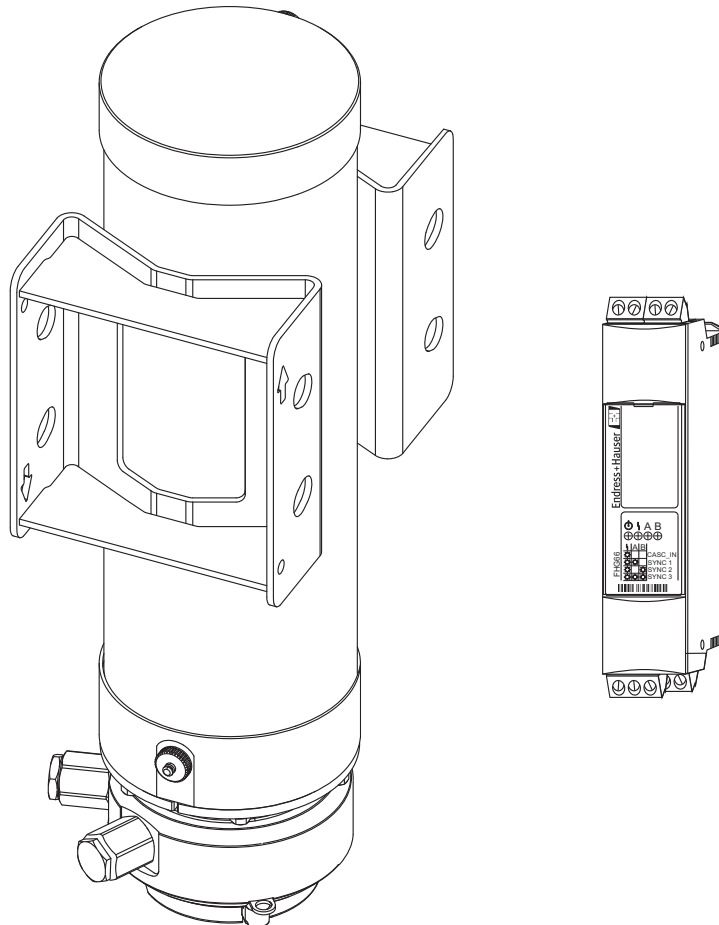

System requirements at Gammapilot M FMG60

In order to be able to evaluate the signal created by the Gamma Modulator FHG65, the Gammapilot M FMG60 must be equipped with at least one of the following software versions:

- HART electronics
 - For SIL devices of short level limit detectors (200 or 400 mm): SW 01.02.02 or higher
 - For all other device types: SW 01.03.02 or higher
- PROFIBUS PA electronics
 - SW 01.03.02 or higher
- FOUNDATION Fieldbus electronics
 - SW 01.03.02 or higher

Table of contents

1	Safety instructions	4
1.1	Designated use	4
1.2	Installation, commissioning and operation	4
1.3	Hazardous area	4
1.4	Notes on radiation protection	5
1.5	Symbols	8
2	Identification	9
2.1	FHG65 nameplate	9
2.2	Ordering information	9
2.3	Scope of delivery	10
2.4	CE mark, Declaration of Conformity	10
2.5	Overspill protection	10
3	Installation	11
3.1	Incoming acceptance, transport and storage	11
3.2	Installation instructions	12
3.3	Post-installation check	19
4	Wiring	20
4.1	Potential equalization	20
4.2	Cable entries	20
4.3	Terminal assignment	21
4.4	Alarm output	22
4.5	Post-connection check	22
5	Commissioning at the Gammapilot M FMG60	23
5.1	Configuring the beam type	23
5.2	Recalibration	23
6	Maintenance and repair	24
6.1	Maintenance	24
6.2	Cleaning	24
6.3	Repair	24
6.4	Return	24
6.5	Disposal	24
6.6	Contact addresses at Endress+Hauser	24
7	Technical data	25
7.1	Additional technical data	25
7.2	Supplementary Documentation	25
8	Accessories: Synchronizer FHG66	26
8.1	Synchronizer FHG66	26

1 Safety instructions

1.1 Designated use

The Gamma Modulator FHG65 is used to optimize the measuring signal during radiometric level measurement, limit measurement, density measurement and concentration measurement.

The Synchronizer FHG66 is used to synchronize multiple Gamma Modulators FHG65 that are used together in a measuring point.

Resulting from incorrect use, or from use other than that designated, the operational safety of the measuring device can be suspended. The manufacturer accepts no liability for damages resulting from this.

1.2 Installation, commissioning and operation

The measuring system is designed to meet state-of-the-art safety requirements and complies with applicable standards and EC regulations. If used incorrectly or for applications for which it is not intended, however, it can be a source of application-related danger, e.g. product overflow due to incorrect installation or configuration. For this reason, installation, connection to the electricity supply, commissioning, operation and maintenance of the measuring system must only be carried out by trained, qualified specialists authorized to perform such work by the facility's owner-operator. The specialist staff must have read and understood these Operating Instructions and must follow the instructions they contain. Modifications and repairs to the measuring system are permissible only if they are expressly approved in the Operating Instructions.

1.3 Hazardous area

If using the measuring system in hazardous areas, the appropriate national standards and regulations must be observed. The device is accompanied by separate Ex documentation, which is an integral part of this documentation. The installation regulations, connection values and safety instructions listed in this document must be observed.

- Ensure that all personnel are suitably qualified.
- Measuring point requirements with regard to measurement and safety must be observed.

1.4 Notes on radiation protection

During radiometric measurement, a radioactive source - contained in a source container - is used. When working with radioactive sources, the following instructions have to be observed:

1.4.1 Basic radiation protection instructions

⚠ WARNING

When working with radioactive sources, all unnecessary radiation exposure should be avoided. All unavoidable radiation exposure should be kept to a minimum. Three important measures are applied to achieve this:

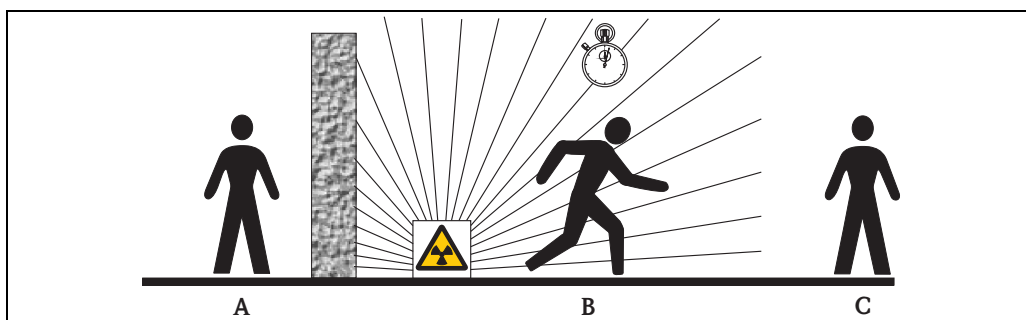

A *Screening*
B *Time*
C *Distance*

A0016373

Shielding

Ensure the best possible shielding between the emitter and yourself as well as all other individuals. Effective shielding is provided by source containers (FQG60, FQG61/FQG62, FQG63, QG2000) and all high-density materials (lead, iron, concrete).

⚠ CAUTION

When working with source containers, all the instructions for mounting and handling outlined in the associated Operating Instructions must be observed.

Time

Remain as short as possible in the area exposed to radiation.

Distance

Keep as far away as possible from the radiation source. The radiation intensity decreases quadratically with the distance from the radiation source.

1.4.2 Legal regulations for radiation protection

The handling of radioactive emitters is legally controlled. The radiation protection regulations of the country in which the plant is operated are to be strictly observed. In the Federal Republic of Germany, the current Radiation Protection Directive applies. The following points, in particular, are important for radiometric measurement:

Handling permit

A handling permit is required for operating a plant which uses gamma radiation. Application for the permit must be made to the local state government or the authority responsible (State Offices for Environmental Protection, Trade Inspection Offices, etc.). The Endress+Hauser sales organization will be pleased to help you obtain the permit.

Radiation protection officer

The operator of the plant must nominate a radiation protection officer who has the necessary specialist knowledge and who is responsible for observing the Radiation Protection Directive and all procedures for radiation protection. Endress+Hauser offers training courses in which the necessary specialist knowledge can be acquired.

Control zone

Only persons who are exposed to radiation during the course of their job and are subject to official personal dose monitoring procedures may work in control zones (i.e. areas where the local dose rate exceeds a specific value). The limit values for the control zone are specified in the current Radiation Protection Directive applicable to your area.

The Endress+Hauser sales organization will be pleased to provide further information on radiation protection and regulations in other countries.

1.4.3 Behavior in the event of an incident

Emergency measures

If the source container or the emitter is damaged in an accident or another unforeseen event, or if the emitter is lost by other means, the following emergency measures must be initiated immediately:

- Inform the radiation protection officer immediately.
- All employees must leave the danger area immediately. The area around the measuring point must be cordoned off and marked accordingly.
- Production must be halted immediately if there is a risk that radioactive material has got into the material being measured. Material which might have been contaminated must be secured and may not be further used before it has been inspected.
- All persons involved in cleaning up (fire brigade, industrial safety unit etc.) must be informed of the danger of radiation.

Reporting to the responsible authority

As soon as the emergency measures have been initiated, the authorities responsible for radiation must be informed by the radiation protection officer.

1.4.4 Procedures after terminating the application

Internal measures

As soon as a radiometric measuring device is no longer required, the radiation source at the source container must be switched off. The source container must be disassembled in accordance with all relevant regulations and stored in a lockable room which has no through-traffic. The appropriate authorities responsible must be informed of these measures. The access area to the storage room must be measured and labeled accordingly. The radiation protection officer is responsible for protecting against theft. The emitter in the source container must never be scrapped with other parts of the plant.

Return

Federal Republic of Germany

Contact your Endress+Hauser Sales Center to organize the return of the radiation source for inspection with a view to reuse or recycling by Endress+Hauser.

Other countries

Contact your Endress+Hauser Sales Center or the appropriate authority to find a way of returning the radiation source nationally. If return is not possible domestically, the further procedure must be agreed with the Endress+Hauser Sales Center concerned. The destination airport for potential returns is Frankfurt, Germany.

Conditions

The following conditions must be met before returning the material:





- An inspection certificate no more than three months old confirming the leak-tightness of the radiation source must be in the possession of Endress+Hauser (wipe test certificate).
- The serial number of the the source capsule, type of radiation source (^{60}Co or ^{137}Cs), activity and model of radiation source must be specified. This data may be found in the documents supplied with the radiation source.
- The material must be returned in type-tested type-A packaging (IATA rules) (see TI00439F/00/EN).

1.4.5 Using source containers

Strict compliance with the safety instructions and instructions on installing, mounting and operating is mandatory. For details please refer to the associated Operating Instructions.

1.5 Symbols



1.5.1 Safety symbols

Symbol	Meaning
 A0011189-DE	DANGER! This symbol alerts you to a dangerous situation. Failure to avoid this situation will result in serious or fatal injury.
 A0011190-DE	WARNING! This symbol alerts you to a dangerous situation. Failure to avoid this situation can result in serious or fatal injury.
 A0011191-DE	CAUTION! This symbol alerts you to a dangerous situation. Failure to avoid this situation can result in minor or medium injury.
 A0011192-DE	NOTICE! This symbol contains information on procedures and other facts which do not result in personal injury.



1.5.2 Electrical symbols

Symbol	Meaning
 A0018339	Protective ground connection A terminal which must be connected to ground prior to establishing any other connections.

1.5.3 Symbols for certain types of information

Symbol	Meaning
 A0011182	Allowed Indicates procedures, processes or actions that are allowed.
 A0011184	Forbidden Indicates procedures, processes or actions that are forbidden.
 A0015484	Reference to page Refers to the corresponding page number.
1. , 2. , ...	Series of steps

1.5.4 Symbols in graphics

Symbol	Meaning
1, 2, 3, 4, ...	Item numbers
1. , 2. , ...	Series of steps
A, B, C, D, ...	Views
 A0011187	Hazardous area Indicates a hazardous area.
 A0011188	Safe area (non-hazardous area) Indicates a non-hazardous location.

2 Identification

2.1 FHG65 nameplate

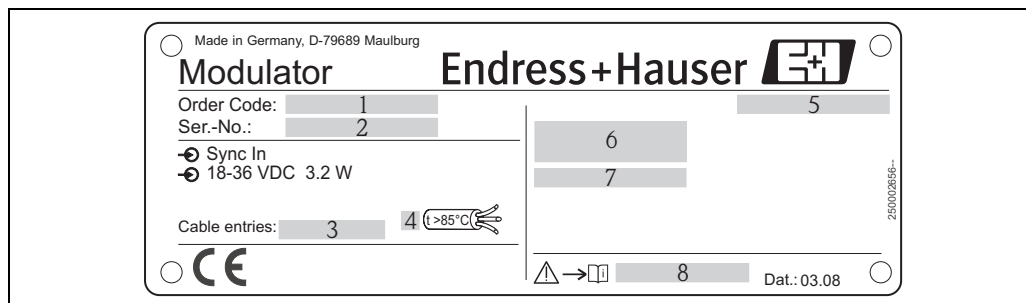

- | | | | |
|---|--|---|---|
| 1 | Order code (see product structure) | 5 | Degree of protection |
| 2 | Serial number | 6 | Certificate data |
| 3 | Cable entries | 7 | Permitted ambient temperature |
| 4 | Required connection cable temperature resistance | 8 | Reference to additional, safety-related documentation |

2.2 Ordering information

Detailed ordering information is available from the following sources:

- In the Product Configuration on the Endress+Hauser website: www.endress.com → Select country → Instruments → Select device → Product page function: Configure this product
- From your Endress+Hauser Sales Center: www.endress.com/worldwide



Product Configurator - the tool for individual product configuration

- Up-to-the-minute configuration data
- Depending on the device: Direct input of measuring point-specific information such as measuring range or operating language
- Automatic verification of exclusion criteria
- Automatic creation of the order code and its breakdown in PDF or Excel output format
- Ability to order directly in the Endress+Hauser Online Shop

2.3 Scope of delivery

Gamma Modulator FHG65

2.4 CE mark, Declaration of Conformity

The device is designed to meet state-of-the-art safety requirements, has been tested and left the factory in a condition in which it is safe to operate. The device complies with the applicable standards and regulations as listed in the EC Declaration of Conformity and thus meets the statutory requirements of the EC directives. Endress+Hauser confirms the successful testing of the device by affixing to it the CE mark.

2.5 Overspill protection

- May be applied in max-level applications in connection with the Gammapilot M FMG60 (200/400 mm) in SIL 2/3 according to IEC 61508.
- Not tested for overspill protection according to WHG

3 Installation

3.1 Incoming acceptance, transport and storage

3.1.1 Incoming acceptance

Check the packaging and the contents for damage.

Check the shipment, make sure nothing is missing and that the scope of supply matches your order.

3.1.2 Transporting to the measuring point

▲ CAUTION

Follow the safety instructions and transport conditions for devices weighing more than 18 kg (39.69 lbs). Do not lift the modulator by the housing top in order to transport it.

3.1.3 Storage

Pack the device so that is protected against impact for storage and transport. The original packaging provides optimum protection. Permitted storage temperature (without water in water cooling jacket): -40 to +75 °C (-40 to +167 °F).

3.2 Installation instructions

3.2.1 Installation position/operating principle

In a radiometric measuring point, the Gamma Modulator FHG65 is mounted in front of the radiation exit channel of the source container. It contains a shaft slotted along the longitudinal axis. This shaft rotates continuously and alternately screens off the gamma beam at a frequency of 1 Hz or allows it through.

Due to this frequency, the useful beam differs from fluctuating ambient interference radiation and from interference radiation occurring sporadically (e.g. from nondestructive material testing). Using a frequency filter, the Gammapilot M can thus separate the useful signal from interference radiation. In this way, it is possible to continue measuring even if interference radiation occurs, which, in turn, increases the measuring certainty and system availability.

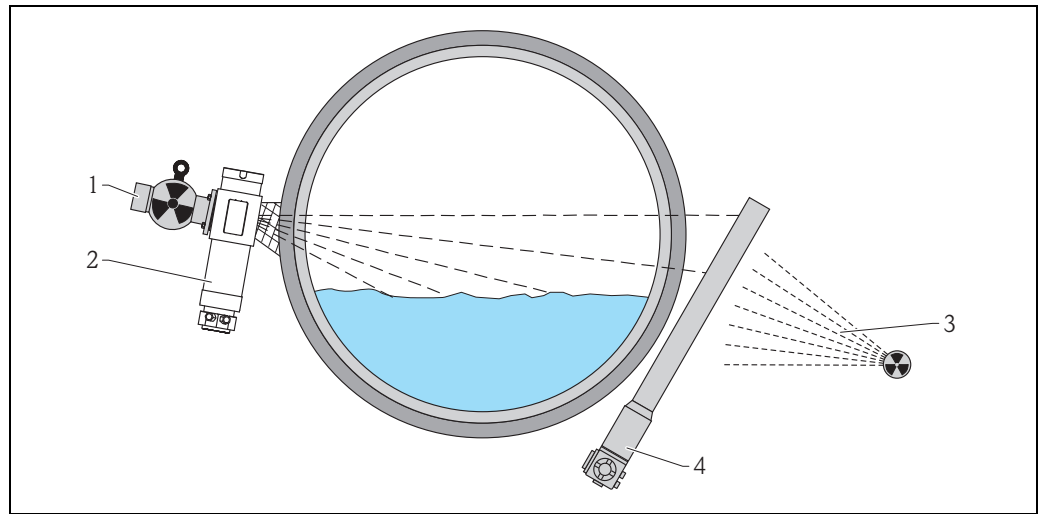

A0018245

- 1 FQG61, FQG62
- 2 FHG65
- 3 Interference radiation
- 4 Gammapilot M FMG60

3.2.2 FHG65 installation dimensions

Gamma modulator

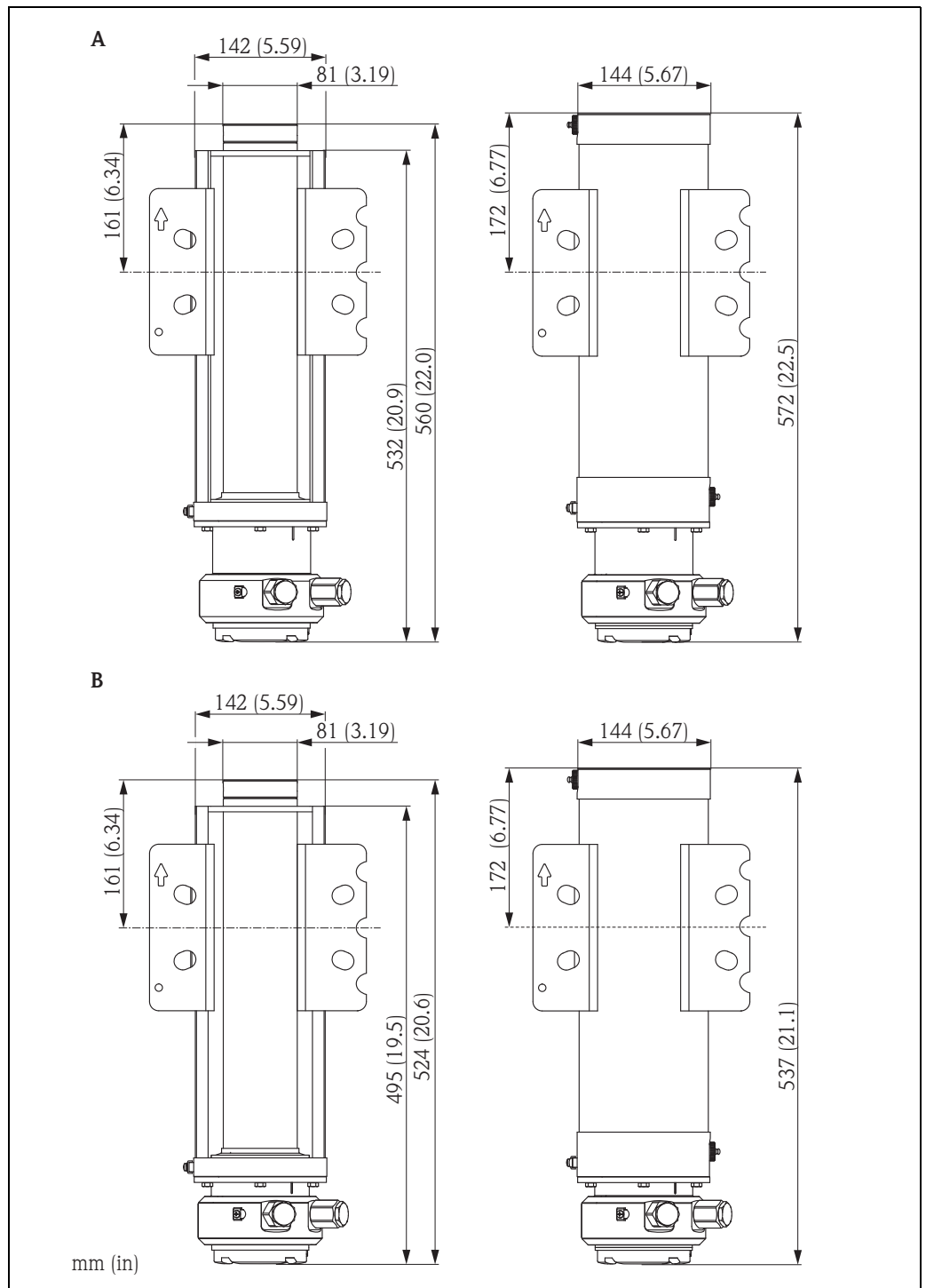

A0018530

A Ex de - version (left: without water jacket; right: with water jacket)
 B Ex d, Ex t, non-Ex - version (left: without water jacket; right: with water jacket)

Examples of mounting brackets (provided by customer)

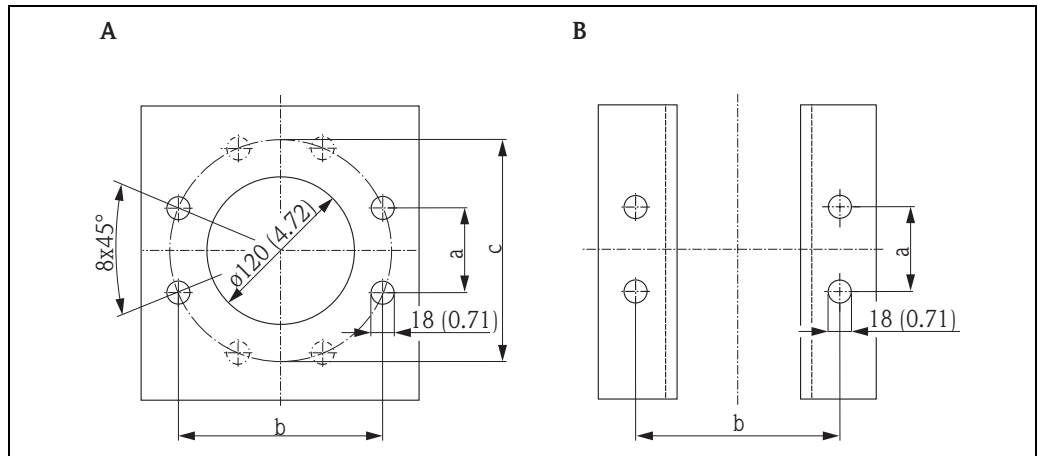

A0018531

A Mounting plate (Bolt circle according to DN 100 PN16 or ANSI 4" 150 psi)
 B L profile

Dimensions	DIN	ANSI
a	68,9 (2.71)	72,9 (2.87)
b	166,3 (6.55)	176,0 (6.93)
c	180,0 (7.09)	190,5 (7.5)

3.2.3 Installation

Safety instructions

▲ WARNING

Even when the source container is closed, it is possible that the modulator is in the control zone for radioactive radiation. In such instances, it must be cordoned off and made inaccessible.

For this reason, keep to the following order when mounting the modulator and source container:

1. Mount the Gamma Modulator FHG65 on the tank or pipe.
2. Perform the electrical connection of the Gamma Modulator.
3. If a water cooling jacket is available, connect the water supply.
4. Mount the source container on the modulator and cordon it off.

▲ CAUTION

All other work, such as servicing and replacing the modulator, may only be carried out by staff, whose exposure to radiation is monitored, in accordance with the existing handling permit and the existing license or the corresponding radiation protection laws. For details, please contact your radiation protection officer.

5. Switch on the modulator(s).
6. Measure and cordon off control zones.

▲ CAUTION

When measuring the local dose rate to determine the control zones, the modulator must be running and the measuring time selected must be long enough for a stable measured value to be present.

General installation conditions

- The Gamma Modulator FHG65 is mounted directly between the vessel and the mounting flange of the FQG61 or FQG62 source container.¹⁾

▲ CAUTION

It is absolutely essential to ensure the device is oriented correctly when mounting since the radiation exit channel is not located in the middle of the source container. The arrow on the mounting plate of the Gamma Modulator must point in the direction of the transporting lug of the source container. Measurement is not possible otherwise.

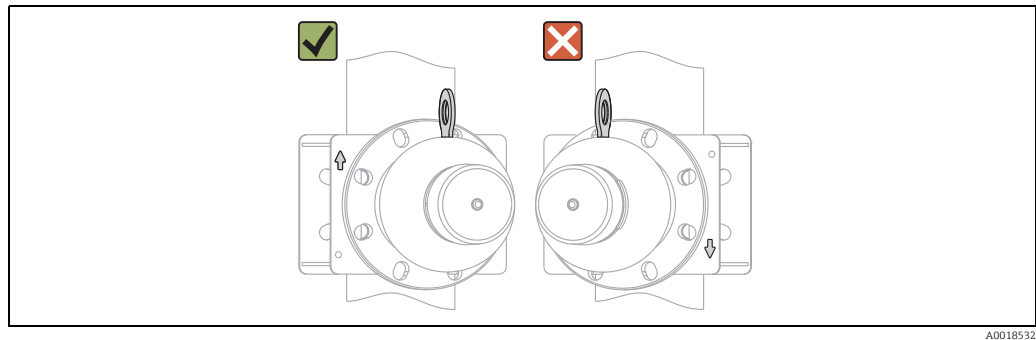

A0018532

- The source container together with the Gamma Modulator must be mounted as close as possible to the tank or measuring tube.
- The unit must be mounted on a low-vibration construction.
- Use at least 4 threaded bolts (M16);
Torque:
 - Steel: 210 Nm (154.88 lbf ft)
 - Stainless Steel: 144 Nm (106.20 lbf ft)
- When mounting, attention must be paid to the total weight consisting of the source container and Gamma Modulator FHG65. Ensure sufficient stability is guaranteed. Where necessary, an additional support must be provided.
- After mounting, the local dose rate in the vicinity of the source container and the Gamma Modulator must be measured. Any control zones must be cordoned off, see TI00435F/00/EN (FQG61/FQG62)
- Through to the use of the Modulator the effective useful horizontal radiation beam angle is reduced from 6° to 2°. → Please check if detector is completely covered by the radiation beam.

1) For applications with the QG2000 source container: please contact your local Endress+Hauser sales office.

Mounting multiple Gamma Modulators FHG65

If multiple Gamma Modulators FHG65 are used in a measuring point, they have to run synchronously. The Synchronizer FHG66 is used for this purpose.

NOTICE

The synchronization requires that all the Gamma Modulators FHG65 be aligned the same. A mark is provided at the top of the Gamma Modulator FHG65 to align the units. This mark must be aligned in the same way relative to the source container on all the participating Gamma Modulators.

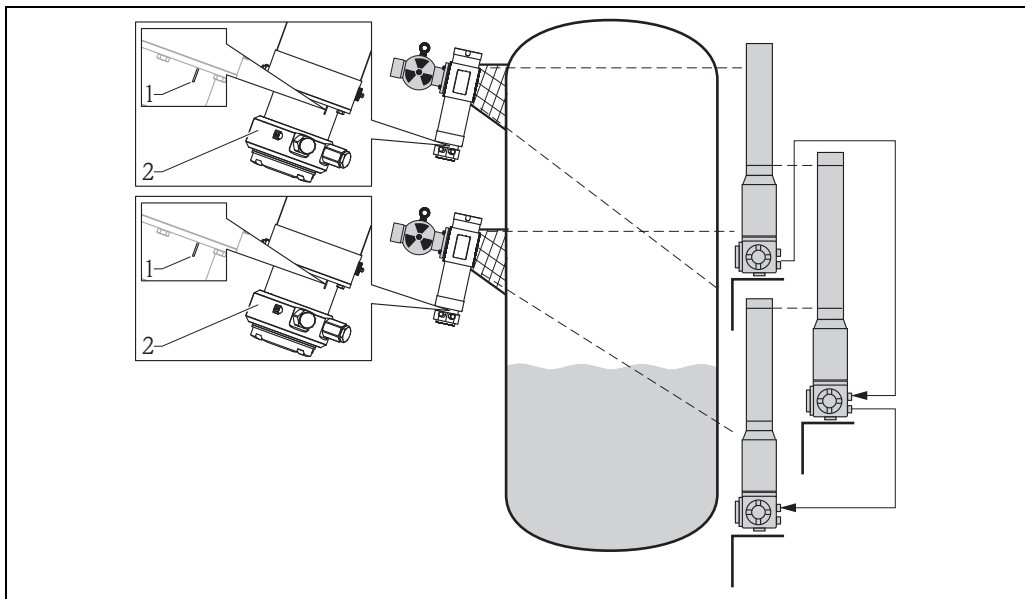

A0018533

- 1 Marking for aligning multiple Gamma Modulators
- 2 FHG65

Mounting at diagonally irradiated pipes

With diagonally irradiated pipes the clamping device FHG61 must be used for mounting. For details see Mounting Instructions KA00261F/00/A2.

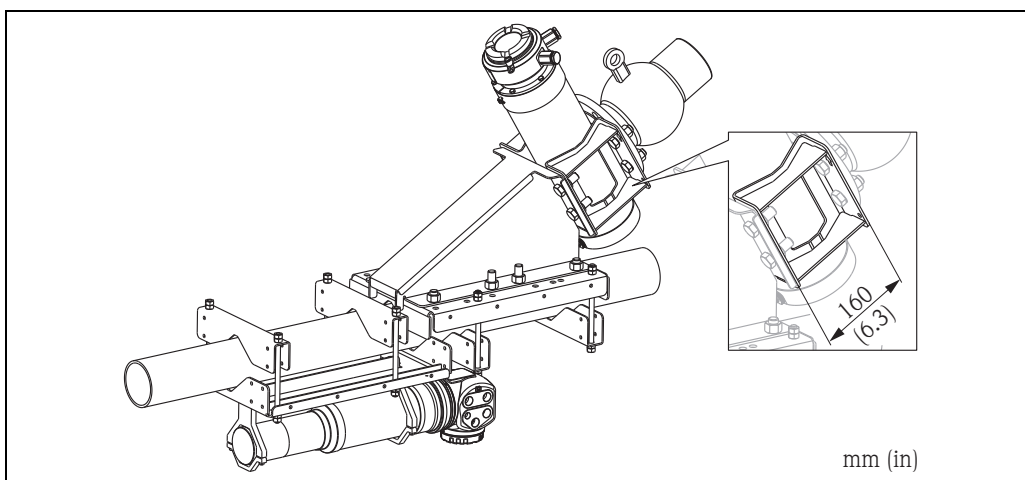

mm (in)

A0018534

Water cooling

The following applies to the Gamma Modulator FHG65 with water cooling:

- Material 316L and 304
- Water connection: 2 x G 1/4"A, DIN ISO 228
- Return temperature: max. 40 °C (104 °F); temperature monitoring recommended
- Water pressure: 4 to 6 bar (58 to 87 psi)
- Water flow rate: min. 60 l/h

▲ WARNING

Pressurized water cooling system!

- ▶ Do not open the cylinder screws (see figure below) when pressurized.

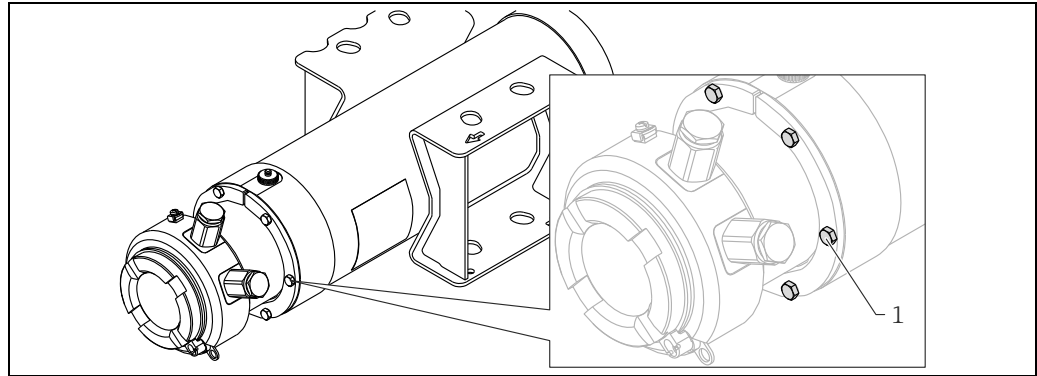

A0023367

1 Cylinder screws

▲ WARNING

Risk of injury by falling source container

- ▶ Before loosening the fastening screws of the modulator always dismantle the source container. Observe the safety instructions for radiation protection!

▲ CAUTION

Detector or cooling jacket can be damaged if the cooling water freezes.

- ▶ Empty cooling jacket or protect against freezing.

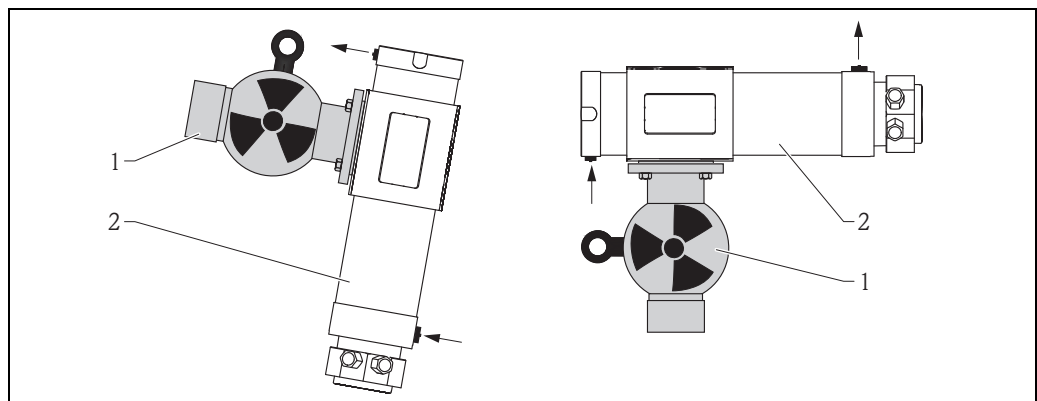

A0018535

1 FQG61, FQG62
2 FHG65

▲ CAUTION

The water must always be let in from the bottom to ensure that the water jacket is completely filled.

3.3 Post-installation check

- Is the Gamma Modulator FHG65 securely mounted to the vessel and to the source container?
- Does the arrow on the mounting plate of the Gamma Modulator point in the direction of the transporting lug of the FQG61 or FQG62 source container?
- Are the source container and the Gamma Modulator FHG65 securely mounted to a low-vibration console that can safely bear the total weight of the source container and the Gamma Modulator under all conditions that can be expected?
- Has the local dose rate been measured in the vicinity of the source container and Gamma Modulator FHG65 and have control zones (if present) been cordoned off?
- If multiple Gamma Modulators are deployed at one measuring point:
 - Are all the Gamma Modulators aligned the same (check marking)?
 - Are all the Gamma Modulators connected to the same Synchronizer (or to a cascaded Synchronizer)?
 - Is the Synchronizer configured correctly, i.e. is the green LED lit?

4 Wiring

4.1 Potential equalization

▲ CAUTION

Before wiring, connect the potential matching line to the external ground terminal (see next graphic). If a water cooling jacket is present, it must be separately connected to the potential matching line. For optimum electromagnetic compatibility, the potential matching line should be as short as possible and at least 2.5 mm^2 (13 AWG) in cross-section.

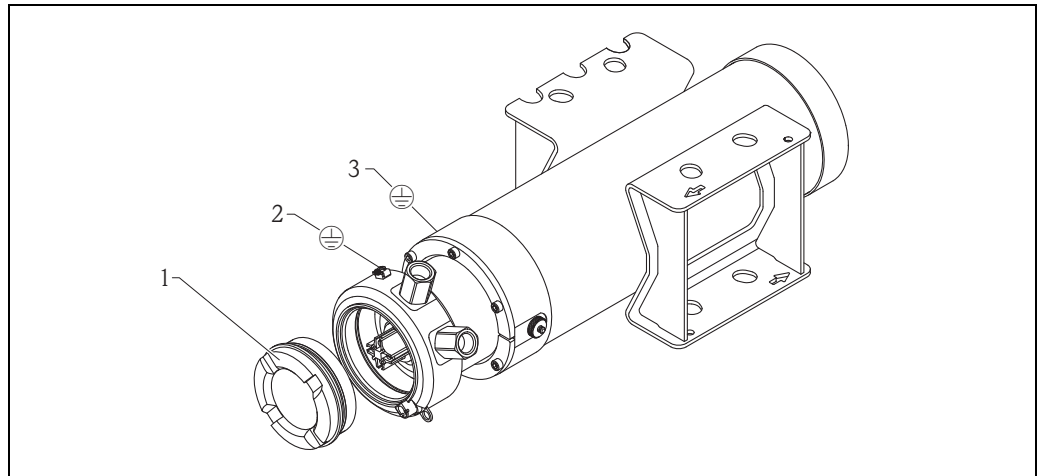

- 1 Cover of the connection compartment
2 Ground terminal of the modulator
3 Ground terminal of the water cooling jacket

A0018536

4.2 Cable entries

The Gamma Modulator FHG65 has two cable entries for:

- Supply voltage
- Synchronization connection

NOTICE

Connecting cables should be routed away from the housing from below to prevent moisture from penetrating the connection compartment. Otherwise, a drain loop should be provided or the Gamma Modulator should be fitted with a weather protection cover.

4.3 Terminal assignment

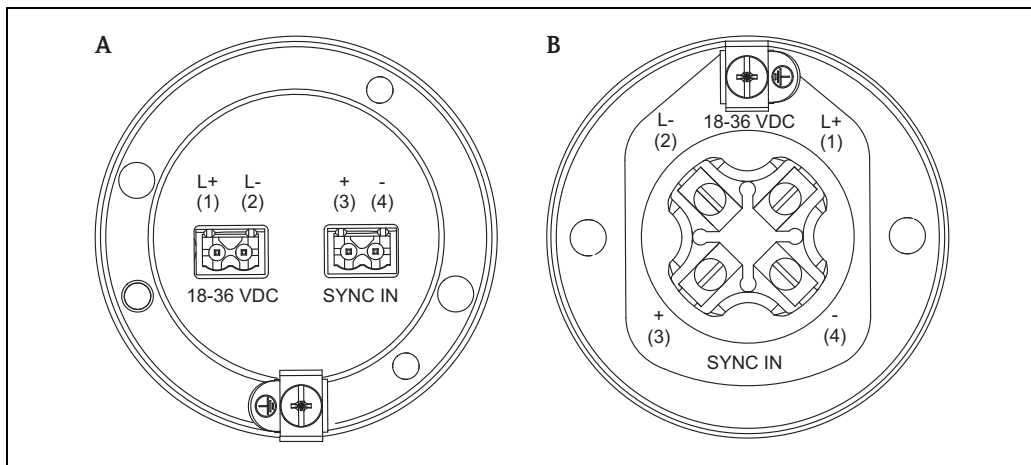

A0018538

A Ex d, Ex t, non-Ex - version
 B Ex de - version

Terminal	Name	Meaning
1	L+	Supply voltage; 18 to 36 VDC
2	L-	
3	SYNC +	Synchronization connection (to connect the Synchronizer FHG66) 12 VDC, 5 mA
4	SYNC -	

- Install a circuit breaker in the supply line.
- Use wires of $\geq 0.5 \text{ mm}^2$ (20 AWG) cross section.
- The flag of the ground connector has to be mounted in the direction indicated in the figure.

4.4 Alarm output

The Gamma Modulator FHG65 does not have an alarm output of its own. Errors are indicated in the following way:

- if a Synchronizer FHG66 is connected:
The error is reported via the synchronization terminals to the Synchronizer FHG66. The alarm relay of the FHG66 indicates the error.
- if no Synchronizer FHG66 is connected:
In the case of an error, the FHG65 switches its motor off. This reduces the current consumption to less than 30 mA, which can be detected and indicated by an external current monitoring device
(e.g. Dold IK9076.11, DC24V, < 0.1 A).
Can not be used in cascading mode.

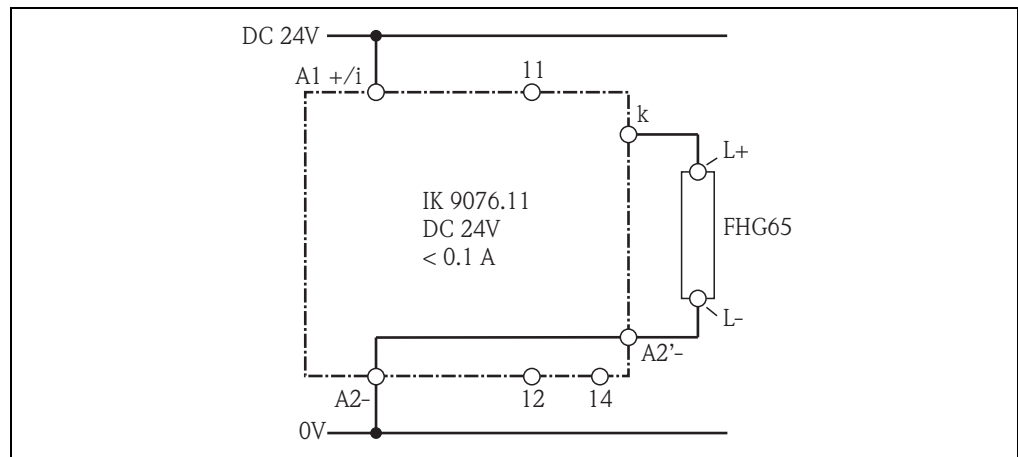

4.5 Post-connection check

- Are the terminals correctly assigned?
- Are the cable glands securely sealed?
- Is the cover of the connection compartment securely sealed?

5 Commissioning at the Gammapiot M FMG60

5.1 Configuring the beam type

When using the Gamma Modulator, the "Modulated" beam type must be configured in the Gammapiot M FMG60 (see also Operating Instructions on the Gammapiot M FMG60):

Onsite display	
Beam type	*02
Standard/cont.	
<input checked="" type="checkbox"/> Modulated	

This function is used to specify whether the radiation source used emits radiation continuously or whether it is modulated (for interference radiation suppression).

Options:

- Standard/continuous (permanent, continuous radiation)
- Modulated (modulated radiation source)

5.2 Recalibration

After installing the Gamma Modulator FHG65, the Gammapiot M FMG60 has to be recalibrated. The recalibration includes:

- Background calibration
- Empty or free calibration
- Full or covered calibration
- In the case of density and concentration measurements: one or multiple calibration points

Details on the calibration are provided in the following documents:

- BA00236F/00/EN (Gammapiot M FMG 60 with HART)
- BA00329F/00/EN (Gammapiot M FMG60 with PROFIBUS PA)
- BA00330F/00/EN (Gammapiot M FMG60 with FOUNDATION Fieldbus)
- SD00230F/00/EN (Gammapiot M FMG60 - Functional Safety Manual)

6 Maintenance and repair

6.1 Maintenance

No special maintenance work is required for the Gamma Modulator FHG65.

6.2 Cleaning

When cleaning the exterior, always use cleaning agents that do not corrode the surface of the housing and the seals.

Only dry cleaning is allowed for the wiring label in the terminal compartment.

6.3 Repair

The Endress+Hauser repair concept assumes that repairs to the Gamma Modulator FHG65 are performed by Endress+Hauser Service in Endress+Hauser workshops.

For more information contact the Service Department at Endress+Hauser.

6.4 Return

Returning devices

The measuring device must be returned if repairs or a factory calibration are required, or if the wrong measuring device has been ordered or delivered. According to legal regulations, Endress+Hauser, as an ISO-certified company, is required to follow certain procedures when handling returned products that are in contact with medium.

To ensure swift, safe and professional device returns, please read the return procedures and conditions on the Endress+Hauser website at: www.services.endress.com/return-material

6.5 Disposal

When disposing, separate and recycle the device components based on the materials.

6.6 Contact addresses at Endress+Hauser

Contact addresses can be found on our homepage: www.endress.com/worldwide.

If you have any questions, please contact your Endress+Hauser office.

7 Technical data

7.1 Additional technical data

For the technical data, please refer to the Technical Information TI00423F/00/EN.

7.2 Supplementary Documentation

The supplementary documentation can be found on our product pages on www.endress.com:

- Technical Information (TI00423F/00/EN)

8 Accessories: Synchronizer FHG66

8.1 Synchronizer FHG66

The synchronizer FHG66 is available as an accessory. Order code: 71060806

⚠ CAUTION

For the Synchronizer FHG66 observe the safety instructions in chapter "Safety instructions", → 4.

8.1.1 Use

Synchronization of multiple Gamma Modulators FHG65

In a measuring point with multiple radiation sources, a Gamma Modulator FHG65 has to be mounted on every source container. The Synchronizer FHG66 synchronizes the individual modulators to common mode. A Synchronizer FHG66 can synchronize up to three Gamma Modulators FHG65. (For more than 3 modulators refer to → 27)

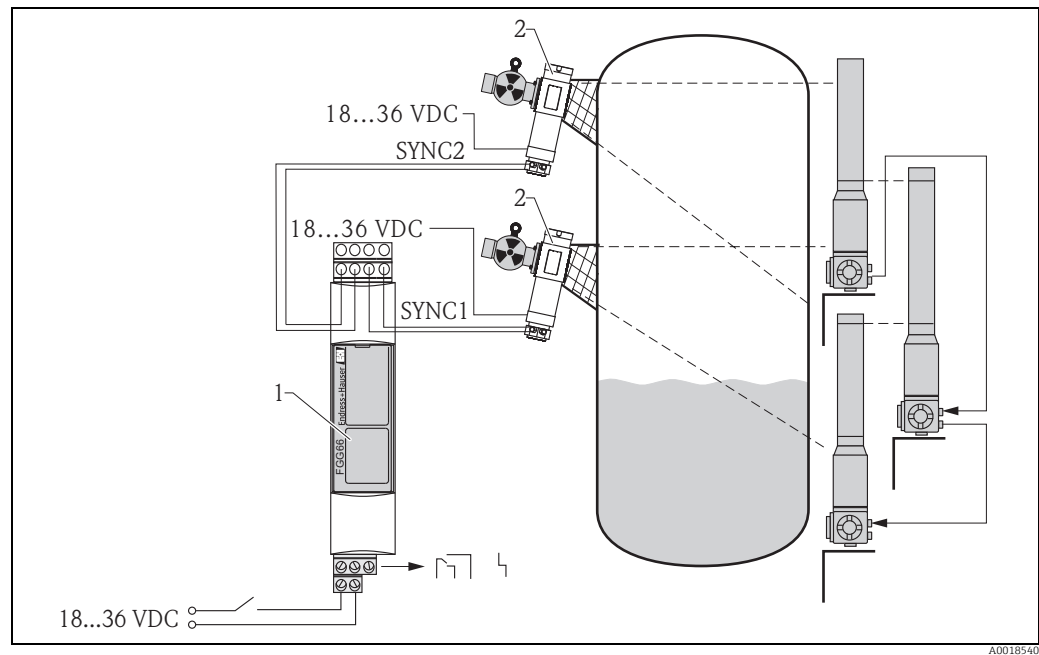

- 1 FHG66
2 FHG65

NOTICE

It is recommended to install the switch for the supply voltage in the proximity of the instrument and to mark it as a disconnecter for the instrument.

Cascading multiple Synchronizers FHG66

If more than three radiation sources are used, the synchronization chain can be extended by cascading, where another Synchronizer (3) is connected to one of the outputs of the Synchronizer (2) instead of a modulator. All connected Gamma Modulators then operate in common mode. By interconnecting this cascading function, any number of modulators can be synchronized with one another.

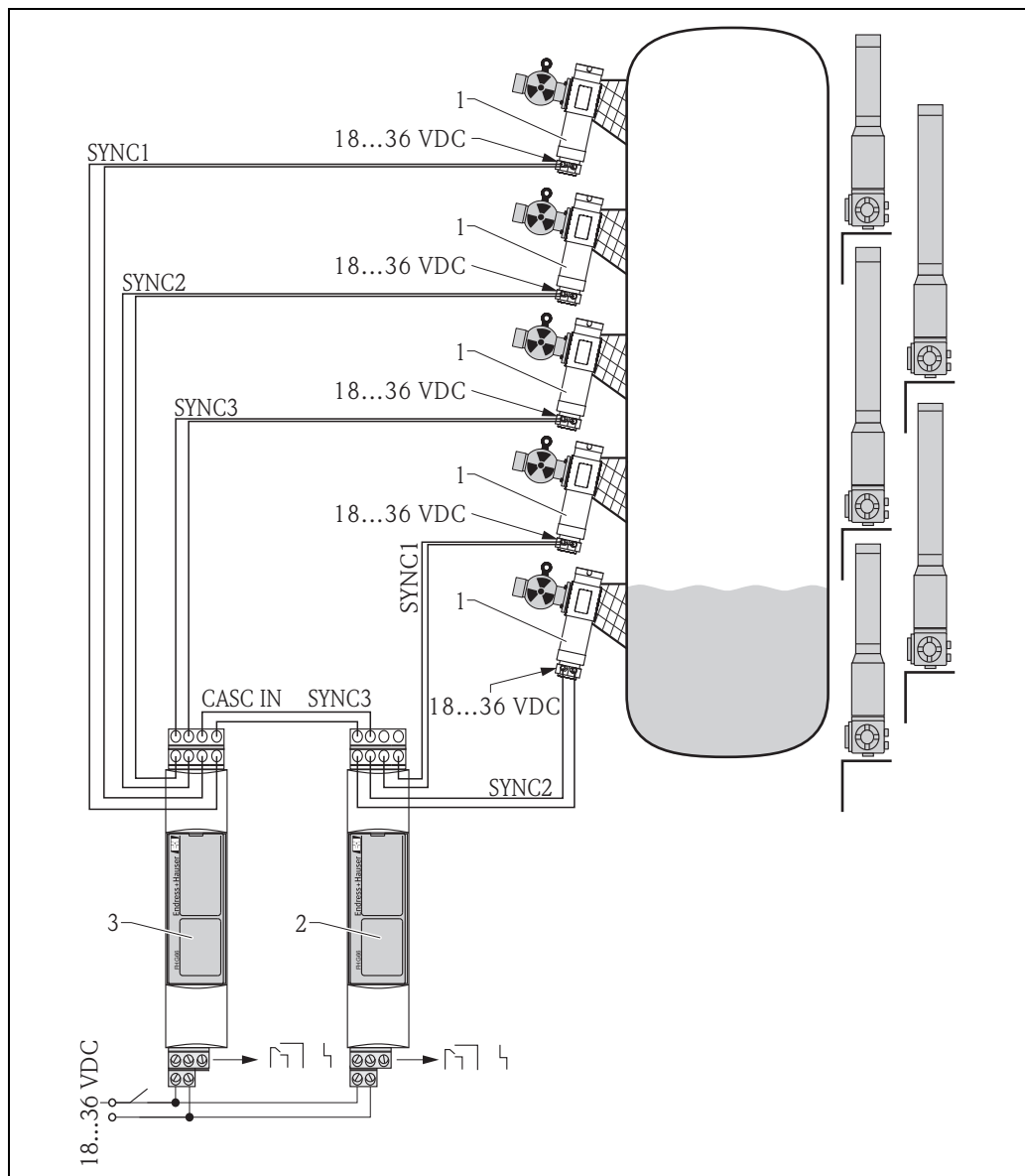

A0018541

- 1 FHG65
- 2 Primary Synchronizer
- 3 Cascaded Synchronizer

8.1.2 FHG66 technical data

Input	
Cascading input	<ul style="list-style-type: none"> ▪ Galvanically isolated from power supply and output ▪ Connecting cable: twin-core; shielding not required (apart from in the event of strong electromagnetic interference) ▪ Cable requirements: <ul style="list-style-type: none"> – Max. capacitance: 120 nF – Max. resistance 1000 Ω – Max. inductance: 0.65 mH – Cable: not shielded/not twisted ▪ Signal transmission: closed current loop with 0 to 5 mA, max. 12 V
Output	
Alarm relay	<ul style="list-style-type: none"> ▪ Type: floating changeover contact ▪ Switching delay: 0 to 3 s ▪ Switching capacity: <ul style="list-style-type: none"> – U~ maximum 250V – I~ maximum 2 A – P~ maximum 500 VA at $\cos\varphi \geq 0.7$ – U- maximum 40 V – I- maximum 2 A – P- maximum 80 W ▪ Operating life: min. 10^5 switching cycles with maximum contact load ▪ Function indicator: light emitting diodes for operation, faults and error assignment; device detects and reports errors in the configuration and in the connected devices ▪ Overvoltage category: II ▪ Protection class: 2 (double/reinforced isolation)
Signal on alarm	<ul style="list-style-type: none"> ▪ Fault indicated by red LED ▪ Fault assigned by yellow LEDs ▪ Alarm relay deenergized
Power supply	
Supply voltage	18 to 36 VDC (power supply with safe isolation required)
Power consumption	≤ 1 W
Overvoltage category	II
Protection class	2
Contamination level	2
Environment	
Ambient temperature range	<ul style="list-style-type: none"> ▪ Mounted individually: -20 to +60 °C (-4 to +140 °F) ▪ Mounted in a row without lateral spacing: -20 to +50 °C (-4 to +122 °F) ▪ When installed in protective housing: -20 to +40 °C (-4 to +104 °F)
Storage temperature	-20 to +85 °C (-4 to +185 °F) (preferably 20 °C (-4 °F))
Climate and mechanical application class	<ul style="list-style-type: none"> ▪ 3C3 in accordance with DIN EN 60721-3-3 ▪ 3M2 in accordance with DIN EN 60721-3-3
Degree of protection	IP20 Mechanical degree of protection IK06 (1J) according to IEC 62262
Electromagnetic compatibility (EMC)	<ul style="list-style-type: none"> ▪ Interference emission to EN61326, class B equipment ▪ Interference immunity to EN61326, Appendix A (Industrial) and NAMUR Recommendation NE 21
Mechanical construction	
Weight	Approx. 150 g (5.291 oz)

Input	
Material	<p>Housing</p> <ul style="list-style-type: none"> Polycarbonate Color: light-gray, RAL 7035 <p>Front cover</p> <ul style="list-style-type: none"> Polyamide PA6 Color: film, blue NCS1040-B206 <p>Fixing slide (to secure to top-hat rail)</p> <ul style="list-style-type: none"> Polyamide PA6 Color: light-gray, RAL 7035

8.1.3 FHG66 identification

Nameplate

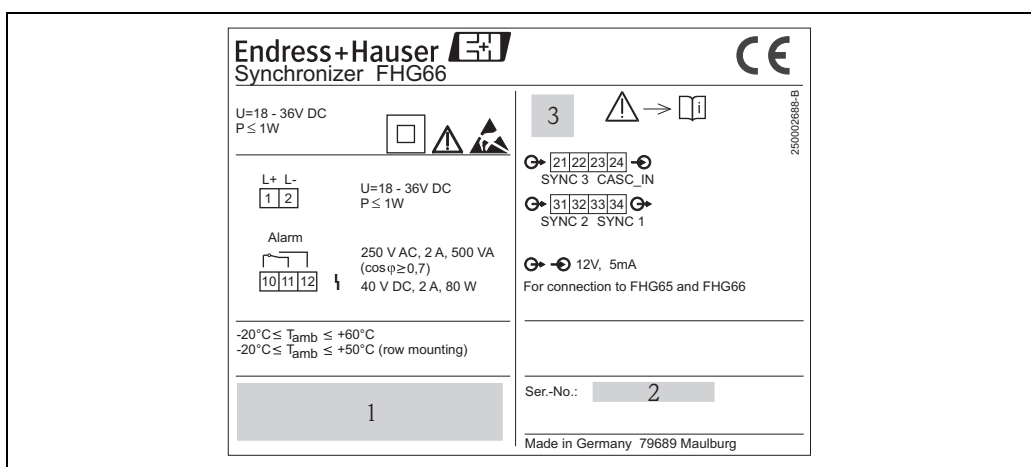

A0018542

- 1 Barcode of the serial number
- 2 Serial number
- 3 Certificate symbol (for certified devices)

8.1.4 FHG66 mounting

Dimensions

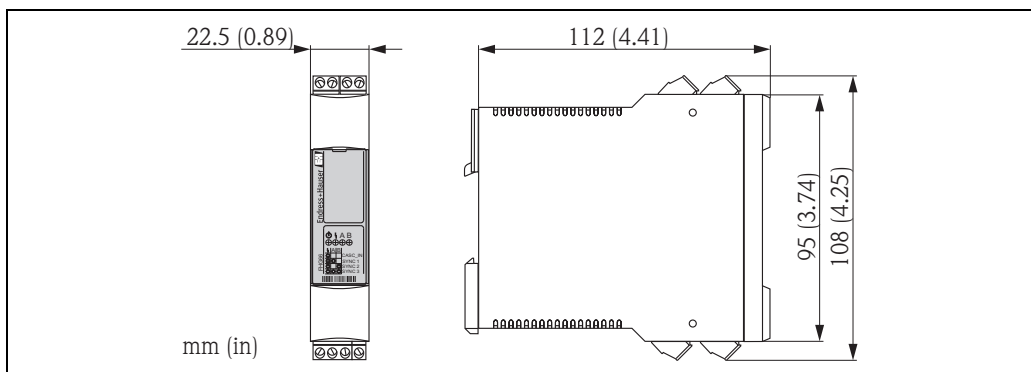

A0018543

Installation conditions

The Synchronizer FHG66 must be housed in a cabinet outside the hazardous area and protected against mechanical influences. If mounting outdoors, a protective housing (min. IP65) must be used.

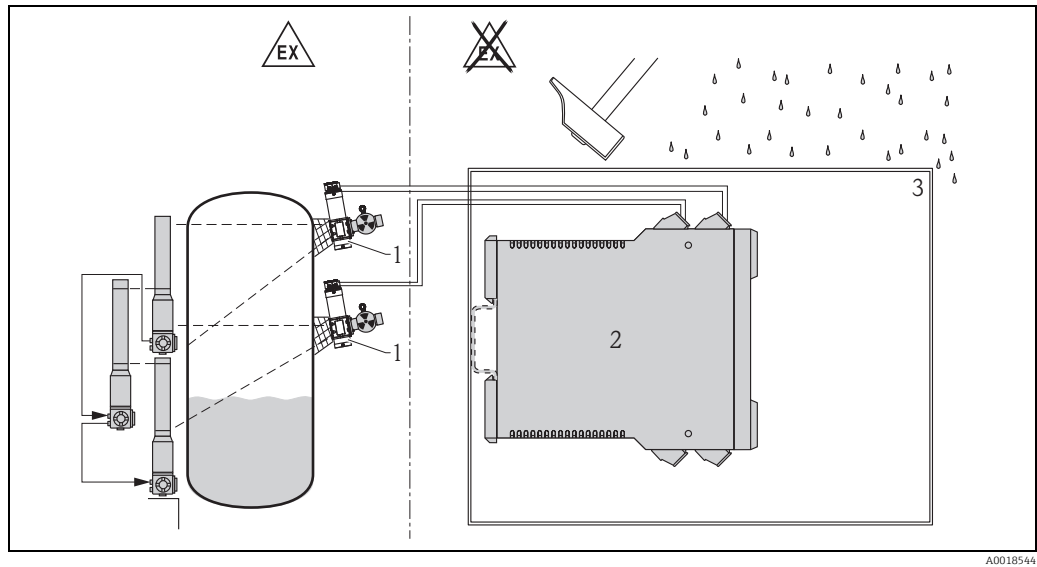

A0018544

⚠ CAUTION

Observe the following conditions:

- ▶ Mechanical degree of protection: see "FHG66 technical data", → 28.
- ▶ The ventilation slots of the housing must not be blocked.

Installation instructions

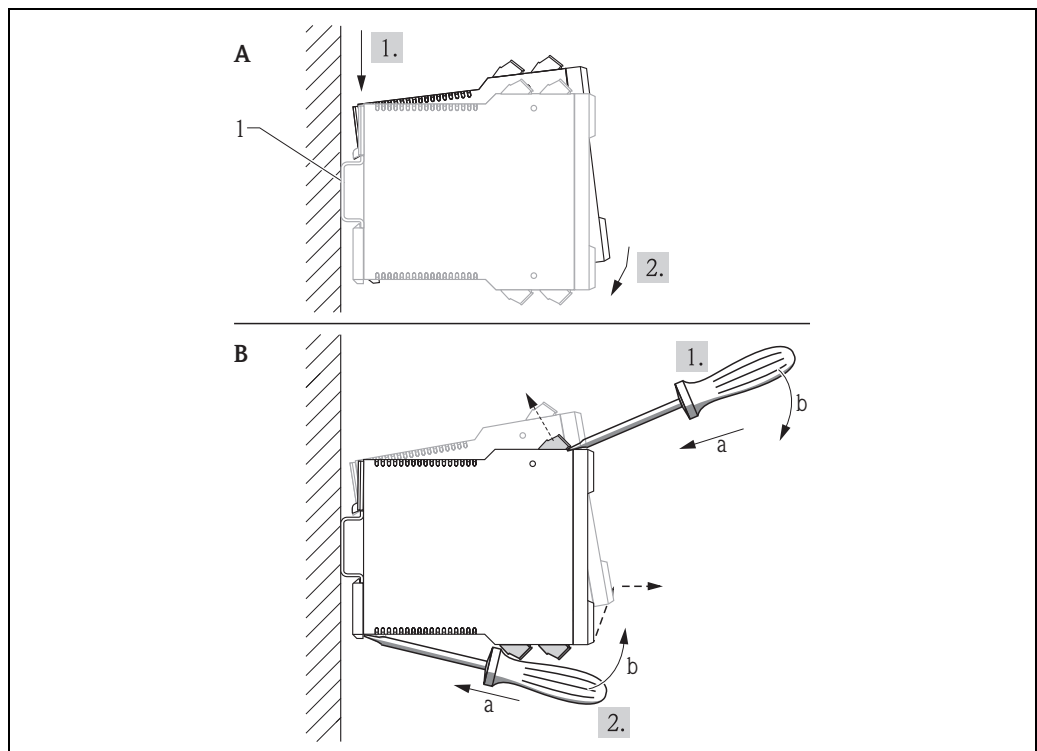

A0018545

- A Mounting on top-hat rail
 B Disassembly (1. Remove terminal blocks; 2. Remove device)

8.1.5 FHG66 wiring

Terminals

Pluggable screw terminals. Wire cross-section:

- 1.0 to 2.5 mm² (17 to 13 AWG) for supply voltage and relay
- 0.5 to 2.5 mm² (20 to 13 AWG) for signal line

⚠ CAUTION

The terminals may only be replaced by identical types.

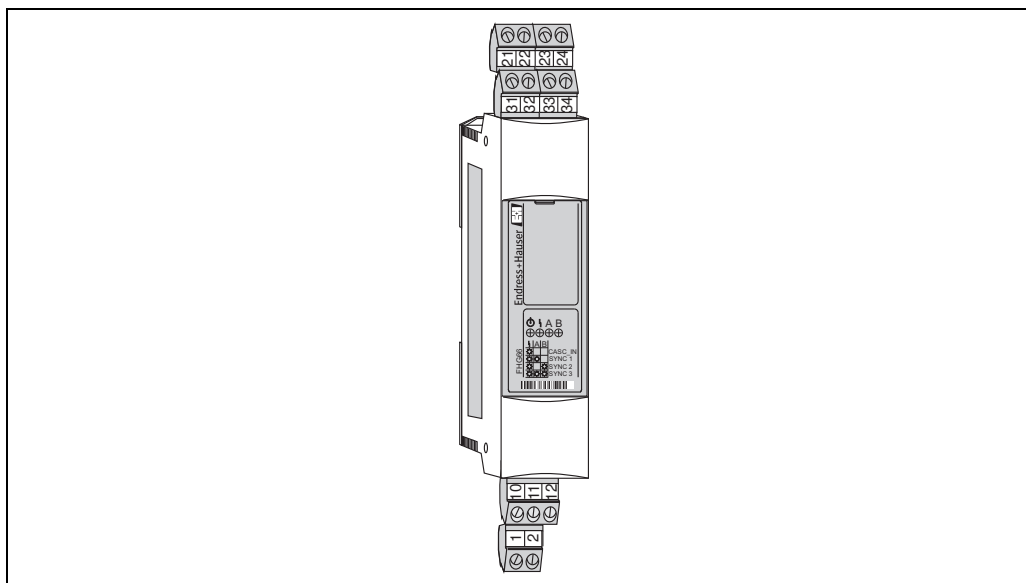

A0018546

Terminal assignment

Terminal	Meaning	Remarks
Power supply		
1	L+	18 to 36 VDC Power supply with safe isolation required
2	L-	
Alarm relay		
10	Changeover	
11	NC contact	Is connected to contact 10 if an error is present
12	NO contact	Is connected to contact 10 during error-free operation
Synchronization outputs		
33/34	Synchronization output 1	Synchronization signal: 12 V/5 mA The following can be connected: <ul style="list-style-type: none"> ■ a Gamma Modulator FHG65 ■ an additional Synchronizer FHG66 (for cascading) Polarity is random.
31/32	Synchronization output 2	
21/22	Synchronization output 3	
Cascading input		
23/24	Cascading input	For connecting an additional, upstream Synchronizer FHG66. All the Gamma Modulators connected to the Synchronizers then run in common mode. Cascading signal: 12 V/5 mA

8.1.6 FHG66 display elements

Indication of the operating state; error messages

Visible when the front panel is closed.

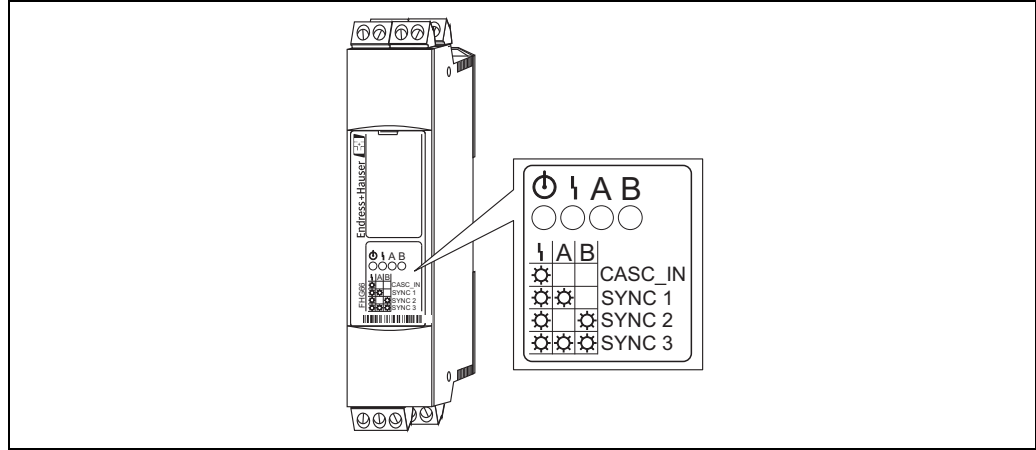

A0018547

LED	Color	Meaning
⏻	Green	Operational Is lit as soon as the supply voltage is switched on.
⚡	Red	Error Is lit if an error is present at one of the synchronization outputs or the cascading input.
A,B	Yellow	Error identifier Indicates the synchronization output where the error is present: <ul style="list-style-type: none"> ▪ A: Error at SYNC 1 ▪ B: Error at SYNC 2 ▪ A and B: Error at SYNC 3 ▪ A and B off, but red LED lit: Error at the cascading input (CASC_IN)

8.1.7 FHG66 operating elements

DIP switches

Behind the swing-back front panel.

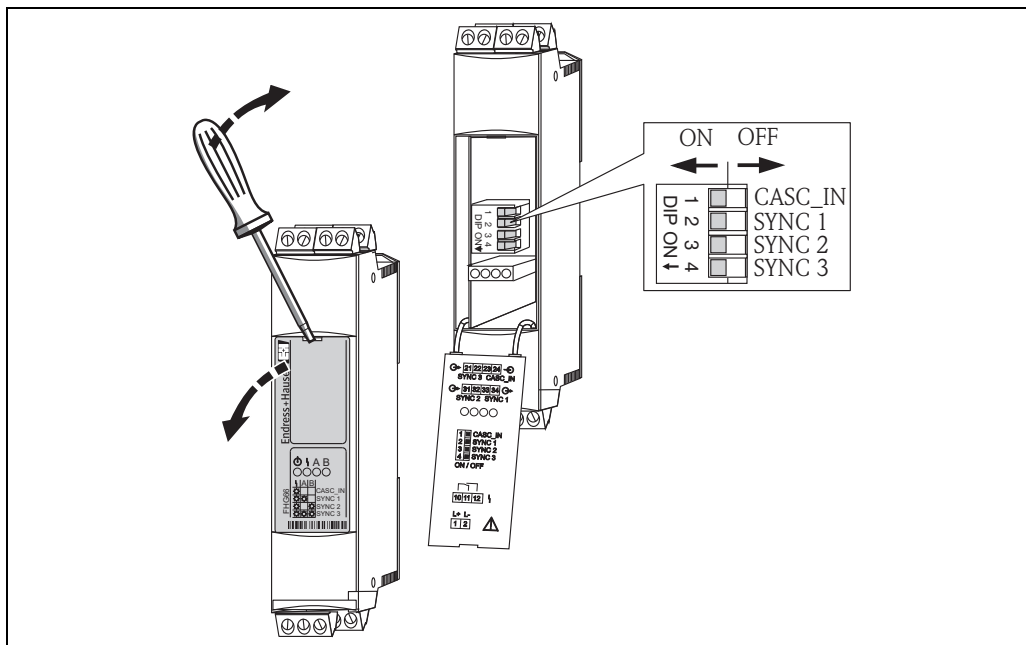

A0018548

The DIP switches are used to switch the synchronization outputs and the cascading input on and off in accordance with the diagram above.

NOTICE

Outputs which are not used must be switced "OFF".

DIP switches	Input/output
1	Cascading input (terminals 23/24)
2	Synchronization output 1 (terminals 33/34)
3	Synchronization output 2 (terminals 31/32)
4	Synchronization output 3 (terminals 21/22)

8.1.8 Cleaning the FHG66

Only dry cleaning is allowed for the front cover of the Synchronisator FHG66.

8.1.9 Maintenance FHG66

No special maintenance work is required for the Synchronizer FHG66.



71252996

www.addresses.endress.com
