

Operating Instructions

Turbimax CUS51D

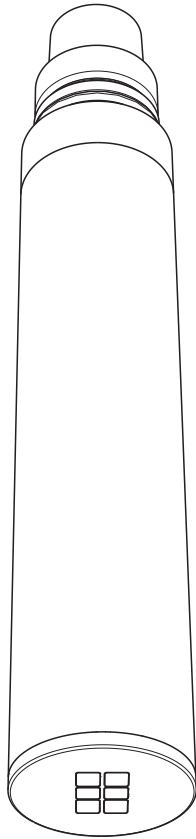



Sensor for turbidity and solids content



About this document

Notes on safety icons

The structure, signal words and safety colors of the signs comply with the specifications of ANSI Z535.6 ("Product safety information in product manuals, instructions and other collateral materials").

Safety message structure	Meaning
 DANGER Cause (/consequences) Consequences if safety message is not heeded ▶ Corrective action	This symbol alerts you to a dangerous situation. Failure to avoid the situation will result in a fatal or serious injury.
 WARNING Cause (/consequences) Consequences if safety message is not heeded ▶ Corrective action	This symbol alerts you to a dangerous situation. Failure to avoid the situation can result in a fatal or serious injury.
 CAUTION Cause (/consequences) Consequences if safety message is not heeded ▶ Corrective action	This symbol alerts you to a dangerous situation. Failure to avoid this situation can result in minor or medium injury.
 NOTICE Cause/situation Consequences if safety message is not heeded ▶ Action/note	This symbol alerts you to situations that can result in damage to property and equipment.

Symbols





-  Additional information, tips
-  Permitted or recommended
-  Forbidden or not recommended

Table of contents

1	Safety instructions	4	10	Technical Data	35
1.1	Requirements for the personnel	4	10.1	Input	35
1.2	Designated use	4	10.2	Performance characteristics	36
1.3	Workplace safety	4	10.3	Environment	37
1.4	Operational safety	4	10.4	Process	37
1.5	Product safety	5	10.5	Mechanical construction	38
2	Incoming acceptance and product identification	6		Index	39
2.1	Incoming acceptance	6			
2.2	Product identification	6			
2.3	Scope of delivery	6			
2.4	Certificates and approvals	6			
3	Installation	7			
3.1	Dimensions	7			
3.2	Installation instructions	8			
3.3	Installation examples	10			
3.4	Post-installation check	14			
4	Wiring	15			
4.1	Connecting to the transmitter	15			
4.2	Post-connection check	15			
5	Device description	16			
5.1	Sensor design	16			
5.2	Measuring principle	16			
5.3	Measuring methods	19			
5.4	Application	21			
5.5	Calibration	23			
5.6	Stability criterion	29			
5.7	Cyclic cleaning	29			
6	Diagnostics and troubleshooting	30			
7	Maintenance	31			
7.1	Cleaning the sensor	31			
8	Repair	32			
8.1	Return	32			
8.2	Disposal	32			
9	Accessories	33			
9.1	Assemblies	33			
9.2	Holder	33			
9.3	Compressed air cleaning	34			
9.4	Transmitter	34			

1 Safety instructions

1.1 Requirements for the personnel

- ▶ Installation, commissioning, operation and maintenance of the measuring system must only be carried out by trained technical personnel.
 - ▶ The technical personnel must be authorized by the plant operator to carry out the specified activities.
 - ▶ The electrical connection may only be performed by an electrical technician.
 - ▶ The technical personnel must have read and understood these Operating Instructions and must follow the instructions they contain.
 - ▶ Measuring point faults may only be rectified by authorized and specially trained personnel.
-  Repairs not described in the enclosed Operating Instructions may only be carried out directly at the manufacturer's or by the service organization.

1.2 Designated use

CUS51D is a sensor designed to measure the turbidity and solids content of water and wastewater.

The sensor is particularly suited for use in the following applications:

- Turbidity measurement in the outlet
- Suspended solids in the activated sludge basin and in the recirculation
- Suspended solids in the sludge treatment
- Filterable solids in the outlet

Any other use than the one described here compromises the safety of persons and the entire measuring system and is not permitted.

The manufacturer is not liable for damage caused by improper or non-designated use.

1.3 Workplace safety

As the user, you are responsible for complying with the following safety conditions:

- Regulations for explosion protection
- Installation instructions
- Local standards and regulations

Electromagnetic compatibility

With regard to electromagnetic compatibility, this device has been tested in accordance with the applicable European standards for industrial applications.

The electromagnetic compatibility indicated only applies to a device that has been connected in accordance with the instructions in these Operating Instructions.

1.4 Operational safety

- ▶ Before commissioning the entire measuring point, make sure all the connections are correct. Ensure that electrical cables and hose connections are not damaged.
- ▶ Do not operate damaged products, and safeguard them to ensure that they are not operated inadvertently. Mark the damaged product as defective.
- ▶ If faults cannot be rectified, the products must be taken out of service and secured against unintentional commissioning.

1.5 Product safety

The product is designed to meet state-of-the-art safety requirements, has been tested and left the factory in a condition in which it is safe to operate. Relevant regulations and European standards have been observed.

2 Incoming acceptance and product identification

2.1 Incoming acceptance

- ▶ Make sure the packaging is undamaged!
- ▶ Inform the supplier about any damage to the packaging.
Keep the damaged packaging until the matter has been settled.
- ▶ Make sure the contents are undamaged!
- ▶ Inform the supplier about damage to the contents. Keep the damaged products until the matter has been settled.
- ▶ Check that the order is complete and agrees with your shipping documents.
- ▶ The packaging material used to store or to transport the product must provide shock protection and humidity protection. The original packaging offers the best protection. Also, keep to the approved ambient conditions (see "Technical data").
- ▶ If you have any questions, please contact your supplier or your local sales center.

2.2 Product identification

2.2.1 Nameplate

The nameplate contains the following information:

- Manufacturer data
- Order code
- Extended order code
- Serial number
- Operating conditions
- Safety icons

Compare the order code on the nameplate with your order.

2.2.2 Identifying the product

The order code and serial number of your device can be found in the following locations:

- On the nameplate
- On the front page of these Operating Instructions
- In the delivery papers

 To find out the version of your device, enter the order code indicated on the nameplate in the search screen at the following address:

www.products.endress.com/order-ident

2.3 Scope of delivery

The scope of delivery comprises:

- 1 sensor Turbimax CUS51D in the ordered version
- 1 Operating Instructions BA00461C/07/EN

If you have any questions, please contact your supplier or your local sales center.

2.4 Certificates and approvals

Declaration of conformity

The product meets the requirements of the harmonized European standards. It thus complies with the legal requirements of the EC directives.

The manufacturer confirms successful testing of the product by affixing the **CE** symbol.

3 Installation

3.1 Dimensions

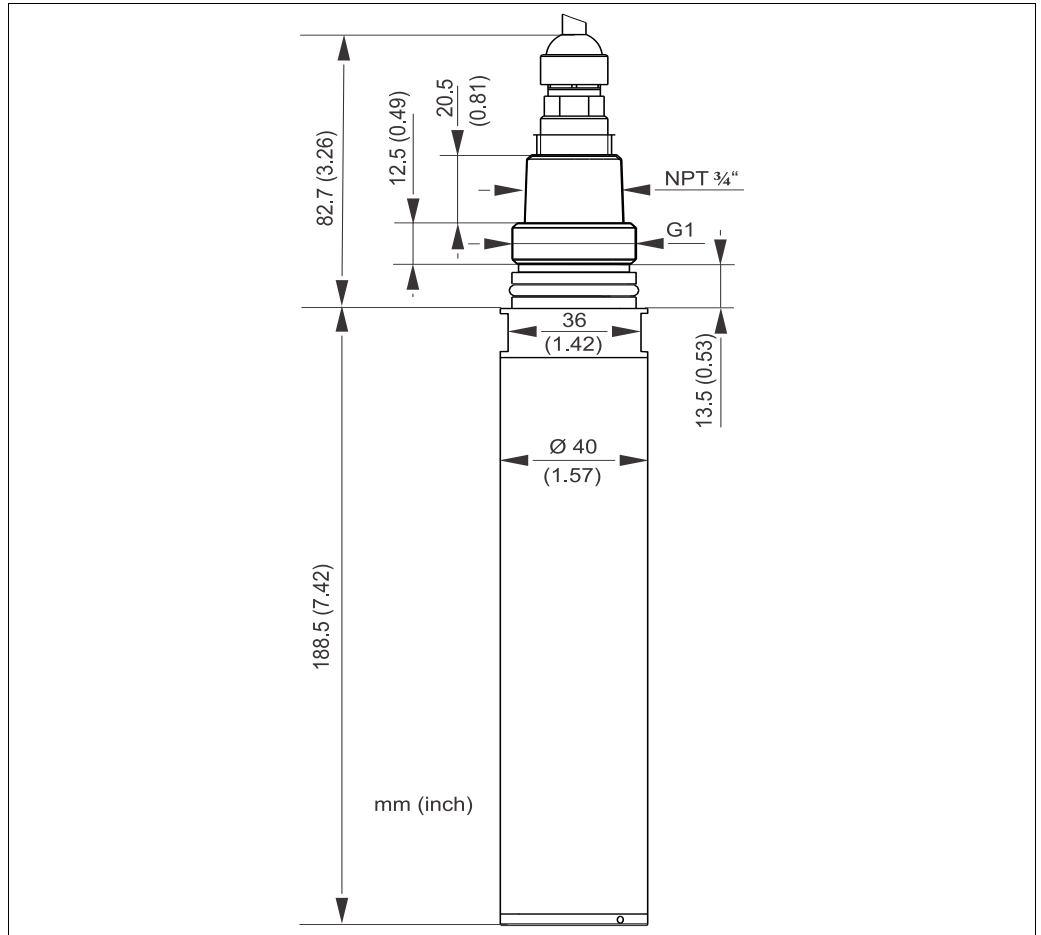

Fig. 1: Dimensions

See the "Accessories" section for the dimensions of the cleaning unit

3.2 Installation instructions

3.2.1 Measuring system

A complete measuring system comprises:

- Turbidity sensor Turbimax CUS51D
- Transmitter Liquiline
- Assembly:
 - Assembly Flexdip CYA112 and holder system Flexdip CYH112 or
 - Retractable assembly , e.g. Cleanfit CUA451

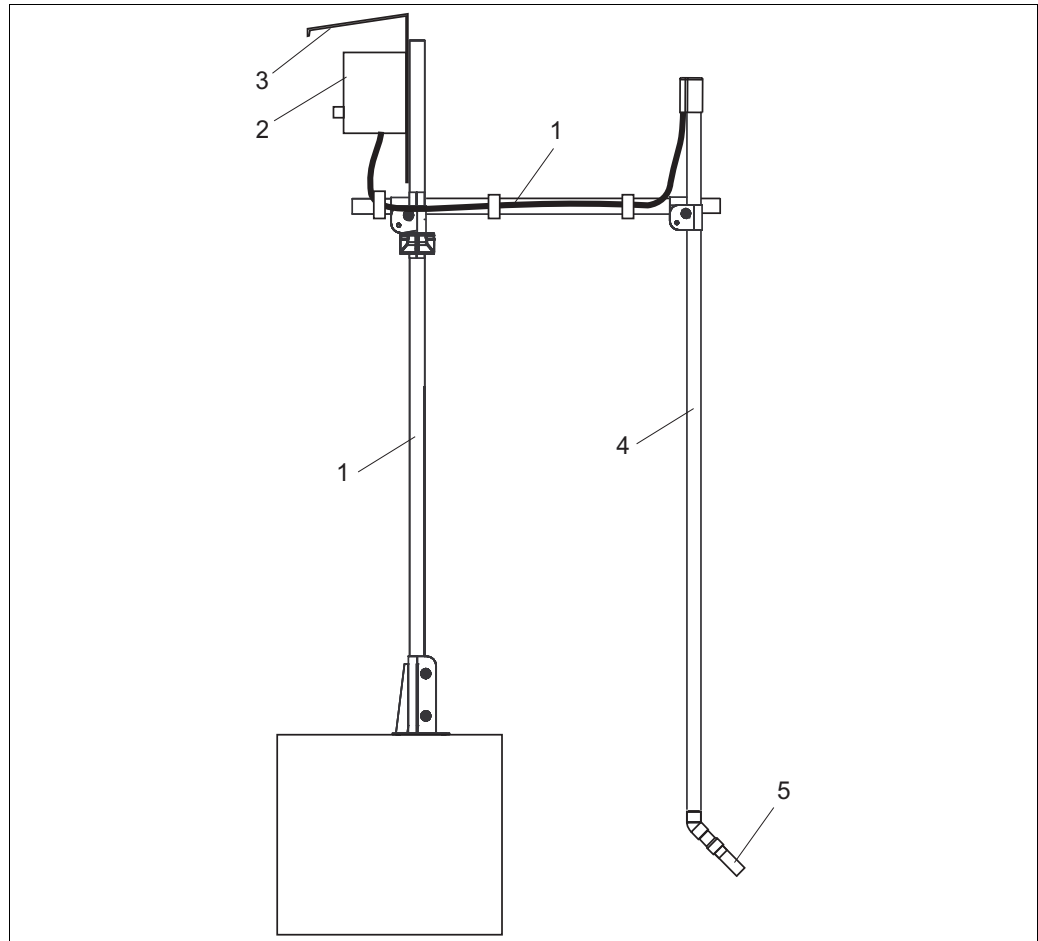

a0012965

Fig. 2: Measuring system with immersion assembly (example)

- | | | | |
|---|------------------------------|---|----------------------------------|
| 1 | Holder system Flexdip CYH112 | 4 | Assembly Flexdip CYA112 |
| 2 | Transmitter Liquiline | 5 | Turbidity sensor Turbimax CUS51D |
| 3 | Weather protection roof | | |

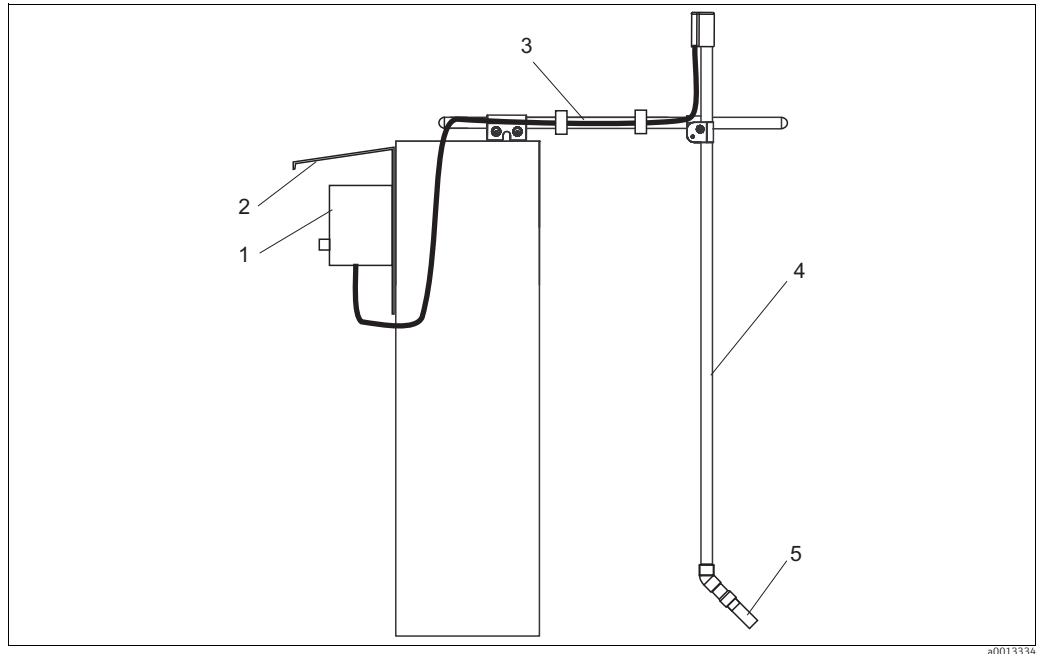

Fig. 3: Measuring system with immersion assembly (example)

- | | | | |
|---|------------------------------|---|----------------------------------|
| 1 | Transmitter Liquiline | 4 | Assembly Flexdip CYA112 |
| 2 | Weather protection roof | 5 | Turbidity sensor Turbimax CUS51D |
| 3 | Holder system Flexdip CYH112 | | |

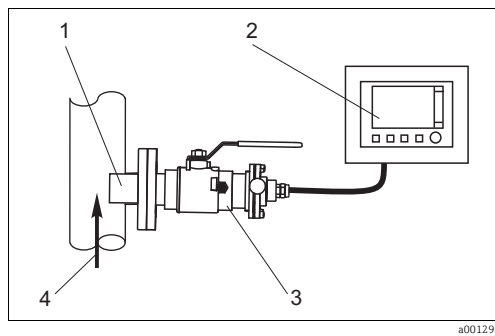

Fig. 4: Measuring system with retractable assembly (example)

- | | |
|---|--------------------------------------|
| 1 | Turbidity sensor Turbimax CUS51D |
| 2 | Transmitter Liquiline |
| 3 | Retractable assembly Cleanfit CUA451 |
| 4 | Flow direction |

3.3 Installation examples

3.3.1 Immersion operation

Fixed installation with wastewater assembly

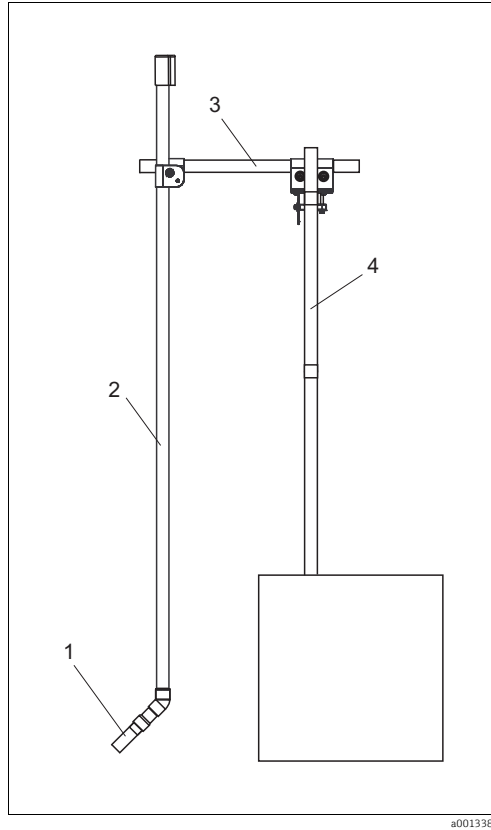

Fig. 5: Installation secured on railing

- 1 Turbidity sensor Turbimax CUS51D
- 2 Flexdip CYA112 wastewater assembly
- 3 Flexdip CYH112 holder
- 4 Railing

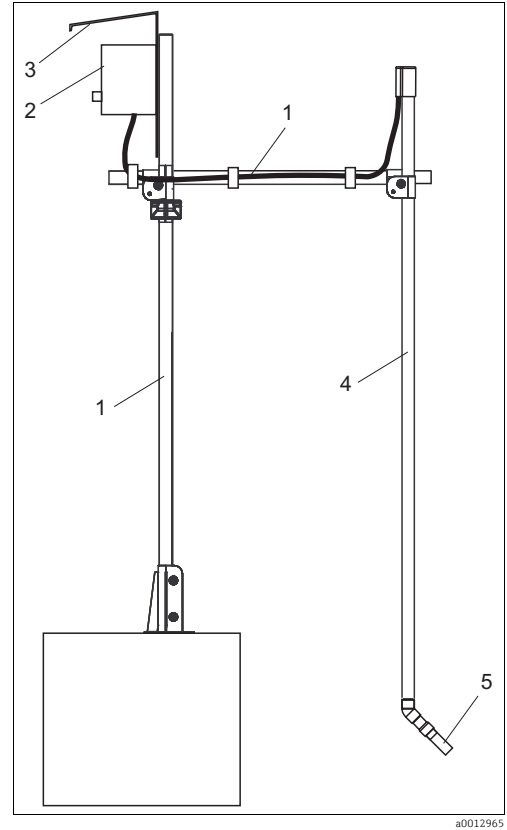
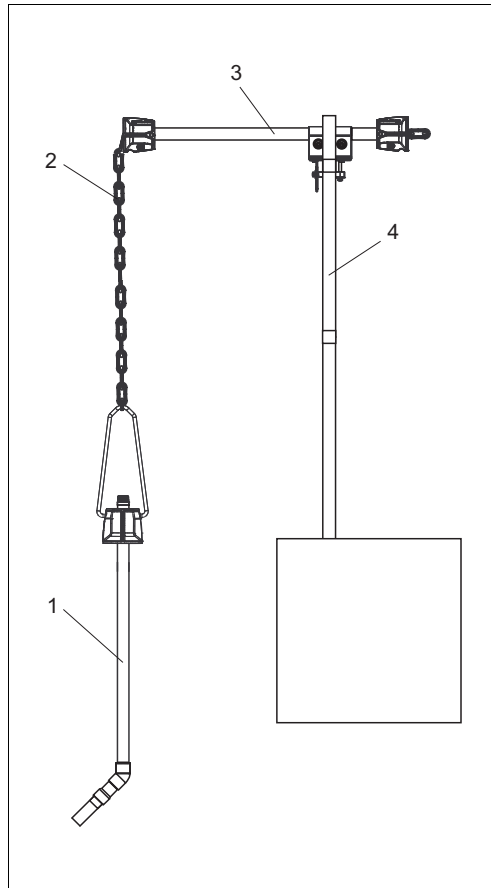

Fig. 6: Installation with upright post

- 1 Flexdip CYH112 holder
- 2 Multichannel transmitter Liquiline CM44x
- 3 Weather protection cover
- 4 Flexdip CYA112 wastewater assembly
- 5 Turbidity sensor Turbimax CUS51D

This type of installation is particularly suitable for strong or turbulent flow (>0.5 m/s (1.6 ft/ s)) in the basin or channels.

Installation with chain retainer



a0013384

Fig. 7: Chain retainer on railing

- 1 Flexdip CYA112 wastewater assembly with Turbimax CUS51D turbidity sensor
- 2 Chain
- 3 Flexdip CYH112 holder
- 4 Railing

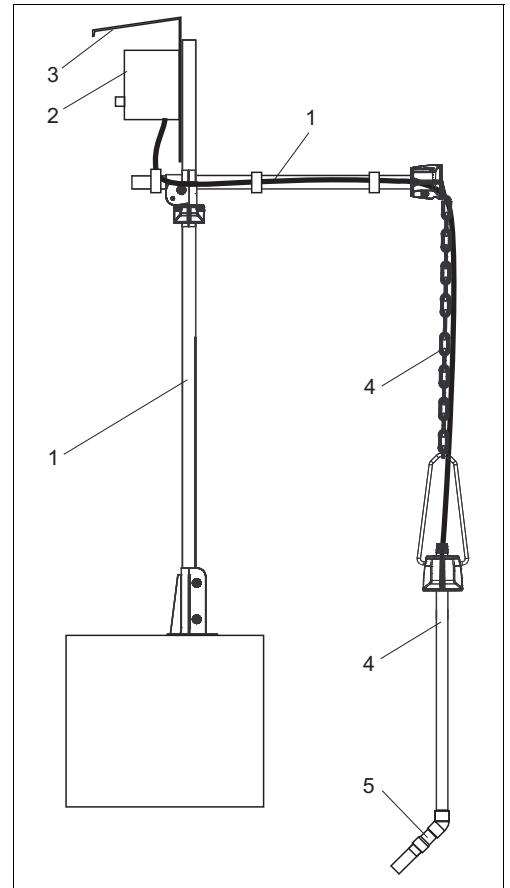

a0013386

Fig. 8: Chain retainer on upright post

- 1 Flexdip CYH112 holder
- 2 Multichannel transmitter Liquiline CM44x
- 3 Weather protection cover
- 4 Flexdip CYA112 wastewater assembly
- 5 Turbidity sensor Turbimax CUS51D

The chain retainer is particularly suitable for applications that require a sufficient distance between the mounting location and the edge of the aeration basin. As the assembly is freely suspended, any vibration of the upright post is practically ruled out. The swinging movement of the chain retainer enhances the self-cleaning effect of the optical window.

Cleaning unit

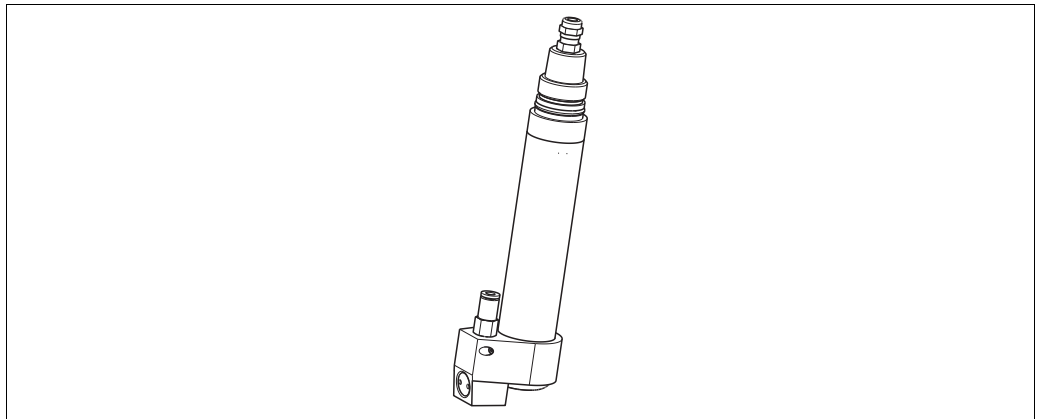



Fig. 9: Turbimax CUS5 1D sensor with cleaning unit

The cleaning unit is particularly suitable for clear water and media containing fats/oils that tend to cause heavy buildup.

Mount the cleaning unit as follows:

1. Fit the cleaning unit onto the sensor as far as it will go.
2. Locate the two LEDs (they are installed at an angle and have a bright enclosure).
3. Position the cleaning unit in such a way that the nozzle is located at the side of the two LEDs (see →  10).
4. Fix the cleaning unit in place with the securing screw (max. torque: 0.5 Nm (0.37 lbf ft)).
5. Insert the compressed air hose of the compressor into the hose connection.

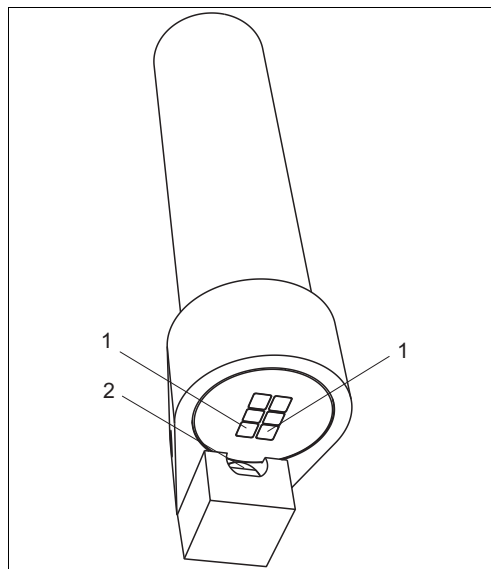

Fig. 10: Aligning the cleaning unit

- | | |
|---|--------|
| 1 | LEDs |
| 2 | Nozzle |

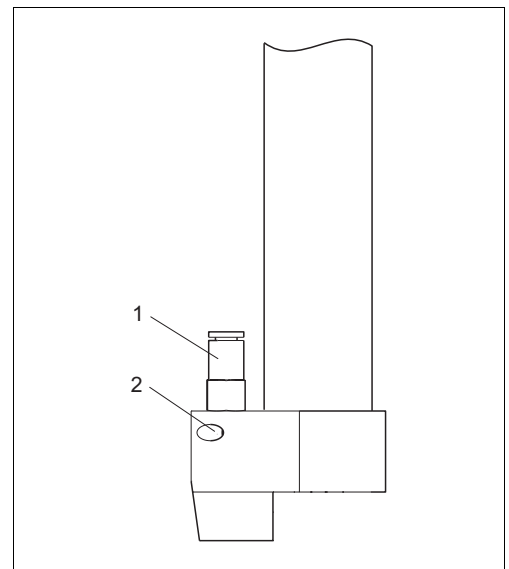

Fig. 11: Fixing the cleaning unit

- | | |
|---|-----------------|
| 1 | Hose connection |
| 2 | Securing screw |

3.3.2 Pipe installation

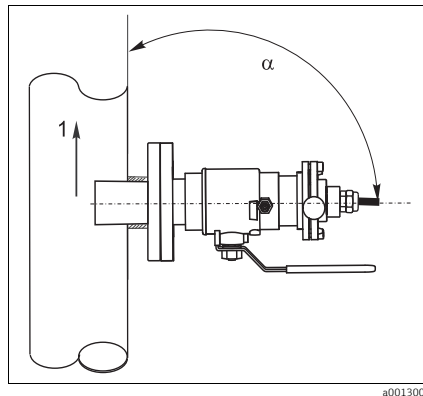

Fig. 12: Installation with retractable assembly

Arrow 1 shows the flow direction.
 The installation angle α must not exceed 90° .
 The recommended installation angle is 75° .
 The optical windows of the sensor have to be aligned parallel to the flow direction ($\alpha = 90^\circ$) or face the flow direction ($\alpha < 90^\circ$).
 For manual insertion/retraction of the assembly the medium pressure may not exceed 2 bar (29 psi).

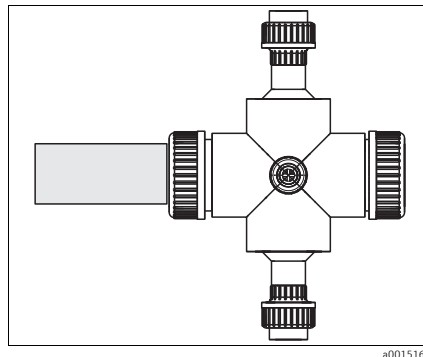

Fig. 13: Installation with flow assembly CYA251

The installation angle is 90° .
 Turbidity measurement < 200 FNU will result in erroneous measuring results due to backscattering of pipe wall.

The following figure illustrates various installation positions in pipes and indicates whether they are permitted or not.

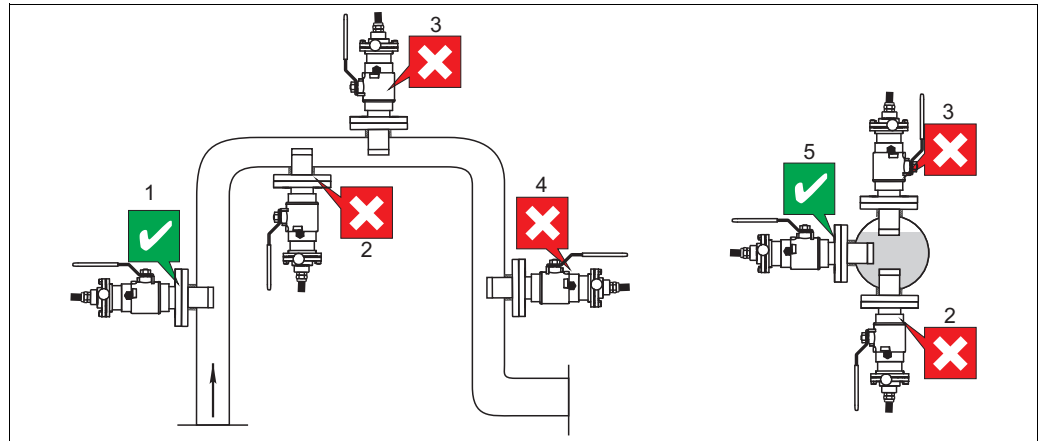

Fig. 14: Orientation and installation positions (with retractable assembly CUA451)

- The pipeline diameter must be at least 100 mm (4") if reflective materials (e.g. stainless steel) are used. An on-site calibration is recommended.
- Install the sensor in places with uniform flow conditions.
- The best installation location is in the ascending pipe (it. 1). Installation is also possible in the horizontal pipe (it. 5).
- Do not install the sensor in places where air may collect or foam bubbles form (it. 3) or where suspended particles may settle (it. 2).
- Avoid installation in the down pipe (it. 4).
- Turbidity measurement < 200 FNU will result in erroneous measuring results due to backscattering of pipe wall. Therefore a multipoint calibration is recommended.
- Avoid installations behind pressure reduction steps which can outgas.

3.4 Post-installation check

- ▶ Sensor and cable undamaged?
- ▶ Cap undamaged?
- ▶ Compliance with permissible sensor installation position?
- ▶ Is the sensor installed in an assembly and is not suspended from the cable?
- ▶ Avoid moisture by rain by putting the protective cap on the assembly?

4 Wiring

▲ WARNING

Device is energized

Improper connection can cause injury or death.

- ▶ The electrical connection must only be carried out by a certified electrician.
- ▶ Technical personnel must have read and understood the instructions in this manual and must adhere to them.
- ▶ **Prior to beginning** any wiring work, make sure voltage is not applied to any of the cables.

4.1 Connecting to the transmitter

The sensor will be connected to the transmitter as follows:

- With the M12 plug (version: fixed cable, M12 plug) or
- With the fixed cable connected to the terminal strips (version: fixed cable, end sleeves):

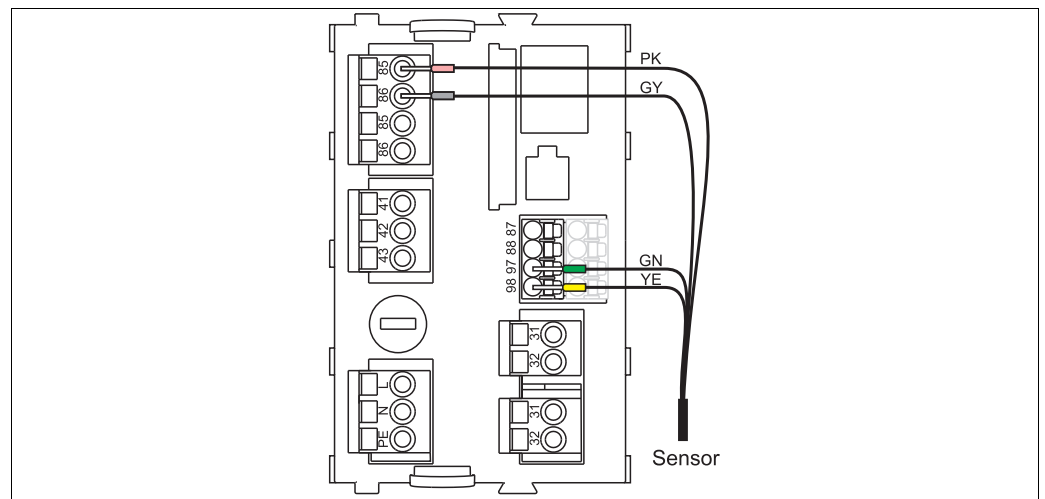

Fig. 15: Sensor connection

The maximum cable length is 100 m (328 ft).

4.2 Post-connection check

Instrument status and specifications	Remarks
Are the sensor, assembly, junction box or cable damaged?	Visual inspection
Electrical connection	Remarks
Does the supply voltage of the transmitter match the specifications on the nameplate?	
Are the installed cables strain-relieved and not twisted ?	
Is the cable type route completely isolated ?	Power cable/weak current cable
Are the power supply and signal cable correctly connected to the transmitter ?	Use the connection diagram of the transmitter.
Long enough length of cable core stripped and correct in terminal?	Check seating (pull slightly)
Are all the screws terminals properly tightened ?	Tighten
Are all the cable entries installed, tightened and sealed ?	For cable entries lateral: cable loops downwards for water to be able to drip off.
Are all the cable entries installed downwards or lateral ?	

5 Device description

5.1 Sensor design

The sensor is designed for the continuous in-situ measurement of turbidity and solids content.

The sensor is designed as a 40 mm sensor that can be operated directly and completely in the process without the need for further sampling (in situ).

All the necessary modules are contained in the sensor:

- Power supply
- Light sources
- Detectors detect the measuring signals, digitize them and process them to form a measured value.
- The sensor microcontroller is responsible for controlling the internal processes and transmitting the data.

All the data - including the calibration data - are stored in the sensor. The sensor can thus be precalibrated and used at a measuring point, calibrated externally, or used for several measuring points with different calibrations.

5.2 Measuring principle

For turbidity measurement a light beam is sent through the medium and is diverted from its original direction by optically denser particles, e.g. solid matter particles. This process is also called scattering.

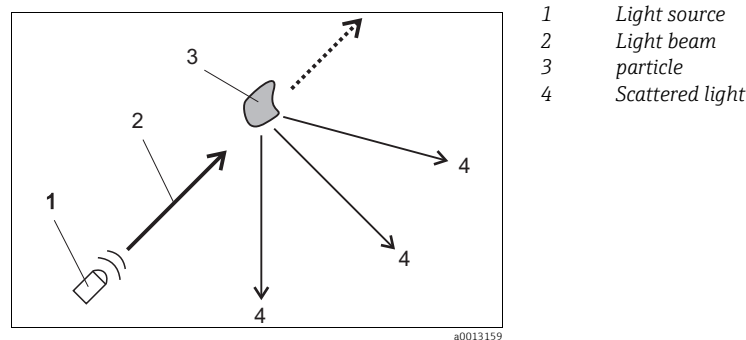

Fig. 16: Deflection of the light

The impinging light will be scattered in different angles. Two angles are of interest in this matter:

- The scattered light in the 90° direction is less influenced by the size of the particles.
- The scattered light in the 135° direction gives enough information also at a high number of particles.

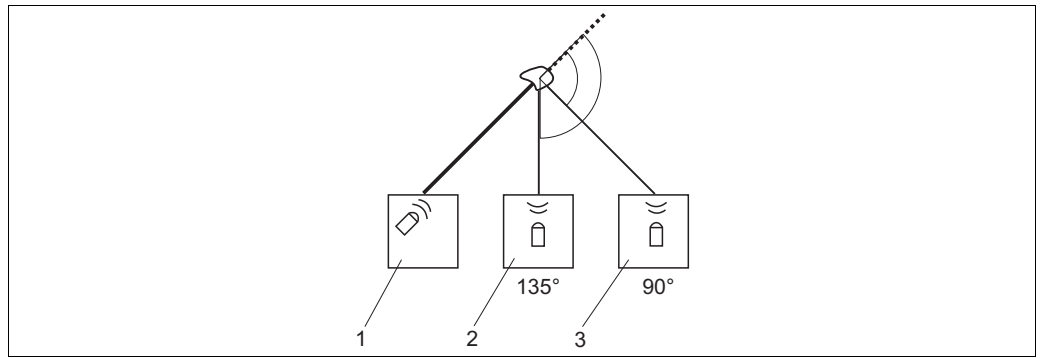

Fig. 17: Principle operating mode of the turbidity sensor

- 1 Light source
- 2 135° light receiver
- 3 90° light receiver

If only a small number of particles is in the medium, most of the light will be scattered to the 90° channel and less light will be scattered to the 135° channel. When the number of particles increases the relationship will change (more light scattered to the 135° channel, less light scattered to the 90° channel).

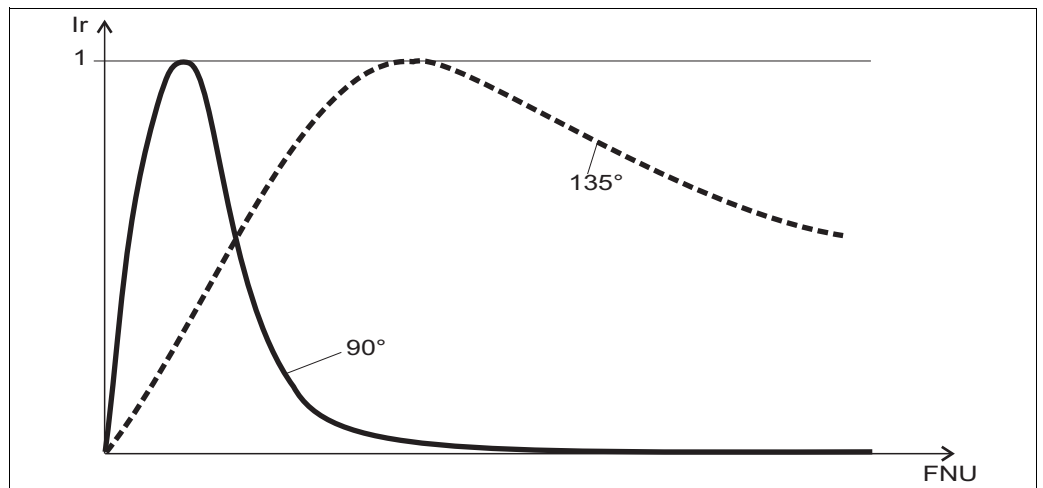

Fig. 18: Signal distribution depending on the number of particles

Ir Relative intensity

The turbidity sensor CUS51D is equipped with two independent sensor units that are arranged in parallel. The application-specific analysis of both signals results in stable measured values.

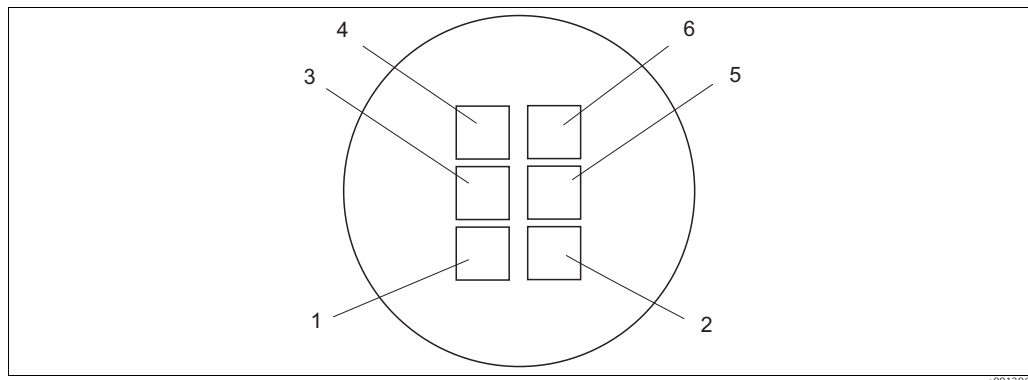

Fig. 19: Arrangement of the light sources and the light receivers

- 1,2 Light sources 1 and 2
 3,5 135° light receivers
 4,6 90° light receivers

This allows the optimal turbidity and suspended solids measurement:

- For low turbidity values preferably the 90° channel is used.
- For average and high turbidity values and for suspended solids measurement the 135° channel is used.
- The dual sensor technology allows operation with a large range of soiling compensation, e.g. suspended solids measurement in the activated sludge basin (basis: four-beam pulsed light).

Based on the chosen application the appropriate model is used automatically inside the sensor.

- i** The available sensor types differ in their measuring ranges and therefore in the selection of the available applications.

5.3 Measuring methods

Four-beam pulsed light method

The method is based on two light sources and four light receivers. Long-life LEDs are used as monochromatic light sources. To eliminate interference from extraneous light sources, these LEDs are pulsed.

Two measuring signals are detected at the four light receivers. The eight measuring signals are processed in the sensor and are converted into turbidity units and solids concentrations. The four-beam pulsed light method compensates the sensor soiling as well as the wearing of the optical components.

The number of the used signals depends on the application.

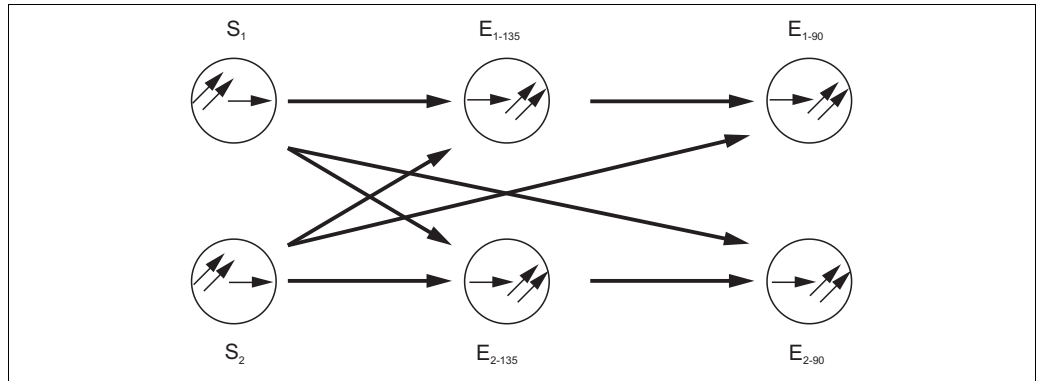

Fig. 20: Four-beam pulsed light method

$S_1 S_2$ Light sources

E_{90} 90° channel light-receiver

E_{135} 135° channel light-receiver

90° scattered light method

The measurement uses a wavelength of 860 nm like described in ISO 7027 / EN 27027. The transmitted light beam is scattered by the solid matter particles in the medium. The scattered beams are detected by scattered light receivers which are arranged at an angle of 90° to the light sources. The turbidity of the medium is determined by the amount of the scattered light.

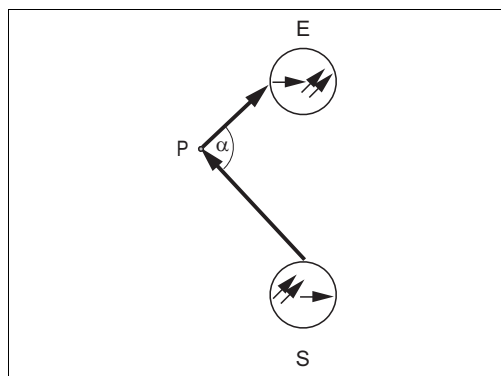

S = Light source
 E = Light receiver
 P = Particle

Fig. 21: Principle of the 90° scattered light method

135° backscattered light method

The transmitted light beam is scattered by the solid matter particles in the medium. The backscattered beams are detected by scattered light receivers, which are arranged next to the light sources. The turbidity of the medium is determined by the amount of backscattered light.

This method is used to measure high turbidity values.

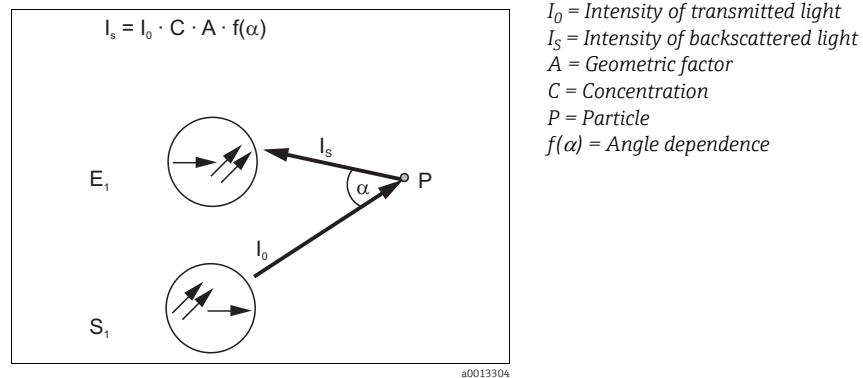

Fig. 22: Principle of backscattered light method

5.4 Application

The sensor enables measurement in a variety of ways that are adapted to suit the specific measurement problems. The method is set by the choice of application and the reference model.

Application type "Clear water"

Application	Method	Measuring range
Formazine	135° turbidity, single channel	0 to 4000 FNU Display range up to 9999 FNU
Kaolin	135° turbidity, single channel	0 to 5 g/l
TiO ₂ (titanium oxide)	4-beam pulsed light, 135°	0 to 150 g/l
SiO ₂ (silicon dioxide)	4-beam pulsed light, 135°	5 to 100 g/l

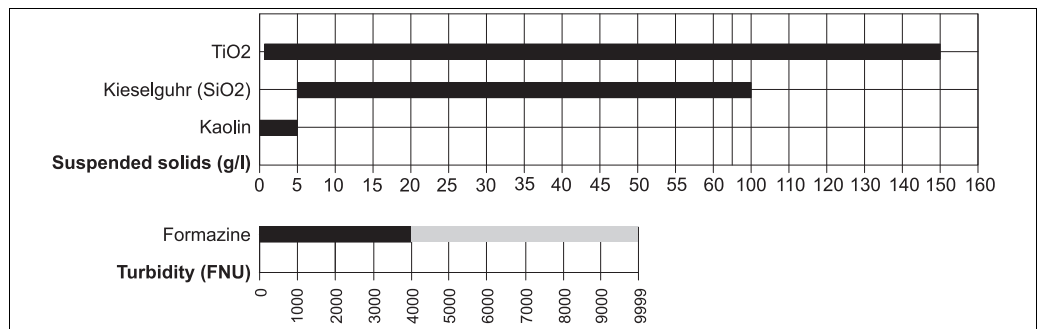

a0020168-en

Application type "Solids"

Application	Method	Measuring range
Thin sludge	135° turbidity, single channel	0 to 5 g/l
Sludge activation	4-beam pulsed light, 90°	2 to 15 g/l
Return sludge	4-beam pulsed light, 135°	3 to 50 g/l
Digested sludge / ooze	135° turbidity, single channel	5 to 100 g/l / 300 g/l

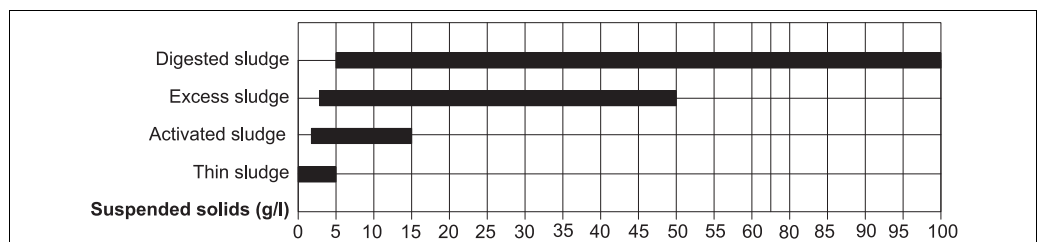

a0020169-en

Application areas

Model name	Application	Unit	Compensation*
Formazine	Process water, sewage treatment plant outlet	FTU / FNU	
Kaolin	Filterable solids, process water, sewage treatment plant outlet, activated sludge in low concentration	mg/l ; g/l; ppm; %	
SiO ₂	SiO ₂ , mineralic solids (sands)	g/l; ppm; %	X
TiO ₂	TiO ₂ , (white medium)	g/l; ppm; %	X
Thin sludge	From activated sludge down to clear water	g/l; ppm; %	
Activated sludge	Activated sludge basin and comparable medium	g/l; ppm; %	X
Excess sludge	Excess sludge, primary sludge, thickened sludge	g/l; ppm; %	X
Digested sludge	Digested sludge, black - homogeneous	g/l; ppm; %	

* compensation of contamination with four-beam pulsed light

 Detailed information about application areas are described in the following section "Calibration".

5.5 Calibration

The sensor is precalibrated on leaving the factory. As such, it can be used in a wide range of applications (e.g. clear water measurement) without the need for additional calibration. The factory calibrations are based on "three-point calibration". The kaolin and formazine applications are already fully calibrated and can be used without further calibration.

All other applications are pre-calibrated with reference samples and need to be calibrated to the appropriate application.

In addition to the factory calibration data, which cannot be modified, the sensor has five other data records to be used for storing process calibrations.

5.5.1 Selecting the application

-  On the CM44x, select the appropriate application for your field of application during initial commissioning. This application can be adopted during calibration or can be reselected by you.

Wastewater application

	Turbidity (formazine, FTU)	Kaolin (mg/l, g/l)	Diluted sludge (mg/l, g/l)	Sludge activation (mg/l, g/l)	Waste activated sludge (WAS) (g/l, % of TS)	Digested sludge (g/l, % of TS)
Wastewater treatment plant inlet	(X)		(X)		X	
Primary sludge extraction, primary clarification					X	(X)
Aeration basin, range 0 - 5 g/l, e.g. SBR			X			
Aeration basin, range 2 - 15 g/l				X	(X)	
Recirculation line					X	
Waste activated sludge extraction					X	X
Sludge thickener (primary sludge)					X	(X)
Digester inlet					X	(X)
Digester outlet (sludge)					(X)	X
Wastewater treatment plant outlet	X	X	(X)			
Sand filter control	X		X			

-  Depending on the arrangement of the facility, individual measuring points can be declared as Ex zones.

Process water application

	Turbidity (formazine, FTU)	Kaolin (mg/l, g/l)	SiO ₂ (ppm, g/l)	TiO ₂ (ppm, g/l)	Dilute sludge (mg/l, g/l)	Waste activated sludge (WAS) (g/l, % of TS)	Digested sludge (g/l, % of TS)
Inlet	X	X					
Process control			X	X			
Filter rinsing	X	X			(X)		
Sedimentation tank					X	X	X
Process water	X	X	X	X			
Process sludges	X	X	X	X			

5.5.2 Choosing the type of calibration

1 to 5 points can be calibrated for all applications.

The following recommendation describes the common types of calibration.

Model	Single-point calibration (in the medium)	Two-point or multipoint (outside the medium)
Formazine	X	
Kaolin	X	
SiO ₂		X
TiO ₂		X
Dilute sludge	X	
Activated sludge		X
Waste activated sludge (WAS)		X
Digested sludge		X

 With the "dilute sludge" model, measurements can be carried out in the aeration basin up to approx. 5 g/l. This model has the advantage of being able to be calibrated at a single point in the process during operation.

Effects of the various types of calibration

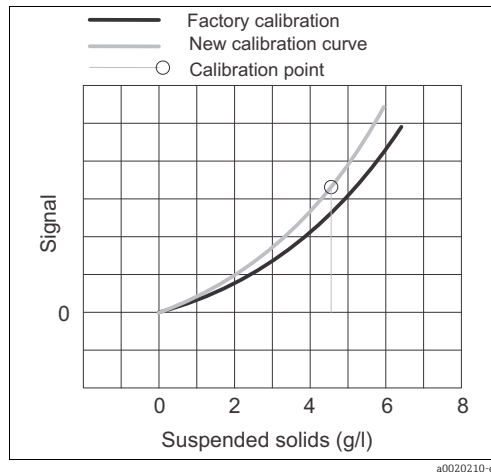

Fig. 23: Single-point calibration

Single-point calibration causes a change in the slope.

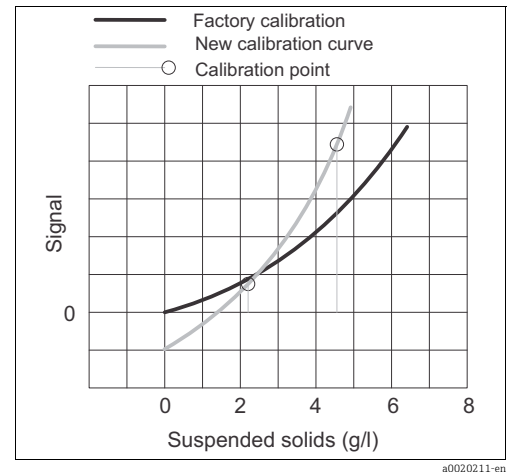

Fig. 24: Two-point calibration

Two-point calibration causes a change in the slope and the zero point. This type of calibration is used if the measured value changes across a wide range.

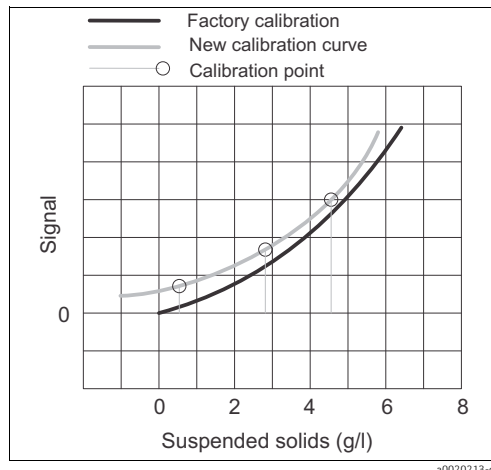

Fig. 25: Three-point calibration

With three-point calibration, a new calibration curve is drawn through all three calibration points. This leads to higher accuracy in the calibrated range.

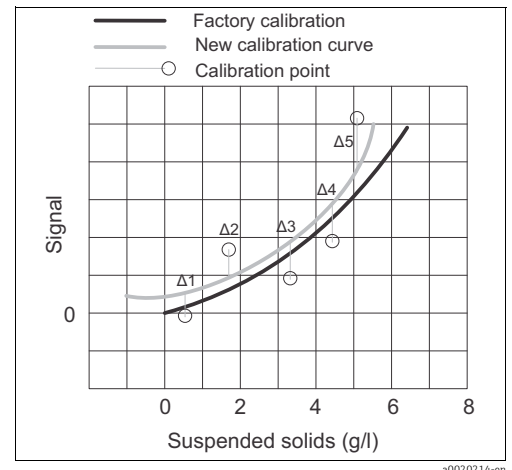

Fig. 26: Five-point calibration

With four- or five-point calibration, the calibration curve between the calibration points is determined. This leads to better alignment with the selected calibration points; however, it does not improve accuracy.

Single-point and two-point calibration are based on the data record stored internally in the device.

Calibration at three or more points always causes the measuring curve to be recalculated.



With multipoint calibration, the calibration points must always cover the complete measuring range of the application. Furthermore, no points outside the specified measuring range of the application may be selected.

In this way, a calibration with zero water (0 g/l) usually results in unusable calibrations for the following applications:

- Activated sludge
- Waste activated sludge (WAS)
- Digested sludge
- SiO₂

5.5.3 Single-point calibration

With single-point calibration, the sensor can remain immersed in the process medium.

Proceed as follows:

1. Remove a sample of the medium in close proximity to the sensor for the laboratory measurement.
2. Send the sample to the laboratory to measure the turbidity or solids content.
3. Select a data record in the CM44x transmitter.
4. Start the calibration as simultaneously as possible to the sampling and enter the laboratory value of the sample as the set point.
If there is no laboratory value available during calibration, enter an approximate value as the set point. As soon as the laboratory value is available, you can edit the set point on the transmitter retrospectively.

5.5.4 Multipoint calibration

⚠ CAUTION

Risk of injury due to acid or medium

- ▶ Switch off the cleaning unit before removing the sensor from the medium.

Sample preparation:

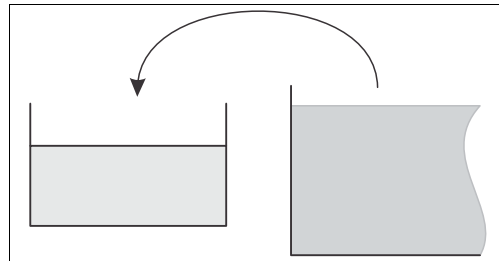

1. Remove a sample from the process (e.g. 10 liters - bucket).

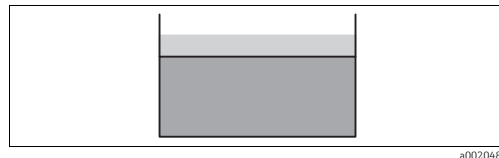

2. Wait until the sludge parts have settled.

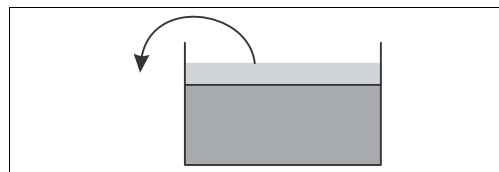

3. Remove the residual water (if possible). You now have a sample with an increased concentration. Stir the sample to increase the homogeneity.

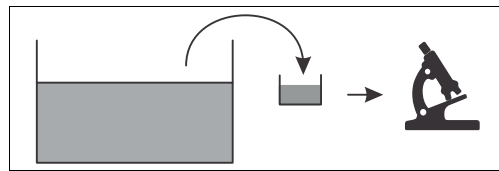

4. Remove part of the sample for analysis in the laboratory.

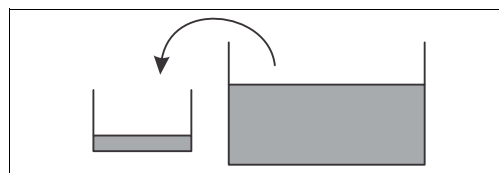

5. Add a defined part of the sample (e.g. 2 liters) to the calibration vessel (black bucket) Stir the sample again to maintain the homogeneity.

Preparing the CUS51D sensor for calibration:

1. Clean the optical components (windows) of the sensor with water and a brush.
2. Put the sensor into the calibration vessel. When doing this, observe the following instructions.
 - Do not immerse the sensor vertically into the sample. Immerse the sensor at an angle. By doing this, you will prevent air bubbles building up around the windows.

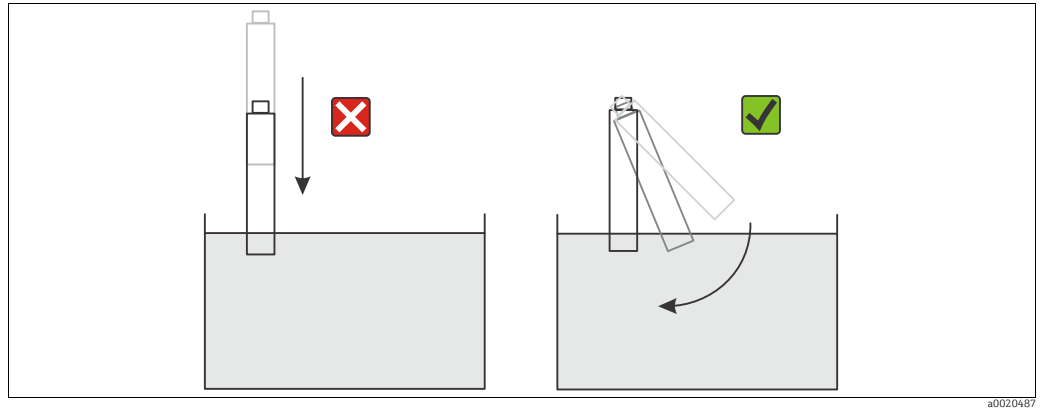

Fig. 27: Immersing the sensor

- The LEDs on the sensor should be directed towards the middle of the calibration vessel.
- The minimum clearance between the sensor and the wall of the vessel is 10 mm (0.4 inches).
- The distance to the floor of the vessel should be as large as possible, but at the same time, the sensor must be immersed at least 10 mm (0.4 inches).

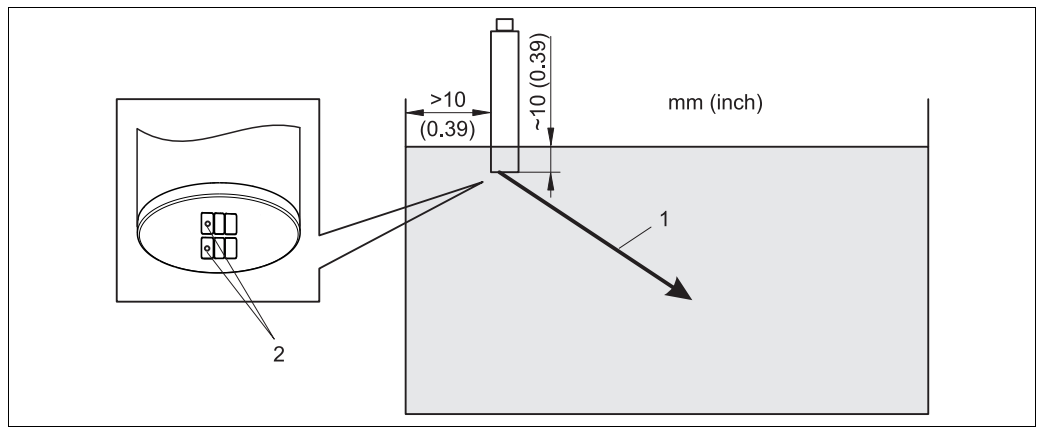

Fig. 28: Positioning the sensor

- 1 Beam direction of the LEDs
- 2 LEDs

- Fix the sensor in this position (ideally with a laboratory stand).
- During calibration, make sure the medium is as homogeneous as possible. A magnetic stirrer would be the best solution.

During calibration, note the following points:

- The calibration points should cover the complete measuring range.
- Be extremely careful when determining the laboratory measured value (the quality of the laboratory measurement has a direct impact on the accuracy of the sensor).
- Use a graduated cylinder to measure the volumes for the sample and the dilution water with the highest possible accuracy.
- Air bubbles on the optical components distort the calibration result significantly and must therefore be removed before each calibration.
- Ensure that the medium is always well mixed (homogeneity).
- Avoid changes in temperature during calibration, and make sure the dilution water and the medium are the same temperature, as far as possible.
- The position of the sensor should not be changed during calibration.
- The calibration set points can also be edited retrospectively in the CM44x (e.g. if the reference value of the laboratory measurement is not known at the time of calibration).

Carrying out a calibration (example of a three-point calibration):

1. Select a data record in the CM44x transmitter.
2. Wait for at least one minute (for stabilization).
3. Start the calibration for measuring point 1 (example: 2 l sample with a concentration of 6 g/l).
Enter the value of the sample determined in the laboratory as the set point (example: 6 g/l) or adopt the suggested value and adapt it later to the laboratory value.

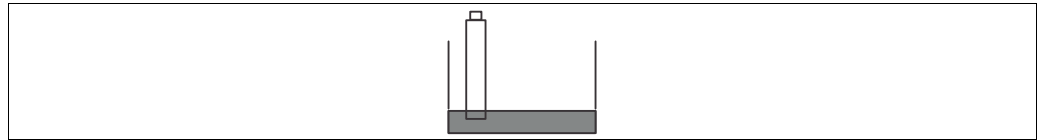

4. Dilute the sample to a ratio of 1:2 (add 2 l water to produce 3 g/l in the example)

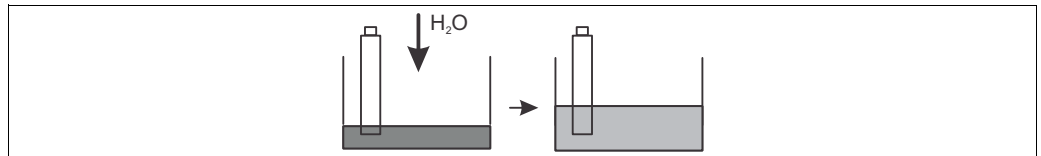

5. Avoid the build-up of air bubbles under the sensor.
6. Calibrate measuring point 2.
Enter half of the laboratory value as the set point or edit the value later.
7. Dilute the sample to a ratio of 1:3 (add 2 l water to produce 2 g/l in the example)

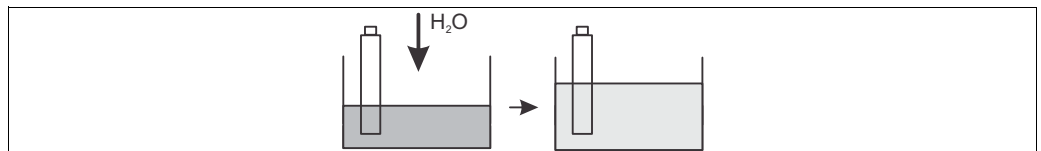

8. Avoid the build-up of air bubbles under the sensor.
9. Calibrate measuring point 3.
Enter a third of the laboratory value as the set point or edit the value later.

 You can also carry out the calibration in increasing concentrations (less advisable).

5.6 Stability criterion

During the calibration process, the measured values returned by the sensor are checked to ensure they remain constant. The stability criterion defines the maximum amount the measured values may deviate during calibration and still be accepted.

The data comprise:

- The maximum permissible deviation in temperature measurement
- The maximum permissible deviation in the measured value in %
- The minimum timeframe in which these values must be maintained

As soon as the stability criteria for the signal values and the temperature are reached, the calibration is continued. If these criteria are not fulfilled within the maximum time frame of 5 minutes, no calibration takes place, and a warning is displayed.

The stability criteria monitor the quality of the individual calibration points in the course of the calibration. The aim is to achieve the best possible calibration quality in a short timeframe while taking external conditions into account.

-  For calibrations in the field under tough weather and environmental conditions, the measured value windows selected can be large and the timeframe short.

5.7 Cyclic cleaning

Compressed air is most suitable for cyclic cleaning. The optional cleaning unit is either ready-supplied or can be retrofitted, and is fitted on the sensor head. It operates at a rate of 50 l/min (13.2 US gal/min)

The following settings are recommended for the cleaning unit:

Type of fouling	Cleaning interval	Cleaning duration
Severe fouling with rapid buildup	5 min	10 s
Low degree of fouling	10 min	10 s

6 Diagnostics and troubleshooting

Troubleshooting must take account of the whole measuring system:

- Transmitter
- Electrical leads and connectors
- Assembly
- Sensor

The possible causes of failure listed in the following table primarily refer to the sensor.

Problem	Check	Remedy
No display, no sensor reaction	Mains voltage at transmitter? Sensor connected correctly? Film formation on optical windows?	Connect mains voltage. Set up correct connection. Clean the sensor.
Reading too high or too low	Film formation on optical windows? Sensor calibrated?	Clean the sensor. Calibrate.
Reading greatly fluctuating	Check mounting location.	Select other mounting location.

-  Please pay special attention to the instructions on handling errors in the Operating Instructions of the transmitter. Check the transmitter, if necessary.

7 Maintenance

You have to perform maintenance tasks at regular intervals.

We recommend setting the maintenance times in advance in an operations journal or log. The maintenance cycle primarily depends on the system, the installation conditions and the medium in which measurement takes place.

CAUTION

Risk of injury caused by acid or medium

- ▶ Switch off the cleaning unit before removing the sensor from the medium.

7.1 Cleaning the sensor

Sensor fouling can affect the measurement results and even cause a malfunction.

The sensor must be cleaned at regular intervals to ensure reliable measurement results. The frequency and intensity of the cleaning process depends on the medium.

Clean the sensor:

- As specified in the maintenance schedule
- Before every calibration
- Before returning the sensor for repair

Type of fouling	Cleaning measure
Lime deposits	Immerse the sensor in 1-5 % hydrochloric acid (for a few minutes).
Dirt particles on the optical windows	Use a cloth to clean the optical windows.

-  You must rinse the sensor thoroughly with water after cleaning.

8 Repair

8.1 Return

The device must be returned if repairs or a factory calibration are required, or if the wrong device has been ordered or delivered. According to legal regulations, Endress+Hauser, as an ISO-certified company, is required to follow certain procedures when handling returned products that are in contact with medium.

To ensure swift, safe and professional device returns, please read the return procedures and conditions on the internet site:

www.services.endress.com/return-material

8.2 Disposal

The device contains electronic components and must therefore be disposed of in accordance with regulations on the disposal of electronic waste.

Please observe local regulations.

9 Accessories

9.1 Assemblies

Wastewater assembly Flexdip CYA112

- Modular assembly system for sensors in open basins, channels and tanks
- Versions in stainless steel or PVC
- Ordering per product structure (--> Online configurator: www.products.endress.com/cya112)
- Technical Information TI00432C/07/EN

Retractable assembly Cleanfit CUA451

- Retractable assembly with ball valve; for turbidity sensors; material: stainless steel
- Ordering per product structure (--> Online configurator, www.products.endress.com/cua451)
- Technical Information TI00369C/07/EN

Flow assembly Flowfit CYA251

- Connection: see product structure
- Material: PVC-U
- Order as per product structure

9.2 Holder

Holder system Flexdip CYH112 for water and wastewater assembly CYA112

- Modular holder system for sensors and assemblies in open basins, channels and tanks
- The holder system CYH112 works for nearly any type of fixing - fixing on the floor, wall or directly on a rail.
- Material: stainless steel
- Ordering acc. to product structure (--> Online configurator: www.products.endress.com/cyh112)
- Technical Information TI00430C/07/EN

9.3 Compressed air cleaning

Cleaning system with pressurized air

- Connection: 6 or 8 mm (metric) or 6.35 mm (1/4")
- Materials: POM/V4A
- 6/8 mm order number: 71110782
- 6.35 mm (1/4") order number: 71110783

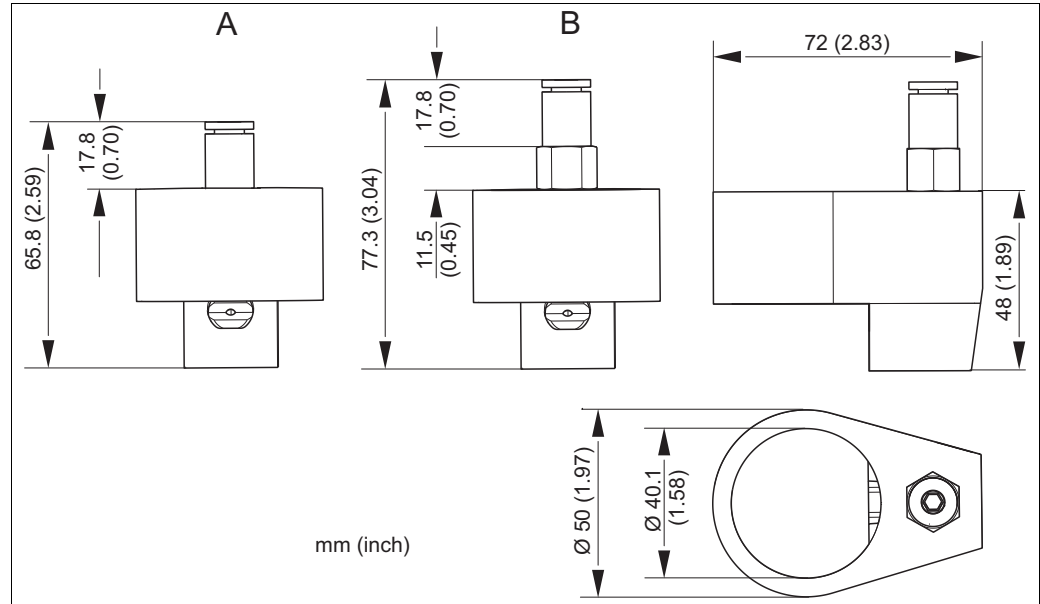

Fig. 29: Cleaning system

- A Version 6 mm
B Version 6.35 mm (1/4")

Compressor

- For cleaning system
- 230 V AC order number: 71072583
- 115 V AC order number: 71194623

9.4 Transmitter

Liquiline CM442/CM444/CM448

- Multiple-channel transmitter for the connection of digital sensors with Memosens technology
- Power supply: 100 to 230 V AC, 24 V AC/DC
- Universally upgradeable
- SD card slot
- Alarm relay
- IP 66, IP67, NEMA 4X
- Ordering per product structure (--> Online configurator on product page)

10 Technical Data

10.1 Input

Measured variable	Turbidity Solids content Temperature		
Measuring range	CUS51D-**C1		Application
	Turbidity	0 to 4000 FNU display range up to 9999 FNU	Formazine
	Solids content	0 to 4 g/l	Kaolin, filterable solids
	Temperature	-20 to +80 °C (-4 to +176 °F)	
	CUS51D-**D1		Application
	Turbidity	0 to 4000 FNU display range up to 9999 FNU	Formazine
Solids content	0 to 300 g/l 0 to 30 %	Solids content according to chosen application (see list)	
Temperature	-20 to +80 °C (-4 to +176 °F)		

-  Measuring range of solids content:
For solids the achievable measuring ranges are depending of the actual medium and can deviate from the recommended operating ranges. Nonhomogeneous media produce fluctuations in measured values and restrict the measuring range.

10.2 Performance characteristics

Maximum measured error	Turbidity	< 2% of the measured value or 0.1 FNU (the respectively larger value is valid)
	Solids	< 5 % of the measured value or 1 % of full scale (the respectively larger value is valid); valid for sensors in the calibrated measuring range

Wavelength 860 ± 30 nm

Applications The sensor is factory calibrated in the application "formazine" and hereof derived for "kaolin filterable solids)". Further precalibrated applications are optimized for the corresponding medium.
The calibration can be performed up to 5 points.

Application water	Recommended working ranges	CUS51D-	
		C1	D1
Factory calibration formazine	0 to 4000 FNU	X	X
Factory calibration kaolin	0 to 4 g/l	X	X
Application SiO ₂	5 to 100 g/l		X
Application titanium dioxide	0.2 to 150 g/l		X

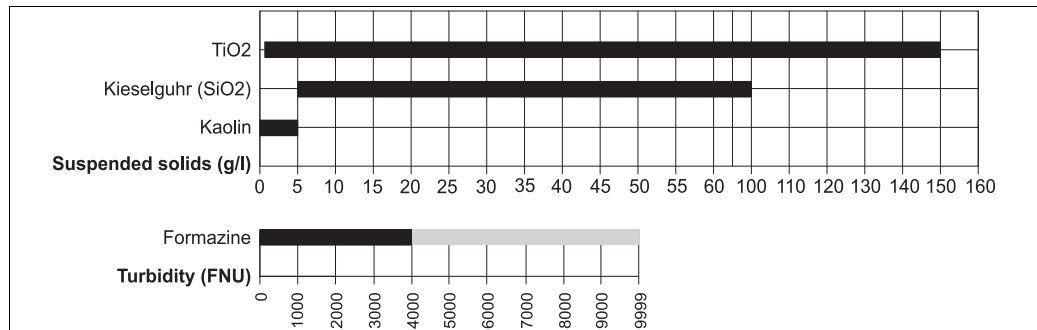

a0020168-en

Application wastewater	Recommended working ranges	CUS51D-	
		C1	D1
Application thin sludge	0 to 5 g/l		X
Application activated sludge	0.5 to 15 g/l		X
Application excess sludge	3 to 50 g/l		X
Application digested sludge / ooze	5 to 100 g/l / 300 g/l		X

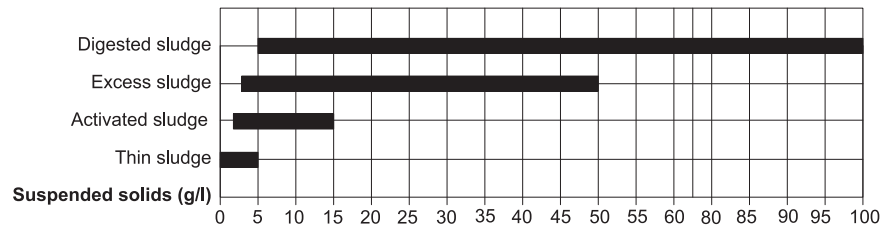

a0020169-en

i For solids the achievable measuring ranges are depending of the actual medium and can deviate from the recommended operating ranges.

Factory calibration FNU, FTU and solids concentration according to the application table
Standard: 3 points

Drift Thanks to electronic control the sensor works drift compensated in a wide range.

Limit of detection	Application	Measuring range	Limit of detection
	Formazine		0 to 50 FNU
		0 to 9999 FNU	0.4 FNU
	Kaolin	0 to 4000 mg/l	0.85 mg/l

10.3 Environment

Ambient temperature range -20 to 60 °C (-4 to 140 °F)

Storage temperature -20 to 70 °C (-4 to 158 °F)

Ingress protection IP 68 (test conditions: 1 m (3.3 ft) water column during 60 days, 1 mol/l KCl)

10.4 Process

Process temperature -5 to 50 °C (23 to 120 °F)
max. 80 °C (175 °F) short term(1 h)

Process pressure 0.5 to 10 bar (7 to 145 psi) absolute

Minimum flow No minimum flow required.
Make sure that there is a sufficient turbulence for solids with a tendency to sedimentation.

10.5 Mechanical construction

Dimensions See "Installation conditions"

Weight approx. 0.7 kg (1.5 lbs) without cable

Materials	Sensor	Stainless steel 1.4404 (AISI 316 L) or Stainless steel 1.4571 (AISI 316 L)
	Optical windows	Sapphire
	O-rings	EPDM

Process connections G1 and NPT ¾"

Index

A

Accessories	33
Ambient temperature range	37
Application	21
Applications	36
Assemblies	33

C

Calibration	23
Multipoint	26
Single point	26
Checking	
Installation	14
Cleaning	31
Compressed air cleaning	29, 34
Connection	
Transmitter	15

D

Declaration of conformity	6
Designated use	4
Dimensions	7
Disposal	32
Drift	37

E

Electromagnetic compatibility	4
-------------------------------------	---

F

Factory calibration	37
---------------------------	----

H

Holder	33
--------------	----

I

Identifying the product	6
Immersion operation	10
Incoming acceptance	6
Ingress protection	37
Input	
Measured variable	35
Measuring range	35
Installation	7–8
Installation examples	10

M

Maintenance	31
Materials	38
Maximum measured error	36
Measured variable	35
Measuring methods	19
Measuring principle	16
Measuring range	35
Measuring system	8
Minimum flow	37
Multipoint calibration	26

N

Nameplate	6
-----------------	---

O

Operational safety	4
--------------------------	---

P

Pipe installation	13
Post-connection check	15
Process calibration	23
Process connections	38
Process pressure	37
Process temperature	37
Product identification	6
Product safety	5

R

Requirements for the personnel	4
Return	32

S

Scope of delivery	6
Sensor design	16
Single-point calibration	26
Stability criterion	29
Storage temperature	37

T

Technical Data	35
Transmitter	34
Transmitter connection	15

U

Use	4
-----------	---

W

Wavelength	36
Weight	38
Wiring	15
Workplace safety	4



71219749

www.addresses.endress.com
