

Operating Instructions

Proline t-mass T 150

HART

Thermal mass flowmeter

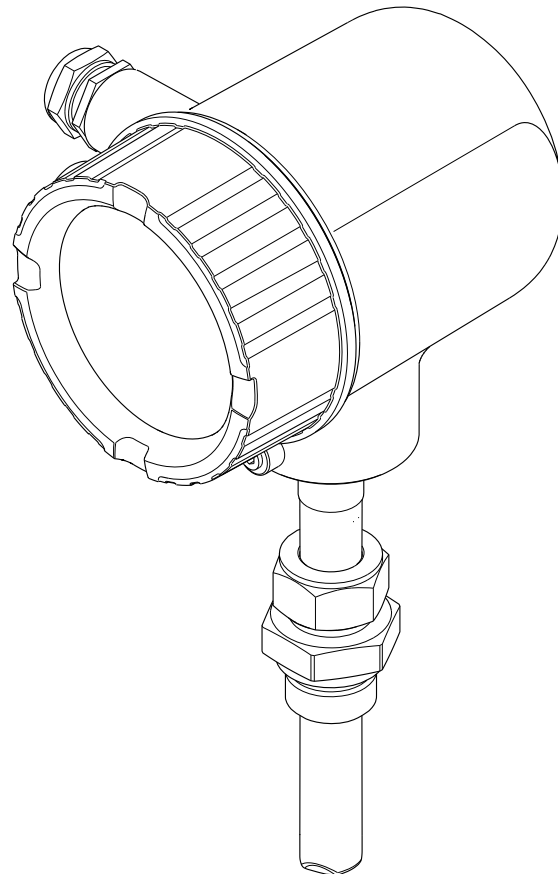

- Make sure the document is stored in a safe place such that it is always available when working on or with the device.
- To avoid danger to individuals or the facility, read the "Basic safety instructions" section carefully, as well as all other safety instructions in the document that are specific to working procedures.
- The manufacturer reserves the right to modify technical data without prior notice. Your Endress+Hauser Sales Center will supply you with current information and updates to these Instructions.

Table of contents

1	Document information	6	7	Electrical connection	28
1.1	Document function	6	7.1	Connection conditions	28
1.2	Symbols used	6	7.1.1	Required tools	28
1.2.1	Safety symbols	6	7.1.2	Requirements for connecting cable	28
1.2.2	Electrical symbols	6	7.1.3	Terminal assignment	28
1.2.3	Tool symbols	7	7.1.4	Pin assignment of the connector	29
1.2.4	Symbols for certain types of information	7	7.1.5	Requirements for the supply unit	29
1.2.5	Symbols in graphics	7	7.1.6	Preparing the measuring device	29
1.3	Documentation	8	7.2	Connecting the measuring device	30
1.3.1	Standard documentation	8	7.2.1	Connecting the cables	30
1.3.2	Supplementary device-dependent documentation	8	7.3	Ensuring the degree of protection	31
1.4	Registered trademarks	8	7.4	Post-connection check	31
2	Basic safety instructions	9	8	Operation options	33
2.1	Requirements for the personnel	9	8.1	Overview of operation options	33
2.2	Designated use	9	8.2	Structure and function of the operating menu	33
2.3	Workplace safety	10	8.2.1	Structure of the operating menu	33
2.4	Operational safety	10	8.2.2	Operating philosophy	35
2.5	Product safety	10	8.3	Access to the operating menu via the local display	36
2.6	IT security	11	8.3.1	Operational display	36
3	Product description	12	8.3.2	Navigation view	38
3.1	Product design	12	8.3.3	Editing view	40
4	Incoming acceptance and product identification	13	8.3.4	Operating elements	42
4.1	Incoming acceptance	13	8.3.5	Opening the context menu	43
4.2	Product identification	14	8.3.6	Navigating and selecting from list	44
4.2.1	Transmitter nameplate	14	8.3.7	Calling the parameter directly	44
4.2.2	Sensor nameplate	15	8.3.8	Calling up help text	45
4.2.3	Symbols on measuring device	16	8.3.9	Changing the parameters	46
5	Storage and transport	17	8.3.10	User roles and related access authorization	47
5.1	Storage conditions	17	8.3.11	Disabling write protection via access code	47
5.2	Transporting the product	17	8.3.12	Enabling and disabling the keypad lock	47
5.3	Packaging disposal	17	8.4	Access to the operating menu via the operating tool	49
6	Installation	18	8.4.1	Connecting the operating tool	49
6.1	Installation conditions	18	8.4.2	Field Xpert SFX350, SFX370	50
6.1.1	Mounting position	18	8.4.3	FieldCare	50
6.1.2	Requirements from environment and process	24	8.4.4	AMS Device Manager	51
6.2	Mounting the measuring device	25	8.4.5	SIMATIC PDM	51
6.2.1	Required tools	25	8.4.6	Field Communicator 475	52
6.2.2	Preparing the measuring device	25	9	System integration	53
6.2.3	Mounting the measuring device	25	9.1	Overview of device description files	53
6.2.4	Turning the transmitter housing	26	9.1.1	Current version data for the device	53
6.2.5	Turning the display module	27	9.1.2	Operating tools	53
6.3	Post-installation check	27	9.2	Measured variables via HART protocol	53
			9.3	Other settings	54

10	Commissioning	55	12.4	Adapting the diagnostic information	96
10.1	Function check	55	12.4.1	Adapting the diagnostic behavior	96
10.2	Switching on the measuring device	55	12.5	Overview of diagnostic information	97
10.3	Setting the operating language	55	12.6	Pending diagnostic messages	99
10.4	Configuring the measuring device	56	12.7	Diagnostic list	100
10.4.1	Defining the tag name	58	12.8	Event logbook	100
10.5	Advanced settings	59	12.8.1	Event history	100
10.5.1	Setting the system units	60	12.8.2	Filtering the event logbook	101
10.5.2	Configuring the current output	61	12.8.3	Overview of information events	101
10.5.3	Configuring the pulse/frequency/ switch output	63	12.9	Resetting the measuring device	102
10.5.4	Configuring the status input	69	12.10	Device information	102
10.5.5	Configuring the output conditioning	70	12.11	Firmware history	103
10.5.6	Configuring the low flow cut off	70	13	Maintenance	104
10.5.7	Configuring the totalizer	71	13.1	Maintenance tasks	104
10.5.8	Carrying out additional display configurations	71	13.1.1	Exterior cleaning	104
10.5.9	Partly filled pipe detection	73	13.1.2	Interior cleaning	104
10.5.10	Performing in-situ adjustment	74	13.2	Measuring and test equipment	104
10.6	Configuration management	77	13.3	Endress+Hauser services	104
10.6.1	Function scope of "Configuration management" parameter"	78	14	Repair	105
10.7	Simulation	78	14.1	General notes	105
10.8	Protecting settings from unauthorized access	80	14.2	Spare parts	105
10.8.1	Write protection via access code	80	14.3	Endress+Hauser services	105
10.8.2	Write protection via write protection switch	81	14.4	Return	105
11	Operation	83	14.5	Disposal	105
11.1	Reading device locking status	83	14.5.1	Removing the measuring device	105
11.2	Adjusting the operating language	83	14.5.2	Disposing of the measuring device ..	106
11.3	Configuring the display	83	15	Accessories	107
11.4	Reading measured values	84	15.1	Device-specific accessories	107
11.4.1	Process variables	84	15.1.1	For the transmitter	107
11.4.2	Totalizer	84	15.1.2	For the sensor	107
11.4.3	Input values	85	15.2	Communication-specific accessories	108
11.4.4	Output values	85	15.3	Service-specific accessories	109
11.5	Adapting the measuring device to the process conditions	86	15.4	System components	109
11.6	Performing a totalizer reset	86	16	Technical data	110
11.6.1	Function scope of "Control Totalizer" parameter	87	16.1	Application	110
11.6.2	Function scope of "Reset all totalizers" parameter	87	16.2	Function and system design	110
11.7	Showing data logging	87	16.3	Input	110
12	Diagnostics and troubleshooting ...	89	16.4	Output	112
12.1	General troubleshooting	89	16.5	Power supply	114
12.2	Diagnostic information on local display	91	16.6	Performance characteristics	115
12.2.1	Diagnostic message	91	16.7	Installation	116
12.2.2	Calling up remedial measures	94	16.8	Environment	116
12.3	Diagnostic information in FieldCare	94	16.9	Process	117
12.3.1	Diagnostic options	94	16.10	Mechanical construction	118
12.3.2	Calling up remedial measures	96	16.11	Operability	122
			16.12	Certificates and approvals	123
			16.13	Accessories	124
			16.14	Documentation	124
			17	Appendix	125
			17.1	Overview of the operating menu	125
			17.1.1	Main menu	125

17.1.2 "Operation" menu	125
17.1.3 "Setup" menu	125
17.1.4 "Diagnostics" menu	131
17.1.5 "Expert" menu	133
Index	143





1 Document information

1.1 Document function





These Operating Instructions contain all the information that is required in various phases of the life cycle of the device: from product identification, incoming acceptance and storage, to mounting, connection, operation and commissioning through to troubleshooting, maintenance and disposal.

1.2 Symbols used





1.2.1 Safety symbols

Symbol	Meaning
 A0011189-EN	DANGER! This symbol alerts you to a dangerous situation. Failure to avoid this situation will result in serious or fatal injury.
 A0011190-EN	WARNING! This symbol alerts you to a dangerous situation. Failure to avoid this situation can result in serious or fatal injury.
 A0011191-EN	CAUTION! This symbol alerts you to a dangerous situation. Failure to avoid this situation can result in minor or medium injury.
 A0011192-EN	NOTE! This symbol contains information on procedures and other facts which do not result in personal injury.









1.2.2 Electrical symbols

Symbol	Meaning
 A0011197	Direct current A terminal to which DC voltage is applied or through which direct current flows.
 A0011198	Alternating current A terminal to which alternating voltage (sine-wave) is applied or through which alternating current flows.
 A0011200	Ground connection A grounded terminal which, as far as the operator is concerned, is grounded via a grounding system.
 A0011199	Protective ground connection A terminal which must be connected to ground prior to establishing any other connections.
 A0011201	Equipotential connection A connection that has to be connected to the plant grounding system: This may be a potential equalization line or a star grounding system depending on national or company codes of practice.

1.2.3 Tool symbols



Symbol	Meaning
 A0013442	Torx screwdriver
 A0011220	Flat blade screwdriver
 A0011219	Phillips head screwdriver
 A0011221	Allen key
 A0011222	Hexagon wrench

1.2.4 Symbols for certain types of information

Symbol	Meaning
 A0011182	Allowed Indicates procedures, processes or actions that are allowed.
 A0011183	Preferred Indicates procedures, processes or actions that are preferred.
 A0011184	Forbidden Indicates procedures, processes or actions that are forbidden.
 A0011193	Tip Indicates additional information.
 A0011194	Reference to documentation Refers to the corresponding device documentation.
 A0011195	Reference to page Refers to the corresponding page number.
 A0011196	Reference to graphic Refers to the corresponding graphic number and page number.
1, 2, 3, ...	Series of steps
✓	Result of a sequence of actions
 A0013562	Help in the event of a problem



1.2.5 Symbols in graphics

Symbol	Meaning
1, 2, 3, ...	Item numbers
1, 2, 3, ...	Series of steps
A, B, C, ...	Views
A-A, B-B, C-C, ...	Sections
 A0013441	Flow direction

Symbol	Meaning
 A0011187	Hazardous area Indicates a hazardous area.
 A0011188	Safe area (non-hazardous area) Indicates the non-hazardous area.

1.3 Documentation

-  For an overview of the scope of the associated Technical Documentation, refer to the following:
- The CD-ROM provided for the device (depending on the device version, the CD-ROM might not be part of the delivery!)
 - The *W@M Device Viewer* : Enter the serial number from the nameplate (www.endress.com/deviceviewer)
 - The *Endress+Hauser Operations App*: Enter the serial number from the nameplate or scan the 2-D matrix code (QR code) on the nameplate.

-  For a detailed list of the individual documents along with the documentation code (→  124)

1.3.1 Standard documentation

Document type	Purpose and content of the document
Technical Information	Planning aid for your device The document contains all the technical data on the device and provides an overview of the accessories and other products that can be ordered for the device.
Brief Operating Instructions	Guide that takes you quickly to the 1st measured value The Brief Operating Instructions contain all the essential information from incoming acceptance to initial commissioning.

1.3.2 Supplementary device-dependent documentation

Additional documents are supplied depending on the device version ordered: Always comply strictly with the instructions in the supplementary documentation. The supplementary documentation is an integral part of the device documentation.

1.4 Registered trademarks

HART®

Registered trademark of the HART Communication Foundation, Austin, USA

KALREZ®, VITON®

Registered trademarks of DuPont Performance Elastomers L.L.C., Wilmington, DE USA

Applicator®, FieldCare®, Field Xpert™, HistoROM®, Heartbeat Technology™

Registered or registration-pending trademarks of the Endress+Hauser Group

2 Basic safety instructions

2.1 Requirements for the personnel

The personnel for installation, commissioning, diagnostics and maintenance must fulfill the following requirements:

- ▶ Trained, qualified specialists must have a relevant qualification for this specific function and task
- ▶ Are authorized by the plant owner/operator
- ▶ Are familiar with federal/national regulations
- ▶ Before beginning work, the specialist staff must have read and understood the instructions in the Operating Instructions and supplementary documentation as well as in the certificates (depending on the application)
- ▶ Following instructions and basic conditions

The operating personnel must fulfill the following requirements:

- ▶ Being instructed and authorized according to the requirements of the task by the facility's owner-operator
- ▶ Following the instructions in these Operating Instructions

2.2 Designated use

Application and media

The measuring device described in these Operating Instructions is intended only for flow measurement of liquids.

Measuring devices for use in hazardous areas, in hygienic applications or in applications where there is an increased risk due to process pressure, are labeled accordingly on the nameplate.

To ensure that the measuring device remains in proper condition for the operation time:

- ▶ Only use the measuring device in full compliance with the data on the nameplate and the general conditions listed in the Operating Instructions and supplementary documentation.
- ▶ Based on the nameplate, check whether the ordered device is permitted for the intended use in the hazardous area (e.g. explosion protection, pressure vessel safety).
- ▶ Use the measuring device only for media against which the process-wetted materials are adequately resistant.
- ▶ If the measuring device is not operated at atmospheric temperature, compliance with the relevant basic conditions specified in the device documentation provided (on the CD-ROM) is absolutely essential.

Incorrect use

Non-designated use can compromise safety. The manufacturer is not liable for damage caused by improper or non-designated use.

WARNING

Risk of injury if the process connection and sensor gland are opened under pressure.

- ▶ The process connection and the sensor gland should only be opened in an unpressurized state.

NOTICE

Penetration of dust and moisture when the transmitter housing is opened.

- ▶ Only open the transmitter housing briefly, ensuring that no dust or moisture enters the housing.

NOTICE**Danger of breakage of the sensor due to corrosive or abrasive fluids!**

- ▶ Verify the compatibility of the process fluid with the sensor material.
- ▶ Ensure the resistance of all fluid-wetted materials in the process.
- ▶ Keep within the specified pressure and temperature range.

Verification for borderline cases:

- ▶ For special fluids and fluids for cleaning, Endress+Hauser is glad to provide assistance in verifying the corrosion resistance of fluid-wetted materials, but does not accept any warranty or liability as minute changes in the temperature, concentration or level of contamination in the process can alter the corrosion resistance properties.

Residual risks

The external surface temperature of the housing can increase by max. 15 K due to the power consumption of the electronic components. Hot process fluids passing through the measuring device will further increase the surface temperature of the housing. The surface of the sensor, in particular, can reach temperatures which are close to the fluid temperature.

Possible burn hazard due to fluid temperatures!

- ▶ For elevated fluid temperature, ensure protection against contact to prevent burns.

2.3 Workplace safety

For work on and with the device:

- ▶ Wear the required personal protective equipment according to federal/national regulations.

For welding work on the piping:

- ▶ Do not ground the welding unit via the measuring device.

2.4 Operational safety

Risk of injury!

- ▶ Operate the device in proper technical condition and fail-safe condition only.
- ▶ The operator is responsible for interference-free operation of the device.

Conversions to the device

Unauthorized modifications to the device are not permitted and can lead to unforeseeable dangers.

- ▶ If, despite this, modifications are required, consult with Endress+Hauser.

Repair

To ensure continued operational safety and reliability,

- ▶ Carry out repairs on the device only if they are expressly permitted.
- ▶ Observe federal/national regulations pertaining to repair of an electrical device.
- ▶ Use original spare parts and accessories from Endress+Hauser only.

2.5 Product safety

This measuring device is designed in accordance with good engineering practice to meet state-of-the-art safety requirements, has been tested, and left the factory in a condition in which it is safe to operate.

It meets general safety standards and legal requirements. It also complies with the EC directives listed in the device-specific EC Declaration of Conformity. Endress+Hauser confirms this by affixing the CE mark to the device.

2.6 IT security

We only provide a warranty if the device is installed and used as described in the Operating Instructions. The device is equipped with security mechanisms to protect it against any inadvertent changes to the device settings.

IT security measures in line with operators' security standards and designed to provide additional protection for the device and device data transfer must be implemented by the operators themselves.

Endress+Hauser can be contacted to provide support in performing this task.

3 Product description

3.1 Product design

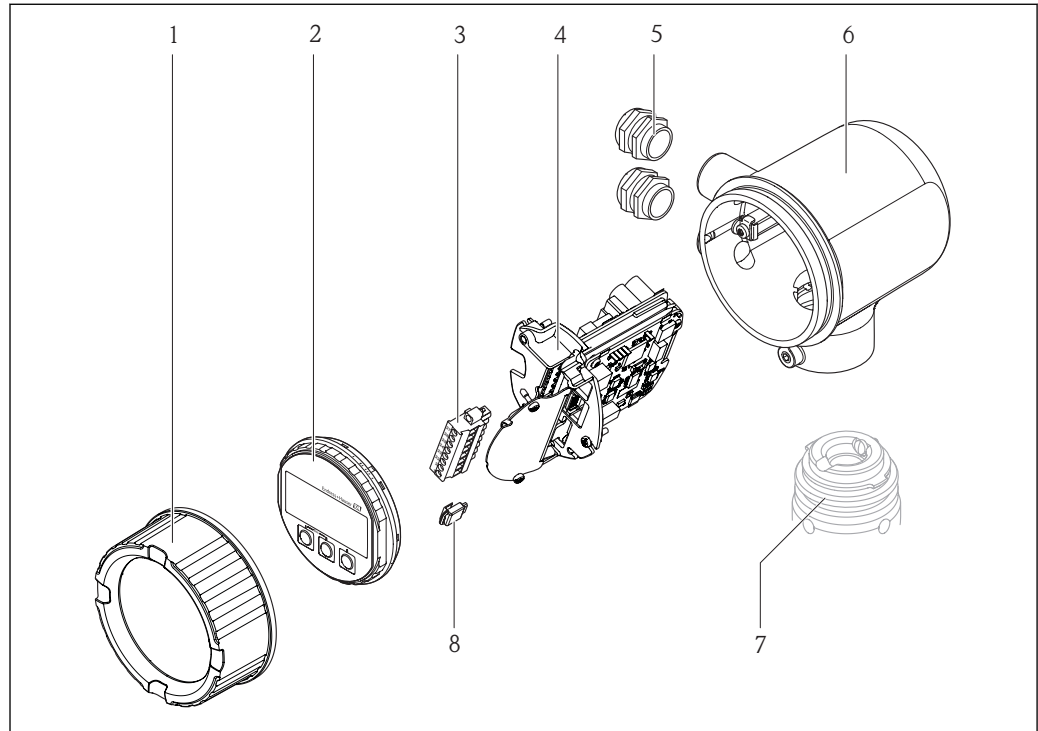

A0017196

- 1 Electronics compartment cover
- 2 Display module
- 3 Terminal block
- 4 Electronics module
- 5 Cable gland
- 6 Transmitter housing
- 7 Sensor
- 8 S-DAT

4 Incoming acceptance and product identification

4.1 Incoming acceptance

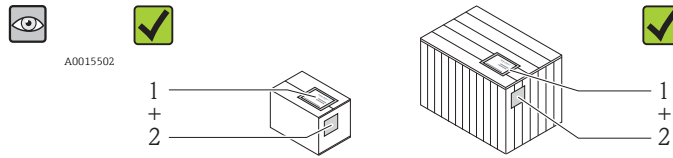

A0013843

Is the order code on the delivery note (1) identical to the order code on the product sticker (2)?

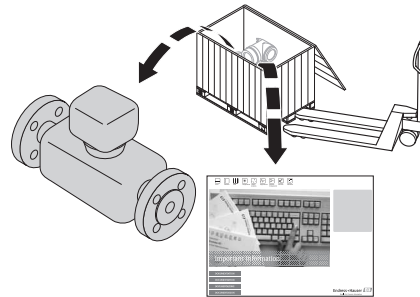

A0013695

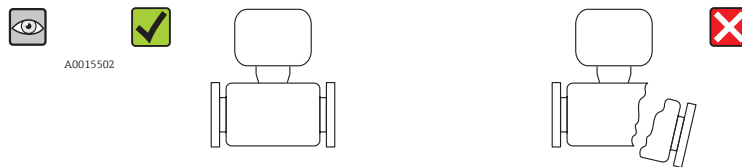

A0013698

Are the goods undamaged?

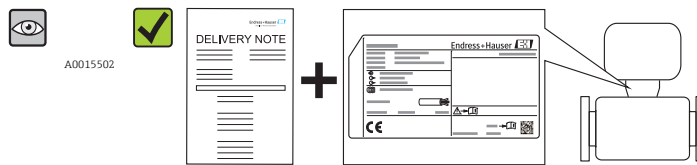

A0013699

Do the nameplate data match the ordering information on the delivery note?

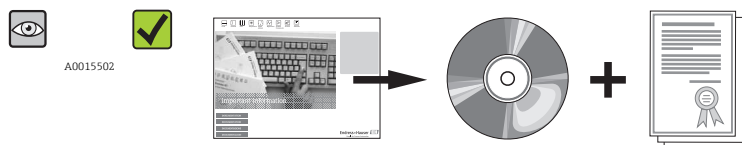

A0013697

Is the CD-ROM with the Technical Documentation and documents present?

 If one of the conditions does not comply, contact your Endress+Hauser distributor.

4.2 Product identification

The following options are available for identification of the measuring device:

- Nameplate specifications
- Order code with breakdown of the device features on the delivery note
- Enter serial numbers from nameplates in *W@M Device Viewer* (www.endress.com/deviceviewer): All information about the measuring device is displayed.

For an overview of the scope of the Technical Documentation provided, refer to the following:

- The chapters "Additional standard documentation on the device" (→  8) and "Supplementary device-dependent documentation"
- The *W@M Device Viewer* : Enter the serial number from the nameplate (www.endress.com/deviceviewer)

4.2.1 Transmitter nameplate

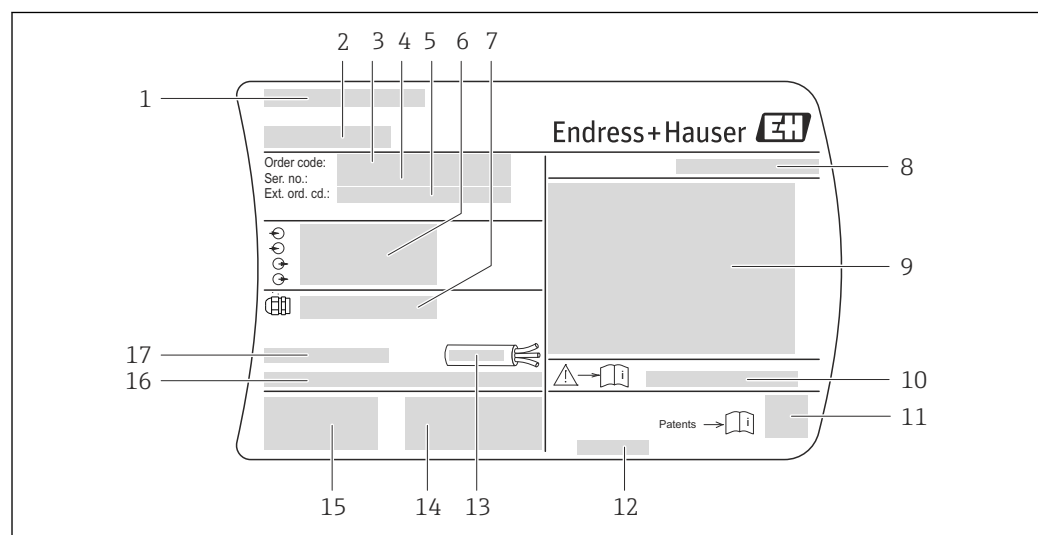

A0017229

 1 Example of a transmitter nameplate

- 1 Manufacturing location
- 2 Name of the transmitter
- 3 Order code
- 4 Serial number (Ser. no.)
- 5 Extended order code (Ext. ord. cd.)
- 6 Electrical connection data, e.g. available inputs and outputs, supply voltage
- 7 Type of cable glands
- 8 Degree of protection
- 9 Approval information for explosion protection
- 10 Document number of safety-related supplementary documentation
- 11 2-D matrix code
- 12 Manufacturing date: year-month
- 13 Permitted temperature range for cable
- 14 Additional information on version: certificates, approvals
- 15 CE mark, C-Tick
- 16 Firmware version (FW) and device revision (Dev.Rev.) from the factory
- 17 Permitted ambient temperature (T_a)

4.2.2 Sensor nameplate

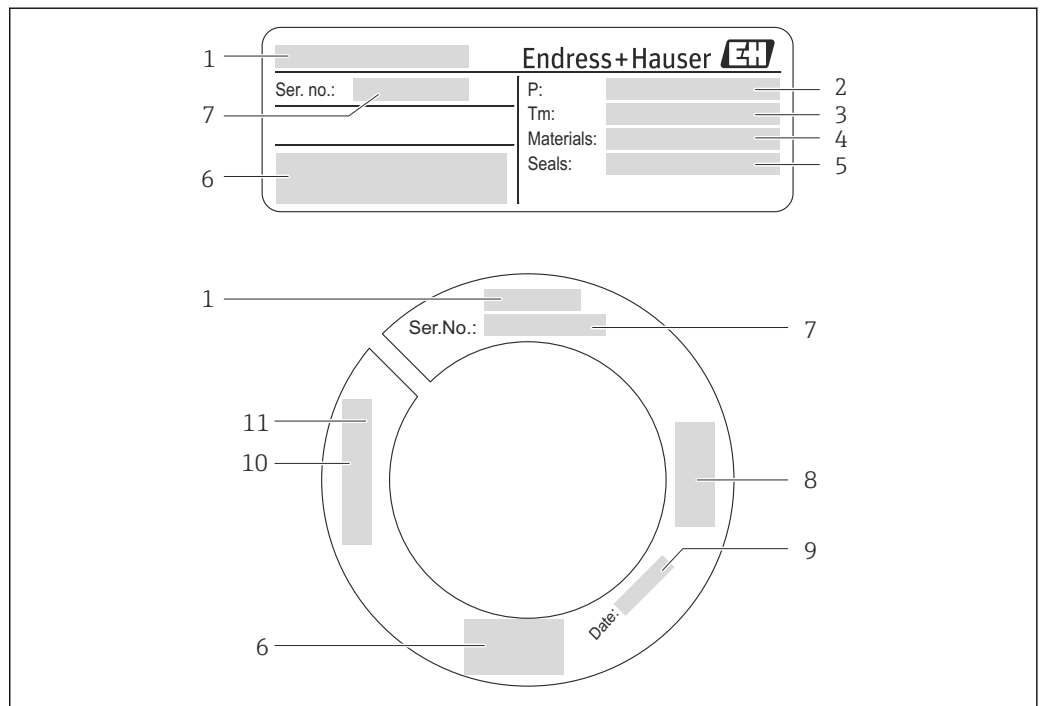

A0022136

 2 Example of a sensor nameplate

- 1 Name of the sensor
- 2 Process pressure range
- 3 Medium temperature range
- 4 Measuring tube material
- 5 Seal material
- 6 CE mark, C-Tick
- 7 Serial number (Ser. no.)
- 8 Approval information for Pressure Equipment Directive
- 9 Manufacturing date: year-month
- 10 Sensor length
- 11 Thread data

Additional sensor nameplate

Order code for "Additional approval", option LP "3A"

Order code for "Additional approval", option LT "EHEDG"

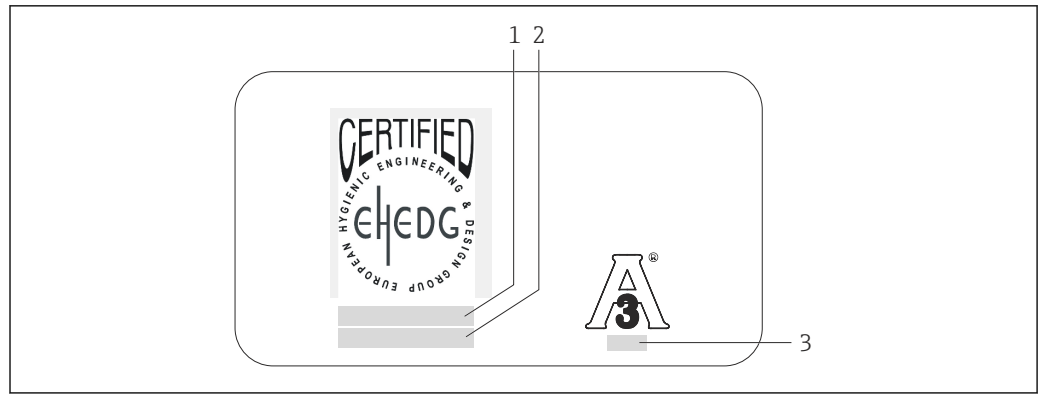



A0022298

3 Example of an additional sensor nameplate for 3A and/or EHEDG

- 1 Approval category (EHEDG)
- 2 Approval date (EHEDG)
- 3 Standard and release (3A)

4.2.3 Symbols on measuring device

Symbol	Meaning
 <small>A0011194</small>	WARNING! This symbol alerts you to a dangerous situation. Failure to avoid this situation can result in serious or fatal injury.
 <small>A0011194</small>	Reference to documentation Refers to the corresponding device documentation.
 <small>A0011199</small>	Protective ground connection A terminal which must be connected to ground prior to establishing any other connections.

5 Storage and transport

5.1 Storage conditions

Observe the following notes for storage:

- Store in the original packaging to ensure protection from shock.
- Do not remove the protection cap mounted on the transducer. It prevents mechanical damage and contamination in the measuring tube.
- Protect from direct sunlight to avoid unacceptably high surface temperatures.
- Select a storage location where moisture cannot collect in the measuring device as fungus and bacteria infestation can damage the lining.
- Storage temperature: -40 to +60 °C (-40 to +140 °F)
- Store in a dry and dust-free place.
- Do not store outdoors.

5.2 Transporting the product

Observe the following notes during transport:

- Transport the measuring device to the measuring point in the original packaging.
- Do not remove the protection cap mounted on the transducer. It prevents mechanical damage and contamination in the measuring tube.

5.3 Packaging disposal

All packaging materials are environmentally friendly and 100% recyclable:

- Measuring device secondary packaging: polymer stretch film that conforms to EC Directive 2002/95/EC (RoHS).
- Packaging:
 - Wood crate, treated in accordance with ISPM 15 standard, which is confirmed by the affixed IPPC logo.
 - or
 - Carton in accordance with European Packaging Directive 94/62EC; recyclability is confirmed by the affixed RESY symbol.
- Seaworthy packaging (optional): Wood crate, treated in accordance with ISPM 15 standard, which is confirmed by the affixed IPPC logo.
- Carrying and mounting hardware:
 - Disposable plastic pallet
 - Plastic straps
 - Plastic adhesive strips
- Dunnage: Paper cushion

6 Installation

6.1 Installation conditions

For mechanical reasons and to protect the pipe, support is recommended for heavy sensors (e.g. with a hot-tap retractable assembly).

6.1.1 Mounting position

Mounting location

NOTICE

Thermal measuring devices require a fully developed flow profile as a prerequisite for correct flow measurement.

For this reason, please pay attention to the following points and document sections when installing the device:

- ▶ Avoid flow disturbances, as the thermal measuring principle reacts sensitively to them.
- ▶ For mechanical reasons and to protect the pipe, support is recommended for heavy sensors (e.g. when installing a Hot tap extraction assembly).
- ▶ Maintain pre-defined device insertion depth of 8 mm (0.31 in).

Orientation



The direction of the arrow on the sensor body helps you to install the sensor according to the flow direction (direction of medium flow through the piping).

For detailed information on aligning with the flow direction: (→  23)

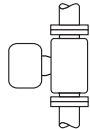
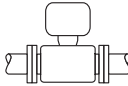
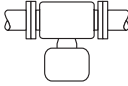
 Installation is generally not recommended in the event of high vibrations or unstable internal fittings.

	Orientation	Recommendation
Vertical orientation	 A0017337	✓ ¹⁾
Horizontal orientation, transmitter head up	 A0015589	✓✓
Horizontal orientation, transmitter head down	 A0015590	✓✓

1) Partially filled pipe detection is not possible in this orientation.

 For detailed information about partially filled pipe detection, refer to the "In-situ adjustment" chapter (→  74)

Pipes

The measuring device must be professionally installed, and the following points must be observed:

- Piping must be professionally welded.
- Seals must be sized correctly.
- Flanges and seals must be correctly aligned.
- The internal diameter of the pipe must be known. Deviations cause additional measuring uncertainty.
- Following installation, the pipe must be free from dirt and particles in order to avoid damage to the sensors.

Further information → ISO standard 14511



Insertion depth

Standard version

Order code for "Insertion Length", option L5 "110mm 4'" and L6 "330mm 13'"

NOTICE

Metal clamping ferrules undergo plastic deformation during the initial installation. As a result the insertion depth is fixed after initial installation and the clamping ferrules can no longer be replaced.

- ▶ Pay attention to information on preconditions and on determining the insertion depth.
- ▶ Check the insertion depth closely before tightening the clamping ferrules.

Preconditions

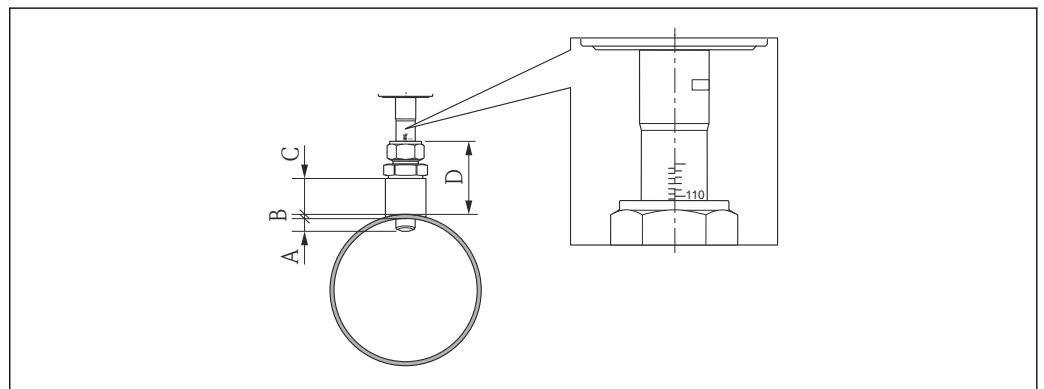

- A Fixed insertion depth 8 mm (0.31 in) \pm 2 mm (0.08 in)
- B Pipe wall thickness
- C Mounting boss height
- D Socket height (incl. coupling)

1. Determine pipe wall thickness (B).
2. Measure socket height (D).
 - ↳ **NOTE!** Mounting for the first time: Tighten thread adapter nut of the coupling hand tight.
3. Observe the maximum socket height D.

- ↳ **NOTE!** The pipe wall thickness (B) and socket height (D) may not exceed the permitted height.
B + D may not be greater than 102 mm (4.02 in).
- 4. If a mounting boss is used, pay attention to mounting boss height C.
 - ↳ **NOTE!** The pipe wall thickness (B) and mounting boss height (C) may not exceed the permitted height.
B + C may not be greater than 53 mm (2.09 in).

Determining the insertion depth before mounting for the first time

- ▶ For all nominal diameters: $8 + B + D - 1$

Controlling the insertion depth after mounting

- ▶ For all nominal diameters: $8 + B + D$

Hygienic version

Order code for "Insertion Length", option LH "Hygienic version"

Factory length

Order code for "Insertion Tube Material; Sensor", option BB "Stainless steel, factory length, 0.8µm, mechanically polished" and option BC "Stainless steel, factory length, 0.4µm, mechanically polished"

NOTICE

Certain dimensions are required to comply with the factory length.

- ▶ Pay attention to information in the dimension drawings.

Preconditions

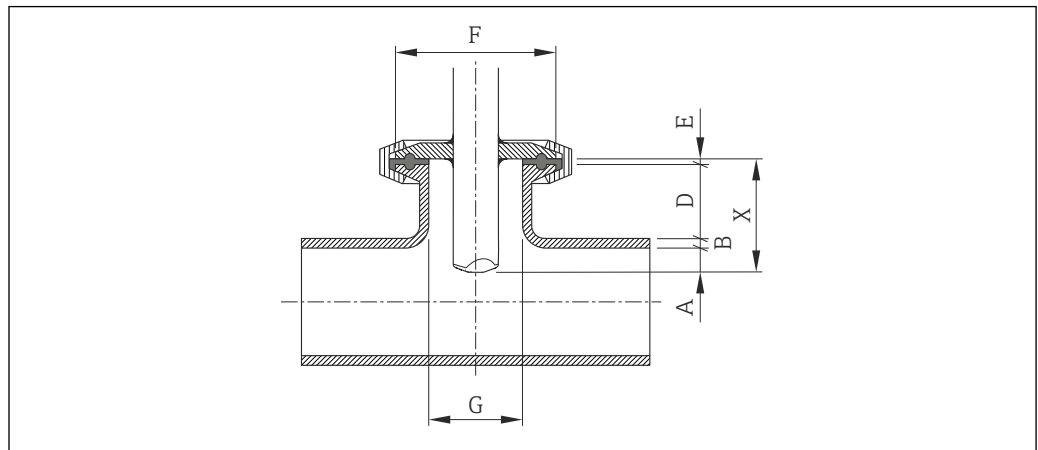

- A Fixed insertion depth 8 mm (0.31 in) ±2 mm (0.08 in)
- B Pipe wall thickness
- D Socket height
- E Seal thickness
- X Length
- G Socket internal diameter

1. Determine pipe wall thickness (B).
2. If a Tri-Clamp process connection is used, determine seal thickness (E).
 - ↳ **NOTE!** The socket internal diameter (G) may not be smaller than 25 mm (0.98 in).
3. If a conical coupling process connection with a self-centering sealing ring is used, determine seal thickness (E).

4. If an aseptic liner or a conical coupling process connection is used, set the seal thickness (E) to equal zero and do not take it into consideration.

Determining the socket height (D)

- ▶ For all nominal diameters: $32 - B - E$

NOTICE

For optimum cleaning it is recommended to:

- ▶ Have a large socket internal diameter (G).
- ▶ Keep the socket height (D) small.

Customized length

Order code for "Material of insertion pipe; sensor", option CB "..... mm customized length, 0.8µm, mechanically polished" and option CC "..... mm customized length, 0.4µm, mechanically polished"

Order code for "Material of insertion pipe; sensor", option CD "..... inch customized length, 0.8µm, mechanically polished" and option CE "..... inch customized length, 0.4µm, mechanically polished"

NOTICE

When ordering the customized length, it is necessary to declare the sensor length with the following decimal accuracies:

- ▶ **SI units (mm):** With a minimum of 1 decimal place. Example: 43.3 mm
- ▶ **US units (in):** With a minimum of 2 decimal places. Example: 17.05 in
- ▶ When ordering, a maximum of 3 decimal places can be declared.

NOTICE

Certain dimensions are required for determining the customized length.

- ▶ Pay attention to information in the dimension drawings.

Preconditions

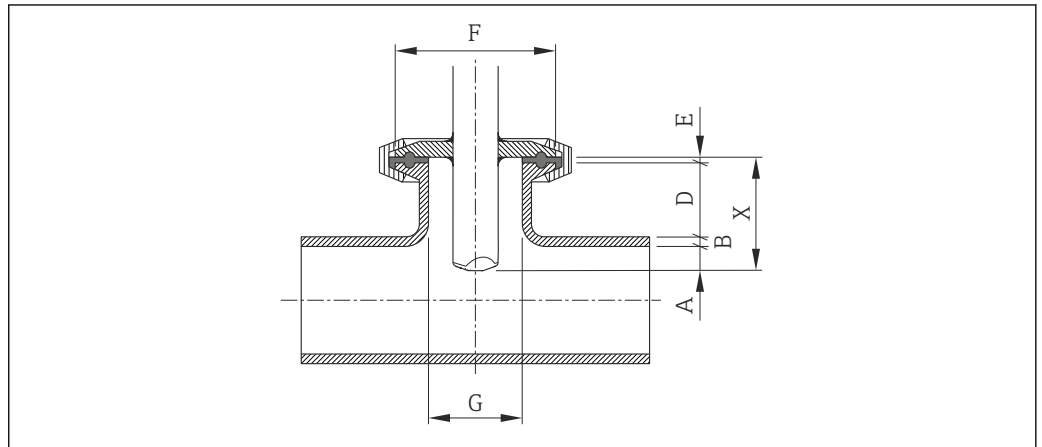

- A Fixed insertion depth 8 mm (0.31 in) ±2 mm (0.08 in)
- B Pipe wall thickness
- D Socket height
- E Seal thickness
- X Length
- G Socket internal diameter

1. Determine pipe wall thickness (B).
2. Measure socket height (D).
3. Observe the maximum socket height D.
 - ↳ **NOTE!** The pipe wall thickness (B) and socket height (D) may not exceed the permitted height.

$B + D$ may not be greater than 77 mm (3.03 in).

4. If a Tri-Clamp process connection is used, determine seal thickness (E).
 ↳ **NOTICE!** The pipe wall thickness (B), socket height (D) and sealing thickness (E) may not exceed the permitted height.

$B + D + E$ may not be greater than 77 mm (3.03 in).

5. If a conical coupling process connection with a self-centering sealing ring is used, determine seal thickness (E).
 ↳ **NOTE!** The pipe wall thickness (B), socket height (D) and sealing thickness (E) may not exceed the permitted height.

$B + D + E$ may not be greater than 77 mm (3.03 in).

6. If an aseptic liner or a conical coupling process connection is used, set the seal thickness (E) to equal zero and do not take it into consideration.
 ↳ **NOTE!** The pipe wall thickness (B) and socket height (D) may not exceed the permitted height.

$B + D$ may not be greater than 77 mm (3.03 in).

Determining the customized length

- For all nominal diameters: $8 + B + D + E$

Installation conditions for nipples

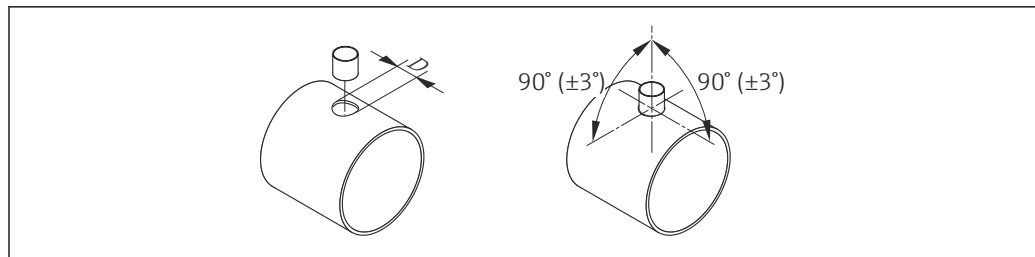

A0011843

- 4 Installation conditions for mounting bosses and threadolets

$D = 20.0 \text{ mm} \pm 0.5 \text{ mm} (0.79 \text{ in} \pm 0.02 \text{ in})$

- In the case of weld-in couplings with PEEK clamping ferrules, remove the clamping ferrules before you commence welding to avoid heat damage from the welding process.

Alignment with flow direction

Insertion version

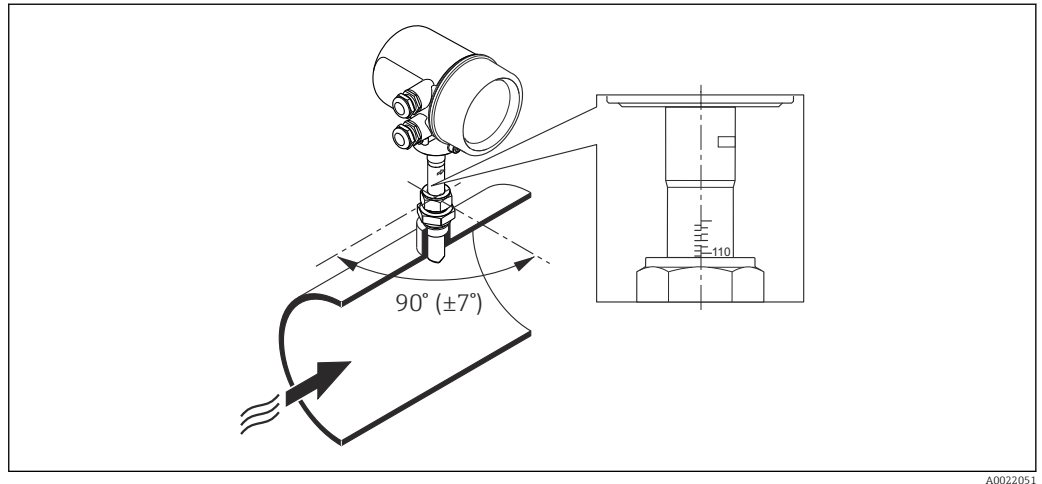

A0022051

1. Check and ensure that the sensor on the pipe is aligned at a 90° angle to the direction of flow (as shown in the graphic).
2. Rotate the sensor so that the arrow marking on the sensor body corresponds to the direction of flow.
3. Align the scale to the pipe axis.

Inlet and outlet runs

NOTICE

The thermal measuring principle is sensitive to disturbed flow conditions.

- ▶ As a general rule, install the measuring device as far away as possible from any flow disturbances. For further information → ISO 14511.
- ▶ If possible, install the sensor upstream from fittings such as valves, T-pieces, elbows etc.
- ▶ To attain the specified level of accuracy of the measuring device, the inlet and outlet runs mentioned below must be maintained at the very minimum.
- ▶ If there are several flow disturbances present, the longest specified inlet run must be maintained.

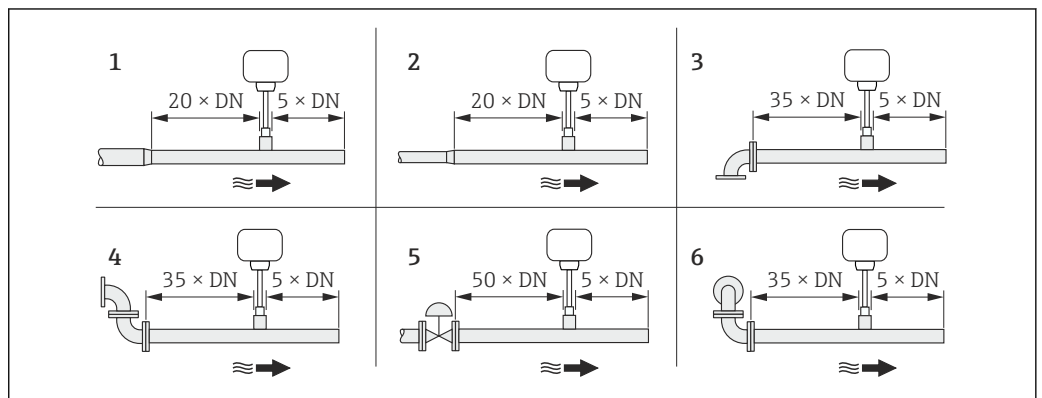

A0022381

- 1 reduction
- 2 expansion
- 3 90° elbow or T-section
- 4 $2 \times 90^\circ$ elbow
- 5 Control valve
- 6 $2 \times 90^\circ$ elbow 3-dimensional

Dimensions

 For the dimensions and installation lengths of the device, see the "Technical Information" document, "Mechanical construction" section

6.1.2 Requirements from environment and process

Ambient temperature range

Measuring device	-40 to +60 °C (-40 to +140 °F)
Local display	-20 to +60 °C (-4 to +140 °F), the readability of the display may be impaired at temperatures outside the temperature range.

- ▶ If operating outdoors:
Avoid direct sunlight, particularly in warm climatic regions.

System pressure

NOTICE

Depending on version:

Observe information on nameplate.

- ▶ Max. 40 bar g (580 psi g)

⚠ WARNING

If the coupling is opened incorrectly under full process pressure, the sensor will shoot out. Therefore it must be ensured that the sensor does not accelerate to a dangerous exit velocity.

- ▶ Use a safety chain for pressures > 4.5 bar (65.27 psi) in combination with PEEK clamping ferrules (→  107).

⚠ WARNING

The sensor is exposed to high temperatures.

Risk of burns from hot surfaces or leaking medium!

- ▶ Before commencing work: allow the system and measuring device to cool to a safe temperature.

Thermal insulation

The maximum possible thickness of the thermal insulation layer is:

Order code for "Insertion Length", option L5 "110mm 4": 100 mm (3.94 in)

The following is recommended for thicker insulation layers:

Order code for "Insertion Length", option L6 "330mm 13": 320 mm (12.6 in)

NOTICE

Electronics can overheat on account of thermal insulation!

- ▶ Observe maximum permitted insulation height of the transmitter neck so that the transmitter head is completely free.

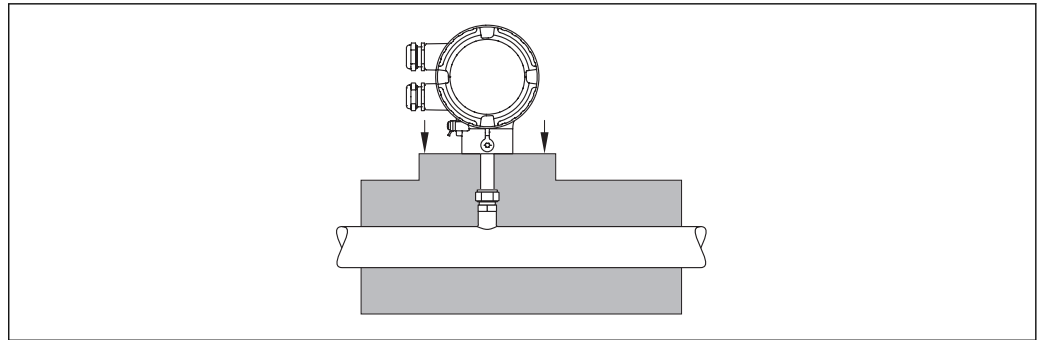

A0015763

6.2 Mounting the measuring device

6.2.1 Required tools

For transmitter

For turning the transmitter housing (in increments of 90°): Allen screw 4 mm (0.15 in)

For sensor

6.2.2 Preparing the measuring device

1. Remove all remaining transport packaging.
2. Remove stick-on label on the electronics compartment cover.

6.2.3 Mounting the measuring device

⚠ WARNING

Danger due to improper process sealing!

- ▶ Ensure that the gaskets are clean and undamaged.
- ▶ Ensure that the correct sealing material has been used (e.g. Teflon tape for NPT 3/4").
- ▶ Install the gaskets correctly.

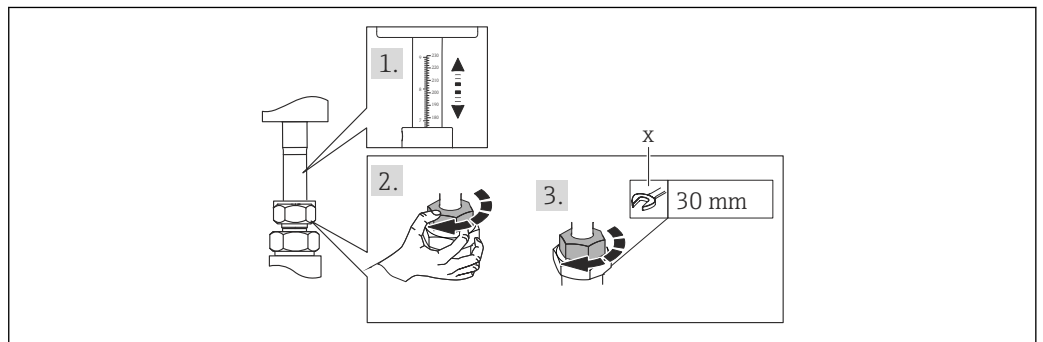

A0017331

5 Engineering unit mm (in)

x number of turns to tighten

1. Ensure that the direction of the arrow on the sensor matches the flow direction of the medium. Ensure the insertion depth (→ 19) and alignment (→ 23) are correct.
2. Tighten thread adapter nut hand tight.
3. Depending on the process connection:

Tighten thread adapter nut with x turns:

↳ For PEEK clamping ferrules continue with Step 4.

For metallic clamping ferrules continue with Step 5.

For hygienic process connections continue with Step 6.

4. For PEEK clamping ferrules:

Mounting for the first time: tighten thread adapter nut with $1\frac{1}{4}$ turns (→  25).

Repeat mounting: tighten thread adapter nut with 1 turn (→  25).

↳ **NOTE!** If strong vibrations can be expected, tighten the thread adapter nut with $1\frac{1}{2}$ turns (→  25) when mounting for the first time.

5. For metallic clamping ferrules:

Mounting for the first time: tighten thread adapter nut with $1\frac{1}{4}$ turns (→  25).

Repeat mounting: tighten thread adapter nut with $\frac{1}{4}$ turn (→  25).

6. For hygienic process connections:

Make sure the connection is aligned correctly and tighten the union nut or clamp for Tri-Clamp (not included in the delivery).

7. Install the measuring device or turn the transmitter housing so that the cable entries do not point upwards.

↳

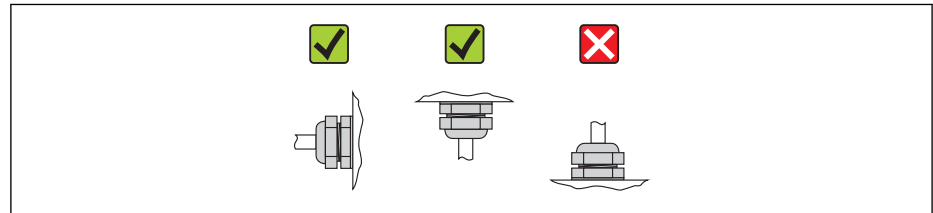

A0013964

6.2.4 Turning the transmitter housing

To provide easier access to the connection compartment or display module, the transmitter housing can be turned clockwise or counterclockwise to 4 indexed positions by a maximum of $2 \times 90^\circ$:

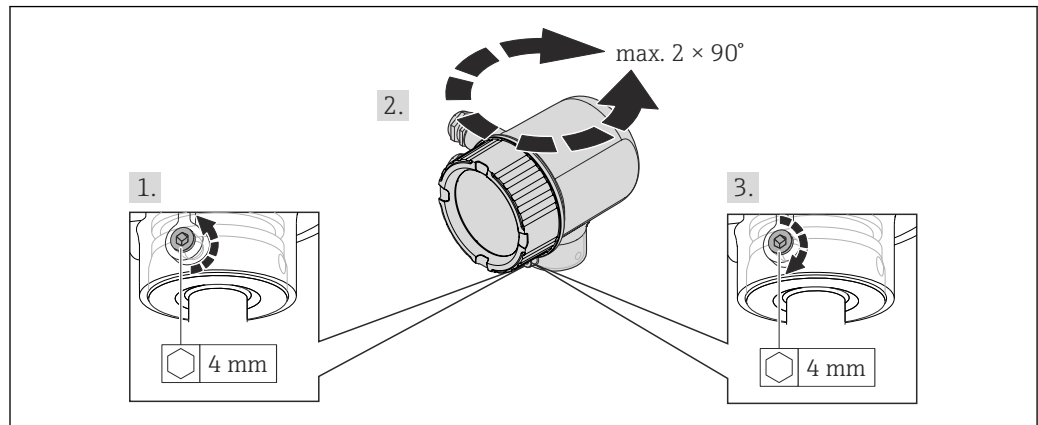

A0017227

 6 Engineering unit mm (in)

1. Unscrew the securing screw using an Allen key.
2. Rotate the housing in the desired direction.
3. Firmly tighten the securing screw.

6.2.5 Turning the display module

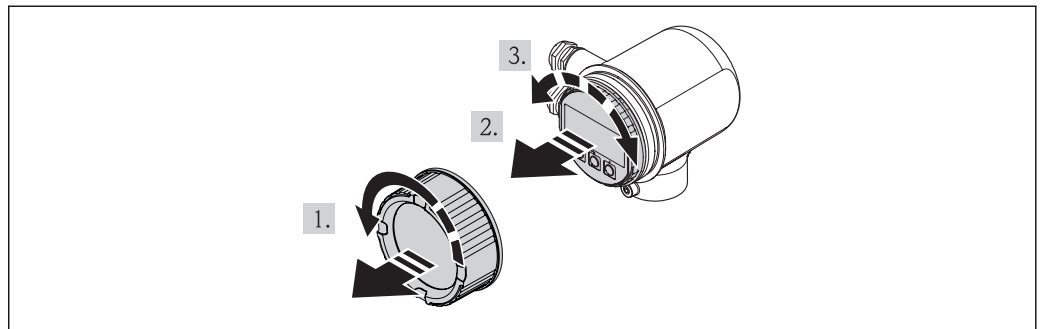

A0017228

1. Remove the cover of the electronics compartment.
2. Pull out the display module with a gentle rotational movement.
3. Turn the display module to the desired position: Max. $4 \times 90^\circ$ in each direction.
4. Feed the ribbon cable into the gap between the housing and main electronics module and plug the display module into the electronics compartment and turn it until it engages.
5. Screw the cover of the electronics compartment back on.

6.3 Post-installation check

Is the device undamaged (visual inspection)?	<input type="checkbox"/>
Does the measuring device conform to the measuring point specifications? For example: <ul style="list-style-type: none"> ▪ Process temperature (→ 117) ▪ Process pressure (refer to the chapter on "Material load curves" of the "Technical Information" document) ▪ Ambient temperature (→ 24) ▪ Measuring range (→ 110) 	<input type="checkbox"/>
Has the correct orientation for the sensor been selected (→ 18)? <ul style="list-style-type: none"> ▪ According to sensor type ▪ According to medium properties ▪ According to medium temperature ▪ According to process pressure 	<input type="checkbox"/>
Does the arrow on the sensor match the direction of flow of the medium through the piping (→ 18)?	<input type="checkbox"/>
Have sufficient inlet and outlet runs been provided upstream and downstream of the measuring point?	<input type="checkbox"/>
Correctly aligned in the direction of flow?	<input type="checkbox"/>
Is the device adequately protected from precipitation and direct sunlight?	<input type="checkbox"/>
Is the device protected against overheating?	<input type="checkbox"/>
Is the device protected against excessive vibrations?	<input type="checkbox"/>
Check liquid properties (e.g. purity, cleanness).	<input type="checkbox"/>
Are the measuring point identification and labeling correct (visual inspection)?	<input type="checkbox"/>

7 Electrical connection

7.1 Connection conditions

7.1.1 Required tools

- For cable entries: Use corresponding tools
- Wire stripper
- When using stranded cables: Crimping tool for ferrule
- Flat blade screwdriver ≤ 3 mm (0.12 in)

7.1.2 Requirements for connecting cable

The connecting cables provided by the customer must fulfill the following requirements.

Electrical safety

In accordance with applicable federal/national regulations.

Permitted temperature range

- -40 °C (-40 °F) to $\geq +80$ °C ($+176$ °F)
- Minimum requirement: cable temperature range \geq ambient temperature $+20$ K

Power supply cable

Standard installation cable is sufficient.

Signal cable

Current output

For 4-20 mA HART: Shielded cable recommended. Observe grounding concept of the plant.

Pulse/frequency/switch output, status input

Standard installation cable is sufficient.

Cable diameter

- Included cable glands: M20 \times 1.5 with cable $\phi 6$ to 12 mm (0.24 to 0.47 in)
- Wire cross-sections 0.5 to 1.5 mm² (21 to 16 AWG)

7.1.3 Terminal assignment

Transmitter

Connection version 4-20 mA HART, pulse/frequency/switch output, status input

Supply voltage

Order code for "Power supply"	Terminal numbers	
	1 (L+) ¹⁾	2 (L-) ¹⁾
Option D	DC 18 to 30 V	

1) Securely tighten the screws of the terminal. Recommended torque: 0.5 Nm.

Signal transmission

Order code for "Output, input"	Terminal numbers					
	Output 1		Output 2		Input	
	26 (+) ¹⁾	27 (-) ¹⁾	24 (+) ¹⁾	25 (-) ¹⁾	22 (+) ¹⁾	23 (-) ¹⁾
Option A	4-20 mA HART (active)		-		-	
Option B	4-20 mA HART (active)		Pulse/frequency/switch output (passive)		-	
Option K	-		Pulse/frequency/switch output (passive)		-	
Option Q	4-20 mA HART (active)		Pulse/frequency/switch output (passive)		Status input	

1) Securely tighten the screws of the terminal. Recommended torque: 0.5 Nm.

7.1.4 Pin assignment of the connector

4-20 mA HART with pulse/frequency/switch output

Supply voltage for 4-20 mA HART with pul./freq./switch output (on the device side)

<p style="text-align: center; font-size: small;">A0016809</p>	Pin	Assignment	Coding	Plug/socket	
	1	L+	DC24 V	A	Plug
	2	+	Status input		
	3	-	Status input		
	4	L-	DC24 V		
	5		Grounding/shielding		

4-20 mA HART with pulse/frequency/switch output (on the device side)

<p style="text-align: center; font-size: small;">A0016810</p>	Pin	Assignment	Coding	Plug/socket	
	1	+	4-20 mA HART (active)	A	Socket
	2	-	4-20 mA HART (active)		
	3	+	Pulse/frequency/switch output (passive)		
	4	-	Pulse/frequency/switch output (passive)		
	5		Grounding/shielding		

7.1.5 Requirements for the supply unit

Supply voltage

DC 24 V (18 to 30 V)

The power supply circuit must comply with SELV/PELV requirements.

Load

0 to 750 Ω, depending on the external supply voltage of the power supply unit

7.1.6 Preparing the measuring device

1. Remove dummy plug if present.

2. **NOTICE!** Insufficient sealing of the housing. Operational reliability of the measuring device could be defeated. Use suitable cable glands corresponding to the degree of protection.
If measuring device is delivered without cable glands:
Provide suitable cable gland for corresponding connecting cable.
3. If measuring device is delivered with cable glands:
Observe cable specification .

7.2 Connecting the measuring device

NOTICE

Limitation of electrical safety due to incorrect connection!

- ▶ Have electrical connection work carried out by correspondingly trained specialists only.
- ▶ Observe applicable federal/national installation codes and regulations.
- ▶ Comply with local workplace safety regulations.
- ▶ SELV/PELV-compliant 24 V DC (18 to 30 V) power supply.
- ▶ 4 to 20 mA HART active
- ▶ Maximum output values: DC 24V, 22 mA, load 0 to 750 Ω

7.2.1 Connecting the cables

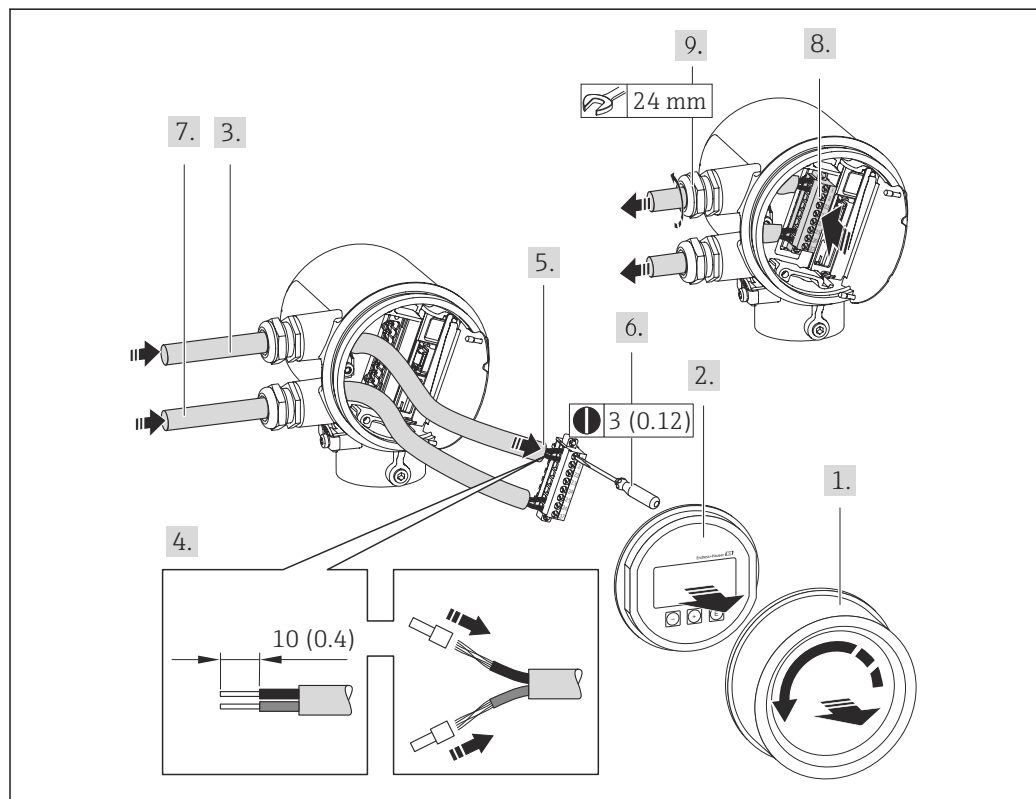

7 Engineering unit mm (in)

1. Unscrew the connection compartment cover.
2. Remove the display module.
3. Push the supply cable through the cable entry. To ensure tight sealing, do not remove the sealing ring from the cable entry.
4. Strip the cable and cable ends. In the case of stranded cables, also fit wire end ferrules.

5. Connect the cable in accordance with the terminal assignment . For HART communication: When connecting the cable shielding to the ground terminal, observe the grounding concept of the facility.
6. Firmly tighten the screws in the terminal block.
7. Perform the same steps for the signal cable as for the power supply cable.
8. Insert the terminal block into the electronics module.
9. Firmly tighten the cable glands.
10. **NOTICE!** Housing degree of protection voided due to insufficient sealing of the housing. Screw in the thread without using any lubricant. The threads on the cover are coated with a dry lubricant.
Reverse the removal procedure to reassemble the transmitter.

7.3 Ensuring the degree of protection

The measuring device fulfills all the requirements for the IP66 and IP67 (Type 4X enclosure) degree of protection.

To guarantee IP 66 and IP 67 degree of protection (Type 4X enclosure), carry out the following steps after the electrical connection:

1. Check whether the housing seals of the connection and electronics compartment are clean and inserted correctly. Dry, clean or replace the seals if necessary.
2. Tighten all housing screws and screw covers.
3. Firmly tighten the cable glands.
4. To ensure that moisture does not enter the cable entry, route the cable so that it loops down before the cable entry ("water trap").

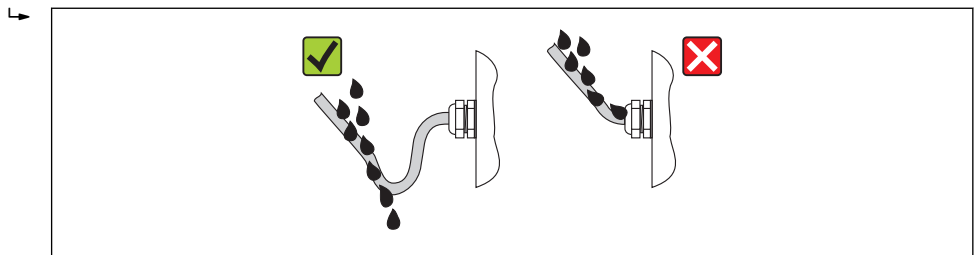

A0013960

5. Insert dummy plugs into unused cable entries.

7.4 Post-connection check

Are cables or the device undamaged (visual inspection)?	<input type="checkbox"/>
Are the power supply and signal cables correctly connected?	<input type="checkbox"/>
Does the supply voltage correspond to the specifications in the connection diagram?	<input type="checkbox"/>
Do the cables comply with the requirements ?	<input type="checkbox"/>
Do the cables have adequate strain relief? Are they routed securely?	<input type="checkbox"/>
Is the cable type route completely isolated? Without loops and cross-overs?	<input type="checkbox"/>
Are all the screw terminals firmly tightened?	<input type="checkbox"/>
Are all the cable glands installed, firmly tightened and leak-tight? Cable run with "water trap"? (→ 28)	<input type="checkbox"/>
Does the supply voltage match the specifications on the transmitter nameplate ?	<input type="checkbox"/>
Is the terminal assignment correct ?	<input type="checkbox"/>

If supply voltage is present, is the device ready for operation and do values appear on the display module?	<input type="checkbox"/>
Are all housing covers installed and firmly tightened?	<input type="checkbox"/>

8 Operation options

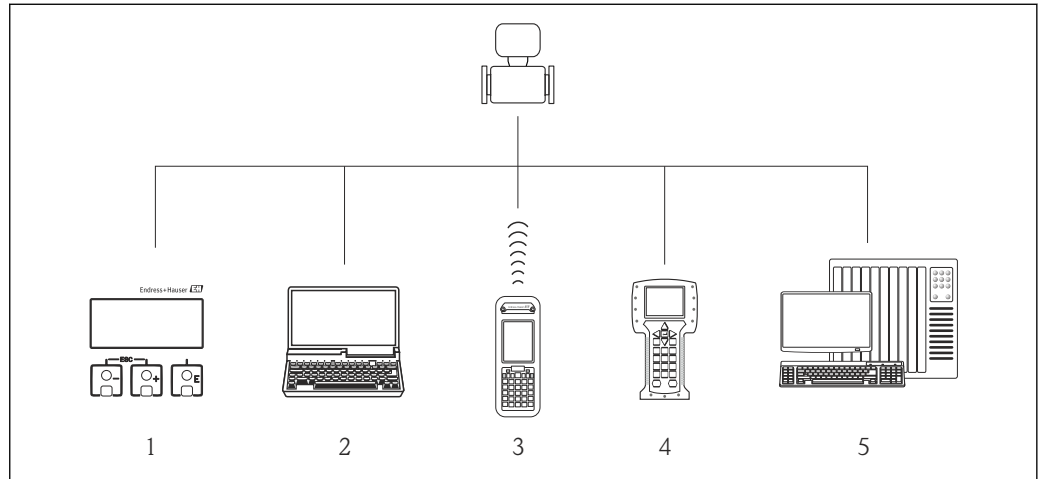

8.1 Overview of operation options



- 1 Local operation via display module
 2 Computer with operating tool (e.g. FieldCare, AMS Device Manager, SIMATIC PDM)
 3 Field Xpert SFX350 or SFX370
 4 Field Communicator 475
 5 Control system (e.g. PLC)

8.2 Structure and function of the operating menu

8.2.1 Structure of the operating menu

 For an overview of the operating menu with menus and parameters (→  125)

 For an overview of the operating menu for experts:

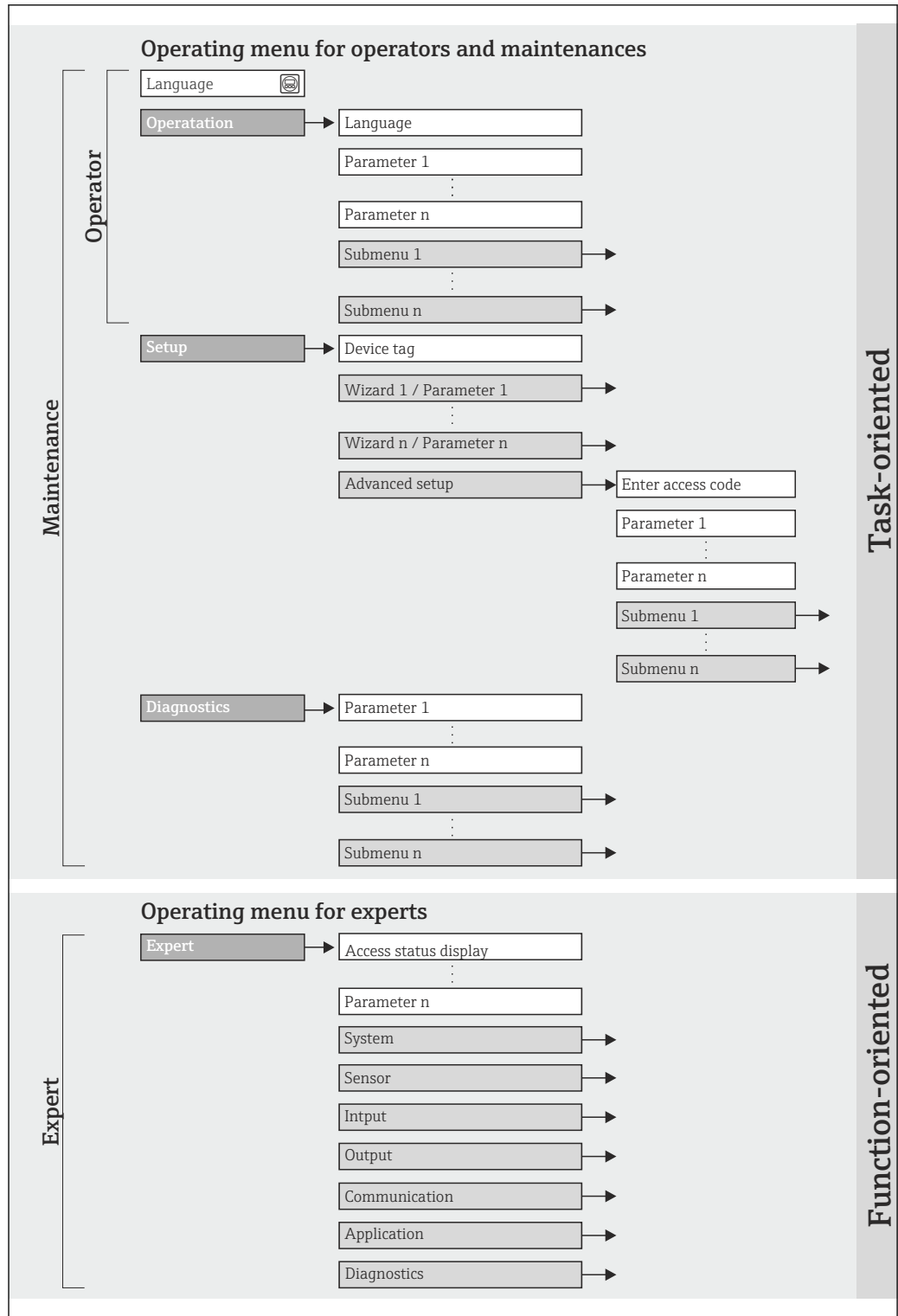

A0018237-EN

8 Schematic structure of the operating menu

8.2.2 Operating philosophy

The individual parts of the operating menu are assigned to certain user roles. Each user role corresponds to typical tasks within the device lifecycle.

Menu		User role and tasks	Content/meaning
Language	task-oriented	Role "Operator", "Maintenance" Tasks during operation: <ul style="list-style-type: none"> ▪ Configuring the measured value display ▪ Reading measured values 	Defining the operating language
Display/operat.			Configuration of the measured value display (e.g. display format, display contrast) Resetting and controlling totalizers
Setup		"Maintenance" role Commissioning: <ul style="list-style-type: none"> ▪ Configuration of the measurement ▪ Configuration of the outputs 	Parameters for quick commissioning: <ul style="list-style-type: none"> ▪ Entering the tag name ▪ Displaying the temperature currently measured ▪ Entering the inner diameter of the pipe ▪ Entering the installation factor ▪ Configuring the status input ▪ Configuring the outputs "Advanced setup" submenu: <ul style="list-style-type: none"> ▪ For more customized configuration of the measurement (adaptation to special measuring conditions) ▪ System units ▪ Configuring the outputs ▪ Configuring the status input ▪ Defining the output conditioning ▪ Configuring the low flow cut off ▪ Configuration of totalizer ▪ Configuring the display ▪ Conf. backup disp. ▪ Administration (define access code, reset measuring device)
Diagnostics	"Maintenance" role Fault elimination: <ul style="list-style-type: none"> ▪ Diagnostics and elimination of process and device errors ▪ Measured value simulation 	Contains all parameters for error detection and analyzing process and device errors: <ul style="list-style-type: none"> ▪ Diagnostic list Contains up to 5 currently pending diagnostic messages. ▪ Event logbook Contains up to 20 or 100 (order option) event messages that have occurred. ▪ Device information Contains information for identifying the device. ▪ Measured values Contains all current measured values. ▪ Data logging submenu (Order code for "Application package", option EA) Storage and visualization of up to 1000 measured values ▪ Simulation Is used to simulate measured values or output values. 	

Menu		User role and tasks	Content/meaning
Expert	function-oriented	<p>Tasks that require detailed knowledge of the function of the device:</p> <ul style="list-style-type: none"> ▪ Commissioning measurements under difficult conditions ▪ Optimal adaptation of the measurement to difficult conditions ▪ Detailed configuration of the communication interface ▪ Error diagnostics in difficult cases 	<p>Contains all the parameters of the device and makes it possible to access these parameters directly using an access code. The structure of this menu is based on the function blocks of the device:</p> <ul style="list-style-type: none"> ▪ System Contains all higher-order device parameters that do not pertain either to measurement or the measured value communication. ▪ Sensor Contains all parameters for configuring the measurement. Contains all parameters for in-situ adjustment. ▪ Input Contains all parameters for configuring the status input. ▪ Output Contains all parameters for configuring the analog current output and the pulse/frequency/switch output. ▪ Communication Contains all parameters for configuring the digital communication interface. ▪ Application Contains all parameters for configuring the functions that go beyond the actual measurement (e.g. totalizer). ▪ Diagnostics Contains all parameters for error detection and analyzing process and device errors and for device simulation.

8.3 Access to the operating menu via the local display

8.3.1 Operational display

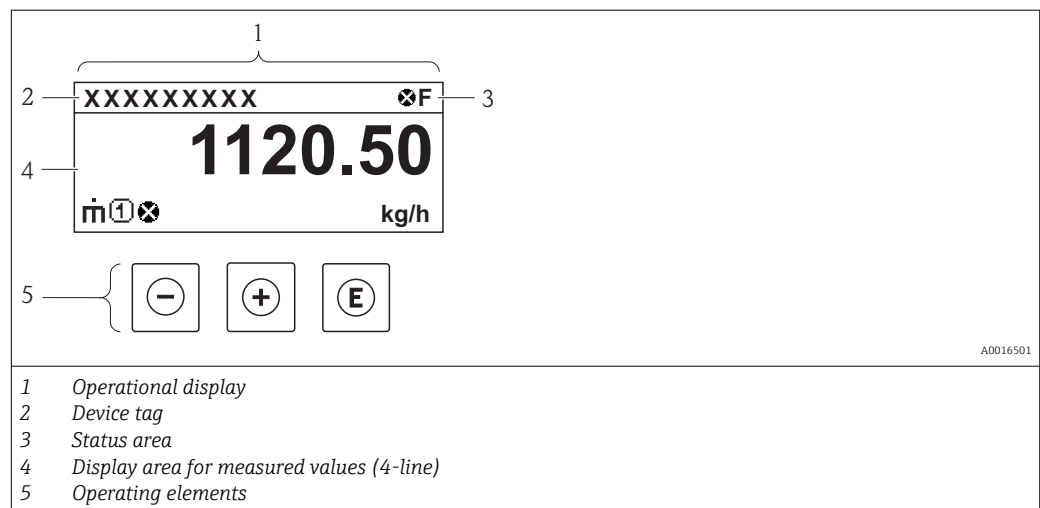



Status area

The following symbols appear in the status area of the operational display at the top right:

Status signals

Symbol	Meaning
F <small>A0013956</small>	Failure A device error has occurred. The measured value is no longer valid.
C <small>A0013959</small>	Function check The device is in service mode (e.g. during a simulation).
S <small>A0013958</small>	Out of specification The device is operated: <ul style="list-style-type: none"> ▪ Outside its technical specification limits (e.g. outside the process temperature range) ▪ Outside of the configuration carried out by the user (e.g. maximum flow in parameter 20 mA value)
M <small>A0013957</small>	Maintenance required Maintenance is required. The measured value is still valid.

Diagnostic behavior

Symbol	Meaning
 <small>A0013961</small>	Alarm Measurement is interrupted. The signal outputs and totalizers assume the defined alarm condition. A diagnostics message is generated .
 <small>A0013962</small>	Warning Measurement is resumed. The signal outputs and totalizers are not affected. A diagnostics message is generated .

Locking

Symbol	Meaning
 <small>A0013963</small>	Device locked The measuring device is hardware locked .

Communication

Symbol	Meaning
 <small>A0013965</small>	Communication via remote operation is active.

Display area



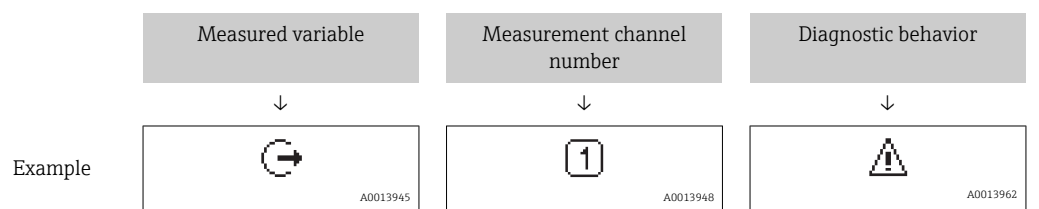

In the display area, each measured value is prefaced by certain symbol types for further description:



Appears only if a diagnostics event is present for this measured variable.

Measured variables

Symbol	Meaning
--------	---------

 <small>A0013711</small>	Volume flow
 <small>A0013710</small>	Mass flow
 <small>A0013947</small>	Temperature
 <small>A0013943</small>	Totalizer
 <small>A0013945</small>	Current output

Measurement channel numbers

Symbol	Meaning
 <small>A0016325</small>	Measurement channel 1 to 4
The measurement channel number is displayed only if more than one channel is present for the same measured variable type.	

Diagnostic behavior

The diagnostic behavior pertains to a diagnostic event that is relevant to the displayed measured variable. For more information about the symbols, refer to the "Status area" section .

 The number and display format of the measured values can be configured via the **"Format display" parameter**. "Operation" menu → Display → Format display

8.3.2 Navigation view

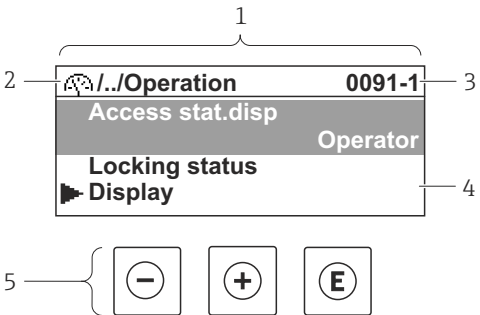
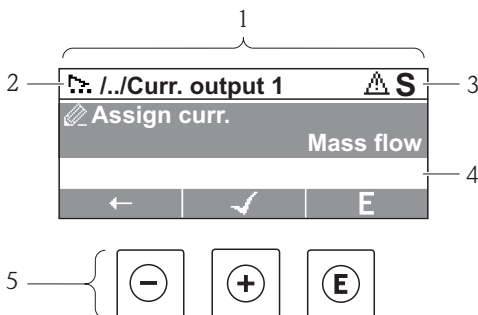
In the submenu	In the wizard
 <p style="text-align: right; font-size: small;">A0013993-EN</p>	 <p style="text-align: right; font-size: small;">A0017328-EN</p>
<p>1 Navigation view 2 Navigation path to current position 3 Status area 4 Display area for navigation 5 Operating elements</p>	

Navigation path

The navigation path - displayed at the top left in the navigation view - consists of the following elements:

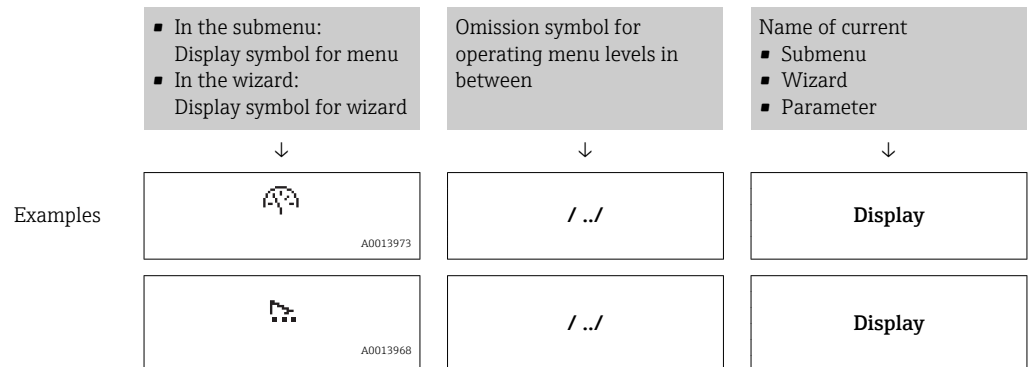



 For more information about the menu icons, refer to the "Display area" section

Status area

The following appears in the status area of the navigation view in the top right corner:





- In the submenu
 - The direct access code for the parameter you are navigating to (e.g. 0022-1)
 - If a diagnostic event is present, the diagnostic behavior and status signal
- In the wizard
 - If a diagnostic event is present, the diagnostic behavior and status signal

 For information on the diagnostic behavior and status signal





 For information on entering the direct access code and how this function works:

Display area

Menus

Symbol	Meaning
 A0013973	Operation Appears: <ul style="list-style-type: none"> In the menu next to the "Operation" selection At the left in the navigation path in the Operation menu
 A0013974	Setup Appears: <ul style="list-style-type: none"> In the menu next to the "Setup" selection At the left in the navigation path in the Setup menu
 A0013975	Diagnostics Appears: <ul style="list-style-type: none"> In the menu next to the "Diagnostics" selection At the left in the navigation path in the Diagnostics menu
 A0013966	Expert Appears: <ul style="list-style-type: none"> In the menu next to the "Expert" selection At the left in the navigation path in the Expert menu



Submenus, wizards, parameters

Symbol	Meaning
 A0013967	Submenu
 A0013968	Wizard
 A0013972	Parameters within a wizard  No display symbol exists for parameters in submenus.

Locking

Symbol	Meaning
 A0013963	Parameter locked When displayed in front of a parameter name, indicates that the parameter is locked. <ul style="list-style-type: none"> By a user-specific access code By the hardware write protection switch

Wizard operation

Symbol	Meaning
 A0013978	Switches to the previous parameter.
 A0013976	Confirms the parameter value and switches to the next parameter.
 A0013977	Opens the editing view of the parameter.



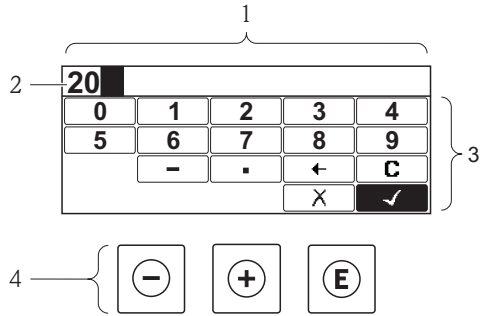
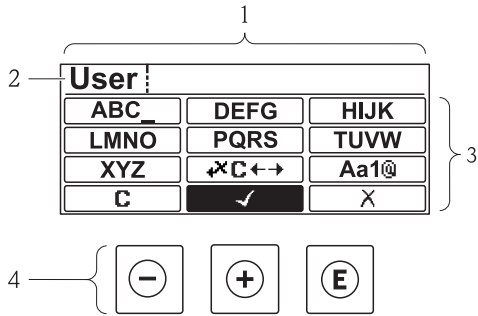



8.3.3 Editing view

Numeric editor	Text editor
 <p>A0013941</p>	 <p>A0013999</p>
<p>1 Editing view 2 Display area of the entered values 3 Input mask 4 Operating elements</p>	







Input mask

The following input symbols are available in the input mask of the numeric and text editor:

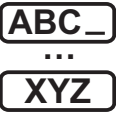

Numeric editor



Symbol	Meaning
 <small>A0013998</small>	Selection of numbers from 0 to 9.
 <small>A0016619</small>	Inserts decimal separator at the input position.
 <small>A0016620</small>	Inserts minus sign at the input position.
 <small>A0013985</small>	Confirms selection.
 <small>A0016621</small>	Moves the input position one position to the left.
 <small>A0013986</small>	Exits the input without applying the changes.
 <small>A0014040</small>	Clears all entered characters.

Text editor





Symbol	Meaning
 <small>A0013997</small>	Selection of letters from A to Z
 <small>A0013981</small>	Toggle <ul style="list-style-type: none"> ▪ Between upper-case and lower-case letters ▪ For entering numbers ▪ For entering special characters
 <small>A0013985</small>	Confirms selection.
 <small>A0013987</small>	Switches to the selection of the correction tools.
 <small>A0013986</small>	Exits the input without applying the changes.
 <small>A0014040</small>	Clears all entered characters.



Correction symbols under 

Symbol	Meaning
 <small>A0013989</small>	Clears all entered characters.
 <small>A0013991</small>	Moves the input position one position to the right.

 <small>A0013990</small>	Moves the input position one position to the left.
 <small>A0013988</small>	Deletes one character immediately to the left of the input position.

8.3.4 Operating elements

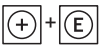
Key	Meaning
 <small>A0013969</small>	<p>Minus key</p> <p><i>In a menu, submenu</i> Moves the selection bar upwards in a choose list.</p> <p><i>With a Wizard</i> Confirms the parameter value and goes to the previous parameter.</p> <p><i>With a text and numeric editor</i> In the input mask, moves the selection bar to the left (backwards).</p>
 <small>A0013970</small>	<p>Plus key</p> <p><i>In a menu, submenu</i> Moves the selection bar downwards in a choose list.</p> <p><i>With a Wizard</i> Confirms the parameter value and goes to the next parameter.</p> <p><i>With a text and numeric editor</i> Moves the selection bar to the right (forwards) in an input screen.</p>
 <small>A0013952</small>	<p>Enter key</p> <p><i>For operational display</i></p> <ul style="list-style-type: none"> ▪ Pressing the key briefly opens the operating menu. ▪ Pressing the key for 2 s opens the context menu. <p><i>In a menu, submenu</i></p> <ul style="list-style-type: none"> ▪ Pressing the key briefly: <ul style="list-style-type: none"> - Opens the selected menu, submenu or parameter. - Starts the wizard. - If help text is open, closes the help text of the parameter. ▪ Pressing the key for 2 s for parameter: <ul style="list-style-type: none"> - If present, opens the help text for the function of the parameter. <p><i>With a Wizard</i> Opens the editing view of the parameter.</p> <p><i>With a text and numeric editor</i></p> <ul style="list-style-type: none"> ▪ Pressing the key briefly: <ul style="list-style-type: none"> - Opens the selected group. - Carries out the selected action. ▪ Pressing the key for 2 s confirms the edited parameter value.
 <small>A0013971</small>	<p>Escape key combination (press keys simultaneously)</p> <p><i>In a menu, submenu</i></p> <ul style="list-style-type: none"> ▪ Pressing the key briefly: <ul style="list-style-type: none"> - Exits the current menu level and takes you to the next higher level. - If help text is open, closes the help text of the parameter. ▪ Pressing the key for 2 s returns you to the operational display ("home position"). <p><i>With a Wizard</i> Exits the wizard and takes you to the next higher level.</p> <p><i>With a text and numeric editor</i> Closes the text or numeric editor without applying changes.</p>
 <small>A0013953</small>	<p>Minus/Enter key combination (press the keys simultaneously)</p> <p>Reduces the contrast (brighter setting).</p>

Key	Meaning
 <small>A0013954</small>	Plus/Enter key combination (press and hold down the keys simultaneously) Increases the contrast (darker setting).
 <small>A0013955</small>	Minus/Plus/Enter key combination (press the keys simultaneously) <i>For operational display</i> Enables or disables the keypad lock.

8.3.5 Opening the context menu

Using the context menu, the user can call up the following three menus quickly and directly from the measured value display:

- Setup
- Conf. backup disp.
- Simulation



Calling up and closing the context menu

The user is in the measured value display.

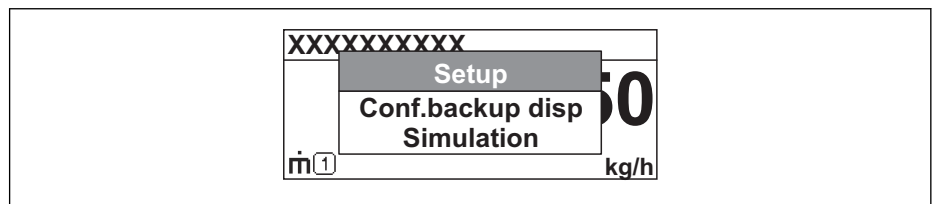

1. Press  for 2 s.
 ↳ The context menu opens.



A0014003-EN

2. Press  +  simultaneously.
 ↳ The context menu is closed and the measured value display appears.

Calling up the menu via the context menu

1. Open the context menu.
2. Press  to navigate to the desired menu.
3. Press  to confirm the selection.
 ↳ The selected menu opens.

8.3.6 Navigating and selecting from list

Different operating elements are used to navigate through the operating menu. The navigation path is displayed on the left in the header. Icons are displayed in front of the individual menus. These icons are also shown in the header during navigation.

i For an explanation of the navigation view with symbols and operating elements

Example: Setting the number of displayed measured values to "2 values"

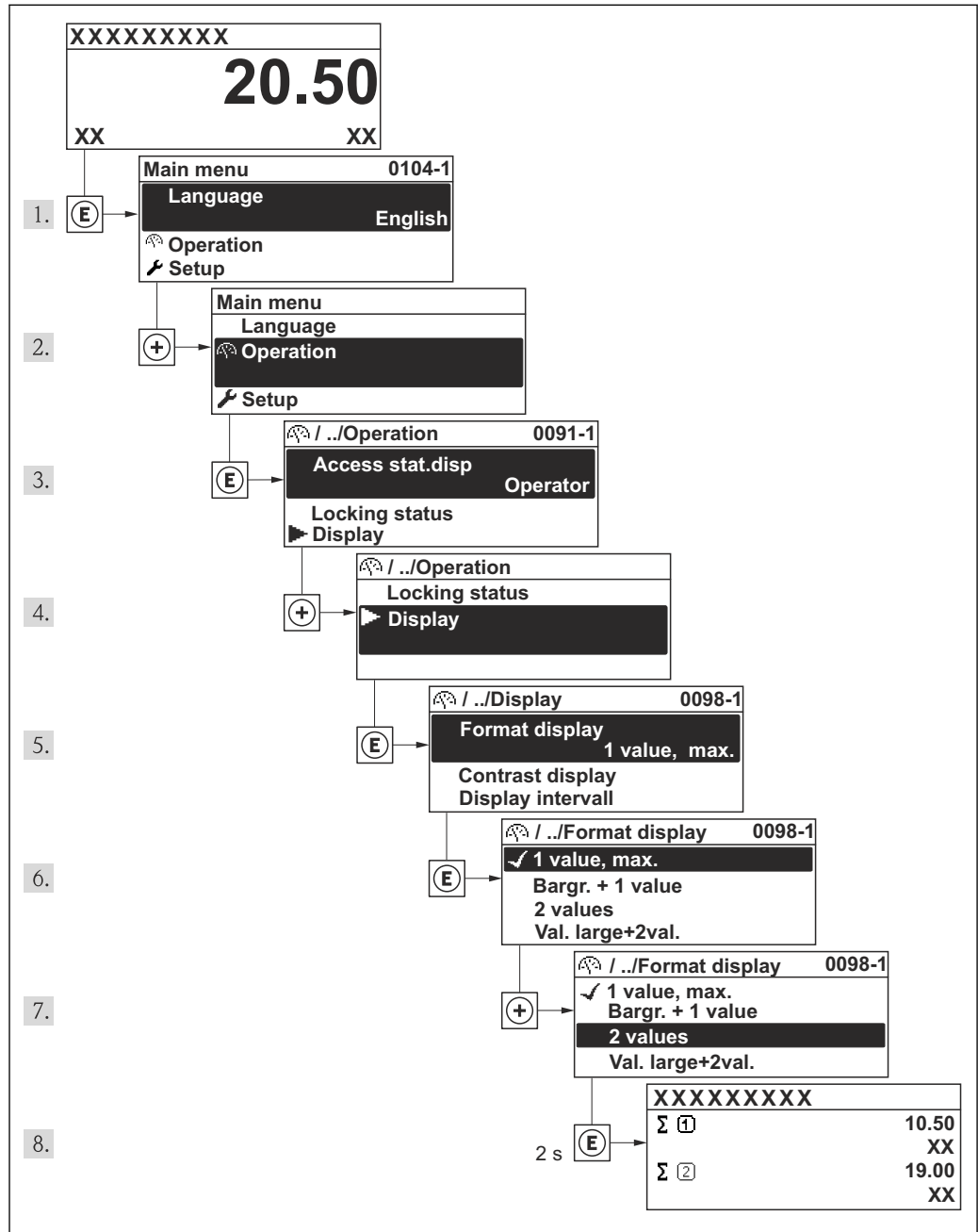

A0014010-EN

8.3.7 Calling the parameter directly

A parameter number is assigned to every parameter to be able to access a parameter directly via the onsite display. Entering this access code in the **Direct access** parameter calls up the desired parameter directly.

Navigation path

"Expert" menu → Direct access

The direct access code consists of a 4-digit number and the channel number, which identifies the channel of a process variable: e.g. 0914-1. In the navigation view, this appears on the right-hand side in the header of the selected parameter.

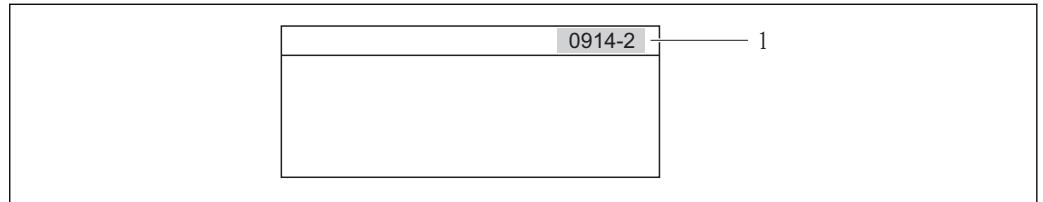



A0017223

1 Direct access code

Note the following when entering the direct access code:

- The leading zeros in the direct access code do not have to be entered.
Example: Input of "914" instead of "0914"
- If no channel number is entered, channel 1 is jumped to automatically.
Example: Input of "0914" → Parameter **Totalizer 1**
- If a different channel is jumped to: Enter the direct access code with the corresponding channel number.
Example: Input of "0914-2" → Parameter **Totalizer 2**

 For the direct access codes of the individual parameters (→  125)

8.3.8 Calling up help text

Help text is available for some parameters and can be called up from the navigation view. The help text provides a brief explanation of the parameter function and thereby supports swift and safe commissioning.

Calling up and closing the help text

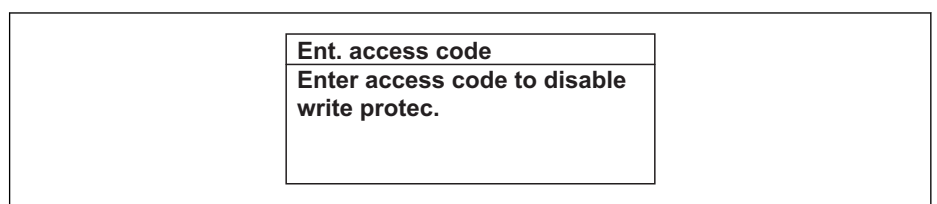

The user is in the navigation view and the selection bar is on a parameter.

1. Press  for 2 s.
↳ The help text for the selected parameter opens.



A0014002-EN

 9 Example: Help text for parameter "Enter access code"

2. Press  +  simultaneously.
↳ The help text is closed.

8.3.9 Changing the parameters

i For a description of the editing display - consisting of text editor and numeric editor - with symbols, for a description of the operating elements

Example: Changing the parameter "20 mA value" to 20 kg/s

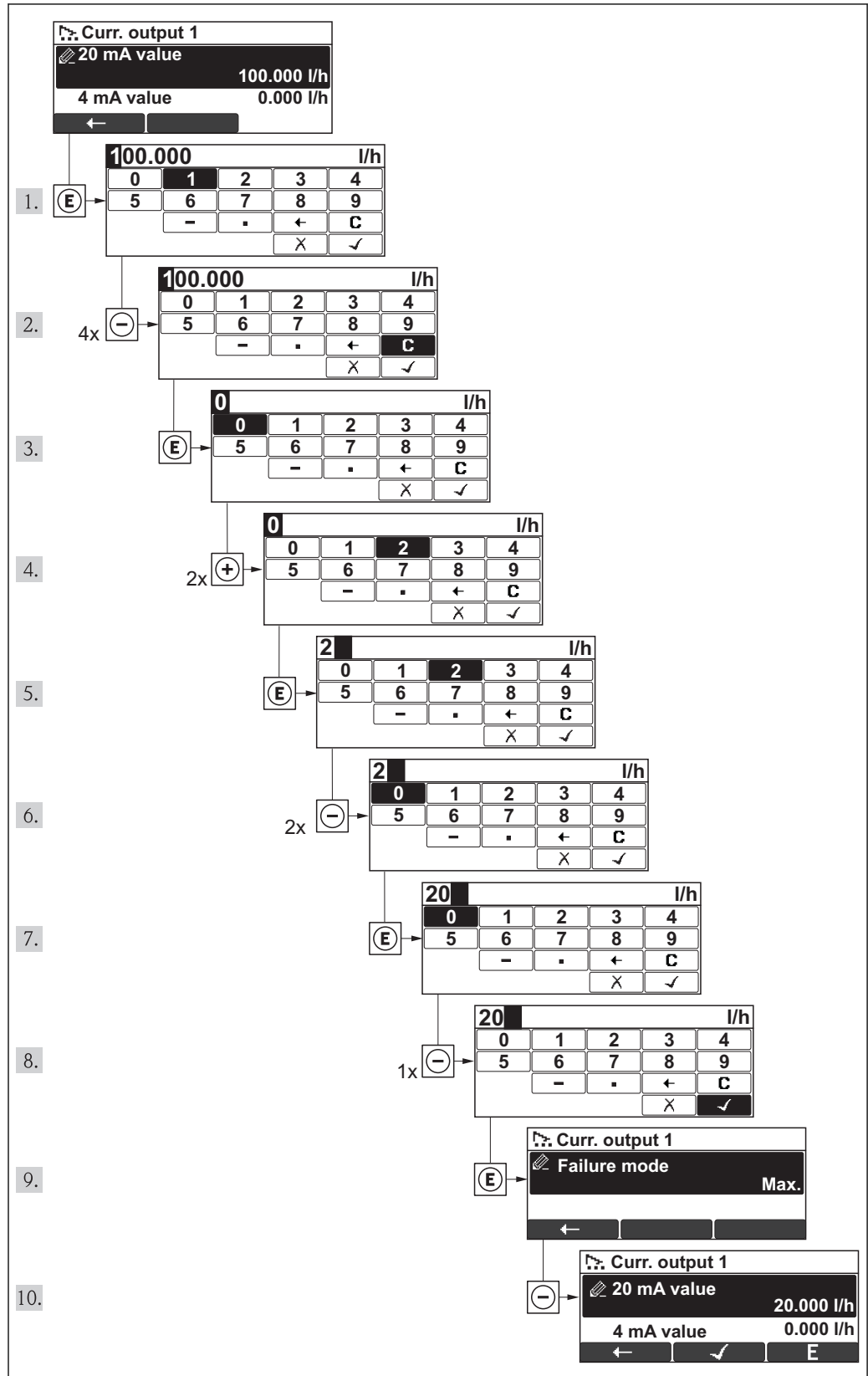

A0016332-EN

A message is displayed if the value entered is outside the permitted value range.

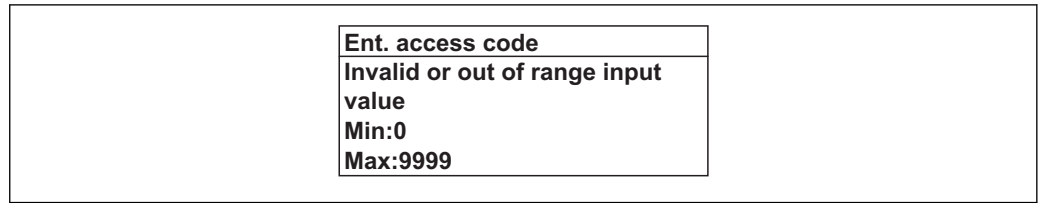

A0014049-EN

8.3.10 User roles and related access authorization

The two user roles "Operator" and "Maintenance" have different write access to the parameters if the customer defines a user-specific access code. This protects the device configuration via the local display from unauthorized access .

Access authorization to parameters

User role	Read access		Write access	
	Without access code (from the factory)	With access code	Without access code (from the factory)	With access code
Operator	✓	✓	✓	-- 1)
Maintenance	✓	✓	✓	✓

- 1) Despite the defined access code, certain parameters can always be modified and thus are excepted from the write protection, as they do not affect the measurement. Refer to the "Write protection via access code" section



If an incorrect access code is entered, the user obtains the access rights of the "Operator" role.

 The user role with which the user is currently logged on is indicated by the **Access status display** parameter. Navigation path: **Operation** menu → **Access status display** parameter

8.3.11 Disabling write protection via access code

If the -symbol appears on the local display in front of a parameter, the parameter is write-protected by a user-specific access code and its value cannot be changed at the moment using the local display .

The locking of the write access via local operation can be disabled by entering the customer-defined access code via the respective access option.

1. After you press , the input prompt for the access code appears.
2. Enter the access code.
 - ↳ The -symbol in front of the parameters disappears; all previously write-protected parameters are now re-enabled.

8.3.12 Enabling and disabling the keypad lock



The keypad lock makes it possible to block access to the entire operating menu via local operation. As a result, it is no longer possible to navigate through the operating menu or change the values of individual parameters. Users can only read the measured values on the operational display.

Local operation with mechanical push buttons (display module SD02)

 Display module SD02: order characteristic "Display; Operation", option C



The keypad lock is switched on and off in the same way:

Switching on the keypad lock

- ▶ The device is in the measured value display.
Press the  +  +  keys simultaneously.
 - ↳ The message **Keylock on** appears on the display: The keypad lock is switched on.

 If the user attempts to access the operating menu while the keypad lock is active, the message **Keylock on** appears.

Switching off the keypad lock

- ▶ The keypad lock is switched on.
Press the  +  +  keys simultaneously.
 - ↳ The message **Keylock off** appears on the display: The keypad lock is switched off.

8.4 Access to the operating menu via the operating tool

The structure of the operating menu in the operating tools is the same as for operation via the local display.

8.4.1 Connecting the operating tool

Via HART protocol

This communication interface is present in the following device version:

- Order code for "Output", option **A**: 4-20 mA HART
- Order code for "Output", option **B**: 4-20 mA HART, pulse/frequency/switch output
- Order code for "Output", option **Q**: 4-20 mA HART, pulse/frequency/switch output, status input

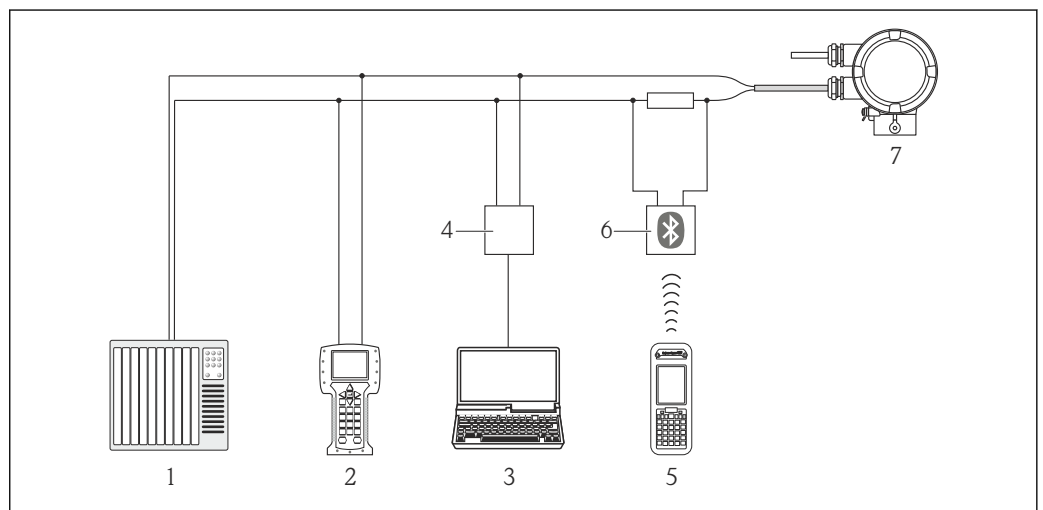

A0017373

10 Options for remote operation via HART protocol

- 1 Control system (e.g. PLC)
- 2 Field Communicator 475
- 3 Computer with operating tool (e.g. FieldCare, AMS Device Manager, SIMATIC PDM)
- 4 Commubox FXA195 (USB)
- 5 Field Xpert SFX350 or SFX370
- 6 VIATOR Bluetooth modem with connecting cable
- 7 Transmitter

Via service interface (CDI)

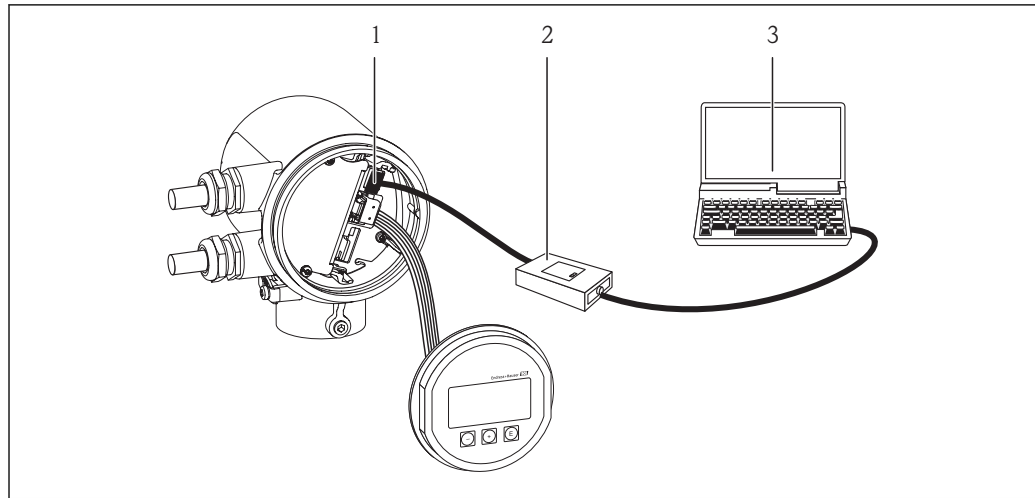

A0017253

- 1 Service interface (CDI) of the measuring device
- 2 Commubox FXA291
- 3 Computer with "FieldCare" operating tool with COM DTM "CDI Communication FXA291"

8.4.2 Field Xpert SFX350, SFX370

Function scope

Field Xpert SFX350 and SFX370 are mobile computers for commissioning and maintenance. They enable efficient device configuration and diagnostics for HART and FOUNDATION fieldbus devices in the **non-Ex area** (SFX350, SFX370) and the **Ex area** (SFX370).

 For details, see Operating Instructions BA01202S

Source for device description files

See data (→  53)

8.4.3 FieldCare

Function scope

FDT-based plant asset management tool from Endress+Hauser. It can configure all smart field devices in a system and helps you manage them. By using the status information, it is also a simple but effective way of checking their status and condition.

Access takes place via:

- HART protocol
- Service interface

Typical functions:

- Configuring parameters of transmitters
- Loading and saving device data (upload/download)
- Documentation of the measuring point
- Visualization of the measured value memory (line recorder) and event logbook

 For details, see Operating Instructions BA00027S and BA00059S

Source for device description files

See data (→ 53)

User interface

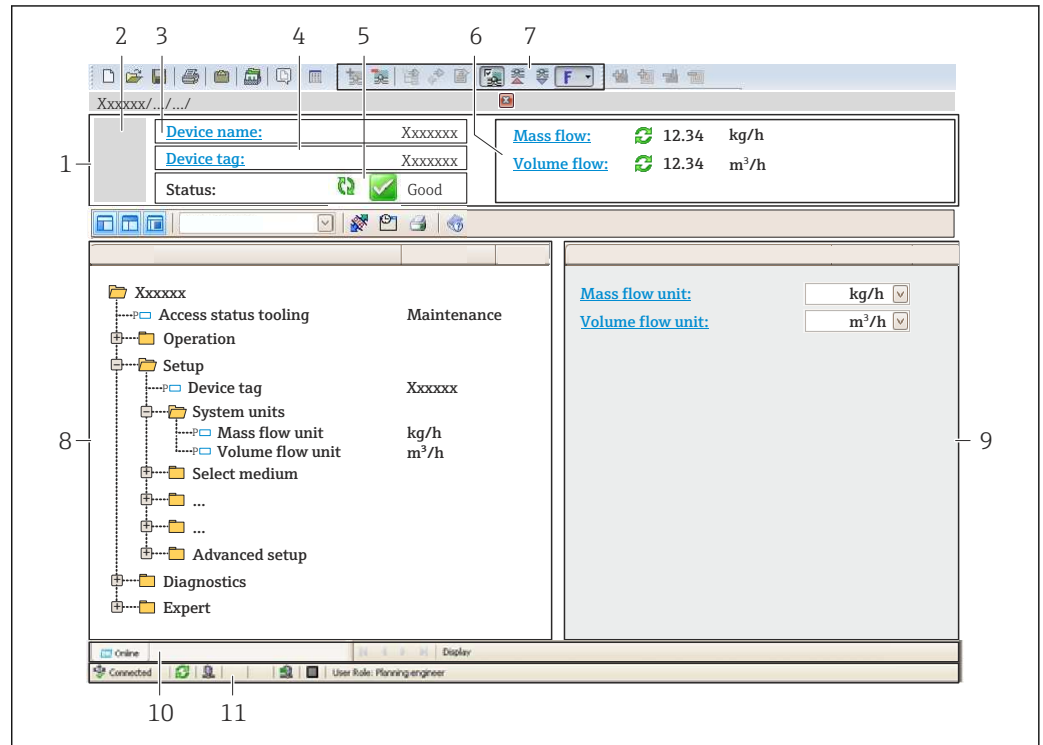

- 1 Header
- 2 Picture of device
- 3 Device name
- 4 Device tag
- 5 Status area with status signal
- 6 Display area for current measured values
- 7 Event list with additional functions such as save/load, events list and document creation
- 8 Navigation area with operating menu structure
- 9 Working area
- 10 Range of action
- 11 Status area

8.4.4 AMS Device Manager

Function scope

Program from Emerson Process Management for operating and configuring measuring devices via HART protocol.

Source for device description files

See data (→ 53)

8.4.5 SIMATIC PDM

Function scope

SIMATIC PDM is a standardized, manufacturer-independent program from Siemens for the operation, configuration, maintenance and diagnosis of intelligent field devices via HART protocol.

Source for device description files

See data (→  53)

8.4.6 Field Communicator 475**Function scope**

Industrial handheld terminal from Emerson Process Management for remote configuration and measured value display via HART protocol.

Source for device description files

See data (→  53)

9 System integration

9.1 Overview of device description files

9.1.1 Current version data for the device

Firmware version	01.00.zz	<ul style="list-style-type: none"> ▪ On the title page of the Operating instructions ▪ On transmitter nameplate ▪ Firmware version ▪ "Diagnostics" menu → Device information → Firmware version
Release date of firmware version	12.2013	---
Manufacturer ID	0x11	Manufacturer ID "Expert" menu → Communication → HART output → Information → Manufacturer ID
Device type ID	0x68	Device type "Expert" menu → Communication → HART output → Information → Device type
HART protocol revision	6.0	---
Device revision	1	<ul style="list-style-type: none"> ▪ On transmitter nameplate ▪ Device revision ▪ "Expert" menu → Communication → HART output → Information → Device revision

9.1.2 Operating tools

The suitable device description file for the individual operating tools is listed in the table below, along with information on where the file can be acquired.

Operating tool via HART protocol	Sources for obtaining device descriptions
<ul style="list-style-type: none"> ▪ Field Xpert SFX350 ▪ Field Xpert SFX370 	Use update function of handheld terminal
FieldCare	<ul style="list-style-type: none"> ▪ www.endress.com → Download Area ▪ CD-ROM (contact Endress+Hauser) ▪ DVD (contact Endress+Hauser)
AMS Device Manager (Emerson Process Management)	www.endress.com → Download Area
SIMATIC PDM (Siemens)	www.endress.com → Download Area
Field Communicator 375, 475 (Emerson Process Management)	Use update function of handheld terminal

9.2 Measured variables via HART protocol

The following measured variables (HART device variables) are assigned to the dynamic variables at the factory:

Dynamic variables	Measured variables (HART device variables)
Primary dynamic variable (PV)	Volume flow
Secondary dynamic variable (SV)	Totalizer
Tertiary dynamic variable (TV)	Temperature
Quaternary dynamic variable (QV)	Totalizer

The assignment of the measured variables to the dynamic variables can be modified and assigned as desired via local operation and the operating tool using the following parameters:

- "Expert" menu → Communication → HART output → Output → Assign PV
- "Expert" menu → Communication → HART output → Output → Assign SV
- "Expert" menu → Communication → HART output → Output → Assign TV
- "Expert" menu → Communication → HART output → Output → Assign QV

The following measured variables can be assigned to the dynamic variables:

Measured variables for PV (primary dynamic variable)

- Mass flow
- Volume flow
- Temperature

Measured variables for SV, TV, QV (secondary, tertiary and quaternary dynamic variable)

- Mass flow
- Volume flow
- Temperature
- Totalizer

9.3 Other settings

In the **Configuration** submenu you can configure other settings for the HART protocol (e.g. Burst mode).



An external pressure or temperature sensor must be in the Burst mode.

Navigation

"Expert" menu → Communication → HART output → Configuration

Parameter overview with brief description

Parameter	Description	Selection	Factory setting
Burst mode	Switch burst mode on/off.	<ul style="list-style-type: none"> ▪ Off ▪ On 	Off

10 Commissioning

10.1 Function check

Before commissioning the device, make sure that the post-installation and post-connection checks have been performed.

- "Post-installation check" checklist (→ 📄 27)
- "Post-connection check" checklist

10.2 Switching on the measuring device

After a successful function check, switch on the measuring device.

After a successful startup, the local display switches automatically from the startup display to the measured value display.

i If nothing appears on the local display or a diagnostic message is displayed, refer to the section on "Diagnostics and troubleshooting" (→ 📄 89).

10.3 Setting the operating language

Factory setting: English or ordered local language

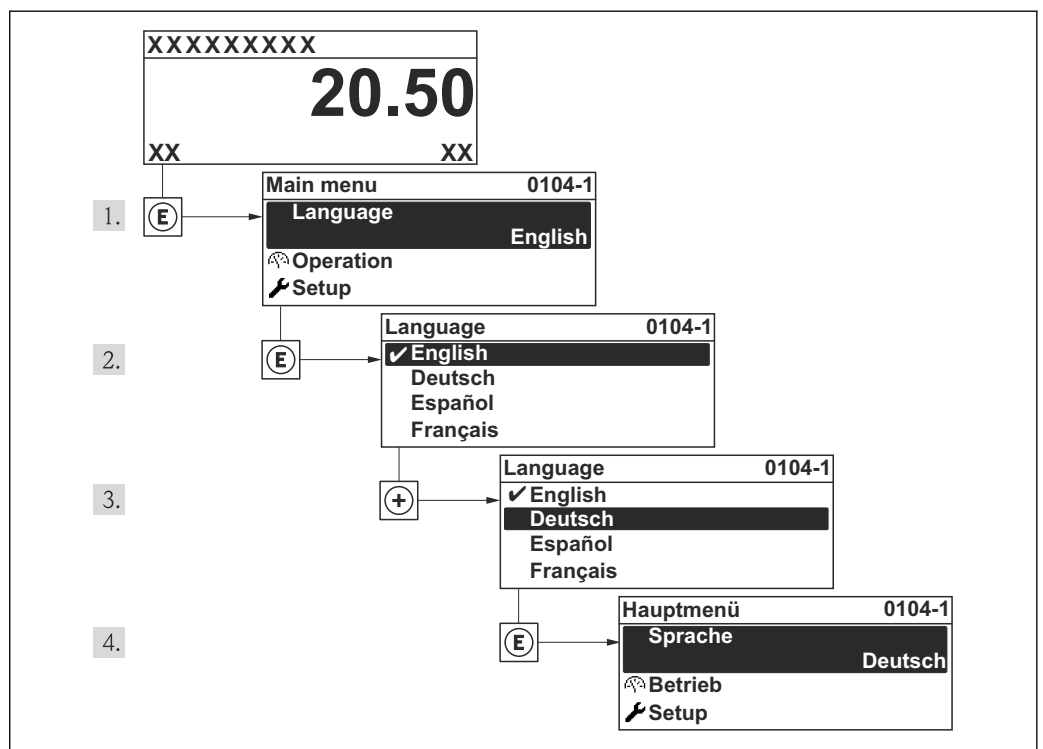

A0013996

10.4 Configuring the measuring device

The **Setup** menu contains all the parameters needed for standard operation.

Navigation to the "Setup" menu

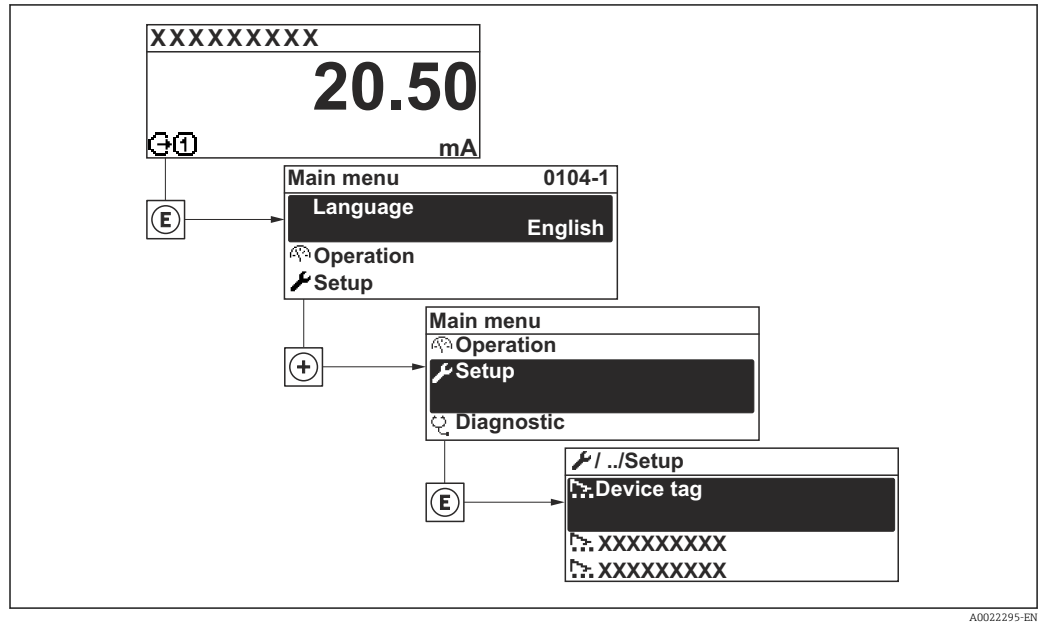

A0022295-EN

Navigation

"Setup" menu

Overview "Setup" menu



Switch-off value
Switch-on value
Assign status
Assign diagnostic behavior
Assign pulse output
Value per pulse
Advanced setup

Parameter overview with brief description



Parameter	Description	User entry / User interface / Selection	Factory setting
Device tag	Enter tag for measuring point.	Max. 32 characters, such as letters, numbers or special characters (e.g. @, %, /).	t-mass
Temperature	Shows currently measured temperature.	Signed floating-point number	1 °C
Pipe inner diameter	Enter the internal diameter of a circular pipe.	min. 32 mm	150 mm
Installation factor	Enter factor to adjust for installation conditions.	0 to 9999	1
Assign status input	Select the function for the status input.	<ul style="list-style-type: none"> ▪ Off ▪ Reset totalizer 1 ▪ Flow override ▪ CIP/SIP mode 	Off
Assign current output	Select process variable for current output.	<ul style="list-style-type: none"> ▪ Volume flow ▪ Mass flow ▪ Temperature 	Volume flow
4 mA value	Enter 4 mA value.	Signed floating-point number	0 l/h
20 mA value	Enter 20 mA value.	Signed floating-point number	317 000 l/h
Operating mode	Define the output as a pulse, frequency or switch output.	<ul style="list-style-type: none"> ▪ Pulse ▪ Frequency ▪ Switch 	Pulse
Assign frequency output	Select process variable for frequency output.	<ul style="list-style-type: none"> ▪ Off ▪ Volume flow ▪ Mass flow ▪ Temperature 	Off
Measuring value at minimum frequency	Enter measured value for minimum frequency.	Signed floating-point number	0
Measuring value at maximum frequency	Enter measured value for maximum frequency.	Signed floating-point number	0
Switch output function	Select function for switch output.	<ul style="list-style-type: none"> ▪ Off ▪ On ▪ Diagnostic behavior ▪ Limit ▪ Status 	Off
Assign limit	Select process variable for limit function.	<ul style="list-style-type: none"> ▪ Volume flow ▪ Mass flow ▪ Temperature ▪ Totalizer 1 	Volume flow
Switch-off value	Enter measured value for the switch-off point.	Signed floating-point number	0 l/h

Parameter	Description	User entry / User interface / Selection	Factory setting
Switch-on value	Enter measured value for the switch-on point.	Signed floating-point number	0 l/h
Assign status	Select device status for switch output.	<ul style="list-style-type: none"> ▪ Partially filled pipe detection ▪ Low flow cut off 	Low flow cut off
Assign diagnostic behavior	Select diagnostic behavior for switch output.	<ul style="list-style-type: none"> ▪ Alarm ▪ Alarm or warning ▪ Warning 	Alarm
Assign pulse output	Select process variable for pulse output.	<ul style="list-style-type: none"> ▪ Off ▪ Volume flow ▪ Mass flow 	Off
Value per pulse	Enter measured value at which a pulse is output.	Signed floating-point number	0

10.4.1 Defining the tag name

To enable fast identification of the measuring point within the system, you can enter a unique designation using the **Device tag** parameter and thus change the factory setting.

 The number of characters displayed depends on the characters used.

 For information on the tag name in the "FieldCare" operating tool (→  50)

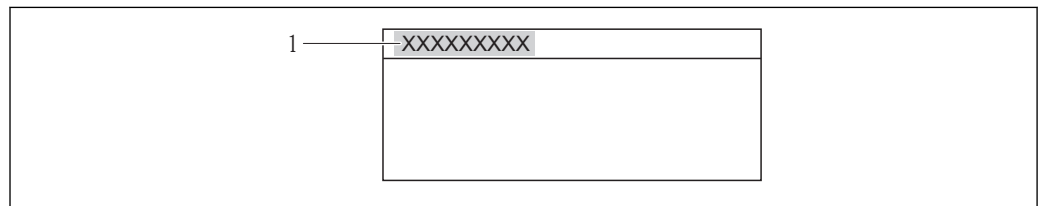

A0013375

 11 Header of the operational display with tag name

1 Device tag

Navigation

"Setup" menu → Device tag

Parameter overview with brief description

Parameter	Description	User entry	Factory setting
Device tag	Enter tag for measuring point.	Max. 32 characters, such as letters, numbers or special characters (e.g. @, %, /).	t-mass

10.5 Advanced settings

The **Advanced setup** submenu with its submenus contains parameters for specific settings.

Navigation to the "Advanced setup" submenu

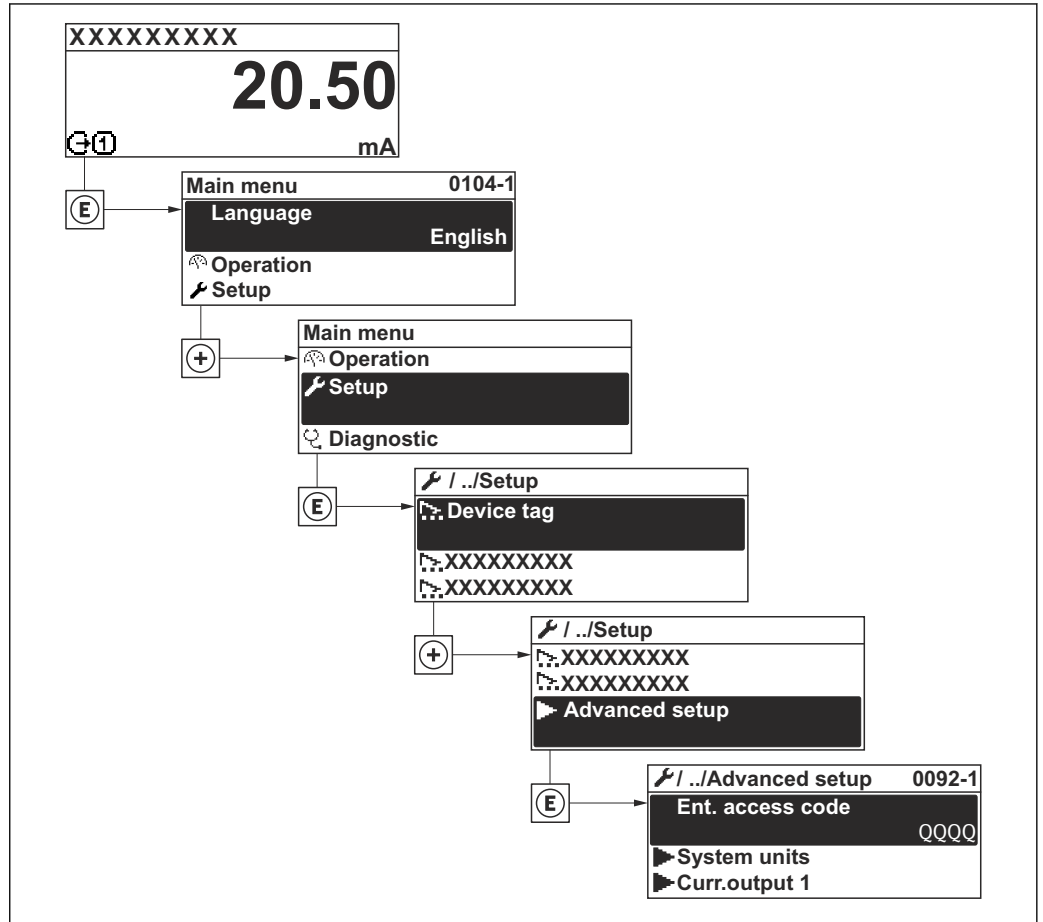

A0022313-EN

Navigation

"Setup" menu → Advanced setup

Overview of the parameters and submenus in the "Advanced setup" submenu

Advanced setup	→	Enter access code	(→ 47)
		System units	(→ 60)
		Current output 1	(→ 61)
		Pulse/frequency/switch output	(→ 63)
		Status input	(→ 69)
		Output conditioning	(→ 70)
		Low flow cut off	(→ 70)
		Totalizer 1	(→ 71)

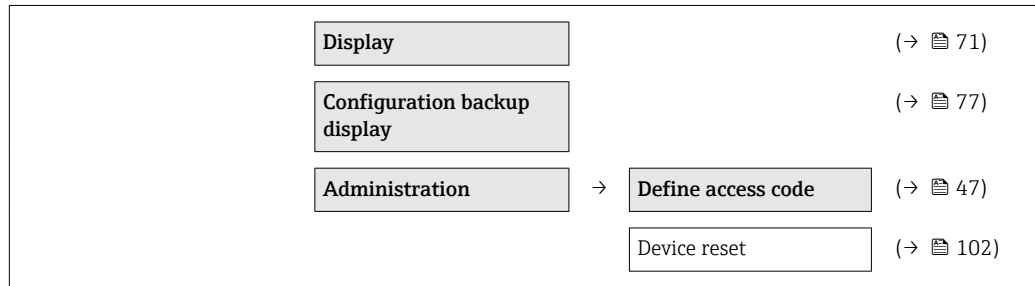

10.5.1 Setting the system units

In the **System units** submenu the units of all the measured values can be set.

Navigation

"Setup" menu → Advanced setup → System units

Structure of the submenu

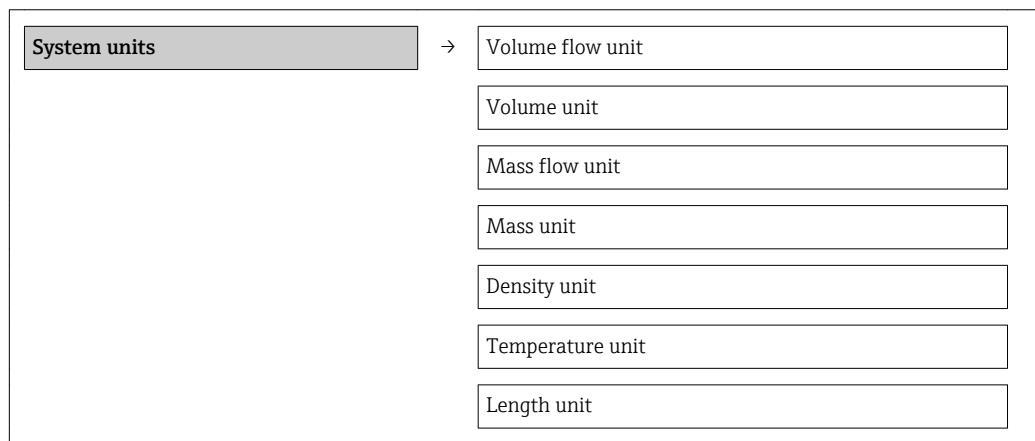

Parameter overview with brief description

Parameter	Description	Selection	Factory setting
Volume flow unit	Select volume flow unit. <i>Result</i> The selected unit applies for: <ul style="list-style-type: none"> ▪ Output ▪ Low flow cut off ▪ Simulation process variable 	Unit choose list	Country-specific: <ul style="list-style-type: none"> ▪ l/h ▪ gal/min (us)
Volume unit	Select volume unit. Result The selected unit is taken from: Volume flow unit parameter	Unit choose list	Country-specific: <ul style="list-style-type: none"> ▪ l ▪ gal (us)
Mass flow unit	Select mass flow unit. <i>Result</i> The selected unit applies for: <ul style="list-style-type: none"> ▪ Output ▪ Low flow cut off ▪ Simulation process variable 	Unit choose list	Country-specific: <ul style="list-style-type: none"> ▪ kg/h ▪ lb/min
Mass unit	Select mass unit. <i>Result</i> The selected unit is taken from: Mass flow unit parameter	Unit choose list	Country-specific: <ul style="list-style-type: none"> ▪ kg ▪ lb

Parameter	Description	Selection	Factory setting
Density unit	Select density unit. <i>Result</i> The selected unit applies for: <ul style="list-style-type: none"> ▪ Output ▪ Simulation process variable ▪ Density adjustment (in Expert menu) 	Unit choose list	Country-specific: <ul style="list-style-type: none"> ▪ kg/l ▪ lb/ft³
Temperature unit	Select temperature unit. <i>Result</i> The selected unit applies for: <ul style="list-style-type: none"> ▪ Output ▪ Reference temperature ▪ Simulation process variable 	Unit choose list	Country-specific: <ul style="list-style-type: none"> ▪ °C (Celsius) ▪ °F (Fahrenheit)
Length unit	Select length unit for nominal diameter.	Unit choose list	Country-specific: <ul style="list-style-type: none"> ▪ mm ▪ in

10.5.2 Configuring the current output

The "**Current output 1**" wizard guides you systematically through all the parameters that have to be set for configuring the current output.

Navigation

"Setup" menu → Advanced setup → Current output 1

Structure of the wizard

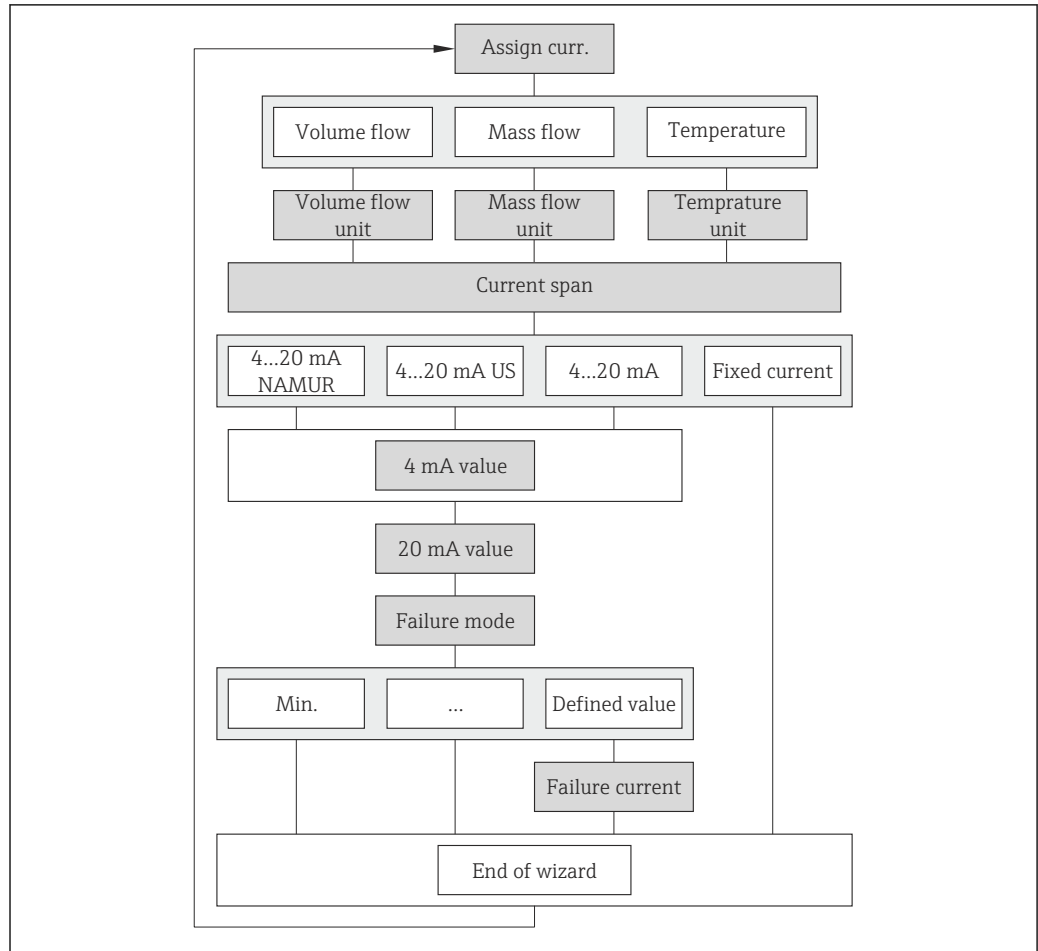

A0022294-EN

12 "Current output 1" wizard in the "Advanced setup" submenu

Parameter overview with brief description

Parameter	Description	Selection / User entry	Factory setting
Assign current output	Select process variable for current output.	<ul style="list-style-type: none"> ■ Volume flow ■ Mass flow ■ Temperature 	Volume flow
Mass flow unit	Select mass flow unit. <i>Result</i> The selected unit applies for: <ul style="list-style-type: none"> ■ Output ■ Low flow cut off ■ Simulation process variable 	Unit choose list	Country-specific: <ul style="list-style-type: none"> ■ kg/h ■ lb/min
Volume flow unit	Select volume flow unit. <i>Result</i> The selected unit applies for: <ul style="list-style-type: none"> ■ Output ■ Low flow cut off ■ Simulation process variable 	Unit choose list	Country-specific: <ul style="list-style-type: none"> ■ l/h ■ gal/min (us)

Parameter	Description	Selection / User entry	Factory setting
Temperature unit	Select temperature unit. <i>Result</i> The selected unit applies for: <ul style="list-style-type: none"> ▪ Output ▪ Reference temperature ▪ Simulation process variable 	Unit choose list	Country-specific: <ul style="list-style-type: none"> ▪ °C (Celsius) ▪ °F (Fahrenheit)
Current span	Select current range for process value output and upper/lower level for alarm signal.	<ul style="list-style-type: none"> ▪ 4...20 mA NAMUR ▪ 4...20 mA US ▪ 4...20 mA ▪ Fixed current 	4...20 mA NAMUR
4 mA value	Enter 4 mA value.	Signed floating-point number	0 l/h
20 mA value	Enter 20 mA value.	Signed floating-point number	0.0025 l/h
Failure mode	Define output behavior in alarm condition.	<ul style="list-style-type: none"> ▪ Min. ▪ Max. ▪ Last valid value ▪ Actual value ▪ Defined value 	Max.
Failure current	Enter current output value in alarm condition.	3.59 to 22.5 mA	22.5 mA

10.5.3 Configuring the pulse/frequency/switch output

The **Pulse/frequency/switch output** wizard guides you systematically through all the parameters that can be set for configuring the selected output type.

Pulse output

Navigation

"Setup" menu → Advanced setup → Pulse/frequency/switch output

Structure of the wizard for the pulse output

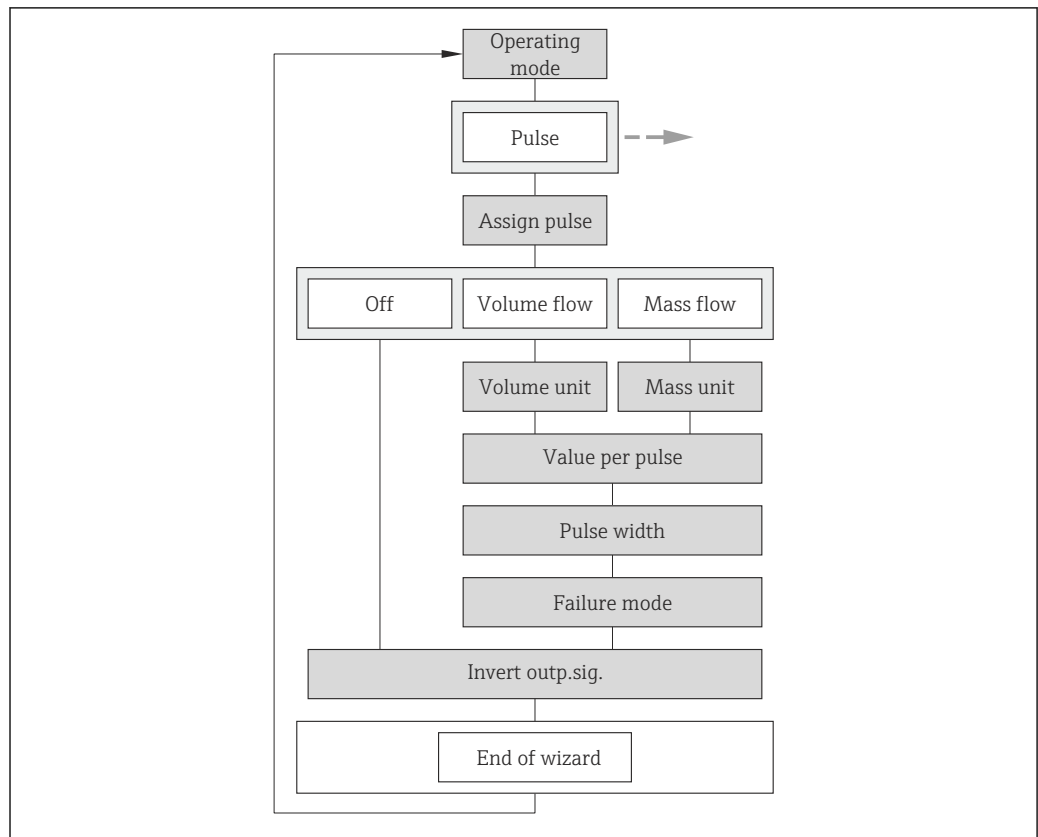

A0022251-EN

13 "Pulse/frequency/switch output" wizard in the "Advanced setup" submenu: "Operating mode" parameter, "Pulse" option

Parameter overview with brief description

Parameter	Description	Selection / User entry	Factory setting
Operating mode	Define the output as a pulse, frequency or switch output.	<ul style="list-style-type: none"> ■ Pulse ■ Frequency ■ Switch 	Pulse
Assign pulse output	Select process variable for pulse output.	<ul style="list-style-type: none"> ■ Off ■ Volume flow ■ Mass flow 	Off
Mass unit	Select mass unit. <i>Result</i> The selected unit is taken from: Mass flow unit parameter	Unit choose list	Country-specific: <ul style="list-style-type: none"> ■ kg ■ lb
Volume unit	Select volume unit. Result The selected unit is taken from: Volume flow unit parameter	Unit choose list	Country-specific: <ul style="list-style-type: none"> ■ l ■ gal (us)
Value per pulse	Enter measured value at which a pulse is output.	Signed floating-point number	0
Pulse width	Define time width of the output pulse.	0.5 to 2 000 ms	100 ms
Failure mode	Define output behavior in alarm condition.	<ul style="list-style-type: none"> ■ Actual value ■ No pulses 	No pulses
Invert output signal	Invert the output signal.	<ul style="list-style-type: none"> ■ No ■ Yes 	No

Frequency output

Navigation

"Setup" menu → Advanced setup → Pulse/frequency/switch output

Structure of the wizard for the frequency output

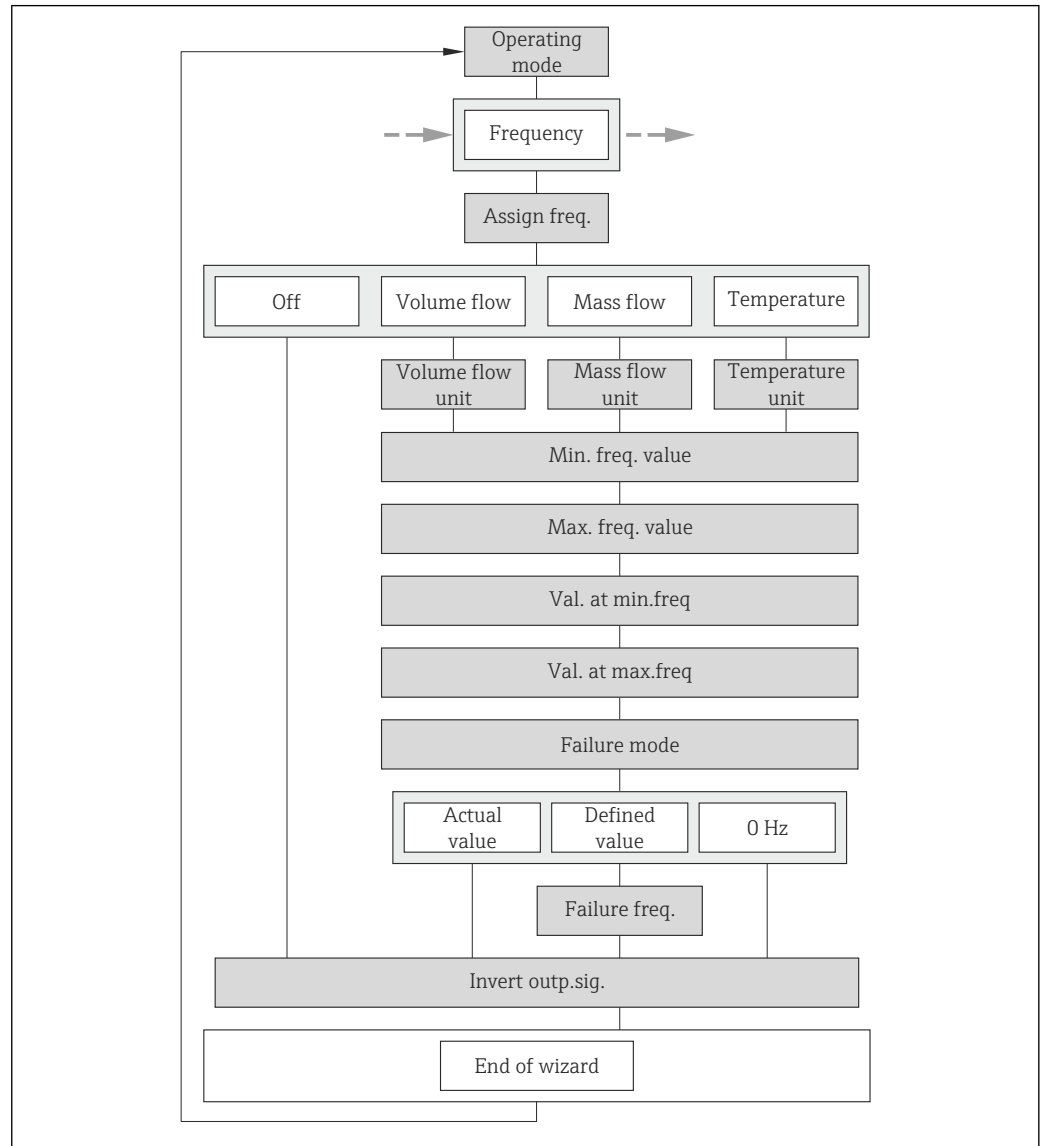

A0022253-EN

14 "Pulse/frequency/switch output" wizard in the "Advanced setup" submenu: "Operating mode" parameter, "Frequency" option

Parameter overview with brief description

Parameter	Description	Selection / User entry	Factory setting
Operating mode	Define the output as a pulse, frequency or switch output.	<ul style="list-style-type: none"> ■ Pulse ■ Frequency ■ Switch 	Pulse
Assign frequency output	Select process variable for frequency output.	<ul style="list-style-type: none"> ■ Off ■ Volume flow ■ Mass flow ■ Temperature 	Off

Parameter	Description	Selection / User entry	Factory setting
Mass flow unit	Select mass flow unit. <i>Result</i> The selected unit applies for: <ul style="list-style-type: none"> ▪ Output ▪ Low flow cut off ▪ Simulation process variable 	Unit choose list	Country-specific: <ul style="list-style-type: none"> ▪ kg/h ▪ lb/min
Volume flow unit	Select volume flow unit. <i>Result</i> The selected unit applies for: <ul style="list-style-type: none"> ▪ Output ▪ Low flow cut off ▪ Simulation process variable 	Unit choose list	Country-specific: <ul style="list-style-type: none"> ▪ l/h ▪ gal/min (us)
Temperature unit	Select temperature unit. <i>Result</i> The selected unit applies for: <ul style="list-style-type: none"> ▪ Output ▪ Reference temperature ▪ Simulation process variable 	Unit choose list	Country-specific: <ul style="list-style-type: none"> ▪ °C (Celsius) ▪ °F (Fahrenheit)
Minimum frequency value	Enter minimum frequency.	0.0 to 1 000.0 Hz	0.0 Hz
Maximum frequency value	Enter maximum frequency.	0.0 to 1 000.0 Hz	1 000.0 Hz
Measuring value at minimum frequency	Enter measured value for minimum frequency.	Signed floating-point number	0
Measuring value at maximum frequency	Enter measured value for maximum frequency.	Signed floating-point number	0
Failure mode	Define output behavior in alarm condition.	<ul style="list-style-type: none"> ▪ Actual value ▪ Defined value ▪ 0 Hz 	0 Hz
Failure frequency	Enter frequency output value in alarm condition.	0.0 to 1 250.0 Hz	0.0 Hz
Invert output signal	Invert the output signal.	<ul style="list-style-type: none"> ▪ No ▪ Yes 	No

Switch output

Navigation

"Setup" menu → Advanced setup → Pulse/frequency/switch output

Structure of the wizard for the switch output

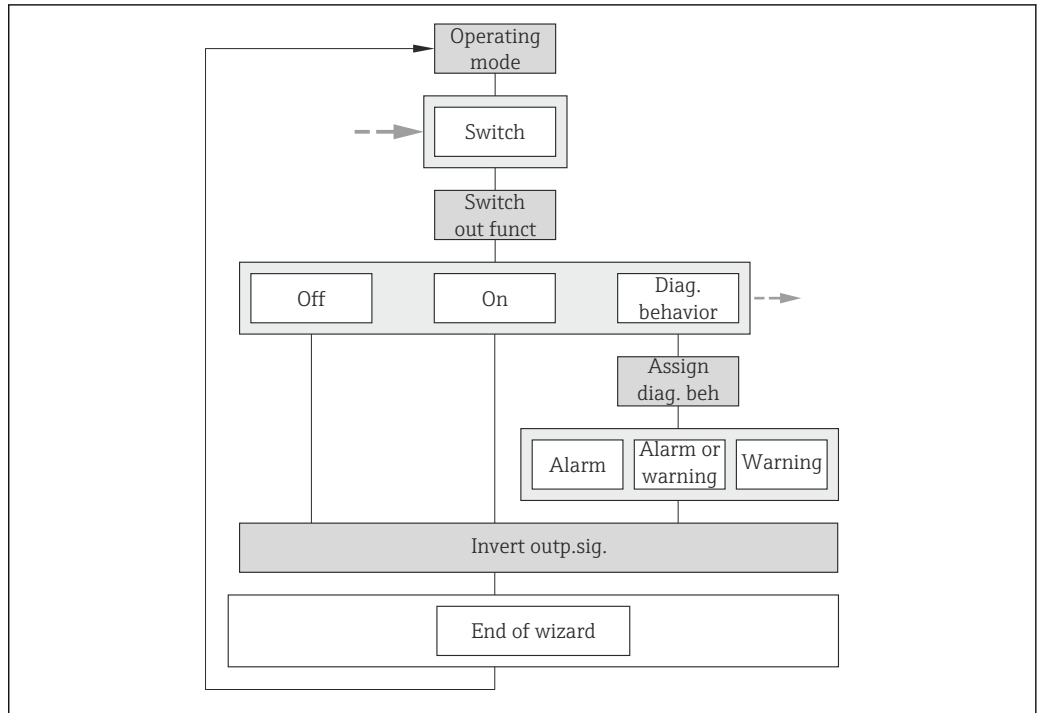

A0018575-EN

15 "Pulse/frequency/switch output" wizard in the "Advanced setup" submenu: "Operating mode" parameter, "Switch" option (part 1)

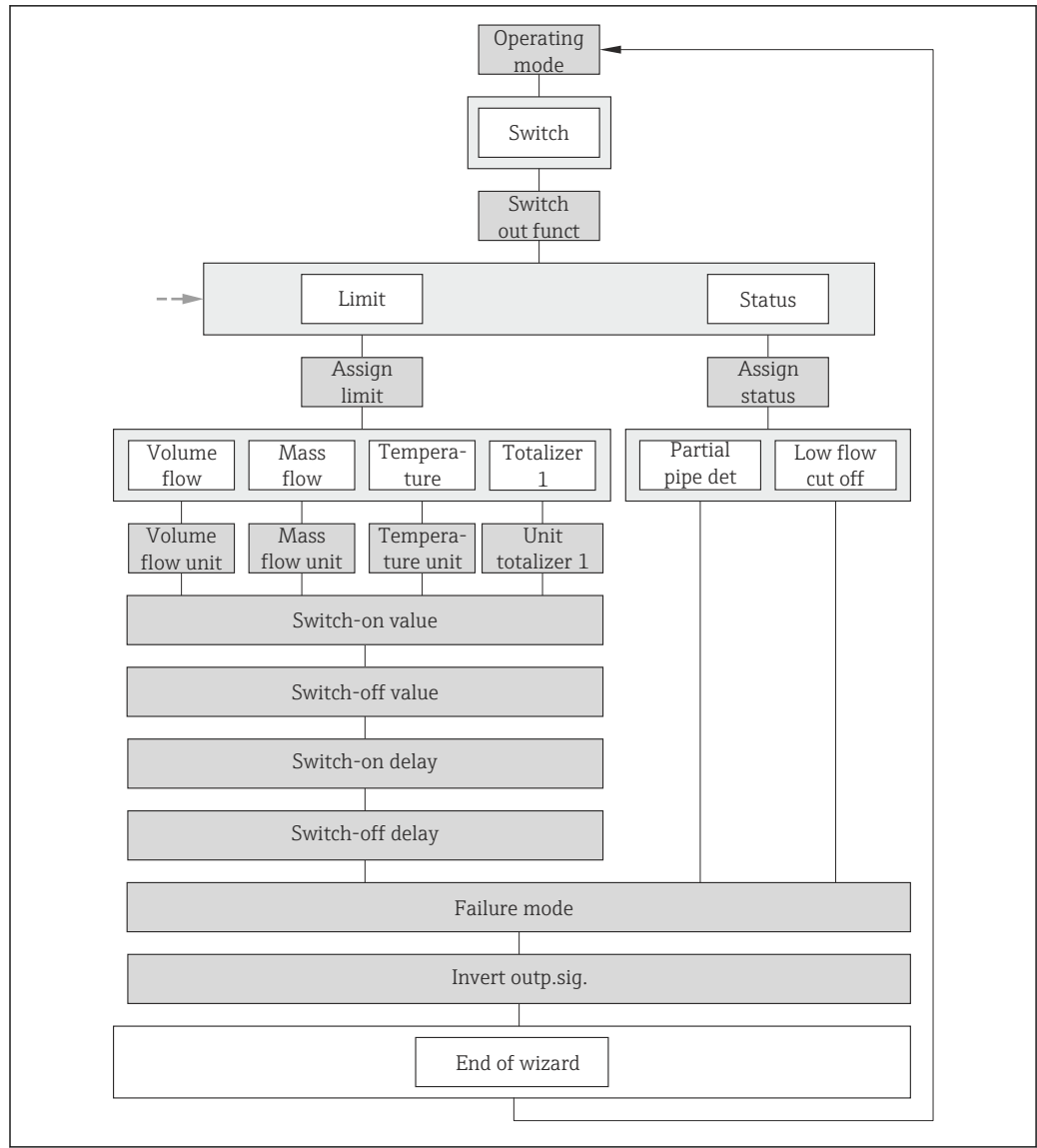

A0022254-EN

16 "Pulse/frequency/switch output" wizard in the "Advanced setup" submenu: "Operating mode" parameter, "Switch" option (part 2)



Parameter overview with brief description

Parameter	Description	Selection / User entry	Factory setting
Operating mode	Define the output as a pulse, frequency or switch output.	<ul style="list-style-type: none"> ▪ Pulse ▪ Frequency ▪ Switch 	Pulse
Switch output function	Select function for switch output.	<ul style="list-style-type: none"> ▪ Off ▪ On ▪ Diagnostic behavior ▪ Limit ▪ Status 	Off
Assign diagnostic behavior	Select diagnostic behavior for switch output.	<ul style="list-style-type: none"> ▪ Alarm ▪ Alarm or warning ▪ Warning 	Alarm
Assign limit	Select process variable for limit function.	<ul style="list-style-type: none"> ▪ Volume flow ▪ Mass flow ▪ Temperature ▪ Totalizer 1 	Volume flow

Parameter	Description	Selection / User entry	Factory setting
Assign status	Select device status for switch output.	<ul style="list-style-type: none"> ■ Partially filled pipe detection ■ Low flow cut off 	Low flow cut off
Mass flow unit	Select mass flow unit. <i>Result</i> The selected unit applies for: <ul style="list-style-type: none"> ■ Output ■ Low flow cut off ■ Simulation process variable 	Unit choose list	Country-specific: <ul style="list-style-type: none"> ■ kg/h ■ lb/min
Volume flow unit	Select volume flow unit. <i>Result</i> The selected unit applies for: <ul style="list-style-type: none"> ■ Output ■ Low flow cut off ■ Simulation process variable 	Unit choose list	Country-specific: <ul style="list-style-type: none"> ■ l/h ■ gal/min (us)
Temperature unit	Select temperature unit. <i>Result</i> The selected unit applies for: <ul style="list-style-type: none"> ■ Output ■ Reference temperature ■ Simulation process variable 	Unit choose list	Country-specific: <ul style="list-style-type: none"> ■ °C (Celsius) ■ °F (Fahrenheit)
Unit totalizer	Select process variable totalizer unit.	Unit choose list	m ³
Switch-on value	Enter measured value for the switch-on point.	Signed floating-point number	0 l/h
Switch-off value	Enter measured value for the switch-off point.	Signed floating-point number	0 l/h
Switch-on delay	Define delay for the switch-on of status output.	0.0 to 100.0 s	0.0 s
Switch-off delay	Define delay for the switch-off of status output.	0.0 to 100.0 s	0.0 s
Failure mode	Define output behavior in alarm condition.	<ul style="list-style-type: none"> ■ Actual status ■ Open ■ Closed 	Open
Invert output signal	Invert the output signal.	<ul style="list-style-type: none"> ■ No ■ Yes 	No

10.5.4 Configuring the status input

The **Status input** submenu guides you systematically through all the parameters that have to be set for configuring the input.

 The submenu only appears if the device was ordered with a status input (→  29).

Navigation

"Setup" menu → Advanced setup → Status input

Structure of the submenu

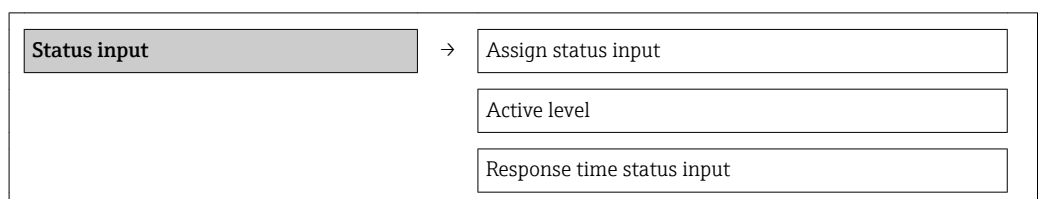

Parameter overview with brief description

Parameter	Description	Selection / User entry	Factory setting
Assign status input	Select the function for the status input.	<ul style="list-style-type: none"> ■ Off ■ Reset totalizer 1 ■ Flow override ■ CIP/SIP mode 	Off
Active level	Specify the input signal level at which the assigned function is triggered.	<ul style="list-style-type: none"> ■ High ■ Low 	High
Response time status input	Specify the minimum amount of time the input signal level must be present before the selected function is triggered.	5 to 200 ms	50 ms

10.5.5 Configuring the output conditioning

The **Output conditioning** submenu contains all the parameters that must be configured for the configuration of output conditioning.

Navigation

"Setup" menu → Advanced setup → Output conditioning

Structure of the submenu

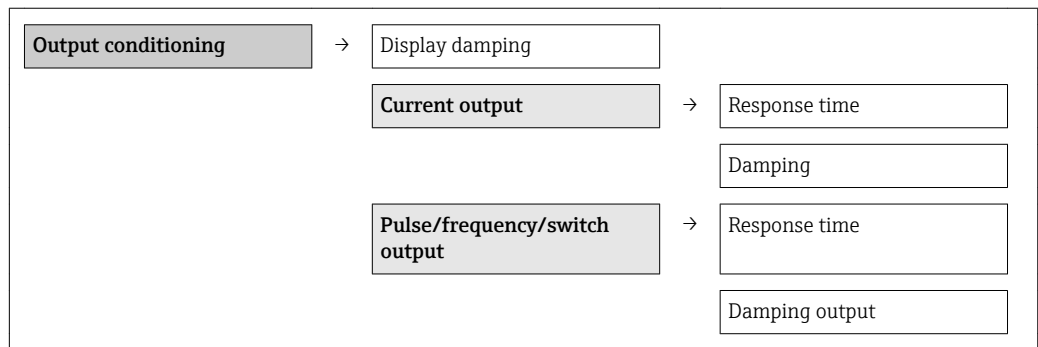

Parameter overview with brief description

Parameter	Description	User entry / User interface	Factory setting
Display damping	Set display reaction time to fluctuations in the measured value.	0.0 to 999.9 s	0.0 s
Response time	Specifies how quickly the output reaches the measured value change of 63 % of 100 % of the measured value change.	Positive floating-point number	0 s
Damping output	Set reaction time for output signal to fluctuations in the measured value.	0.0 to 999.9 s	1.0 s
Response time	Specifies how quickly the output reaches the measured value change of 63 % of 100 % of the measured value change.	Positive floating-point number	0 s
Damping output	Set reaction time for output signal to fluctuations in the measured value.	0 to 999.9 s	0.0 s

10.5.6 Configuring the low flow cut off

The **Low flow cut off** submenu contains parameters that must be configured for the configuration of low flow cut off.

Navigation

"Setup" menu → Advanced setup → Low flow cut off

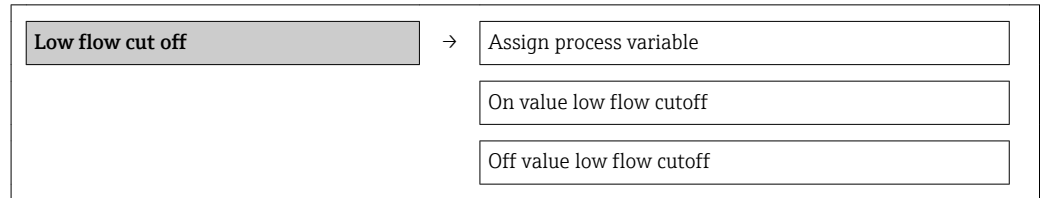
Structure of the submenu**Parameter overview with brief description**

Parameter	Description	Selection / User entry	Factory setting
Assign process variable	Select process variable for low flow cut off.	<ul style="list-style-type: none"> ■ Off ■ Volume flow ■ Mass flow 	Volume flow
On value low flow cutoff	Enter on value for low flow cut off.	Signed floating-point number	0 l/h
Off value low flow cutoff	Enter off value for low flow cut off.	0 to 100.0 %	50 %

10.5.7 Configuring the totalizer

In the "Totalizer 1" submenu the individual totalizers can be configured.

Navigation

"Setup" menu → Advanced setup → Totalizer 1

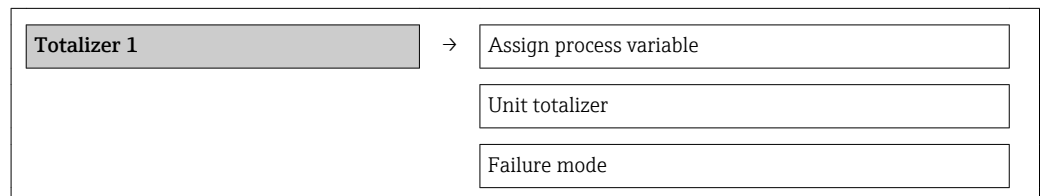
Structure of the submenu**Parameter overview with brief description**

Parameter	Description	Selection	Factory setting
Assign process variable	Select process variable for totalizer.	<ul style="list-style-type: none"> ■ Off ■ Volume flow ■ Mass flow 	Volume flow
Unit totalizer	Select process variable totalizer unit.	Unit choose list	m ³
Failure mode	Define totalizer behavior in alarm condition.	<ul style="list-style-type: none"> ■ Stop ■ Actual value ■ Last valid value 	Stop

10.5.8 Carrying out additional display configurations

In the "Display" submenu you can set all the parameters involved in the configuration of the local display.

Navigation

"Setup" menu → Advanced setup → Display

Structure of the submenu

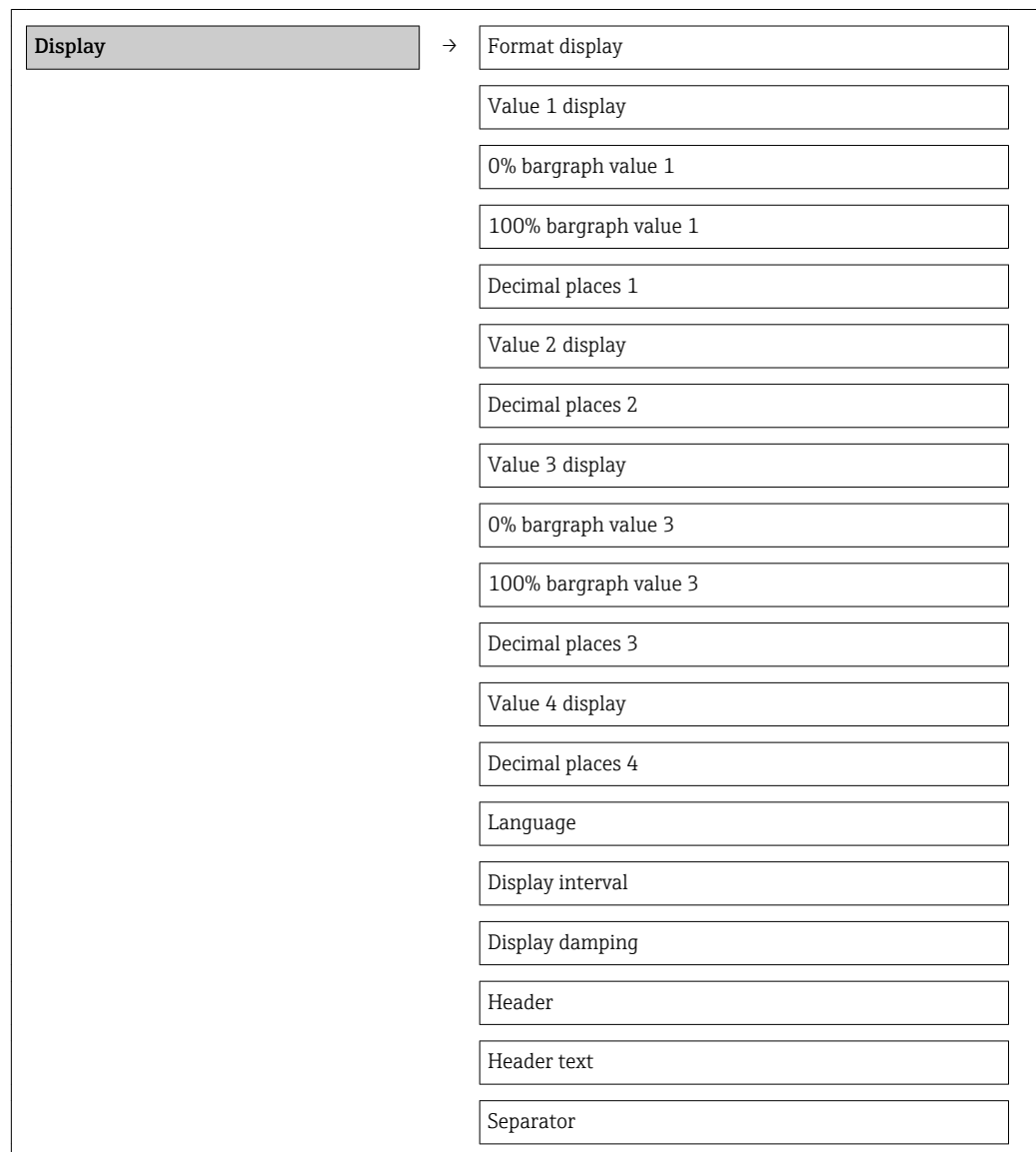

Parameter overview with brief description

Parameter	Description	Selection / User entry	Factory setting
Format display	Select how measured values are shown on the display.	<ul style="list-style-type: none"> ▪ 1 value, max. size ▪ 1 bargraph + 1 value ▪ 2 values ▪ 1 value large + 2 values ▪ 4 values 	1 value, max. size
Value 1 display	Select the measured value that is shown on the local display.	<ul style="list-style-type: none"> ▪ Volume flow ▪ Mass flow ▪ Temperature ▪ Totalizer 1 ▪ Current output 	Volume flow
0% bargraph value 1	Enter 0% value for bar graph display.	Signed floating-point number	0 l/h
100% bargraph value 1	Enter 100% value for bar graph display.	Signed floating-point number	0.001 l/h

Parameter	Description	Selection / User entry	Factory setting
Decimal places 1	Select the number of decimal places for the display value.	<ul style="list-style-type: none"> ■ x ■ x.x ■ x.xx ■ x.xxx ■ x.xxxx 	x.xx
Value 2 display	Select the measured value that is shown on the local display.	Picklist (see 1st display value)	None
Decimal places 2	Select the number of decimal places for the display value.	<ul style="list-style-type: none"> ■ x ■ x.x ■ x.xx ■ x.xxx ■ x.xxxx 	x.xx
Value 3 display	Select the measured value that is shown on the local display.	Picklist (see 1st display value)	None
0% bargraph value 3	Enter 0% value for bar graph display.	Signed floating-point number	0
100% bargraph value 3	Enter 100% value for bar graph display.	Signed floating-point number	0
Decimal places 3	Select the number of decimal places for the display value.	<ul style="list-style-type: none"> ■ x ■ x.x ■ x.xx ■ x.xxx ■ x.xxxx 	x.xx
Value 4 display	Select the measured value that is shown on the local display.	Picklist (see 1st display value)	None
Decimal places 4	Select the number of decimal places for the display value.	<ul style="list-style-type: none"> ■ x ■ x.x ■ x.xx ■ x.xxx ■ x.xxxx 	x.xx
Language	Set display language.	<ul style="list-style-type: none"> ■ English ■ Deutsch ■ Français ■ Español ■ Italiano ■ Nederlands ■ Portuguesa ■ Polski ■ русский язык (Russian) ■ Svenska ■ Türkçe ■ 中文 (Chinese) ■ 日本語 (Japanese) ■ 한국어 (Korean) ■ tiếng Việt (Vietnamese) ■ čeština (Czech) 	English
Display interval	Set time measured values are shown on display if display alternates between values.	1 to 10 s	5 s
Display damping	Set display reaction time to fluctuations in the measured value.	0.0 to 999.9 s	0.0 s
Header	Select header contents on local display.	Enter display header text.	Device tag
Header text	Enter display header text.		-----
Separator	Select decimal separator for displaying numerical values.	<ul style="list-style-type: none"> ■ . ■ , 	.

10.5.9 Partly filled pipe detection

The **Assign behavior of diagnostic no. 862** parameter can be configured in such a way that the device issues an alarm or a warning if the sensor is not wetted.

 Reliable detection can only be guaranteed in applications with water.

Navigation

"Expert" menu → System → Diagnostic handling → Diagnostic behavior → Assign behavior of diagnostic no. 862

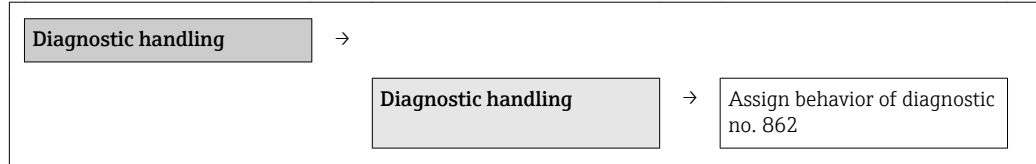

Parameter overview with brief description

Parameter	Description	Selection	Factory setting
Assign behavior of diagnostic no. 862		<ul style="list-style-type: none"> ■ Off ■ Alarm ■ Warning ■ Logbook entry only 	Off

10.5.10 Performing in-situ adjustment

The **In-situ adjustment** submenu is used to adjust the flow output by the device to the real flow of the facility. By taking into consideration the actual process-specific conditions at the facility, including any effects from installation, in-situ adjustment provides flow display that is adapted to the local conditions.

In-situ adjustment is particularly advisable in the following situations:

- In the event of pipe nominal diameters > DN 150 (6")
- For unfavorable inlet and outlet conditions
- If working with liquids other than water

-  ■ Temperature compensation is optimized for applications with water.
- In the case of other fluids, the deviation caused by temperature compensation can be greater.
 - For optimum results, it is advisable to use a reference device with traceable calibration for the adjustment.
 - If a reference device is not available, a pump characteristic curve, for example, can act as the reference instead.

Specification:

- Influence of medium temperature:
 - ±2 % o.r./K in relation to the fluid temperature present during in-situ adjustment
- Linearity:
 - ±5 %o.f.s.
- Fluid:
 - Water
- Measuring range:
 - 0.2 to 5 m/s (0.66 to 16.4 ft/s)
- Number of flow points:
 - Min. 2 and max. 8 flow points
 - For flow velocities < 0.2 m/s (0.66 ft/s), it is recommended to define a zero point in addition to the minimum requirement of two flow points.

In-situ adjustment assigns a maximum of 8 flow points to the individual power coefficients. It is advisable to assign at least 2 flow points. The power coefficients are used to create a calibration curve. The user can choose to save, delete or use the calibration curve that is created.

Navigation

"Expert" menu → Sensor → Sensor adjustment → In-situ adjustment

"In-situ adjustment" submenu

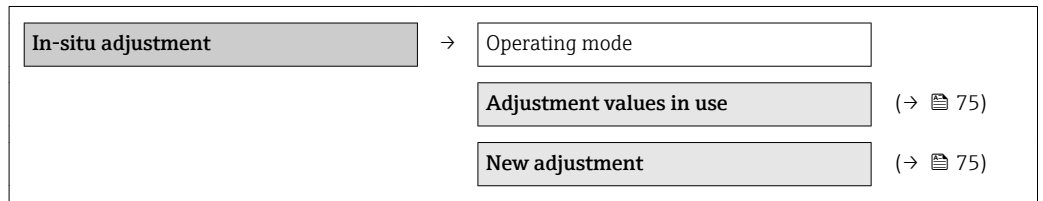

Parameter overview with brief description

Parameter	Description	Selection	Factory setting
Operating mode	Switch the used adjustment on and off.	<ul style="list-style-type: none"> ■ Disabled ■ Enabled 	Disabled

"Adjustment values in use" submenu

The **Adjustment values in use** submenu allows the user to use the assigned adjustment values following successful in-situ adjustment. If the user confirms the use of the values, these values are transferred to the **Adjustment values in use** submenu and the **Operating mode** parameter switches to **Enabled** option. The user can call up the values currently used in this data block and view the flow points and the assigned power coefficients. If a new adjustment has been performed successfully and the use of the new values has been confirmed, the current adjustment values in the **Adjustment values in use** submenu are overwritten.

Navigation

"Expert" menu → Sensor → Sensor adjustment → In-situ adjustment → Adjustment values in use

"Adjustment values in use" submenu

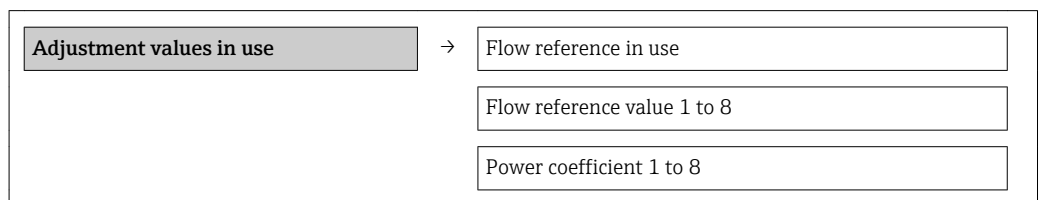

Parameter overview with brief description

Parameter	Description	User interface	Factory setting
Flow reference in use	Shows which process variable has been defined as reference for adjustment.	<ul style="list-style-type: none"> ■ Volume flow ■ Mass flow 	Volume flow
Flow reference value 1 to 8	Shows which flow rate has been defined as reference value for the adjustment.	Signed floating-point number	0 l/h
Power coefficient 1 to 8	Shows which power coefficient has been assigned for the adjustment.	Positive floating-point number	0 mW/K

"New adjustment" submenu

The **New adjustment** submenu contains the **Perform adjustment** submenu (→ 76) and the **Use adjustment** submenu (→ 77) and enables the user to perform in-situ adjustment - either with a new adjustment or an adjustment already performed.

Navigation

"Expert" menu → Sensor → Sensor adjustment → In-situ adjustment → New adjustment

"New adjustment" submenu

New adjustment	→	Select flow reference	
		Perform adjustment	(→ ⓘ 76)
		Use adjustment	(→ ⓘ 77)

Parameter overview with brief description

Parameter	Description	Selection	Factory setting
Select flow reference	Define which process variable is to be used as reference for adjustment.	<ul style="list-style-type: none"> ■ Volume flow ■ Mass flow 	Volume flow

"Perform adjustment" submenu

The **Perform adjustment** submenu contains all the parameters that the user needs to perform in-situ adjustment.

A minimum of one operating flow point in the plant's facility must be set in order for the electronics to be able to generate an adjustment curve. A total of up to 8 flow points can be entered. The user must first select the flow reference (i.e. mass flow or volume flow) before the adjustment can be started. The user selects the desired flow point, waits until the flow is stable and enters the flow rate (usually using a comparison measurement) for the **Flow reference value** parameter. The corresponding power coefficient is assigned automatically. Additional flow points can be entered via the parameters **Flow reference values 2-8**.

Navigation

"Expert" menu → Sensor → Sensor adjustment → In-situ adjustment → New adjustment → Perform adjustment

"Perform adjustment" submenu

Perform adjustment	→	Clear values
		Flow reference value 1 to 8
		Power coefficient 1 to 8

Parameter overview with brief description

Parameter	Description	Selection / User entry / User interface	Factory setting
Clear values	Delete or keep the existing adjustment values.	<ul style="list-style-type: none"> ■ Cancel ■ Clear values 	Cancel
Flow reference value 1	Enter the flow rate as reference for the flow point.	Signed floating-point number	0 l/h
Power coefficient 1	Shows the automatically assigned power coefficient which is directly proportional to the flow: heater power/measured temperature difference.	Positive floating-point number	0 mW/K

"Use adjustment" submenu

The **Use adjustment** submenu contains all the parameters that the user needs to check the validity of the adjustment previously performed.

Navigation

"Expert" menu → Sensor → Sensor adjustment → In-situ adjustment → New adjustment → Use adjustment

"Use adjustment" submenu

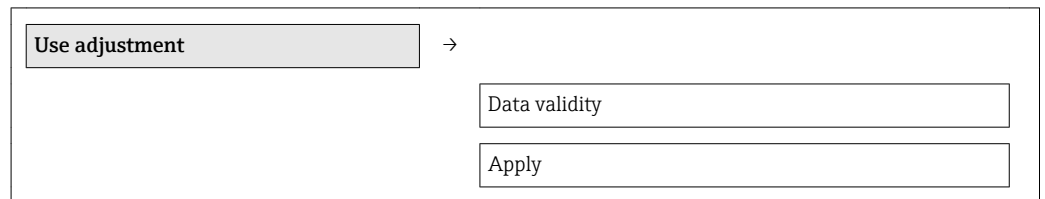

Parameter overview with brief description

Parameter	Prerequisite	Description	User interface / Selection	Factory setting
Data validity	-	Shows whether the performed adjustment is useable.	<ul style="list-style-type: none"> ■ Ok ■ Too few points ■ Invalid pair of values ■ Values too close ■ Out of range 	Ok
Apply	In the Data validity parameter the Ok option is displayed.	Decide whether the adjustment values are to be used.	<ul style="list-style-type: none"> ■ Cancel ■ Ok 	Cancel

10.6 Configuration management

After commissioning, you can save the current device configuration, copy it to another measuring point or restore the previous device configuration.

You can do so using the **Configuration management** parameter and the related options found in the submenu **Configuration backup display** submenu .

Navigation

"Setup" menu → Advanced setup → Configuration backup display

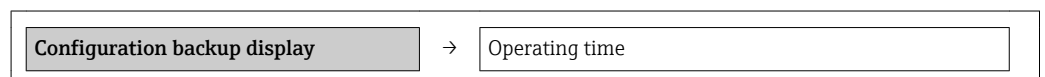

	Last backup
	Configuration management
	Comparison result

Parameter overview with brief description

Parameter	Description	User interface / Selection	Factory setting
Operating time	Indicates how long the device has been in operation.	Days (d), hours (h), minutes (m), seconds (s)	–
Last backup	Indicates when the last data backup was saved to the display module.	Days (d), hours (h), minutes (m), seconds (s)	–
Configuration management	Select action for managing the device data in the display module.	<ul style="list-style-type: none"> ▪ Cancel ▪ Execute backup ▪ Restore ▪ Duplicate ▪ Compare ▪ Clear backup data 	Cancel
Comparison result	Comparison between present device data and display backup.	<ul style="list-style-type: none"> ▪ Settings identical ▪ Settings not identical ▪ No backup available ▪ Backup settings corrupt ▪ Check not done ▪ Dataset incompatible 	Check not done

10.6.1 Function scope of "Configuration management" parameter"

Options	Description
Cancel	No action is executed and the user exits the parameter.
Execute backup	The current device configuration is backed up from the integrated HistoROM to the device's display module. The backup copy includes the transmitter data of the device.
Restore	The last backup copy of the device configuration is restored from the display module to the device's integrated HistoROM. The backup copy includes the transmitter data of the device.
Duplicate	The transmitter configuration from another device is duplicated to the device using the display module.
Compare	The device configuration saved in the display module is compared with the current device configuration of the integrated HistoROM.
Clear backup data	The backup copy of the device configuration is deleted from the display module of the device.

 While this action is in progress, the configuration cannot be edited via the local display and a message on the processing status appears on the display.

10.7 Simulation

The **Simulation** submenu enables you to simulate, without a real flow situation, various process variables in the process and the device alarm mode and to verify downstream signal chains (switching valves or closed-control loops).

Navigation
 "Diagnostics" menu → Simulation

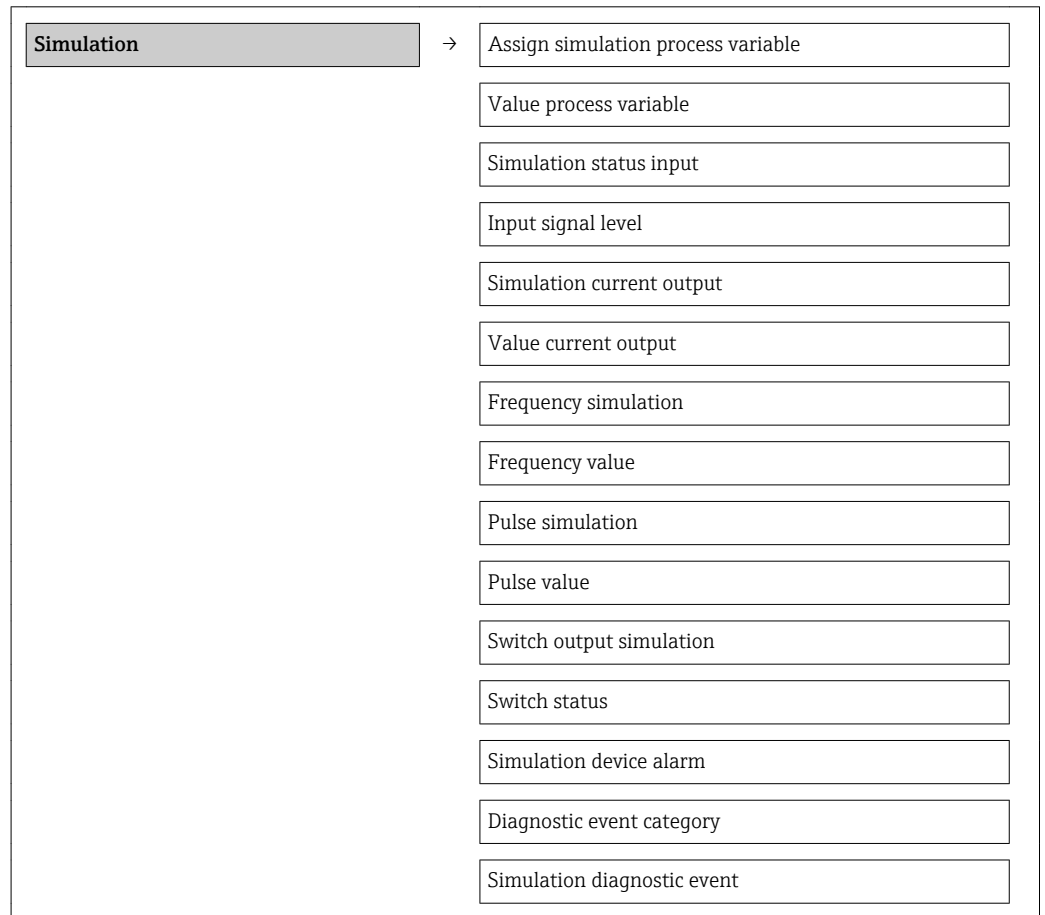

Parameter overview with brief description

Parameter	Prerequisite	Description	Selection / User entry	Factory setting
Assign simulation process variable	–	Select a process variable for the simulation process that is activated.	<ul style="list-style-type: none"> ▪ Off ▪ Volume flow ▪ Mass flow ▪ Temperature 	Off
Value process variable	A process variable is selected in the Assign simulation process variable parameter.	Enter the simulation value for the selected process variable.	Signed floating-point number	0
Simulation status input	–	Switch simulation of the status input on and off.	<ul style="list-style-type: none"> ▪ Off ▪ On 	Off
Input signal level	–	Select the signal level for the simulation of the status input.	<ul style="list-style-type: none"> ▪ High ▪ Low 	High
Simulation current output	–	Switch simulation of the current output on and off.	<ul style="list-style-type: none"> ▪ Off ▪ On 	Off
Value current output	The On option is selected in the Current output simulation parameter.	Enter the current value for simulation.	3.59 to 22.5 mA	3.59 mA
Frequency simulation	–	Switch simulation of the frequency output on and off.	<ul style="list-style-type: none"> ▪ Off ▪ On 	Off
Frequency value	The On option is selected in the Frequency output simulation parameter.	Enter the frequency value for simulation.	0.0 to 1 250.0 Hz	0.0 Hz

Parameter	Prerequisite	Description	Selection / User entry	Factory setting
Pulse simulation	The Down-count. val. option is selected in the Simulation pulse output parameter.	Switch simulation of the pulse output on and off.  If the Fixed value option is selected, the Pulse width parameter defines the pulse width of the pulses output.	<ul style="list-style-type: none"> ▪ Off ▪ Fixed value ▪ Down-counting value 	Off
Pulse value	The Down-count. val. option is selected in the Simulation pulse output parameter.	Enter the number of pulses for simulation.	0 to 65 535	0
Switch output simulation	–	Switch simulation of switch output on and off.	<ul style="list-style-type: none"> ▪ Off ▪ On 	Off
Switch status	The On option is selected in the Switch output simulation parameter.	Select the status of the status output for the simulation.	<ul style="list-style-type: none"> ▪ Open ▪ Closed 	Open
Simulation device alarm	–	Switch the device alarm on and off.	<ul style="list-style-type: none"> ▪ Off ▪ On 	Off
Diagnostic event category	–	Select the category of the diagnostic event.	<ul style="list-style-type: none"> ▪ Sensor ▪ Electronics ▪ Configuration ▪ Process 	Sensor
Simulation diagnostic event	–	Enter the diagnostic number for the diagnostic event.	Positive integer	65 533

10.8 Protecting settings from unauthorized access

The following options exist for protecting the configuration of the measuring device from unintentional modification after commissioning:

- Write protection via access code
- Write protection via write protection switch
- Write protection via keypad lock

10.8.1 Write protection via access code

With the customer-specific access code, the parameters for the measuring device configuration are write-protected and their values can no longer be changed via local operation.

Navigation

"Setup" menu → Advanced setup → Administration → Define access code

Structure of the submenu

Define access code	→	<input style="width: 95%; height: 20px;" type="text" value="Define access code"/>
		<input style="width: 95%; height: 20px;" type="text" value="Confirm access code"/>

Defining the access code via local display

Define access code

1. Navigate to the **Enter access code** parameter.
2. Define a max. 4-digit numeric code as an access code.
3. Enter the access code again to confirm the code.
 - ↳ The -symbol appears in front of all write-protected parameters.

The device automatically locks the write-protected parameters again if a key is not pressed for 10 minutes in the navigation and editing view. The device locks the write-protected parameters automatically after 60 s if the user skips back to the operational display mode from the navigation and editing view.

- i
 - If write access is activated via access code, it can be also be deactivated only via the access code (→ 47).
 - The user role with which the user is currently logged on via the local display (→ 47) is indicated by the **Access status display** parameter. "Operation" menu → Access status display

Parameters which can always be modified via the local display

Certain parameters that do not affect the measurement are excepted from write protection via the local display. Despite the defined access code, these parameters can always be modified even if the other parameters are locked.

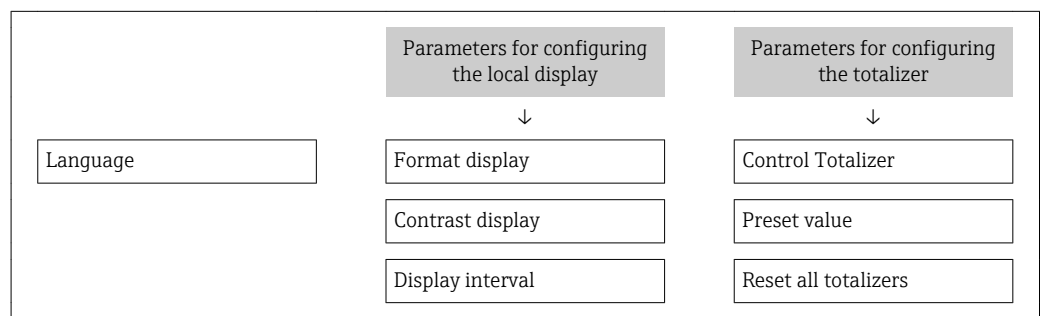

10.8.2 Write protection via write protection switch

Unlike write protection via user-specific access code, this allows write access to the entire operating menu - other than the **Contrast display** parameter - to be locked.

The parameter values are now read only and cannot be edited any more (exception **Contrast display** parameter):

- Via local display
- Via service interface (CDI)
- Via HART protocol

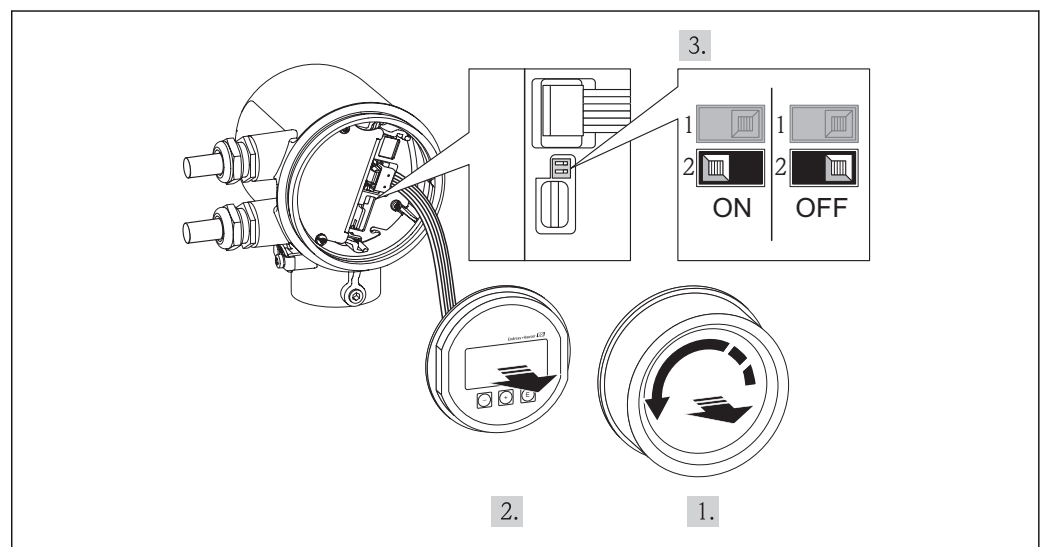

1. Unscrew the electronics compartment cover.

A0017255

2. Pull out the display module with a gentle rotational movement. To make it easier to access the lock switch, attach the display module to the edge of the electronics compartment.
 - ↳ Display module is attached to the edge of the electronics compartment.

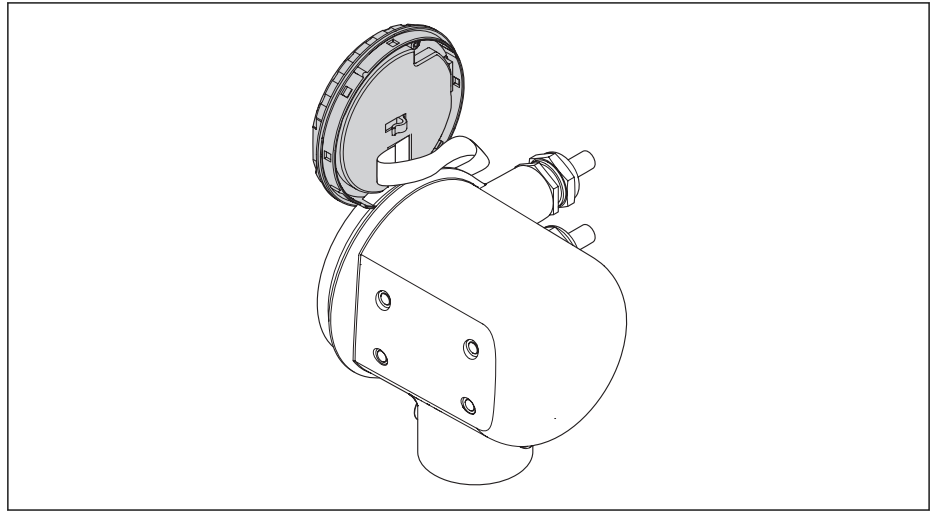

A0017375

3. Setting the write protection switch (WP) on the main electronics module to the ON position enables the hardware write protection. Setting the write protection switch (WP) on the main electronics module to the OFF position (factory setting) disables the hardware write protection.
 - ↳ If hardware write protection is enabled, the **Locking status** parameter displays the **Hardware locked** option (→ 83). In addition, on the local display the -symbol appears in front of the parameters in the header of the operational display and in the navigation view.

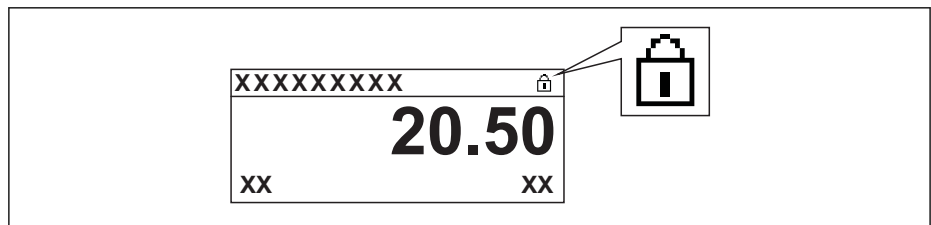

A0015870

If hardware write protection is disabled, no option is displayed in the **Locking status** parameter (→ 83). On the local display, the -symbol disappears from in front of the parameters in the header of the operational display and in the navigation view.

4. Feed the cable into the gap between the housing and electronics module and plug the display module into the electronics compartment in the desired direction until it engages.
5. Screw down the electronics compartment cover.

11 Operation

11.1 Reading device locking status

The write protection types that are currently active can be determined using the **Locking status** parameter.

Navigation

"Operation" menu → Locking status

Function scope of "Locking status" parameter

Options	Description
None	The access status displayed in " Access status display " parameter applies (→ 47). Only appears on local display.
Hardware locked	The DIP switch for hardware locking is activated on the main electronics module. This locks write access to the parameters (→ 81).
Temporarily locked	Write access to the parameters is temporarily locked on account of internal processes running in the device (e.g. data upload/download, reset etc.). Once the internal processing has been completed, the parameters can be changed once again.

11.2 Adjusting the operating language

See the "Commissioning" section for information on how to set the operating language (→ 55).

11.3 Configuring the display

- Basic settings for local display
- Advanced settings for local display (→ 71)

Navigation

"Operation" menu → Display

Submenu "Display" submenu

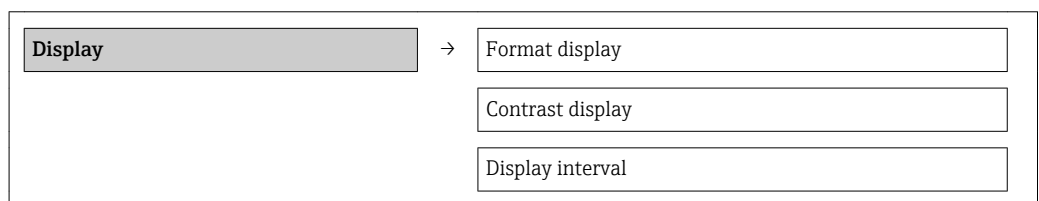

Parameter overview with brief description

Parameter	Description	Selection / User entry	Factory setting
Format display	Select how measured values are shown on the display.	<ul style="list-style-type: none"> ▪ 1 value, max. size ▪ 1 bargraph + 1 value ▪ 2 values ▪ 1 value large + 2 values ▪ 4 values 	1 value, max. size
Contrast display	Adjust local display contrast setting to ambient conditions (e.g. lighting or reading angle).	20 to 50 %	30 %

Parameter	Description	Selection / User entry	Factory setting
Backlight	Switch the local display backlight on and off.	<ul style="list-style-type: none"> ■ Disabled ■ Enabled 	Disabled
Display interval	Set time measured values are shown on display if display alternates between values.	1 to 10 s	5 s

11.4 Reading measured values

With the **Measured values** submenu , it is possible to read all the measured values.

"Diagnostics" menu → Measured values → Process variables → Mass flow

11.4.1 Process variables

The **Process variables** submenu contains all the parameters needed to display the current measured values for every process variable.

Navigation

"Diagnostics" menu → Measured values → Process variables

"Process variables" submenu

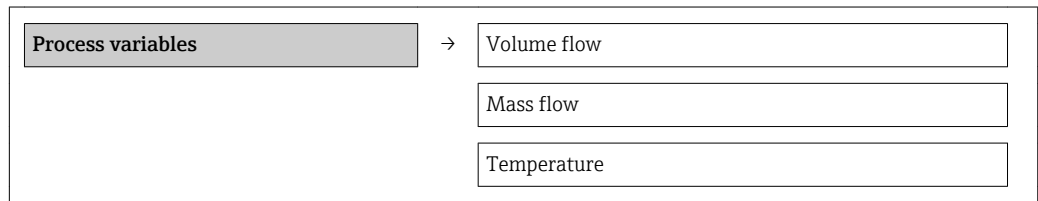

Parameter overview with brief description

Parameter	Description	User interface	Factory setting
Volume flow		Signed floating-point number	1 l/h
Mass flow		Signed floating-point number	1 kg/h
Temperature	Shows currently measured temperature.	Signed floating-point number	1 °C

11.4.2 Totalizer

The **Totalizer** submenu contains all the parameters needed to display the current measured values for every totalizer.

Navigation

"Diagnostics" menu → Measured values → Totalizer

"Totalizer" submenu

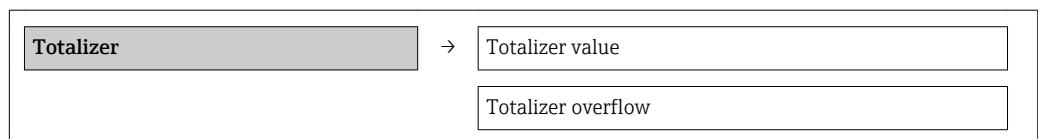

Parameter overview with brief description

Parameter	Prerequisite	Description	User interface	Factory setting
Totalizer value	In the Assign process variable parameter of Totalizer submenu one of the following options is selected: <ul style="list-style-type: none"> ▪ Volume flow ▪ Mass flow 	Displays the current totalizer counter value.	Signed floating-point number	0 m ³
Totalizer overflow	In the Assign process variable parameter of Totalizer submenu one of the following options is selected: <ul style="list-style-type: none"> ▪ Volume flow ▪ Mass flow 	Displays the current totalizer overflow.	-32 000.0 to 32 000.0	0

11.4.3 Input values

The **Input values** submenu guides you systematically to the individual input values.

Navigation

"Diagnostics" menu → Measured values → Input values

"Input values" submenu

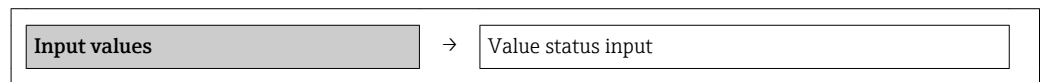

Parameter overview with brief description

Parameter	Description	User interface	Factory setting
Value status input	Displays the current input signal level.	<ul style="list-style-type: none"> ▪ High ▪ Low 	Low

11.4.4 Output values

The **Output values** submenu contains all the parameters needed to display the current measured values for every output.

Navigation

"Diagnostics" menu → Measured values → Output values

"Output values" submenu

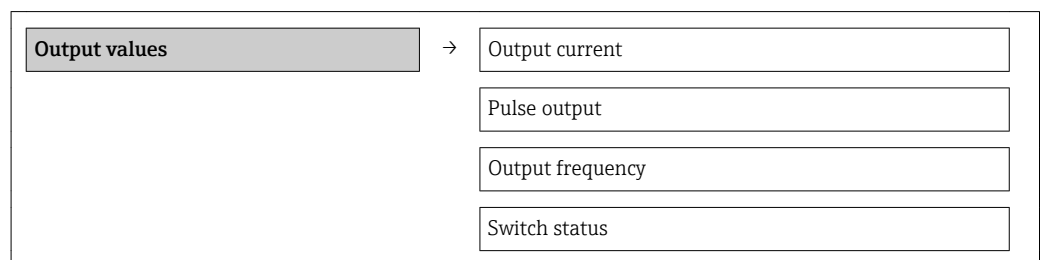



Parameter overview with brief description

Parameter	Description	User interface	Factory setting
Output current	Displays the current value currently calculated for the current output.	3.59 to 22.5 mA	3.59 mA
Output frequency	Displays the value currently measured for the frequency output.	0.0 to 1 250.0 Hz	0.0 Hz
Pulse output	Displays the value currently measured for the pulse output.	Positive floating-point number	0 Hz
Switch status	Displays the current switch output status.	<ul style="list-style-type: none"> ■ Open ■ Closed 	Open

11.5 Adapting the measuring device to the process conditions

The following are available for this purpose:

- Basic settings using the **Setup** menu(→  56)
- Advanced settings using the **Advanced setup** submenu(→  59)

11.6 Performing a totalizer reset

In the **Operation** menu the totalizers are reset:

- Control Totalizer
- Reset all totalizers

Navigation

"Operation" menu → Operation

Structure of the submenu

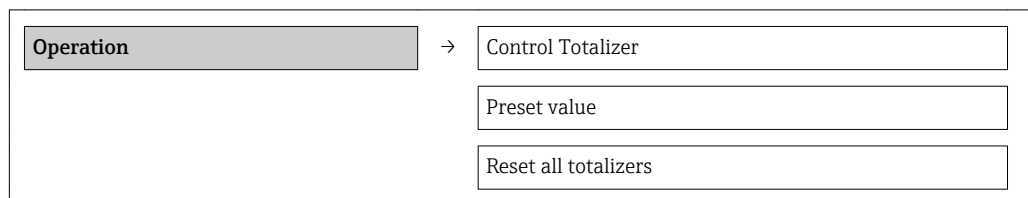

Parameter overview with brief description

Parameter	Description	Selection / User entry	Factory setting
Control Totalizer	Control totalizer value.	<ul style="list-style-type: none"> ■ Totalize ■ Reset + hold ■ Preset + hold ■ Reset + totalize ■ Preset + totalize 	Totalize
Preset value	Specify start value for totalizer.	Signed floating-point number	0 m ³
Reset all totalizers	Reset all totalizers to 0 and start.	<ul style="list-style-type: none"> ■ Cancel ■ Reset + totalize 	Cancel

11.6.1 Function scope of "Control Totalizer " parameter

Options	Description
Totalize	The totalizer is started.
Reset + hold	The totaling process is stopped and the totalizer is reset to 0.
Preset + hold	The totaling process is stopped and the totalizer is set to its defined start value from the Preset value parameter.
Reset + totalize	The totalizer is reset to 0 and the totaling process is restarted.
Preset + totalize	The totalizer is set to the defined start value in Preset value parameter and the totaling process is restarted.

11.6.2 Function scope of "Reset all totalizers" parameter

Options	Description
Cancel	No action is executed and the user exits the parameter.
Reset + totalize	Resets all totalizers to 0 and restarts the totaling process. This deletes all the flow values previously totalized.

11.7 Showing data logging

In the device, the extended function of the HistoROM must be enabled (order option for "Application package", option EA) so that the **Data logging** submenu appears. This contains all the parameters for the measured value history.

Function scope

- A total of 1000 measured values can be stored
- 4 logging channels
- Adjustable logging interval for data logging
- Display of the measured value trend for each logging channel in the form of a chart

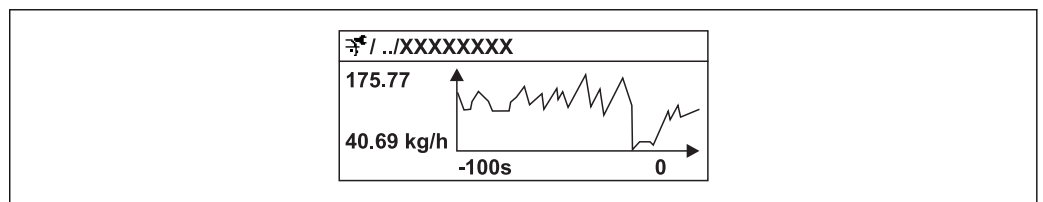

17 Chart of a measured value trend

- x-axis: depending on the number of channels selected displays 250 to 1000 measured values of a process variable.
- y-axis: displays the approximate measured value span and constantly adapts this to the ongoing measurement.

i If the length of the logging interval or the assignment of the process variables to the channels is changed, the content of the data logging is deleted.

Navigation

"Diagnostics" menu → Data logging

"Data logging" submenu

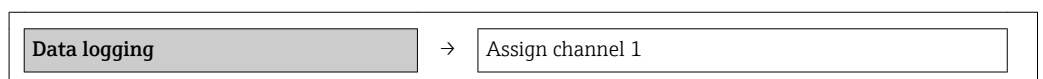

	Assign channel 2
	Assign channel 3
	Assign channel 4
	Logging interval
	Clear logging data

Parameter overview with brief description

Parameter	Description	Selection / User entry	Factory setting
Assign channel 1	Assign process variable to logging channel.	<ul style="list-style-type: none"> ■ Off ■ Volume flow ■ Mass flow ■ Temperature ■ Current output 	Off
Assign channel 2	Assign process variable to logging channel.	Picklist (see Assign chan. 1 parameter)	Off
Assign channel 3	Assign process variable to logging channel.	Picklist (see Assign chan. 1 parameter)	Off
Assign channel 4	Assign process variable to logging channel.	Picklist (see Assign chan. 1 parameter)	Off
Logging interval	Define the logging interval for data logging. This value defines the time interval between the individual data points in the memory.	1.0 to 3 600.0 s	10.0 s
Clear logging data	Clear the entire logging data.	<ul style="list-style-type: none"> ■ Cancel ■ Clear data 	Cancel

12 Diagnostics and troubleshooting

12.1 General troubleshooting







For local display

Problem	Possible causes	Remedy
Local display dark and no signal output at current output (0 mA)	Supply voltage does not match that specified on the nameplate.	Apply the correct supply voltage (→ 28).
Local display dark and no signal output at current output (0 mA)	Supply voltage has incorrect polarity.	Reverse polarity of supply voltage.
Local display dark and no signal output at current output (0 mA)	No contact between connecting cables and terminals.	Check the connection of the cables and correct if necessary.
Local display dark and no signal output at current output (0 mA)	Terminals are not plugged into the electronics module correctly.	Check terminals.
Local display dark and no signal output at current output (0 mA)	Electronics module is defective.	Order spare part (→ 105).
Local display is dark, but signal output is within the valid current range (3.6 to 22 mA)	Display is set too bright or too dark.	<ul style="list-style-type: none"> ▪ Set the display brighter by simultaneously pressing $\square + \square$. ▪ Set the display darker by simultaneously pressing $\square + \square$.
Local display is dark, but signal output is within the valid current range (3.6 to 22 mA)	Ribbon cable of the display module is not plugged in correctly.	Insert the plug correctly into the main electronics module and display module.
Local display is dark, but signal output is within the valid current range (3.6 to 22 mA)	Display module is defective.	Order spare part (→ 105).
Text on local display appears in a foreign language and cannot be understood.	Incorrect operating language is configured.	<ol style="list-style-type: none"> 1. Press $\square + \square$ for 2 s ("home position"). 2. Press \square. 3. Set the desired language in the Language parameter.

For output signals

Problem	Possible causes	Remedy
Signal output outside the valid current range (< 3.6 mA or > 22 mA)	Main electronics module is defective.	Order spare part (→ 105).
Device shows correct value on local display, but signal output is incorrect, though in the valid current range.	Configuration error	Check and correct parameter configuration.
Device measures incorrectly.	Configuration error or device is operated outside the application.	<ol style="list-style-type: none"> 1. Check and correct parameter configuration. 2. Observe limit values specified in the "Technical Data".

For access

Problem	Possible causes	Remedy
No write access to parameters	Hardware write protection enabled	Set the write protection switch on the main electronics module to the OFF position (→  81).
No write access to parameters	Current user role has limited access authorization	1. Check user role (→  47). 2. Enter correct customer-specific access code (→  47).
No connection via HART protocol	Missing or incorrectly installed communication resistor.	Install the communication resistor (250 Ω) correctly. Observe the maximum load (→  112).
No connection via HART protocol	Commubox <ul style="list-style-type: none"> ▪ Connected incorrectly ▪ Configured incorrectly ▪ Drivers not installed correctly ▪ USB or COM interface on computer configured incorrectly 	Observe the documentation for the Commubox.  FXA 195 HART: Document "Technical Information" TI00404F
No connection via service interface (CDI)	Incorrect configuration of USB interface on PC or driver not installed correctly.	Observe the documentation for the Commubox.  FXA 291 HART: Document "Technical Information" TI00405C

12.2 Diagnostic information on local display

12.2.1 Diagnostic message

Faults detected by the self-monitoring system of the measuring device are displayed as a diagnostic message in alternation with the operational display.

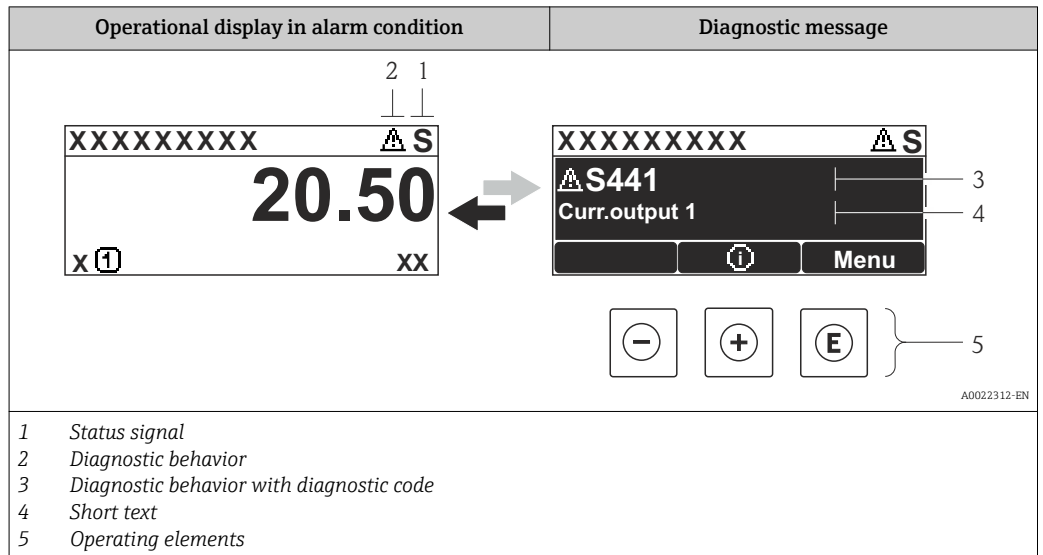

If two or more diagnostic events are pending simultaneously, only the message of the diagnostic event with the highest priority is shown.

- i** Other diagnostic events that have occurred can be displayed in the **Diagnostics** menu :
 - Via parameters (→ 99)
 - Via submenus (→ 100)



Status signals

The status signals provide information on the state and reliability of the device by categorizing the cause of the diagnostic information (diagnostic event).

- i** The status signals are categorized according to VDI/VDE 2650 and NAMUR Recommendation NE 107: F = Failure, C = Function Check, S = Out of Specification, M = Maintenance Required

Symbol	Meaning
F <small>A0013956</small>	Failure A device error has occurred. The measured value is no longer valid.
C <small>A0013959</small>	Function check The device is in service mode (e.g. during a simulation).
S <small>A0013958</small>	Out of specification The device is operated: <ul style="list-style-type: none"> ▪ Outside its technical specification limits (e.g. outside the process temperature range) ▪ Outside of the configuration carried out by the user (e.g. maximum flow in parameter 20 mA value)
M <small>A0013957</small>	Maintenance required Maintenance is required. The measured value is still valid.

Diagnostic behavior



Symbol	Meaning
 A0013961	Alarm <ul style="list-style-type: none">▪ Measurement is interrupted.▪ Signal outputs and totalizers assume the defined alarm condition.▪ A diagnostic message is generated.
 A0013962	Warning <p>Measurement is resumed. The signal outputs and totalizers are not affected. A diagnostic message is generated.</p>

Diagnostic information

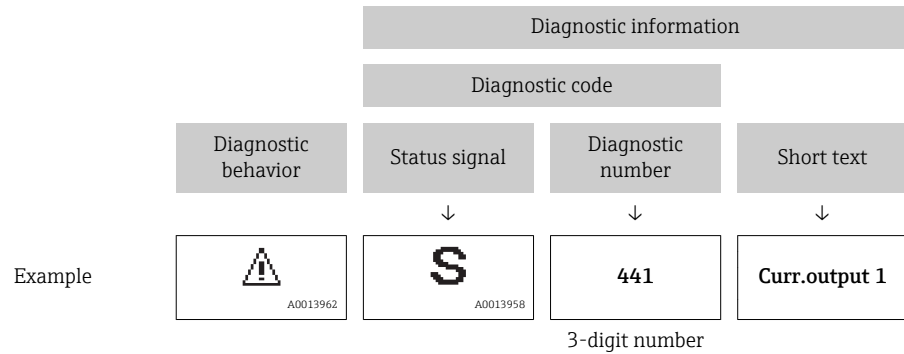
The fault can be identified using the diagnostic information. The short text helps you by providing information about the fault. In addition, the corresponding symbol for the diagnostic behavior is displayed in front of the diagnostic information on the local display.



Operating elements

Key	Meaning
 A0013970	Plus key <i>In a menu, submenu</i> Opens the message about the remedial measures.
 A0013952	Enter key <i>In a menu, submenu</i> Opens the operating menu.

12.2.2 Calling up remedial measures

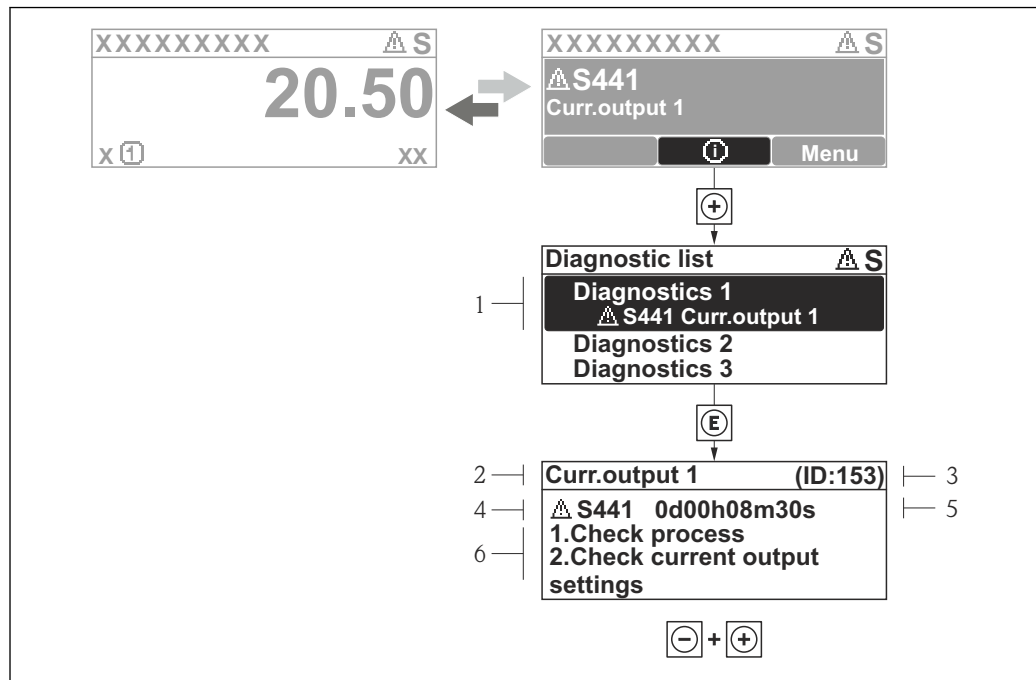

18 Message for remedial measures

- 1 Diagnostic information
- 2 Short text
- 3 Service ID
- 4 Diagnostic behavior with diagnostic code
- 5 Operation time of occurrence
- 6 Remedial measures

The user is in the diagnostic message.

1. Press **+** (**i** symbol).
 - ↳ The **Diagnostic list** submenu
2. Select the desired diagnostic event with **+** or **-** and press **⏎**.
 - ↳ The message for the remedial measures for the selected diagnostic event opens.
3. Press **-** + **+** simultaneously.
 - ↳ The message for the remedial measures closes.

The user is in the **Diagnostics** menu on a diagnostic event entry, e.g. in the **Diagnostic list** submenu or **Previous diagnostics** parameter.

1. Press **⏎**.
 - ↳ The message for the remedial measures for the selected diagnostic event opens.
2. Press **-** + **+** simultaneously.
 - ↳ The message for the remedial measures closes.

12.3 Diagnostic information in FieldCare

12.3.1 Diagnostic options

Any faults detected by the measuring device are displayed on the home page of the operating tool once the connection has been established.

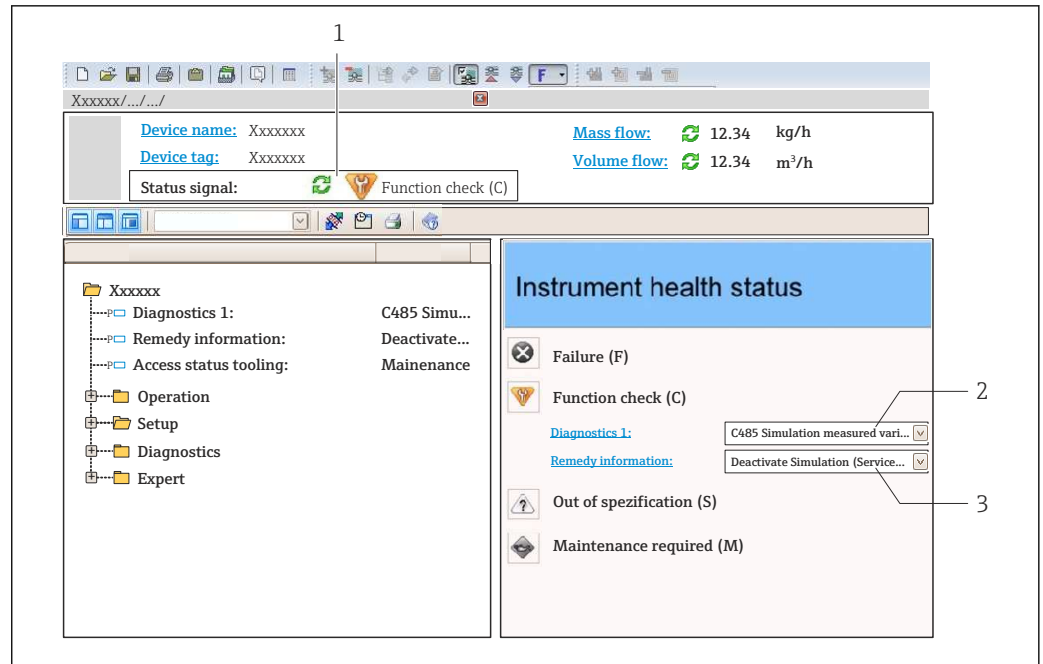

- 1 Status area with status signal (→ 91)
- 2 Diagnostic information (→ 93)
- 3 Remedial measures with Service ID

i In addition in the **Diagnostics** menu diagnostic events that have occurred can be displayed:

- Via parameters (→ 99)
- Via submenu (→ 100)

12.3.2 Calling up remedial measures

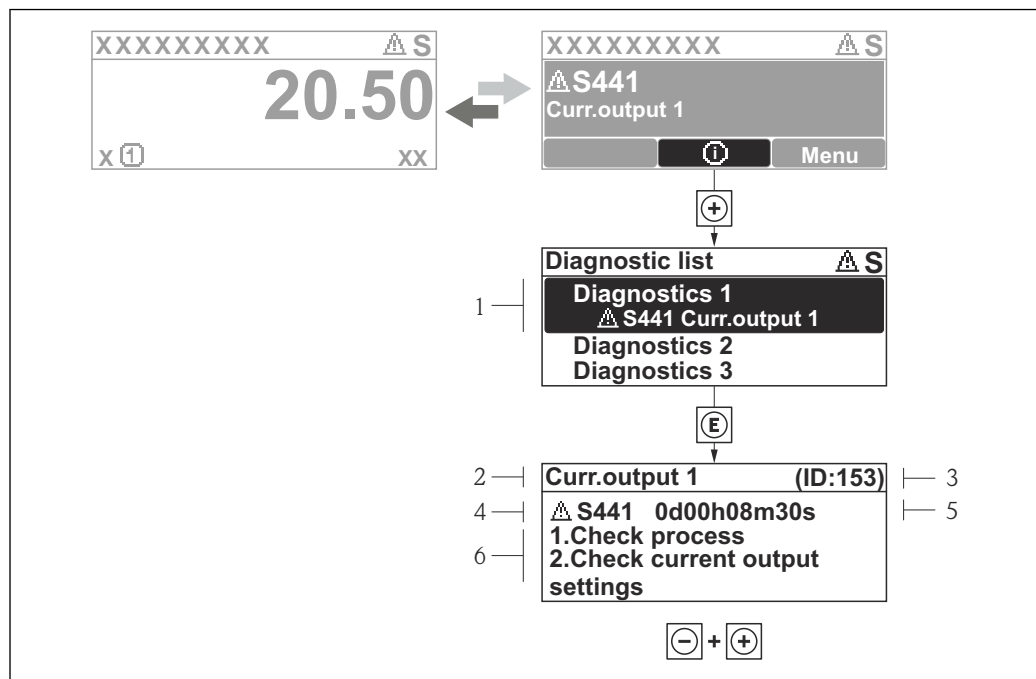

A0022311-EN

19 Message for remedial measures

- 1 Diagnostic information
- 2 Short text
- 3 Service ID
- 4 Diagnostic behavior with diagnostic code
- 5 Operation time of occurrence
- 6 Remedial measures

The user is in the diagnostic message.

1. Press **+** (ⓘ symbol).
 - ↳ The **Diagnostic list** submenu
2. Select the desired diagnostic event with **+** or **-** and press **⏎**.
 - ↳ The message for the remedial measures for the selected diagnostic event opens.
3. Press **-** + **+** simultaneously.
 - ↳ The message for the remedial measures closes.

The user is in the **Diagnostics** menu on a diagnostic event entry, e.g. in the **Diagnostic list** submenu or **Previous diagnostics** parameter.

1. Press **⏎**.
 - ↳ The message for the remedial measures for the selected diagnostic event opens.
2. Press **-** + **+** simultaneously.
 - ↳ The message for the remedial measures closes.

12.4 Adapting the diagnostic information

12.4.1 Adapting the diagnostic behavior

Each item of diagnostic information is assigned a specific diagnostic behavior at the factory. The user can change this assignment for certain diagnostics information in the **Diagnostic behavior** submenu.

"Expert" menu → System → Diagnostic handling → Diagnostic behavior

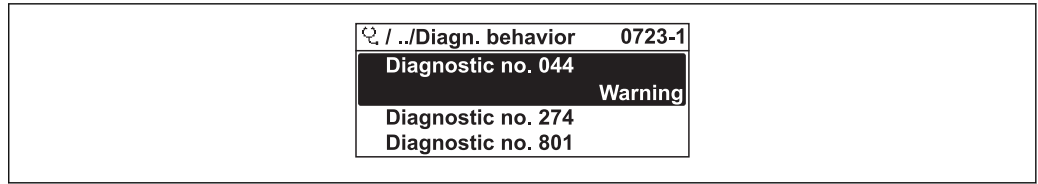

A0014048-EN

20 Using the example of the local display

You can assign the following options to the diagnostic number as the diagnostic behavior:

Options	Description
Alarm	Measurement is interrupted. The signal outputs assume the defined alarm condition. A diagnostics message is generated.
Warning	The device continues to measure. A diagnostics message is generated.
Logbook entry only	The device continues to measure. The diagnostic message is entered in the Event logbook (events list) submenu only and is not displayed in alternation with the measured value display.
Off	The diagnostic event is ignored, and no diagnostic message is generated or entered.

12.5 Overview of diagnostic information

i The amount of diagnostic information and the number of measured variables affected increase if the measuring device has one or more application packages.

Diagnostic number	Short text	Repairing action	Status signal from the factory	Diagnostic behaviour from the factory
Diagnostic of sensor				
004	Sensor	Change sensor	F	Alarm
082	Data storage	1. Insert DAT module 2. Change DAT module	F	Alarm
083	Memory content	1. Restart device 2. Check or change DAT module 3. Contact service	F	Alarm
Diagnostic of electronic				
242	Software incompatible	1. Check software 2. Flash or change main electronics module	F	Alarm
252	Modules incompatible	1. Check electronic modules 2. Change I/O or main electronic module	F	Alarm
261	Electronic modules	1. Restart device 2. Check electronic modules 3. Change I/O Modul or main electronics	F	Alarm
262	Module connection	1. Check module connections 2. Change electronic modules	F	Alarm
270	Main electronic failure	Change main electronic module	F	Alarm
271	Main electronic failure	1. Restart device 2. Change main electronic module	F	Alarm
272	Main electronic failure	1. Restart device 2. Contact service	F	Alarm
273	Main electronic failure	1. Emergency operation via display 2. Change main electronics	F	Alarm



Diagnostic number	Short text	Repairing action	Status signal from the factory	Diagnostic behaviour from the factory
275	I/O module failure	Change I/O module	F	Alarm
276	I/O module failure	1. Restart device 2. Change I/O module	F	Alarm
282	Data storage	1. Restart device 2. Contact service	F	Alarm
283	Memory content	1. Transfer data or reset device 2. Contact service	F	Alarm
311	Electronic failure	1. Transfer data or reset device 2. Contact service	F	Alarm
311	Electronic failure	Maintenance required! 1. Do not perform reset 2. Contact service	M	Warning
Diagnostic of configuration				
410	Data transfer	1. Check connection 2. Retry data transfer	F	Alarm
411	Up-/download active	Up-/download active, please wait	C	Warning
431	Trim 1	Carry out trim	C	Warning
437	Configuration incompatible	1. Restart device 2. Contact service	F	Alarm
437	Configuration incompatible	1. Transfer data or reset device 2. Contact service	C	Alarm
438	Dataset	1. Check data set file 2. Check device configuration 3. Up- and download new configuration	M	Warning
441	Current output 1	1. Check process 2. Check current output settings	S	Warning ¹⁾
442	Frequency output	1. Check process 2. Check frequency output settings	S	Warning ¹⁾
443	Pulse output	1. Check process 2. Check pulse output settings	S	Warning ¹⁾
453	Flow override	Deactivate flow override	C	Warning
484	Simulation failure mode	Deactivate simulation	C	Alarm
485	Simulation measured variable	Deactivate simulation	C	Warning
491	Simulation current output 1	Deactivate simulation	C	Warning
492	Simulation frequency output	Deactivate simulation frequency output	C	Warning
493	Simulation pulse output	Deactivate simulation pulse output	C	Warning
494	Switch output simulation	Deactivate simulation switch output	C	Warning
495	Simulation diagnostic event	Deactivate simulation	C	Warning
496	Simulation status input	Deactivate simulation status input	C	Warning
Diagnostic of process				
803	Current loop	1. Check wiring 2. Change I/O module	F	Alarm

Diagnostic number	Short text	Repairing action	Status signal from the factory	Diagnostic behaviour from the factory
832	Electronic temperature too high	Reduce ambient temperature	S	Warning
833	Electronic temperature too low	Increase ambient temperature	S	Warning
834	Process temperature too high	Reduce process temperature	S	Warning
835	Process temperature too low	Increase process temperature	S	Warning
841	Flow rate	1. Check process cond. 2. Increase system pressure	S	Alarm
842	Process limit	Low flow cut off active! 1. Check low flow cut off configuration	S	Warning
861	Delta temperature	1. Check flow rate 2. Change electronic	S	Alarm
862	Partly filled pipe	1. Check for gas in process 2. Adjust detection limits	S	Warning

1) Diagnostic status is changeable.

12.6 Pending diagnostic messages

The **Diagnostics** menu allows the user to view the current diagnostic event and the previous diagnostic event separately.

-  To call up the measures to rectify a diagnostic event:
 - Via local display (→  94)
 - Via "FieldCare" operating tool (→  94)

-  Other pending diagnostic events can be displayed in the **Diagnostic list** submenu (→  100)

Navigation

"Diagnostics" menu

Structure of the submenu

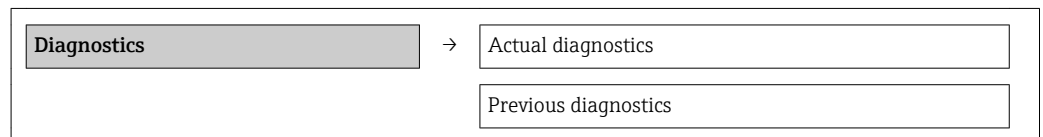

Parameter overview with brief description

Parameter	Prerequisite	Description	User interface	Factory setting
Actual diagnostics	1 diagnostic event has occurred.	Displays the current diagnostic event along with the diagnostic information.  If two or more messages occur simultaneously, the message with the highest priority is shown on the display.	Symbol for diagnostic behavior, diagnostic code and short message.	–
Previous diagnostics	2 diagnostic events have already occurred.	Displays the diagnostic event that occurred prior to the current diagnostic event along with the diagnostic information.	Symbol for diagnostic behavior, diagnostic code and short message.	–

12.7 Diagnostic list

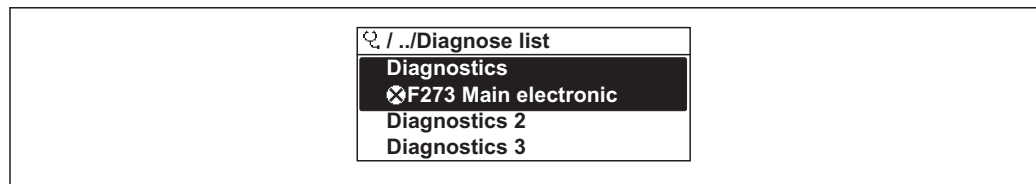

In the **Diagnostic list** submenu up to 5 currently pending diagnostic events can be displayed along with the related diagnostic information. If more than 5 diagnostic events are pending, the events with the highest priority are shown on the display.

"Diagnostics" menu → Diagnostic list → Diagnostics 1



A0014006-EN

 21 Using the example of the local display

-  To call up the measures to rectify a diagnostic event:
- Via local display (→  94)
 - Via "FieldCare" operating tool (→  94)

12.8 Event logbook

12.8.1 Event history

A chronological overview of the event messages that have occurred is provided in the **Events list** submenu.

"Diagnostics" menu → Event logbook → Filter options → Events list

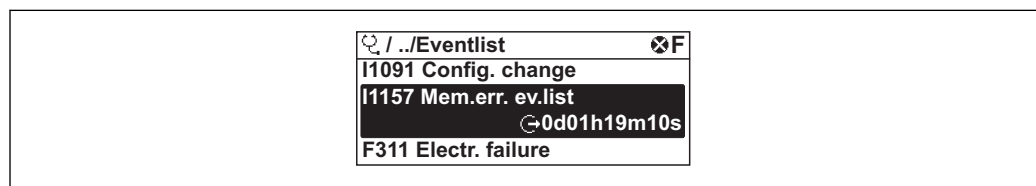



A0014008-EN



 22 Using the example of the local display

A maximum of 20 event messages can be displayed in chronological order. If the advanced HistoROM function is enabled in the device (order code for "Application packages", option EA), up to 100 entries can be displayed.



The event history includes entries for:

- Diagnostic events (→  97)
- Information events (→  101)

In addition to the operation time of its occurrence, each event is also assigned a symbol that indicates whether the event has occurred or is ended:

- Diagnostic event
 - : Occurrence of the event
 - : End of the event
- Information event
 - : Occurrence of the event

 To call up the measures to rectify a diagnostic event:

- Via local display (→  94)
- Via "FieldCare" operating tool (→  94)

 For filtering the displayed event messages (→  101)

12.8.2 Filtering the event logbook

Using the **Filter options** parameter, you can define which category of event messages is displayed in the **Events list** submenu.

"Diagnostics" menu → Event logbook → Filter options

Filter categories

- All
- Failure (F)
- Function check (C)
- Out of specification (S)
- Maintenance required (M)
- Information (I)

12.8.3 Overview of information events

Unlike a diagnostic event, an information event is displayed in the event logbook only and not in the diagnostic list.

Info number	Info name
I1000	----- (Device ok)
I1089	Power on
I1090	Configuration reset
I1091	Configuration changed
I1092	Trend data deleted
I1110	Write protection switch changed
I1137	Electronic changed
I1151	History reset
I1154	Reset terminal voltage min/max
I1155	Reset electronic temperature
I1156	Memory error trend
I1157	Memory error event list
I1185	Display backup done
I1186	Restore via display done

Info number	Info name
I1187	Settings downloaded with display
I1188	Display data cleared
I1189	Backup compared
I1227	Sensor emergency mode activated
I1228	Sensor emergency mode failed
I1256	Display: access status changed
I1264	Safety sequence aborted
I1335	Firmware changed
I1397	Fieldbus: access status changed
I1398	CDI: access status changed

12.9 Resetting the measuring device

Using the **Device reset** parameter it is possible to reset the entire device configuration or some of the configuration to a defined state.

"Setup" menu → Advanced setup → Administration

Function scope of "Device reset" parameter

Options	Description
Cancel	No action is executed and the user exits the parameter.
To delivery settings	Every parameter for which a customer-specific default setting was ordered is reset to this customer-specific value. All other parameters are reset to the factory setting.  This option is not visible if no customer-specific settings have been ordered.
Restart device	The restart resets every parameter whose data are in the volatile memory (RAM) to the factory setting (e.g. measured value data). The device configuration remains unchanged.
History reset	Every parameter is reset to its factory setting.

12.10 Device information

The **Device information** submenu contains all the parameters that display different information for identifying the device.

Navigation

"Diagnostics" menu → Device information

Device information	→	Device tag
		Serial number
		Firmware version
		Device name
		Order code
		Extended order code 1
		Extended order code 2

	Extended order code 3
	ENP version



Parameter overview with brief description

Parameter	Description	User interface	Factory setting
Device tag	Enter tag for measuring point.	Max. 32 characters, such as letters, numbers or special characters (e.g. @, %, /)	t-mass
Serial number	Displays the serial number of the measuring device.	Max. 11-digit character string comprising letters and numbers.	79AFF16000 ¹⁾
Firmware version	Displays the device firmware version installed.	Character string with the following format: xx.yy.zz	01.00 ¹⁾
Device name	Displays the name of the transmitter.	Character string composed of letters, numbers and certain punctuation marks.	t-mass T 150
Order code	Displays the device order code.	Character string composed of letters, numbers and certain punctuation marks	-
Extended order code 1	Displays the 1st part of the extended order code.	Character string	-
Extended order code 2	Displays the 2nd part of the extended order code.	Character string	-
Extended order code 3	Displays the 3rd part of the extended order code.	Character string	-
ENP version	Displays the version of the electronic nameplate.	Character string in the format xx.yy.zz	2.02.00 ¹⁾

1) This information varies depending on the device. Only an example is given here.

12.11 Firmware history

Release date	Firmware version	Order code for "Firmware version"	Firmware changes	Documentation type	Documentation
12.2013	01.00.zz	Option 78	Original firmware	Operating Instructions	BA01260D/06/EN/01.13

 Flashing the firmware to the current version or to the previous version is possible via the service interface (CDI) (→  122).

 For the compatibility of the firmware version with the previous version, the installed device description files and operating tools, observe the information about the device in the "Manufacturer's information" document.

-  The manufacturer's information is available:
- In the Download Area of the Endress+Hauser Internet site: www.endress.com → Download
 - Specify the following details:
 - Product root: e.g. 6TAB
 - Text search: Manufacturer's information
 - Search range: documentation

13 Maintenance

13.1 Maintenance tasks

No special maintenance work is required.

13.1.1 Exterior cleaning

When cleaning the exterior of measuring devices, always use cleaning agents that do not attack the surface of the housing or the seals.

13.1.2 Interior cleaning

Cleaning the transducer

In applications with unclean fluids, it is advisable to inspect and clean the device regularly to minimize measured errors caused by fouling or buildup.



The inspection and cleaning intervals depend on the field of application.

NOTICE

The use of unsuitable equipment or cleaning liquids can damage the transducer.

- ▶ Do not use pigs to clean the pipe.
- ▶ Use an oil-free cleaning agent that does not form a film to clean the sensor. Gently clean the surface using a soft brush.
- ▶ When cleaning make sure that the cap is not damaged.
- ▶ Never use cleaning agents that can corrode the material and the seal.

Sensor-specific information:

- Follow the safety instructions when removing the sensor (→  9).
- Follow the instructions in the "Installation" section when removing the sensor (→  25).

13.2 Measuring and test equipment

Endress+Hauser offers a wide variety of measuring and test equipment, such as W@M or device tests.

 Your Endress+Hauser Sales Center can provide detailed information on the services.

 For a list of some of the measuring and test equipment, refer to the "Accessories" chapter of the "Technical Information" document for the device.

13.3 Endress+Hauser services

Endress+Hauser offers a wide variety of services for maintenance such as recalibration, maintenance service or device tests.

 Your Endress+Hauser Sales Center can provide detailed information on the services.

14 Repair

14.1 General notes

Repair and conversion concept

The Endress+Hauser repair and conversion concept provides for the following:

- The measuring devices have a modular design.
- Spare parts are grouped into logical kits with the associated Installation Instructions.
- Repairs are carried out by Endress+Hauser Service or by correspondingly trained customers.
- Certified devices can be converted into other certified devices by Endress+Hauser Service or at the factory only.

Notes for repair and conversion

For repair and modification of a measuring device, observe the following notes:

- Use only original Endress+Hauser spare parts.
- Carry out the repair according to the Installation Instructions.
- Observe the applicable standards, federal/national regulations, Ex documentation (XA) and certificates.
- Document every repair and each conversion and enter them into the *W@M* life cycle management database.

14.2 Spare parts

The URL for the *W@M Device Viewer* (www.endress.com/deviceviewer):

All the spare parts for the measuring device, along with the order code, are listed here and can be ordered. If available, users can also download the associated Installation Instructions.



Measuring device serial number:

- Is located on the device nameplate and the spare part overview sign.
- Can be read out via the **Serial number** parameter in the **Device information** submenu .

14.3 Endress+Hauser services



Contact your Endress+Hauser Sales Center for information on services and spare parts.

14.4 Return

The measuring device must be returned if repairs or a factory calibration are required, or if the wrong measuring device has been ordered or delivered. According to legal regulations, Endress+Hauser, as an ISO-certified company, is required to follow certain procedures when handling returned products that are in contact with medium.

To ensure swift, safe and professional device returns, please read the return procedures and conditions on the Endress+Hauser website at www.services.endress.com/return-material

14.5 Disposal

14.5.1 Removing the measuring device

1. Switch off the device.

2. **WARNING!** Danger to persons from process conditions. Beware of hazardous process conditions such as pressure in the measuring device, high temperatures or aggressive fluids.

Carry out the mounting and connection steps from the chapters "Mounting the measuring device" and "Connecting the measuring device" in the logically reverse sequence. Observe the safety instructions.

14.5.2 Disposing of the measuring device

WARNING

Danger to personnel and environment from fluids that are hazardous to health.

- ▶ Ensure that the measuring device and all cavities are free of fluid residues that are hazardous to health or the environment, e.g. substances that have permeated into crevices or diffused through plastic.

Observe the following notes during disposal:

- Observe valid federal/national regulations.
- Ensure proper separation and reuse of the device components.

15 Accessories





Various accessories, which can be ordered with the device or subsequently from Endress+Hauser, are available for the device. Detailed information on the order code in question is available from your local Endress+Hauser sales center or on the product page of the Endress+Hauser website: www.endress.com.

15.1 Device-specific accessories









15.1.1 For the transmitter

Accessories	Description
Weather protection cover	<p>Is used to protect the measuring device from the effects of the weather: e.g. rainwater, excess heating from direct sunlight or extreme cold in winter.</p> <p> For details, see Special Documentation SD00333F</p>

15.1.2 For the sensor

Accessories	Description
Mounting boss	<p>Mounting boss for t-mass insertion version with G$\frac{3}{4}$" or $\frac{3}{4}$" NPT compression fittings.</p> <p>Order code DK6MB-*</p>
Threadolet	<p>Threadolet for t-mass T 150 with union nut (<i>order code for "Process Connection", option TP1 and TS1</i>).</p> <p>Order code DK6001-*</p>
Dummy plug	<p>Dummy plug for threadolet.</p> <p>For couplings made of:</p> <ul style="list-style-type: none"> ▪ Stainless steel, 1.4404 similar to 316L ▪ Hastelloy AC22, 2.4602 similar to N06022
Safety chain	<p>For couplings in combination with PEEK clamping ferrules and pressures > 4.5 bar (65.27 psi) (→  24)</p>
Hot tap	<p>If the accessory is ordered as an extended option, only one particular set of standard features is available.</p> <p> Can only be used in conjunction with:</p> <ul style="list-style-type: none"> ▪ The standard version (<i>order code for "Insertion Length", option L6 "330mm 13"</i>) ▪ Process connections with clamping ferrules in PEEK <p>Low pressure, <i>order code for "Accessories enclosed", options PK, PL</i></p> <p>Mounting set contains weld-in nipple (process connection), sensor connection with safety chain and ball valve. To insert or remove the sensor at process pressures up to max. 4.5 bar g (65 psi).</p> <p>High pressure, <i>order code for "Accessories enclosed", options PM, PN</i></p> <p>Mounting set contains weld-in nipple (process connection), sensor connection, ball valve and extractor assembly. To insert or remove the sensor at process pressures up to max. 16 bar g (235 psi).</p> <p> For details, see Installation Instructions EA00109D</p> <p> If the accessory is ordered separately, individual combinations can be selected.</p> <p>Order code DK6HT-*</p>

15.2 Communication-specific accessories

Accessories	Description
Commubox FXA195 HART	For intrinsically safe HART communication with FieldCare via the USB interface.  For details, see "Technical Information" TI00404F
Commubox FXA291	Connects Endress+Hauser field devices with a CDI interface (= Endress+Hauser Common Data Interface) and the USB port of a computer or laptop.  For details, see "Technical Information" TI00405C
HART Loop Converter HMX50	Is used to evaluate and convert dynamic HART process variables to analog current signals or limit values.  For details, see "Technical Information" TI00429F and Operating Instructions BA00371F
Wireless HART adapter SWA70	Is used for the wireless connection of field devices. The WirelessHART adapter can be easily integrated into field devices and existing infrastructures, offers data protection and transmission safety and can be operated in parallel with other wireless networks with minimum cabling complexity.  For details, see Operating Instructions BA00061S
Fieldgate FXA320	Gateway for the remote monitoring of connected 4-20 mA measuring devices via a Web browser.  For details, see "Technical Information" TI00025S and Operating Instructions BA00053S
Fieldgate FXA520	Gateway for the remote diagnostics and remote configuration of connected HART measuring devices via a Web browser.  For details, see "Technical Information" TI00025S and Operating Instructions BA00051S
Field Xpert SFX350	Field Xpert SFX350 is a mobile computer for commissioning and maintenance. It enables efficient device configuration and diagnostics for HART and FOUNDATION fieldbus devices in the non-Ex area .  For details, see Operating Instructions BA01202S
Field Xpert SFX370	Field Xpert SFX370 is a mobile computer for commissioning and maintenance. It enables efficient device configuration and diagnostics for HART and FOUNDATION fieldbus devices in the non-Ex area and the Ex area .  For details, see Operating Instructions BA01202S

15.3 Service-specific accessories

Accessories	Description
W@M	<p>Life cycle management for your plant</p> <p>W@M supports you with a wide range of software applications over the entire process: from planning and procurement, to the installation, commissioning and operation of the measuring devices. All the relevant device information, such as the device status, spare parts and device-specific documentation, is available for every device over the entire life cycle.</p> <p>The application already contains the data of your Endress+Hauser device. Endress+Hauser also takes care of maintaining and updating the data records.</p> <p>W@M is available:</p> <ul style="list-style-type: none"> ▪ Via the Internet: www.endress.com/lifecyclemanagement ▪ On CD-ROM for local PC installation.
FieldCare	<p>FDT-based plant asset management tool from Endress+Hauser.</p> <p>It can configure all smart field units in your system and helps you manage them. By using the status information, it is also a simple but effective way of checking their status and condition.</p> <p> For details, see Operating Instructions BA00027S and BA00059S</p>

15.4 System components

Accessories	Description
Memograph M graphic display recorder	<p>The Memograph M graphic display recorder provides information on all relevant measured variables. Measured values are recorded correctly, limit values are monitored and measuring points analyzed. The data are stored in the 256 MB internal memory and also on a SD card or USB stick.</p> <p> For details, see "Technical Information" TI00133R and Operating Instructions BA00247R</p>

16 Technical data

16.1 Application

The measuring device is suitable for flow measurement of liquids only.

To ensure that the device remains in proper operating condition for its service life, use the measuring device only for media against which the process-wetted materials are adequately resistant.

16.2 Function and system design

Measuring principle	Mass flow measurement based on thermal measuring principle
Measuring system	<p>The device consists of a transmitter and a sensor.</p> <p>One device version is available: compact version - transmitter and sensor form a mechanical unit.</p> <p>For information on the structure of the device (→  12)</p>

16.3 Input

Measured variable	<p>Direct measured variables</p> <ul style="list-style-type: none"> ▪ Mass flow ▪ Medium temperature <p>Calculated measured variables</p> <p>Volume flow</p>
Measuring range	<p>The available measuring range depends on the size of the pipe.</p> <p>The following tables list the ranges available for water.</p> <p>Order code for "Calibration flow", option G (not verified)</p> <p>Specified measuring range up to 100 % (→  115)</p>

SI units for insertion version

DN	[kg/h]		[l/h]	
	min.	max.	min.	max.
[mm]				
40	226	22 600	226	22 600
50	352	35 200	352	35 200
65	596	59 600	596	59 600
80	902	90 200	902	90 200
100	1 410	141 000	1 410	141 000
150	3 170	317 000	3 170	317 000
200	5 640	564 000	5 640	564 000
400	22 600	2 260 000	22 600	2 260 000

DN	[kg/h]		[l/h]	
[mm]	min.	max.	min.	max.
600	50 700	5 070 000	50 700	5 070 000
800	90 200	9 020 000	90 200	9 020 000
1000	141 000	14 100 000 ¹⁾	141 000	14 100 000 ¹⁾

1) Full scale value calculated with 5 m/s, a density of 1000 kg/m³ and corresponding cross-section.

US units for insertion version

DN	[lb/h]		[gal/h]	
[in]	min.	max.	min.	max.
1½	497	49 700	60	6 000
2	777	77 700	93	9 300
2½	1310	131 000	158	15 800
3	1990	199 000	239	23 900
4	3 110	311 000	373	37 300
6	6 990	699 000	840	84 000
8	12 400	1 240 000	1 500	150 000
16	49 700	4 970 000	6 000	600 000
24	112 000	11 200 000	13 400	1 340 000
32	199 000	19 900 000	23 900	2 390 000
40	311 000	31 100 000 ¹⁾	37 300	3 730 000 ¹⁾

1) Full scale value calculated with 16.4 ft/s, a density of 62.42 lb/ft³ and corresponding cross-section.

Operable flow range 100 : 1

Input signal

Status input

Maximum input values	<ul style="list-style-type: none"> ▪ DC 30 V ▪ 6 mA
Response time	Adjustable: 5 to 200 ms
Input signal level	<ul style="list-style-type: none"> ▪ Low signal: DC -3 to +5 V ▪ High signal: DC 15 to 30 V
Assignable functions	<ul style="list-style-type: none"> ▪ Off ▪ Resetting the totalizer ▪ Flow override ▪ CIP/SIP mode

16.4 Output

Output signal

Current output

Current output	4-20 mA HART, active
Maximum output values	<ul style="list-style-type: none"> ▪ DC 24 V (open circuit voltage) ▪ 22 mA  If in Failure mode parameter the Defined value option is selected: 22.5 mA
Load	0 to 750 Ω
Resolution	16 Bit or 0.38 µA
Damping	Adjustable: 0 to 999 s
Assignable measured variables	<ul style="list-style-type: none"> ▪ Mass flow ▪ Volume flow ▪ Temperature

Pulse/frequency/switch output

Function	Can be set to pulse, frequency or switch output
Version	Passive, open collector
Maximum input values	<ul style="list-style-type: none"> ▪ DC 30 V ▪ 25 mA
Voltage drop	For 25 mA: ≤ DC2 V
Pulse output	
Pulse width	Adjustable: 0.5 to 2 000 ms → pulse rate:0 to 1 000 Pulse/s
Pulse value	Adjustable
Assignable measured variables	<ul style="list-style-type: none"> ▪ Off ▪ Volume flow ▪ Mass flow
Frequency output	
Maximum frequency	Adjustable: 0 to 1 000 Hz
Damping	Adjustable: 0 to 999 s
Pulse/pause ratio	1:1
Assignable measured variables	<ul style="list-style-type: none"> ▪ Off ▪ Volume flow ▪ Mass flow ▪ Temperature
Switch output	
Switching behavior	Binary, conductive or non-conductive
Switching delay	Adjustable: 0 to 100 s
Number of switching cycles	Unlimited
Assignable functions	<ul style="list-style-type: none"> ▪ Off ▪ On ▪ Diagnostic behavior ▪ Limit ▪ Status

Signal on alarm

Depending on the interface, failure information is displayed as follows:

Current output

4-20 mA

Failure mode	Selectable (as per NAMUR recommendation NE 43): <ul style="list-style-type: none"> ▪ Minimum value: 3.6 mA ▪ Maximum value: 22 mA ▪ Defined value: 3.59 to 22.5 mA ▪ Actual value ▪ Last valid value
---------------------	---

HART

Device diagnostics	Device condition can be read out via HART Command 48
---------------------------	--

Pulse/frequency/switch output

Pulse output	
Failure mode	Choose from: <ul style="list-style-type: none"> ▪ Actual value ▪ No pulses
Frequency output	
Failure mode	Choose from: <ul style="list-style-type: none"> ▪ Actual value ▪ Defined value: 0 to 1250 Hz ▪ 0 Hz
Switch output	
Failure mode	Choose from: <ul style="list-style-type: none"> ▪ Current status ▪ Open ▪ Closed

Local display

Plain text display	With information on cause and remedial measures
---------------------------	---

 Status signal as per NAMUR recommendation NE 107

Operating tool

- Via digital communication: HART protocol
- Via service interface

Plain text display	With information on cause and remedial measures
---------------------------	---

Ex connection data

 For detailed information about the Ex-rated connection values, refer to the Technical Information for the device on the CD-ROM provided

Low flow cut off

The switch points for low flow cut off are programmable.

Galvanic isolation

The following connections are galvanically isolated from each other:

- Outputs
- Power supply

Protocol-specific data

HART

Manufacturer ID	0x11
Device type ID	0x68
HART protocol revision	6.0
Device description files (DTM, DD)	Information and files under: www.endress.com
HART load	Min. 250 Ω
Dynamic variables	The measured variables can be freely assigned to the dynamic variables. Measured variables for PV (primary dynamic variable) <ul style="list-style-type: none"> ▪ Mass flow ▪ Volume flow ▪ Temperature Measured variables for SV, TV, QV (secondary, tertiary and quaternary dynamic variable) <ul style="list-style-type: none"> ▪ Mass flow ▪ Volume flow ▪ Temperature ▪ Totalizer

16.5 Power supply

Terminal assignment

(→  28)

Pin assignment, device plug

(→  29)

Supply voltage

DC 24 V (18 to 30 V)

The power supply circuit must comply with SELV/PELV requirements.

Power consumption

Transmitter

Order code for "Output, input"	Maximum power consumption
Option A: 4-20mA HART	4.0 W
Option B: 4-20mA HART, pulse/frequency/switch output	
Option K: Pulse/frequency/switch output	3.2 W
Option Q: 4-20mA HART, pulse/frequency/switch output, status input	4.0 W

Current consumption

Transmitter

Order code for "Output, input"	Maximum current consumption	Maximum switch-on current
Option A: 4-20mA HART	225 mA	< 2.5 A
Option B: 4-20mA HART, pulse/frequency/switch output		

Order code for "Output, input"	Maximum current consumption	Maximum switch-on current
Option K: Pulse/frequency/switch output	180 mA	
Option Q: 4-20mA HART, pulse/frequency/switch output, status input	225 mA	

Power supply failure

- Totalizer stops at the last value measured.
- Configuration is retained in the device memory.
- Error messages (incl. total operated hours) are stored.

Electrical connection

Terminals

Plug-in screw terminals for specified wire cross-sections

Cable entries

- Cable gland: M20 × 1.5 with cable ϕ 6 to 12 mm (0.24 to 0.47 in)
- Thread for cable entry:
 - NPT 1/2"
 - G 1/2"
- 1 × M12 connector (supply voltage, status input), 1 × M12 socket (4 to 20mA, pulse/frequency/switch output)

Cable specification

16.6 Performance characteristics

Reference operating conditions

- Reference fluid: water
- Reference temperature: +25 °C (+77 °F) [±2 °C (±4 °F)]
- Calibration systems traceable to national standards
- Accredited in accordance with ISO/IEC 17025

Maximum measured error

o.r. = of reading; o.f.s. = of full scale value

-  The full scale value depends on the nominal diameter of the measuring device.
- Full scale values of the specified measuring range

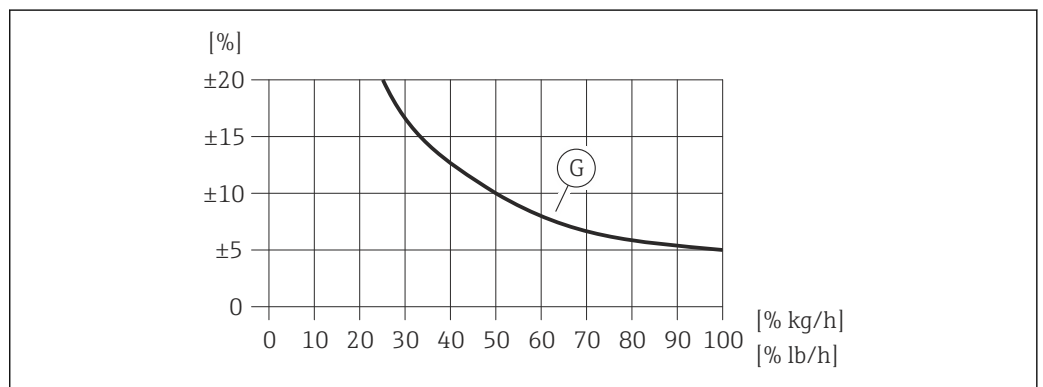

23 Maximum measured error (% mass flow) as % of full scale value. G: Order code for "Calibration flow" (not verified), see the following table

Order code for "Calibration flow" (not verified)	Accuracy	Description
G	Q =1 to 100 % ±5 %o.f.s. For DN 40 to 150 (1½ to 6") (under reference conditions)	This version is subject to neither a calibration nor a verification of measuring performance. ¹⁾
	For DN > 150 to 1000 (8 to 40"): Absolute measurement of the flow is not possible in this nominal diameter range.	The device measures the flow trend on a proportional basis. ¹⁾

1) The measured value can be adapted to plant conditions with the installation factor. Onsite adjustment is recommended for unfavorable inlet conditions or for fluids dissimilar to water.

 For detailed information about onsite adjustment, refer to the Operating Instructions for the device on the CD-ROM provided

Accuracy of outputs

Current output

Accuracy	Max. ±0.05 % o.f.s. or ±10 µA
-----------------	-------------------------------

Repeatability ±0.5 % of value for velocities > 0.2 m/s (0.66 ft/s)

Response time Typically < 3 s for 63 % of a given step change (in both directions)

Influence of medium temperature ±0.2 % o.r./K, deviating from the reference temperature (+25 °C (+77 °F))

16.7 Installation

"Mounting requirements" (→  18)

16.8 Environment



Ambient temperature range (→  24)

Temperature tables

 Observe the interdependencies between the permitted ambient and fluid temperatures when operating the device in hazardous areas.

 For detailed information about the temperature tables, refer to the Technical Information for the device on the CD-ROM provided

Storage temperature -40 to +80 °C (-40 to +176 °F), preferably at +20 °C (+68 °F)

Degree of protection	<p>Transmitter</p> <ul style="list-style-type: none"> ■ As standard: IP66/67, type 4X enclosure ■ When housing is open: IP20, type 1 enclosure ■ Display module: IP20, type 1 enclosure <p>Sensor IP66/67, type 4X enclosure</p>
Shock resistance	As per IEC/EN 60068-2-31
Vibration resistance	<p>Tests conducted:</p> <ul style="list-style-type: none"> ■ Vibration, sinusoidal IEC 60068-2-6: <ul style="list-style-type: none"> - 2 to 8.4 Hz with 3.5 mm (0.14 in) peak, - 8.4 to 500 Hz with 1 g peak, - 20 sweeps/axis, - 1 octave/min ■ Vibration, broad-band random IEC 60068-2-64: <ul style="list-style-type: none"> - 10 to 200 Hz with 0.003 g²/Hz, - 200 to 2 000 Hz with 0.001 g²/Hz (1.54 g rms), - 120 minutes/axis ■ Shock resistance IEC 60068-2-27: <ul style="list-style-type: none"> - 6 ms30 g, - 3 pos. + 3 neg. per axis
Electromagnetic compatibility (EMC)	<p>As per IEC/EN 61326.</p> <p> For details refer to the Declaration of Conformity.</p> <p>NAMUR recommendation 21 (NE 21) with restriction: interruption of supply voltage 20 ms not satisfied.</p>
16.9 Process	
Medium temperature range	<p>Sensor -20 to +100 °C (-4 to +212 °F)</p> <p>Seals (G thread only)</p> <ul style="list-style-type: none"> ■ HNBR: -20 to +100 °C (-4 to +212 °F) ■ EPDM: -20 to +100 °C (-4 to +212 °F) <p> Temperature-dependent density table as per NIST REFPROP Standard Reference (Database 23, Version 9.0)</p> <p>clamping ferrules</p> <ul style="list-style-type: none"> ■ PEEK: -20 to +100 °C (-4 to +212 °F) ■ 1.4404 (316L): -20 to +100 °C (-4 to +212 °F) ■ 2.4602 (AC22): -20 to +100 °C (-4 to +212 °F)
Process temperature range	<p>Hygiene applications:</p> <ul style="list-style-type: none"> ■ SIP process: 130 °C (266 °F) for max. one hour ■ Temperature gradient: max. 1 000 K/min
Pressure-temperature ratings	<p> An overview of the material load diagrams (pressure/temperature curves) for the process connections is provided in the "Technical Information" document for the device on the CD-ROM provided.</p>

Flow limit See "Measuring range" (→  110) section
The velocity in the measuring tube should not exceed 5 m/s (16.4 ft/s).

Pressure loss Negligible.

System pressure

NOTICE

Depending on version:

Observe information on nameplate.

- ▶ Max. 40 bar g (580 psi g)

WARNING

If the coupling is opened incorrectly under full process pressure, the sensor will shoot out. Therefore it must be ensured that the sensor does not accelerate to a dangerous exit velocity.

- ▶ Use a safety chain for pressures > 4.5 bar (65.27 psi) in combination with PEEK clamping ferrules (→  107).

WARNING

The sensor is exposed to high temperatures.

Risk of burns from hot surfaces or leaking medium!

- ▶ Before commencing work: allow the system and measuring device to cool to a safe temperature.

Thermal insulation

The maximum possible thickness of the thermal insulation layer is:

Order code for "Insertion Length", option L5 "110mm 4": 100 mm (3.94 in)

The following is recommended for thicker insulation layers:

Order code for "Insertion Length", option L6 "330mm 13": 320 mm (12.6 in)

NOTICE

Electronics can overheat on account of thermal insulation!

- ▶ Observe maximum permitted insulation height of the transmitter neck so that the transmitter head is completely free.

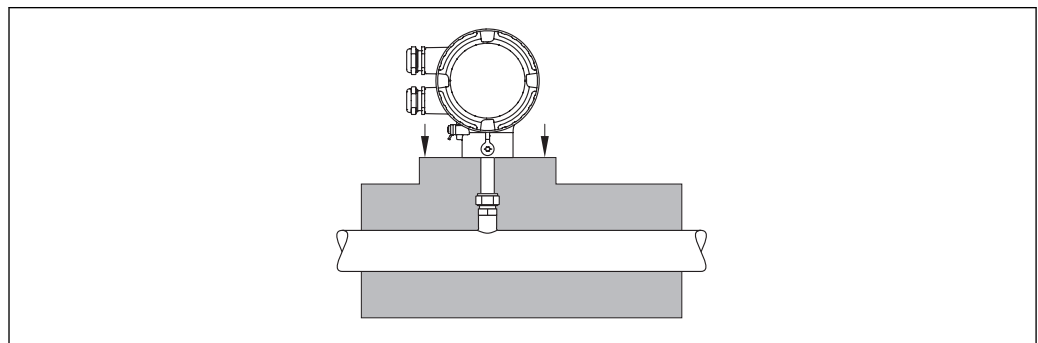

A0015763

16.10 Mechanical construction

Design, dimensions

 For the dimensions and installation lengths of the device, see the "Technical Information" document, "Mechanical construction" section

Weight

Compact version

- Including the transmitter
- Weight specifications apply to standard pressure ratings and without packaging material.

*Standard version**Weight in SI units*

Sensor length [mm]	Weight [kg]
Order code for "Insertion Length"	Order code for "Housing", option C "Compact, alu coated"
110	1.8
330	2.0

Weight in US units

Sensor length [in]	Weight [lbs]
Order code for "Insertion Length"	Order code for "Housing", option C "Compact, alu coated"
4	4.0
13	4.4

*Hygienic version**Weight in SI units*

Sensor length [mm]	Weight [kg]
Order code for "Insertion Length"	Order code for "Housing", option C "Compact, alu coated"
30 to 85	1.8

Weight in US units

Sensor length [in]	Weight [lbs]
Order code for "Insertion Length"	Order code for "Housing", option C "Compact, alu coated"
1 to 3	4.0

Accessories

Hot tap

Weight in SI units

Hot tap Version	Weight [kg]
Version with weld-in nipple (version V1)	2.2
Flanged version (version V2)	4.3
Extractor assembly	7.8

Weight in US units

Hot tap Version	Weight [lbs]
with retrofit adapter (version V1)	4.0
with weld-in nipple (version V2)	4.9
with flange/flange adapter (version V3)	9.5
Extractor assembly	17.5

Materials

Transmitter housing

Compact version

- Order code for "Housing", option A "Compact, alu coated": coated aluminum AlSi10Mg
- Window material: glass

Cable entries/cable glands

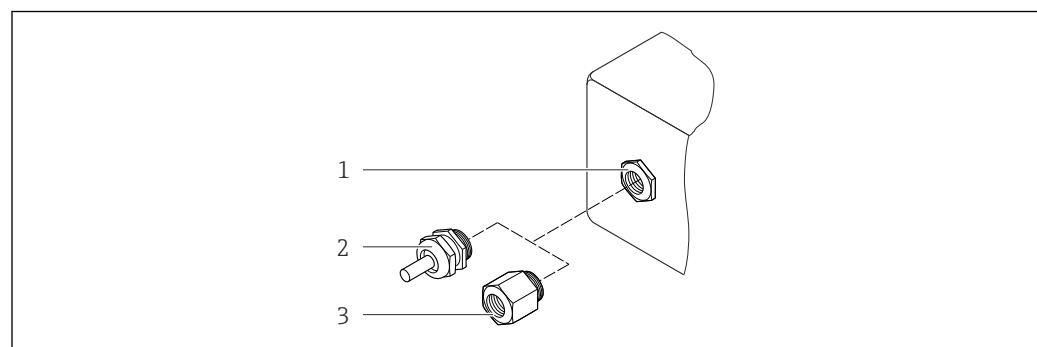

A0020640

24 Possible cable entries/cable glands

- 1 Cable entry in transmitter housing, wall-mount housing or connection housing with internal thread M20 x 1.5
- 2 Cable gland M20 x 1.5
- 3 Adapter for cable entry with internal thread G ½" or NPT ½"

Order code for "Housing", option A "Compact, alu coated"

Cable entry/cable gland	Type of protection	Material
Cable gland M20 × 1.5	For non-Ex and Ex	Plastic
Adapter for cable entry with internal thread G ½"		Nickel-plated brass
Adapter for cable entry with internal thread NPT ½"		

Connector

Electrical connection	Material
Connector M12 × 1	<ul style="list-style-type: none"> ▪ Socket: Stainless steel, 1.4404 (316L) ▪ Contact housing: Polyamide ▪ Contacts: Gold-plated brass

Sensor

Transducer

- Standard version
 - Stainless steel, 1.4404 (316/316L)
 - Hastelloy AC22, 2.4602 (N06022)
- Hygienic version:
 - Stainless steel, 1.4404 (316/316L), sensor tip made of Hastelloy AC22, 2.4602 (N06022)

Process connections

Standard version

Compression fitting G ¾" A, ¾" NPT:

- Stainless steel, 1.4404 (316L)
- Hastelloy AC22, 2.4602 similar to N06022

Threadolet:

- Stainless steel, 1.4404 (316L)
- Hastelloy AC22, 2.4602 similar to N06022

Union nut for compression fitting and threadolet:

Stainless steel, 1.4571 similar to 316Ti

Clamping ferrules:



- PEEK 450G
- Stainless steel, 1.4404 (316L)
- Hastelloy AC22, 2.4602 (N06022)

Sealing ring EPDM/HNBR for G ¾" A:

Stainless steel, 1.4404 similar to 316L (outer ring)

Hygienic version

- 1-½" Tri-Clamp, 2" Tri-Clamp ISO 2852/DIN 32676:
 - Stainless steel, 1.4404 (316L)
- Conical coupling, DN40 DIN 11851, DN50 DIN 11851:
 - Stainless steel, 1.4404 (316L)
- Aseptic liner, DN40 DIN 11864-1A, DN50 DIN 11864-1A:
 - Stainless steel, 1.4404 (316L)
- Union nut DN40, DN50:
 - Stainless steel, 1.4301 similar to 304

 List of all available process connections (→  122)

Accessories

Mounting boss

Stainless steel, 1.4404 (316/316L)

Hot tap

- Process connection:
 - Weld-in nipple:
Stainless steel, 1.4404 (316/316L)
 - Flange/flange adapter:
Stainless steel, 1.4404 (316L)
- Sensor connection:
Stainless steel, 1.4404 (316/316L)
- Ball valve:
Stainless steel, CF3M, CF8M
Seal:
PTFE

Weather protection cover

Stainless steel 1.4301

Process connections

Standard version

Compression fitting:

- G 3/4 A, 3/4" NPT:
ISO 228/1
- Union nut and threadolet

Hygienic version

- Tri-Clamp:
ISO 2852/DIN 32676
- Conical coupling with union nut (sanitary connection):
DIN 11851
- Aseptic liner with union nut:
DIN 11864-1 Form A

 For information on the materials of the process connections (→  120)

16.11 Operability



Local operation

Order code for "Display; Operation", option C "SD02"

Display elements

- 4-line display
- Format for displaying measured variables and status variables can be individually configured
- Permitted ambient temperature for the display: -20 to +60 °C (-4 to +140 °F)
The readability of the display may be impaired at temperatures outside the temperature range.

Operating elements

- With order code for "Display; operation", option **C**:
Local operation with 3 push buttons: , , 
- Operating elements also accessible in various hazardous areas

Additional functionality

- Data backup function
The device configuration can be saved in the display module.
- Data comparison function
The device configuration saved in the display module can be compared to the current device configuration.
- Data transfer function
The transmitter configuration can be transmitted to another device using the display module.

Remote operation

HART protocol

Operation via:

- HART protocol
- Operating tools via FXA191, FXA195
 - FieldCare
 - AMS Device Manager
 - SIMATIC PDM
- HART handheld terminals
 - Field Communicator 475
 - Field Xpert SFX350
 - Field Xpert SFX370

Languages

Can be operated in the following languages:

- Via local display:
English, German, French, Spanish, Italian, Dutch, Portuguese, Polish, Russian, Turkish, Chinese, Japanese, Korean, Vietnamese, Czech, Swedish
- Via operating tools:
English, German, French, Spanish, Italian, Chinese, Japanese

16.12 Certificates and approvals

CE mark

The measuring system is in conformity with the statutory requirements of the applicable EC Directives. These are listed in the corresponding EC Declaration of Conformity along with the standards applied.

Endress+Hauser confirms successful testing of the device by affixing to it the CE mark.

C-Tick symbol



The measuring system meets the EMC requirements of the "Australian Communications and Media Authority (ACMA)".

Ex approval

The devices are certified for use in hazardous areas and the relevant safety instructions are provided in the separate "Safety Instructions" (XA) document. Reference is made to this document on the nameplate.

Hygienic compatibility



- 3A approval
- EHEDG-tested

 Overview of suitable process connections (→  122)

Other standards and guidelines

- EN 60529
Degrees of protection provided by enclosures (IP code)
- EN 61010-1
Safety requirements for electrical equipment for measurement, control and laboratory use
- IEC/EN 61326
Emission in accordance with Class A requirements. Electromagnetic compatibility (EMC requirements).
- NAMUR NE 32
Data retention in the event of a power failure in field and control instruments with microprocessors
- NAMUR NE 43
Standardization of the signal level for the breakdown information of digital transmitters with analog output signal.
- NAMUR NE 53
Software of field devices and signal-processing devices with digital electronics
- NAMUR NE 105
Specifications for integrating fieldbus devices in engineering tools for field devices
- NAMUR NE 107
Status classification as per NE107

16.13 Accessories

 Overview of accessories available for order (→  107)



16.14 Documentation

-  The following document types are available:
- On the CD-ROM supplied with the device
 - In the Download Area of the Endress+Hauser Internet site: www.endress.com → Download

Standard documentation

Communication	Document type	Documentation code
----	Brief Operating Instructions	KA01155D
----	Technical Information	TI01127D

Supplementary device-dependent documentation

Document type	Contents	Documentation code
Safety Instructions	ATEX/IECEX Ex nA	XA01237D
Installation Instructions		 Overview of accessories available for order: (→  107)

17 Appendix

17.1 Overview of the operating menu

The following table provides an overview of the entire operating menu structure with menus and parameters. The direct access code to the parameter is given in brackets. The page reference indicates where a description of the parameter can be found in the manual.

17.1.1 Main menu

Main menu	→	Language	(→ 55)
		Operation	(→ 125)
		Setup	(→ 125)
		Diagnostics	(→ 131)
		Expert	(→ 133)

17.1.2 "Operation" menu

Operation	→		
Language			(→ 55)
Access status display			(→ 47)
Locking status			(→ 80)
		Display	→ (→ 71)
		Format display	(→ 72)
		Contrast display	(→ 42)
		Display interval	(→ 73)
		Operation	→ (→ 86)
		Control Totalizer	(→ 86)
		Preset value	(→ 86)
		Reset all totalizers	(→ 86)





























17.1.3 "Setup" menu

Setup	→		(→ 56)
		Device tag	(→ 58)
		Temperature	(→ 57)

Pipe inner diameter		(→ 57)
Installation factor		(→ 57)
Assign status input		(→ 57)
Assign current output		(→ 57)
4 mA value		(→ 57)
20 mA value		(→ 57)
Operating mode		(→ 57)
Assign frequency output		(→ 57)
Measuring value at minimum frequency		(→ 57)
Measuring value at maximum frequency		(→ 57)
Switch output function		(→ 57)
Assign limit		(→ 57)
Switch-off value		(→ 57)
Switch-on value		(→ 58)
Assign status		(→ 58)
Assign diagnostic behavior		(→ 58)
Assign pulse output		(→ 58)
Value per pulse		(→ 58)
Advanced setup	→	(→ 59)
Enter access code		(→ 47)
System units	→	(→ 60)
Volume flow unit		(→ 60)
Volume unit		(→ 60)
Mass flow unit		(→ 60)
Mass unit		(→ 60)
Density unit		(→ 61)
Temperature unit		(→ 61)
Length unit		(→ 61)
Status input	→	(→ 69)
Assign status input		(→ 57)





























Active level	(→  70)
Response time status input	(→  70)
Current output 1 →	(→  61)
Assign current output	(→  57)
Mass flow unit	(→  60)
Volume flow unit	(→  60)
Temperature unit	(→  61)
Current span	(→  63)
4 mA value	(→  57)
20 mA value	(→  57)
20 mA value	(→  57)
4 mA value	(→  57)
Failure mode	(→  63)
Failure current	(→  63)
Pulse/frequency/switch output	(→  63)
Operating mode	(→  57)
Assign pulse output	(→  58)
Assign frequency output	(→  57)
Switch output function	(→  57)
Assign diagnostic behavior	(→  58)
Assign limit	(→  57)
Assign status	(→  58)
Mass flow unit	(→  60)
Mass unit	(→  60)
Volume flow unit	(→  60)
Volume unit	(→  60)
Unit totalizer	(→  69)
Temperature unit	(→  61)
Value per pulse	(→  58)
Pulse width	(→  64)

Failure mode		(→ 64)
Minimum frequency value		(→ 66)
Maximum frequency value		(→ 66)
Maximum frequency value		(→ 66)
Minimum frequency value		(→ 66)
Measuring value at minimum frequency		(→ 57)
Measuring value at maximum frequency		(→ 57)
Measuring value at maximum frequency		(→ 57)
Measuring value at minimum frequency		(→ 57)
Failure mode		(→ 66)
Failure frequency		(→ 66)
Switch-on value		(→ 58)
Switch-off value		(→ 57)
Switch-off value		(→ 57)
Switch-on value		(→ 58)
Switch-on delay		(→ 69)
Switch-off delay		(→ 69)
Failure mode		(→ 69)
Invert output signal		(→ 64)
Output conditioning	→	(→ 70)
Display damping		(→ 70)
Current output 1	→	
	Response time	(→ 70)
	Damping	(→ 70)
Pulse/frequency/switch output	→	
	Response time	(→ 70)
	Damping output	(→ 70)
Low flow cut off	→	(→ 70)

Assign process variable	(→  71)
On value low flow cutoff	(→  71)
Off value low flow cutoff	(→  71)
Totalizer →	(→  71)
Assign process variable	(→  71)
Unit totalizer	(→  69)
Failure mode	(→  71)
Display →	(→  71)
Format display	(→  72)
Value 1 display	(→  72)
0% bargraph value 1	(→  72)
100% bargraph value 1	(→  72)
Decimal places 1	(→  73)
Value 2 display	(→  73)
Decimal places 2	(→  73)
Value 3 display	(→  73)
0% bargraph value 3	(→  73)
100% bargraph value 3	(→  73)
Decimal places 3	(→  73)
Value 4 display	(→  73)
Decimal places 4	(→  73)
Language	(Verweisziel existiert nicht, aber @y.link.required=true)
Display interval	(→  73)
Display damping	(→  73)
Header	(→  73)
Header text	(→  73)
Separator	(→  73)
Configuration backup display →	(→  77)
Operating time	(→  78)

Last backup	(→ 78)
Configuration management	(→ 78)
Comparison result	(→ 78)
Administration →	(→ 80)
Define access code →	(→ 80)
Define access code	(→ 80)
Confirm access code	(→ 80)
Device reset	(→ 102)

17.1.4 "Diagnostics" menu

Diagnostics →	(→  89)
Actual diagnostics	(→  100)
Previous diagnostics	(→  100)
Operating time from restart	(→  100)
Operating time	(→  100)
Diagnostic list →	(→  100)
Diagnostics 1 to 5	(→  100)
Event logbook →	(→  100)
Filter options	(→  100)
Device information →	(→  102)
Device tag	(→  103)
Serial number	(→  103)
Firmware version	(→  103)
Device name	(→  103)
Order code	(→  103)
Extended order code 1 to 3	(→  103)
ENP version	(→  103)
Measured values →	(→  84)
Process variables →	(→  84)
Volume flow	(→  84)
Mass flow	(→  84)
Temperature	(→  57)
Totalizer →	(→  84)
Totalizer value	(→  85)
Totalizer overflow	(→  85)
Input values →	(→  85)
Value status input	(→  85)
Output values →	(→  85)
Output current	(→  86)

	Pulse output	(→ 86)
	Output frequency	(→ 86)
	Switch status	(→ 86)
	Data logging ¹⁾ →	(→ 87)
	Assign channel 1 to 4	(→ 88)
	Logging interval	(→ 88)
	Clear logging data	(→ 88)
	Simulation →	(→ 78)
	Assign simulation process variable	(→ 79)
	Value process variable	(→ 79)
	Simulation status input	(→ 79)
	Input signal level	(→ 79)
	Simulation current output	(→ 79)
	Value current output	(→ 79)
	Frequency simulation	(→ 79)
	Frequency value	(→ 79)
	Pulse simulation	(→ 80)
	Pulse value	(→ 80)
	Switch output simulation	(→ 80)
	Switch status	(→ 80)
	Simulation device alarm	(→ 80)
	Diagnostic event category	(→ 80)
	Simulation diagnostic event	(→ 80)

1) Order characteristic "Application package", option EA "Extended HistoROM", see Technical Information for device, "Application packages" section

















17.1.5 "Expert" menu

Overview "Expert" menu

Expert	→	(→ ⓘ 35)
Direct access (0106)		(→ ⓘ 44)
Locking status (0004)		(→ ⓘ 47)
Access status display (0091)		(→ ⓘ 47)
Enter access code (0092)		(→ ⓘ 47)
System		(→ ⓘ 133)
Sensor		(→ ⓘ 135)
Input		(→ ⓘ 137)
Output		(→ ⓘ 137)
Communication		(→ ⓘ 139)
Application		(→ ⓘ 140)
Diagnostics		(→ ⓘ 140)

"System" submenu

















System	→	
Display	→	(→ ⓘ 71)
Language (0104)		(→ ⓘ 72)
Format display (0098)		(→ ⓘ 72)
Value 1 display (0107)		(→ ⓘ 72)
0% bargraph value 1 (0123)		(→ ⓘ 72)
100% bargraph value 1 (0125)		(→ ⓘ 73)
Decimal places 1 (0095)		(→ ⓘ 73)
Value 2 display (0108)		(→ ⓘ 73)
Decimal places 2 (0117)		(→ ⓘ 73)
Value 3 display (0110)		(→ ⓘ 73)
0% bargraph value 3 (0124)		(→ ⓘ 73)
100% bargraph value 3 (0126)		(→ ⓘ 73)











Decimal places 3 (0118)		(→  73)
Value 4 display (0109)		(→  73)
Decimal places 4 (0119)		(Verweiszie l existiert nicht, aber @y.link.req uired='true')
Display interval (0096)		(→  73)
Display damping (0094)		(→  73)
Header (0097)		(→  73)
Header text (0112)		(→  73)
Separator (0101)		(→  73)
Contrast display (0105)		(→  42)
Access status display (0091)		(→  47)
Configuration backup display	→	(→  77)
Operating time (0652)		(→  78)
Last backup (0102)		(→  78)
Configuration management (0100)		(→  78)
Comparison result (0103)		(→  78)
Diagnostic handling	→	
Alarm delay (0651)		(→  92)
	Diagnostic behavior	→ (→  96)
	Assign behavior of diagnostic no. 441 (0657)	
	Assign behavior of diagnostic no. 442 (0658)	
	Assign behavior of diagnostic no. 443 (0659)	
	Assign behavior of diagnostic no. 832 (0675)	
	Assign behavior of diagnostic no. 833 (0676)	

	Assign behavior of diagnostic no. 834 (0677)	
	Assign behavior of diagnostic no. 835 (0678)	
	Assign behavior of diagnostic no. 862	
Administration →		(→ 80)
	Define access code →	(→ 80)
	Define access code	(→ 80)
	Confirm access code	(→ 80)
	Device reset (0000)	(→ 102)
	Activate SW option (0029)	
	Software option overview (0015)	
	Reset write protection (0019)	





"Sensor" submenu

Sensor →		
Measured values →		(→ 84)
	Process variables →	(→ 84)
	Volume flow (1838)	(→ 84)
	Mass flow (1847)	(→ 84)
	Temperature (1851)	(→ 57)
	Totalizer →	(→ 84)
	Totalizer value (0911)	(→ 85)
	Totalizer overflow (0910)	(→ 85)
	Input values →	(→ 85)
	Value status input	(→ 85)
	Output values →	(→ 85)
	Output current (0361)	(→ 86)
	Pulse output (0456)	(→ 86)
	Output frequency (0471)	(→ 86)







		Switch status (0461)	(→  86)
System units	→		(→  60)
		Volume flow unit (0553)	(→  60)
		Volume unit (0563)	(→  60)
		Mass flow unit (0554)	(→  60)
		Mass unit (0574)	(→  60)
		Density unit (0555)	(→  61)
		Temperature unit (0557)	(→  61)
		Length unit (0551)	(→  61)
	User-specific units	→	
		User volume text (0567)	
		User volume offset (0569)	
		User volume factor (0568)	
		User mass text (0560)	
		User mass offset (0562)	
		User mass factor (0561)	
Process parameters	→		
		Flow override (1839)	
		Flow damping (1802)	
	Low flow cut off	→	(→  70)
		Assign process variable (1837)	(→  71)
		On value low flow cutoff (1805)	(→  71)
		Off value low flow cutoff (1804)	(→  71)
Sensor adjustment	→		
	Installation settings	→	
		Installation factor	
		Pipe wall thickness	
		Mounting set height	
		Insertion depth	
	In-situ adjustment	→	(→  74)
		Operating mode	(→  75)
		Adjustment values in use	(→  75)
		Flow reference in use	(→  75)

























	Flow reference value 1 to 8	(→  75)
	Power coefficient 1 to 8	(→  75)
	New adjustment →	(→  75)
	Select flow reference	(→  76)
	Perform adjustment →	(→  76)
	Clear values	(→  77)
	Flow reference value 1 to 8	(→  77)
	Power coefficient 1 to 8	(→  77)
	Use adjustment →	(→  77)
	Data validity	(→  77)
	Apply	(→  77)
Calibration →	Calibration date/time	

"Input" submenu

Input →	Status input →	(→  85)
	Assign status input	(→  57)
	Value status input	(→  85)
	Active level	(→  70)
	Response time status input	(→  70)

"Output" submenu

Output →	Current output →	(→  61)
	Assign current output (0359)	(→  57)
	Current span (0353)	(→  63)
	Fixed current (0365)	
	4 mA value (0367)	(→  57)
	20 mA value (0372)	(→  57)
	Damping (0363)	(→  70)
	Response time (0378)	(→  70)

Failure mode (0364)		(→  63)
Failure current (0352)		(→  63)
Output current (0361)		(→  86)
Start-up mode (0368)		
Start-up current (0369)		
Pulse/frequency/switch output	→	(→  63)
Operating mode (0469)		(→  57)
Assign pulse output (0460)		(→  58)
Value per pulse (0455)		(→  58)
Pulse width (0452)		(→  64)
Failure mode (0480)		(→  64)
Pulse output (0456)		(→  86)
Assign frequency output (0478)		(→  57)
Minimum frequency value (0453)		(→  66)
Maximum frequency value (0454)		(→  66)
Measuring value at minimum frequency (0476)		(→  57)
Measuring value at maximum frequency (0475)		(→  57)
Damping		(→  70)
Response time (0491)		(→  70)
Failure mode (0451)		(→  66)
Failure frequency (0474)		(→  66)
Output frequency (0471)		(→  86)
Switch output function (0481)		(→  57)
Assign diagnostic behavior (0482)		(→  58)
Assign limit (0483)		(→  57)
Switch-on value (0466)		(→  58)
Switch-off value (0464)		(→  57)

Assign status (0485)	(→ ⓘ 58)
Switch-on delay (0467)	(→ ⓘ 69)
Switch-off delay (0465)	(→ ⓘ 69)
Failure mode (0486)	(→ ⓘ 69)
Switch status (0461)	(→ ⓘ 86)
Invert output signal (0470)	(→ ⓘ 64)

"Communication" submenu

Communication →		
	HART output →	(→ ⓘ 53)
	Configuration →	
	Burst mode (0208)	(→ ⓘ 54)
	Burst command (0207)	
	HART short tag	
	Device tag	
	HART address (0219)	
	No. of preambles (0217)	
	Information →	(→ ⓘ 102)
	Device revision (0204)	(Verweisziel existiert nicht, aber @y.link.required=true)
	Device ID (0221)	(Verweisziel existiert nicht, aber @y.link.required=true)
	Device type (0222)	(Verweisziel existiert nicht, aber @y.link.required=true)
	Manufacturer ID (0223)	(Verweisziel existiert nicht, aber @y.link.required=true)



















HART revision (0205)	(→ 53)
HART descriptor (0212)	
HART message (0216)	
Hardware revision (0206)	
Software revision (0224)	
HART date code (0202)	
Output →	(→ 53)
Assign PV (0234)	(→ 53)
Primary variable (PV) (0201)	(→ 53)
Assign SV (0235)	(→ 53)
Secondary variable (SV) (0226)	(→ 53)
Assign TV (0236)	(→ 53)
Tertiary variable (TV) (0228)	(→ 53)
Assign QV (0237)	(→ 53)
Quaternary variable (QV) (0203)	(→ 53)

"Application" submenu

Application →	Totalizer →	(→ 71)
	Assign process variable (0914)	(→ 71)
	Unit totalizer (0915)	(→ 69)
	Control Totalizer (0912)	(→ 86)
	Preset value (0913)	(→ 86)
	Failure mode (0901)	(→ 71)
	CIP/SIP →	
	CIP/SIP mode	

"Diagnostics" submenu

Diagnostics →	(→ 89)
----------------------	--------

Actual diagnostics (0691)		(→  100)
Previous diagnostics (0690)		(→  100)
Operating time from restart (0653)		(→  100)
Operating time (0652)		(→  100)
	Diagnostic list →	(→  100)
	Diagnostics 1 to 5 (0692-1 to 5)	(→  100)
	Event logbook →	(→  100)
	Filter options (0705)	(Verweissel existiert nicht, aber @y.link.required=true)
	Device information →	(→  102)
	Device tag (0011)	(→  103)
	Serial number (0009)	(→  103)
	Firmware version (0010)	(→  103)
	Device name (0013)	(→  103)
	Order code (0008)	(→  103)
	Extended order code 1 to 3 (0023-1 to 3)	(→  103)
	ENP version (0012)	(→  103)
	Configuration counter	
	Data logging ¹⁾ →	(→  87)
	Assign channel 1 to 4 (0851-1 to 4)	(→  88)
	Logging interval (0856)	(→  88)
	Clear logging data (0855)	(→  88)
	Min/max values →	
	Electronic temperature →	
	Minimum value	
	Maximum value	
	Process temperature →	

	Minimum value	
	Maximum value	
Simulation	→	(→ ⓘ 78)
Assign simulation process variable (1810)		(→ ⓘ 79)
Value process variable (1811)		(→ ⓘ 79)
Simulation status input		(→ ⓘ 79)
Input signal level		(→ ⓘ 79)
Simulation current output 1 (0354)		(→ ⓘ 79)
Value current output 1 (0355)		(→ ⓘ 79)
Frequency simulation (0472)		(→ ⓘ 79)
Frequency value (0473)		(→ ⓘ 79)
Pulse simulation (0458)		(→ ⓘ 80)
Pulse value (0459)		(→ ⓘ 80)
Switch output simulation (0462)		(→ ⓘ 80)
Switch status (0463)		(→ ⓘ 80)
Simulation device alarm (0654)		(→ ⓘ 80)
Diagnostic event category (0738)		(→ ⓘ 80)
Simulation diagnostic event (0737)		(→ ⓘ 80)

1) Order characteristic "Application package", option EA "Extended HistorOM", see Technical Information for device, "Application packages" section

Index

A

- Access authorization to parameters
 - Read access 47
 - Write access 47
- Access code 47
 - Incorrect input 47
- Adapting the diagnostic behavior 96
- Ambient temperature range 24
- AMS Device Manager 51
 - Function 51
- Application 9, 110
- Applicator 110, 110
- Approvals 123

C

- C-Tick symbol 123
- Cable entries
 - Technical data 115
- Cable entry
 - Degree of protection 31
- CE mark 123
- CE mark (declaration of conformity) 10
- Certificates 123
- Checklist
 - Post-connection check 31
 - Post-installation check 27
- Cleaning
 - Cleaning the transducer 104
 - Exterior cleaning 104
 - Interior cleaning 104
- Commissioning 55
 - Advanced settings 59
 - Configuring the measuring device 56
- Communication-specific data 53
- Connecting cable 28
- Connecting the measuring device 30
- Connection
 - see Electrical connection
- Connection preparations 29
- Connection tools 28
- Context menu
 - Calling up 43
 - Closing 43
 - Explanation 43
- Current consumption 114

D

- Declaration of Conformity 10
- Define access code 80, 80
- Degree of protection 31, 117
- Designated use 9
- Device components 12
- Device description files 53, 53
- Device documentation
 - Supplementary documentation 8
- Device locking, status 83

- Device name
 - Sensor 15
 - Transmitter 14
- Device repair 105
- Device revision 53
- Device type ID 53
- Diagnostic behavior
 - Explanation 92
 - Symbols 92
- Diagnostic information 93
 - In the operating tool 94
 - Local display 91
 - Overview 97
 - Remedial measures 97
- Diagnostic list 100
- Diagnostic message 91
- Diagnostics
 - Symbols 91
- Dimensions 24
- DIP switch
 - see Write protection switch
- Direct access 44
- Direct access code 39
- Disabling write protection 80
- Display
 - Current diagnostic event 99
 - Previous diagnostic event 99
 - see Local display
- Display area
 - For operational display 37
 - In the navigation view 39
- Display values
 - For locking status 83
- Disposal 105
- Document
 - Function 6
 - Symbols used 6
- Document function 6

E

- Electrical connection
 - Commubox FXA195 49
 - Commubox FXA291 50
 - Degree of protection 31
 - Field Communicator 49
 - Handheld terminals 49
 - Measuring device 28
 - Operating tools 49
 - Via HART protocol 49
 - Via service interface (CDI) 50
- Electromagnetic compatibility 117
- Electronics board
 - I/O electronics modules 30
- Electronics housing
 - Turning
 - see Turning the transmitter housing

- Electronics module 12
- Electronics modules 30
- Enabling write protection 80
- Endress+Hauser services
 - Maintenance 104
 - Repair 105
- Error messages
 - see Diagnostic messages
- Event history 100
- Events list 100
- Ex approval 123
- Ex connection data 113
- Extended order code
 - Sensor 15
 - Transmitter 14
- Exterior cleaning 104
- F**
 - Field Communicator
 - Function 52
 - Field Communicator 475 52
 - Field of application
 - Residual risks 10
 - Field Xpert 50
 - Function 50
 - FieldCare 50
 - Function 50
 - User interface 51
 - Filtering the event logbook 101
 - Firmware
 - Release date 53
 - Version 53
 - Firmware history 103
 - Flow direction 18, 25
 - Flow limit 118
 - Function check 55
 - Function scope
 - AMS Device Manager 51
 - Field Communicator 52
 - Field Communicator 475 52
 - Field Xpert 50
 - FieldCare 50
 - SIMATIC PDM 51
- Functions
 - see Parameter
- G**
 - Galvanic isolation 113
- H**
 - Hardware write protection 81
 - HART protocol 123
 - Device variables 53
 - Measured variables 53
 - Revision 53
 - Help text
 - Calling up 45
 - Closing 45
 - Explanation 45
- HistoROM 77
- Hygienic compatibility 123
- I**
 - Identifying the measuring device 14
 - Incoming acceptance 13
 - Influence
 - Medium temperature 116
 - Information on the document 6
 - Inlet runs 23
 - Input 110
 - Input mask 41
 - Inspection check
 - Connection 31
 - Installation 27
 - Received goods 13
 - Installation 18
 - Installation conditions
 - Dimensions 24
 - Inlet and outlet runs 23
 - Mounting location 18
 - Orientation 18
 - System pressure 24, 118
 - Thermal insulation 24, 118
 - Interior cleaning 104
- K**
 - Keypad lock
 - Disabling 47
 - Enabling 47
- L**
 - Languages, local operation 123
 - Line recorder 87
 - Load 29
 - Local display 122
 - Editing view 40
 - Navigation view 38
 - see Diagnostic message
 - see In alarm condition
 - see Operational display
 - Local operation
 - Languages 123
 - Low flow cut off 113
- M**
 - Main electronics module 12
 - Maintenance 104
 - Maintenance tasks 104
 - Managing the device configuration 77
 - Manufacturer ID 53
 - Manufacturing date 14, 15
 - Materials 120
 - Maximum measured error 115
 - Measured variables
 - Calculated 110
 - Direct 110
 - see Process variables
 - Measuring and test equipment 104
 - Measuring device

- Configuration 56
 - Conversion 105
 - Disposal 106
 - Integrating via HART protocol 53
 - Mounting the sensor 25
 - Preparing for electrical connection 29
 - Preparing for mounting 25
 - Removing 105
 - Repair 105
 - Structure 12
 - Switch-on 55
 - Measuring principle 110
 - Measuring range 110
 - Calibrated 110
 - Measuring range, recommended 118
 - Measuring system 110
 - Media 9
 - Medium temperature
 - Influence 116
 - menu
 - Diagnostics 99
 - Operation 83
 - Setup 56, 58
 - Menus
 - For measuring device configuration 56
 - For specific settings 59
 - Mounting dimensions
 - see Dimensions
 - Mounting location 18
 - Mounting preparations 25
 - Mounting tools 25
- N**
- Nameplate
 - Sensor 15
 - Additional 15
 - Transmitter 14
 - Navigation path (navigation view) 39
 - Navigation view
 - In the submenu 38
 - In the wizard 38
 - Numeric editor 40
- O**
- Operable flow range 111
 - Operating elements 42, 93
 - Operating keys
 - see Operating elements
 - Operating menu
 - Menus, submenus 33
 - Overview of menus with parameters 125
 - Structure 33
 - Submenus and user roles 35
 - Wizards 33
 - Operating philosophy 35
 - Operation 83
 - Operation options 33, 33
 - Operational display 36
 - Operational safety 10
- Order code 14, 14, 15
 - Orientation (vertical, horizontal) 18
 - Outlet runs 23
 - Output 112
 - Output signal 112
 - Overview
 - Operating menu 125
- P**
- Packaging disposal 17
 - Parameter
 - Changing 46
 - Enter a value 46
 - Parameter settings
 - Adjustment values in use (submenu) 75
 - Configuration (submenu) 54
 - Configuration backup display (submenu) 77
 - Current output 1 (wizard) 61
 - Data logging (submenu) 87
 - Device information (submenu) 102
 - Diagnostic behavior (submenu) 73
 - Diagnostics (menu) 99
 - Display (submenu) 71, 83
 - For the status input 69
 - In-situ adjustment (submenu) 74
 - Input values (submenu) 85
 - Low flow cut off (submenu) 70
 - New adjustment (submenu) 75
 - Operation (submenu) 86
 - Output conditioning (submenu) 70
 - Output values (submenu) 85
 - Perform adjustment (submenu) 76
 - Process variables (submenu) 84
 - Pulse/frequency/switch output (wizard) 63, 65, 66
 - Setup (menu) 56, 58
 - Simulation (submenu) 78
 - Status input (submenu) 69
 - System units (submenu) 60
 - Totalizer (submenu) 84
 - Totalizer 1 (submenu) 71
 - Use adjustment (submenu) 77
 - Performance characteristics 115
 - Post-connection check (checklist) 31
 - Post-installation check 55
 - Post-installation check (checklist) 27
 - Power supply failure 115
 - Pressure loss 118
 - Pressure-temperature ratings 117
 - Process connections 122
 - Product safety 10
 - Protecting parameter settings 80
- R**
- Read access 47
 - Reading measured values 84
 - Recalibration 104
 - Reference operating conditions 115
 - Registered trademarks 8
 - Remedial measures

- Calling up 94, 96
- Closing 94, 96
- Remote operation 123
- Repair 105
 - Notes 105
- Repair of a device 105
- Repeatability 116
- Replacement
 - Device components 105
- Requirements for personnel 9
- Response time 116
- Returning devices 105
- S**
- Safety
 - Safety instructions 9
- Seals
 - Fluid temperature range 117
- Sensor
 - Fluid temperature range 117
 - Mounting 25
- Serial number 14, 15
- Setting the operating language 55
- Settings
 - Adapting the measuring device to the process conditions 86
 - Advanced display configurations 71
 - Current output 61
 - Device reset 102
 - Device tag 58
 - In-situ adjustment 74
 - Low flow cut off 70
 - Managing the device configuration 77
 - New adjustment 75
 - Operating language 55
 - Output conditioning 70
 - Perform adjustment 76
 - Pulse/frequency/switch output 63
 - Resetting the totalizer 86
 - Simulation 78
 - Status input 69
 - System units 60
 - Totalizer 71
 - Totalizer reset 86
 - Use adjustment 77
 - Values in use 75
- Shock resistance 117
- Showing data logging 87
- Signal on alarm 112
- SIMATIC PDM 51
 - Function 51
- Software release 53
- Spare part 105
- Spare parts 105
- Standards and guidelines 124
- Status area
 - For operational display 37
 - In the navigation view 39
- Status signals 91
- Storage conditions 17
- Storage temperature 17
- Structure
 - Measuring device 12
- Structure of the operating menu 33
- submenu
 - Adjustment values in use 75
 - Advanced setup 59
 - Configuration 54
 - Configuration backup display 77
 - Data logging 87
 - Device information 102
 - Diagnostic behavior 73
 - Display 71, 83
 - In-situ adjustment 74
 - Input values 85
 - Low flow cut off 70
 - New adjustment 75
 - Operation 86
 - Output conditioning 70
 - Output values 85
 - Perform adjustment 76
 - Process variables 84
 - Simulation 78
 - Status input 69
 - System units 60
 - Totalizer 84
 - Totalizer 1 71
 - Use adjustment 77
- Submenu
 - Define access code 80
 - Events list 100
 - Input values 85
 - Output values 85
 - Overview 35
 - Process variables 84
 - Totalizer 84
- Supply unit
 - Requirements 29
- Supply voltage 29, 114
- Symbols
 - For communication 37
 - For correction 41
 - For diagnostic behavior 37
 - For locking 37
 - For measured variable 37
 - For measurement channel number 37
 - For menus 39
 - For parameters 39
 - For status signal 37
 - For submenu 39
 - For wizard 39
 - In the status area of the local display 37
 - In the text and numeric editor 41
- System design
 - Measuring system 110
 - see Measuring device design
- System integration 53
- System pressure 24, 118

T

Technical data, overview	110
Temperature range	
Ambient temperature	24
Ambient temperature range for display	122
Medium temperature	117
Storage temperature	17
Terminal assignment	28, 30
Terminal voltage	29
Terminals	115
Text editor	40
Thermal insulation	24, 118
Tool tip	
see Help text	
Tools	
For electrical connection	28
For mounting	25
Transport	17
Transmitter	
Connecting the signal cables	30
Turning the display module	27
Turning the housing	26
Transmitter housing	
Turning	26
Transporting the measuring device	17
Troubleshooting	
General	89
Turning the display module	27

U

Use of the measuring device	
see Designated use	
Use of the measuring devices	
Borderline cases	9
Incorrect use	9
User interface	
FieldCare	51
User roles	35

V

Version data for the device	53
Vibration resistance	117

W

W@M	104, 105
W@M Device Viewer	14, 105
Weight	
Compact version	119
Transport (notes)	17
wizard	
Current output 1	61
Define access code	80
Pulse/frequency/switch output	63, 65, 66
Workplace safety	10
Write access	47
Write protection	
Via access code	80
Via write protection switch	81
Write protection switch	81

www.addresses.endress.com
