



Level



Pressure



Flow



Temperature



Liquid  
Analysis



Registration



Systems  
Components



Services



Solutions

## Operating Instructions

# Silopilot T FMM20

## Electromechanical Level System

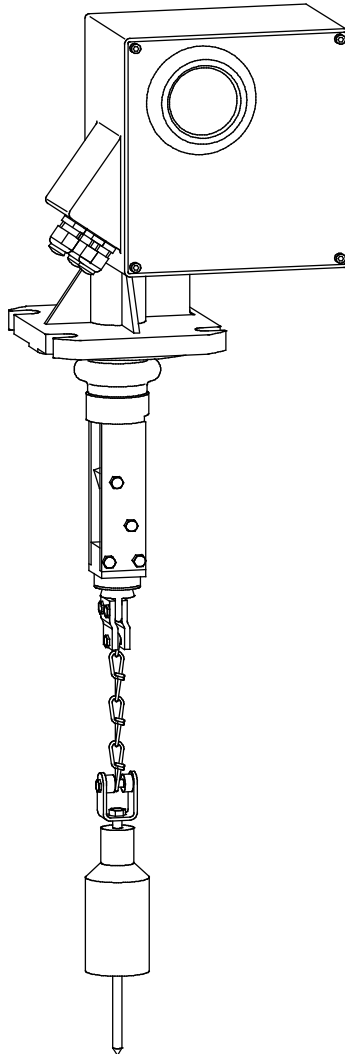

## Brief overview

For easy and fast commissioning:

<b>Safety instructions</b>	
Explanation of warning symbols Special information can be found at the corresponding point in the relevant chapter. You can see the significance from the Warning ⚠, Attention ⚡ and Note 📌 symbols.	→ Page 4 ff.
▼	
<b>Installation</b>	
The handling steps for installing the device and the installation conditions (e.g. dimensions) can be found here.	→ Page 12 ff.
▼	
<b>Wiring</b>	
In this chapter, you can learn all about the device's electrical connections (incl. precise assignment of terminals).	→ Page 18 ff.
▼	
<b>Operation</b>	
Here you will find an overview of the positions of the device's display and operating elements.	→ Page 22 ff.
▼	
<b>Commissioning</b>	
Successful initial start-up is explained in this chapter.	→ Page 26 ff.
▼	
<b>Description of device functions</b>	
All the device functions are explained in this chapter.	→ Page 29 ff.
▼	
<b>Troubleshooting</b>	
If faults arise during operation, you can determine the causes here. Actions with which the faults can be remedied are also explained.	→ Page 46 ff.
▼	
<b>Index</b>	
Important terms and key words for the individual chapters can be found here. Use the index to find information in a quick and targeted manner.	→ Page 71

## Table of contents

<b>1</b>	<b>Safety instructions .....</b>	<b>4</b>	<b>9</b>	<b>Manual mode .....</b>	<b>44</b>
1.1	Intended use .....	4	9.1	Operation.....	44
1.2	Installation, commissioning, operation .....	4	9.2	Display.....	45
1.3	Safety instructions (ATEX) .....	4	<b>10</b>	<b>Troubleshooting .....</b>	<b>46</b>
1.4	Notes on safety conventions and icons .....	6	10.1	Error messages .....	46
<b>2</b>	<b>Identification .....</b>	<b>7</b>	10.2	Types of error .....	46
2.1	Product structure .....	7	10.3	Error messages .....	47
2.2	Scope of delivery .....	8	<b>11</b>	<b>Maintenance.....</b>	<b>49</b>
2.3	Nameplate .....	9	11.1	External cleaning .....	49
2.4	Certificates and approvals .....	9	11.2	Cleaning dirty compartment.....	49
<b>3</b>	<b>Sensing weights.....</b>	<b>10</b>	11.3	Wiper check.....	49
3.1	Variants.....	10	11.4	Inspection of measuring tape .....	50
3.2	Selection recommendation .....	11	11.5	Dirty compartment check.....	50
<b>4</b>	<b>Installation.....</b>	<b>12</b>	<b>12</b>	<b>Repair.....</b>	<b>51</b>
4.1	Planning the installation location .....	12	12.1	Repairing Ex-certified devices.....	51
4.2	Installation conditions .....	13	12.2	Replacing components.....	51
4.3	Installation preparation.....	15	12.3	Returns .....	54
4.4	Installation .....	16	12.4	Spare parts .....	55
4.5	Incoming acceptance and storage.....	17	<b>13</b>	<b>Accessories.....</b>	<b>60</b>
4.6	Post-installation check.....	17	13.1	Protective hood.....	60
<b>5</b>	<b>Wiring.....</b>	<b>18</b>	<b>14</b>	<b>Technical data .....</b>	<b>61</b>
5.1	Electrical connection .....	18	14.1	Input values .....	61
5.2	Potential matching .....	18	14.2	Output values .....	61
5.3	Terminal assignment.....	19	14.3	Accuracy.....	62
5.4	Post-connection check .....	21	14.4	Min. time for one measurement cycle.....	62
<b>6</b>	<b>Operation .....</b>	<b>22</b>	14.5	Run-off speed.....	62
6.1	Quick operation guide .....	22	14.6	Power supply .....	62
6.2	Display and operating elements .....	23	14.7	Environmental conditions.....	63
6.3	General structure of operating menu.....	24	14.8	Process conditions.....	63
6.4	Identification of functions .....	25	<b>15</b>	<b>Appendix.....</b>	<b>64</b>
6.5	Blocking/releasing operation .....	25	15.1	Basic settings.....	64
<b>7</b>	<b>Commissioning.....</b>	<b>26</b>	15.2	Measurement parameter settings .....	64
7.1	Switching on measuring device.....	26	15.3	Output settings .....	64
7.2	Basic setup.....	27	15.4	Input settings .....	65
<b>8</b>	<b>Description of device functions .....</b>	<b>29</b>	15.5	Safety settings .....	65
8.1	"basic setup (00)" function group .....	29	15.6	Display settings .....	65
8.2	"inputs and outputs (01)" function group .....	31	15.7	Other settings .....	65
8.3	"measurement parameters (02)" function group .....	33	15.8	Operating menu .....	67
8.4	"current output (03)" function group.....	37	15.9	Software history .....	68
8.5	"safety settings (04)" function group.....	38	15.10	Declaration of contamination.....	69
8.6	"linearization (05)" function group.....	40			
8.7	"display (06)" function group .....	41			
8.8	"diagnostics (07)" function group .....	42			
8.9	"system parameters (08)" function group.....	43			

# 1 Safety instructions

## 1.1 Intended use

The Silopilot T FMM20 is a compact electromechanical level system. It is used for cyclical level measurements in bunkers or silos.

## 1.2 Installation, commissioning, operation

The Silopilot T FMM20 is a reliable state-of-the-art construction and complies with the relevant specifications and EC directives. However, if it is used incorrectly or not as intended, the devices may cause application-related hazardous situations, e.g. product overflow as a result of incorrect installation or setting.

Installation, electrical connection, commissioning, operation and maintenance of the measuring equipment must, therefore, only be undertaken by trained specialists who have been authorized for this purpose by the plant operator. The specialist must have read and understood these Operating Instructions and follow the instructions they contain.

Changes and repairs may only be undertaken on the device if the Operating Instructions expressly permit them.

## 1.3 Safety instructions (ATEX)

If the measuring system is used in explosion hazard zones, the corresponding national standards must be observed. The installation specifications, connection values and safety instructions contained in these Operating Instructions must be observed.

Please observe the following safety instructions:

- Ensure that specialists are sufficiently trained.
- The technical measurement and safety requirements of the measuring points must be observed.
- The Silopilot may only be operated when the housing is closed.
- The housing may only be opened when the supply voltage is switched off.
- The Silopilot version certified by ATEX must only be repaired by the manufacturer.
- If using the Silopilot in areas containing flammable dusts, the corresponding national standards must be observed.
- The requirements laid down in EN 50281-1-2, for example relating to dust deposits and temperatures, must be observed.
- Cable and line entries as well as dummy plugs must only be replaced with those of the same type.
- The operator must ensure that product cone discharges do not occur.

### 1.3.1 Features of the ATEX version

- Identification:  II 1/2D IP67 T99°C
- Certificate number: **BVS 05 ATEX E 049**

### 1.3.2 Installation instructions

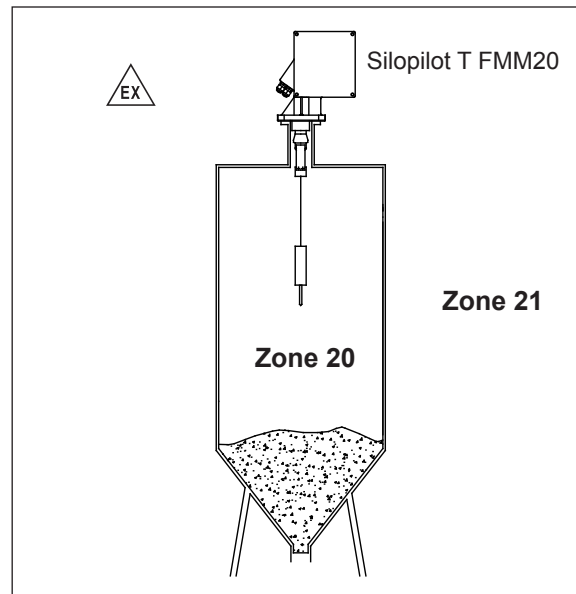







*Installation instructions (ATEX)*





For details refer to XA425F-A/97/a3.

## 1.4 Notes on safety conventions and icons

In order to highlight safety-related or alternative processes, we have laid down the following safety instructions where each piece of information is identified by a corresponding pictogram.

Symbol	Meaning
	<b>Warning!</b> Warning indicates activities or processes which lead to serious injuries to persons, to a safety hazard or to destruction of the device if they are not carried out properly.
	<b>Attention!</b> Attention indicates activities or processes which lead to injuries to persons or to incorrect operation of the device if they are not carried out properly.
	<b>Note!</b> Note indicates activities or processes which have an indirect influence on operation or can trigger an unforeseen device reaction if they are not carried out properly.

	<b>Explosion-protected, type-examined devices</b> If this symbol is shown on the nameplate of the device, the device can be used in hazardous areas or in non-hazardous areas according to the approval.
	<b>Hazardous area</b> This symbol indicates a hazardous area in the drawings of these Operating Instructions. - Devices located in hazardous areas or cables for such devices must have a corresponding explosion protection.
	<b>Safe area (non-hazardous area)</b> This symbol indicates a non-hazardous area in the drawings of these Operating Instructions. - Devices in non-hazardous areas must also be certified if connecting cables run into the hazardous area.

	<b>Direct current</b> A terminal at which there is DC voltage or through which direct current flows.
	<b>Alternating current</b> A terminal at which there is (sine-wave) alternating voltage or through which alternating current flows.
	<b>Ground connection</b> A grounded terminal which from the viewpoint of the user is already grounded via a grounding system.
	<b>Protective earth connection</b> A terminal which has to be grounded before other connections can be established.
	<b>Equipotential connection</b> A coupling that has to be connected to the grounding system of the plant. This can be, for example, a potential matching line or a star grounding system, depending on the national or company codes of practice.

## 2 Identification

### 2.1 Product structure

#### 2.1.1 Ordering information for the Silopilot T FMM20







<b>10</b>	<b>Approval:</b>			
	A	Non-hazardous area		
	B	ATEX II 1/2D IP67 T99°C		
	Y	Special version, to be specified		
<b>20</b>	<b>Housing:</b>			
	1	Aluminum		
	2	Aluminum, coated		
	9	Special version, to be specified		
<b>30</b>	<b>Measurement range; version:</b>			
	4	15 m; stainless steel tape (301, modified)		
	5	32 m; stainless steel tape (301, modified)		
	9	Special version, to be specified		
<b>40</b>	<b>Maximum connection height; wiper:</b>			
	A	230 mm, aluminum/steel		
	B	230 mm, stainless steel (304)		
	C	500 mm, aluminum/steel		
	D	500 mm, stainless steel (304)		
	E	1000 mm, aluminum/steel		
	F	1000 mm, stainless steel (304)		
	Y	Special version, to be specified		
<b>50</b>	<b>Power supply:</b>			
	1	90 - 253 VAC, 50/60 Hz		
	3	20 - 28 VDC		
	9	Special version, to be specified		
<b>60</b>	<b>Output:</b>			
	A	0/4 - 20 mA + 2x relay, adjustable		
	C	0/4 - 20 mA + 4x relay, adjustable		
		Relay function: counting pulse, reset pulse, maintenance, run-up, upper limit position, alarm or measurement active		
	Y	Special version, to be specified		
<b>70</b>	<b>Ambient temperature:</b>			
	D	Range -20 ... +60°C		
	E	Range -40 ... +60°C + heating (ATEX II 1/2D min. -35°C)		
	F	Range -20 ... +60°C + extended climate resistance		
	Y	Special version, to be specified		





## 2.3 Nameplate

You will find the following technical data on the device's nameplate:

<b>Endress+Hauser</b> 	Order number
<b>Silopilot T FMM20</b>	Serial number
Order Code: B11A1AE1A1	
Ser. No: 1000 - 2006	
 90-253VAC	Supply voltage
170VA      Contact rating max!	
50/60Hz        /        250VAC	Communication variant
 0/4-20mA      6A	
 II 1/2 D IP67 T99°C	Identification in accordance with Directive 94/9/EC and identification of type of explosion protection
BVS 05 ATEX E 049	
-35°C < Tamb < +60°C	
  BA334F/97	Reference to additional (safety-relevant) documentation
 0032	
Made In Germany D-79689 Maulburg	

Information of the nameplate

## 2.4 Certificates and approvals

### 2.4.1 CE mark, declaration of conformity

The device is built and tested in a reliable, state-of-the-art design and left the factory in perfect condition. The device complies with the relevant standards and specifications as defined in EN 61010 "Safety requirements for electrical equipment for measurement, control and laboratory use". The device therefore satisfies the statutory requirements of the EC Directives.

By applying the CE mark, Endress+Hauser confirms that the device has passed the necessary tests.

### 2.4.2 Identification in accordance with Directive 94/9/EC (ATEX)

	<b>CE  II 1/2D IP67 T99°C</b>
- Device group II	_____
- Device category:	_____
Process category 1 (zone 20),	
Environment for category 2 (zone 21)	
- Type of protection for housing in accordance with EN 60529	_____
- Maximum surface temperature at maximum permissible ambient temperature	_____

ATEX identification

### 3 Sensing weights

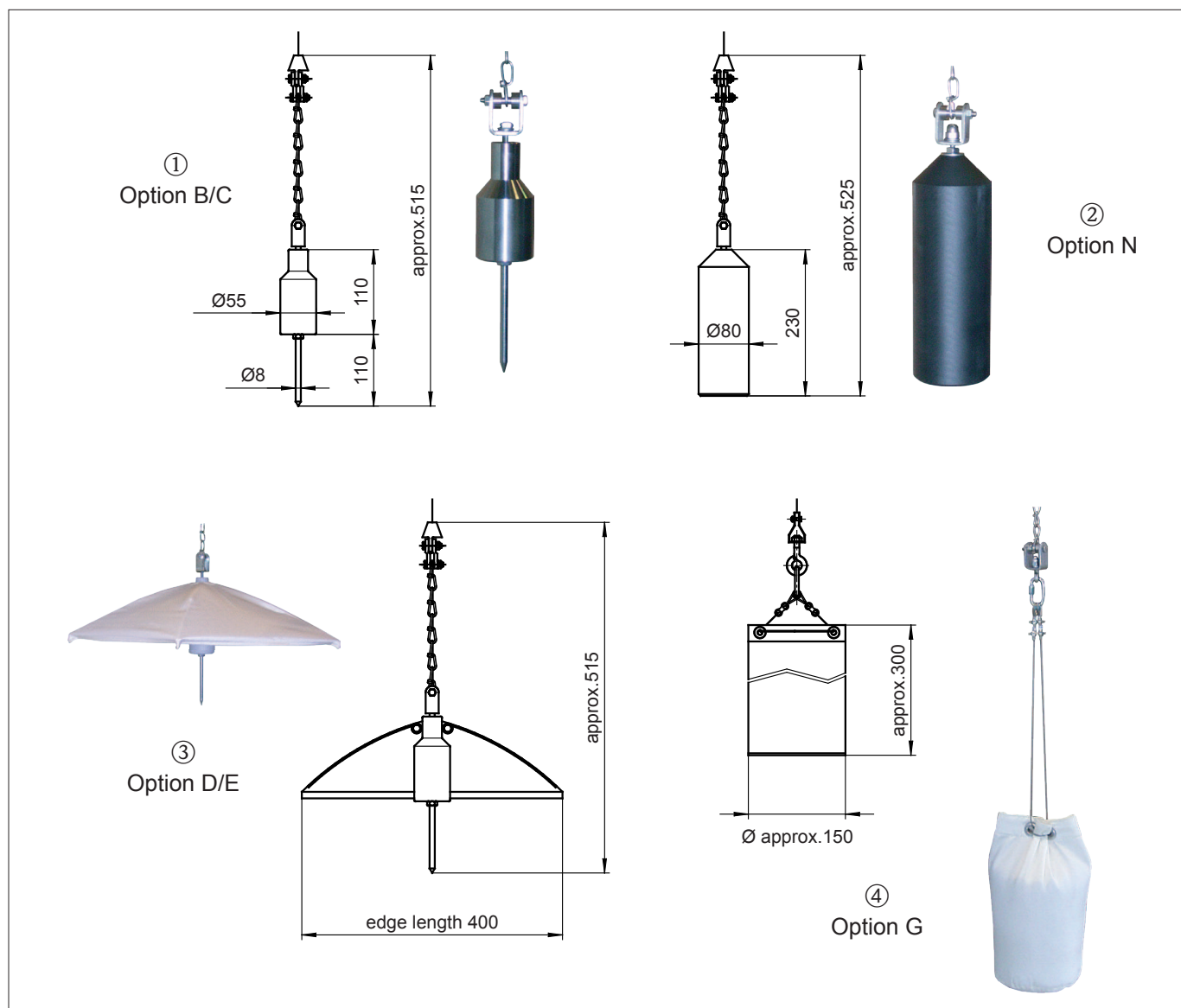

Sensing weights

#### 3.1 Variants

The following forms are available and are described on the following pages:

- Normal weight (cylindrical sensing weight with spike) ① (Option B/C)
- Plastic weight ② (Option N)
- Umbrella weight incl. normal weight ③ (Option D/E)
- Medium bag weight ④ (Option G)

### 3.1.1 Normal weight (Option B/C)

- Application:  
For coarse bulk solids, e.g. coals, ores or stones and granulates.
- Materials:  
Steel or stainless steel (316TI)
- Weight:  
1.5 kg
- The spike can be screwed off.

### 3.1.2 Plastic weight (Option N)

- Application:  
For coarse bulk solids, e.g. coals, ores or stones and granulates.
- Materials:  
Plastic (PVC)
- Weight:  
1.5 kg
- Maximum permissible temperature:  
+70°C
- Use of this sensing weight in the "dust ignition-proof" version is not permitted!

### 3.1.3 Umbrella weight (Option D/E)

- Application:  
For very light and loose bulk solids, e.g. flour or coal-dust.
- Materials:  
Steel or stainless steel (316TI) and polyester (umbrella weight)
- Weight:  
1.5 kg
- The umbrella weight has a large square surface area which prevents it from sinking deeply into the product.
- When folded closed, the weight can be passed through the DN100 mounting flange into the bunker.

### 3.1.4 Medium bag weight (Option G)

- Application:  
In bunkers to which e.g. mills are connected downstream. The bag contains whichever product is contained within the bunker.
- Materials:  
Bag made from polyester; all metal parts made from stainless steel.
- Weight:  
0.25 kg (empty) or 1.5 kg (filled)
- Bind the bag closed at the top so that the contents cannot fall out if the bag tips over on the slope of a product cone.

## 3.2 Selection recommendation

When selecting the sensing weight, the following points should be considered:

- The sensing weight must not sink into the product nor be diverted by contact with the product cone during the measuring procedure.
- The sensing weight must be suited to the chemical characteristics of the product and the temperature in the bunker or silo.

## 4 Installation

### 4.1 Planning the installation location

Select the installation location on the bunker or silo such that product falling inside during filling or cornices collapsing inward are prevented from covering the sensing weight or damaging the measuring tape.

Take due account of the shape and location of the product inflow cone and the outflow funnel within the vessel. The measuring path should not pass too close to any internal fixtures or struts so that the measuring tape will not brush against them if the sensing weight swings around.

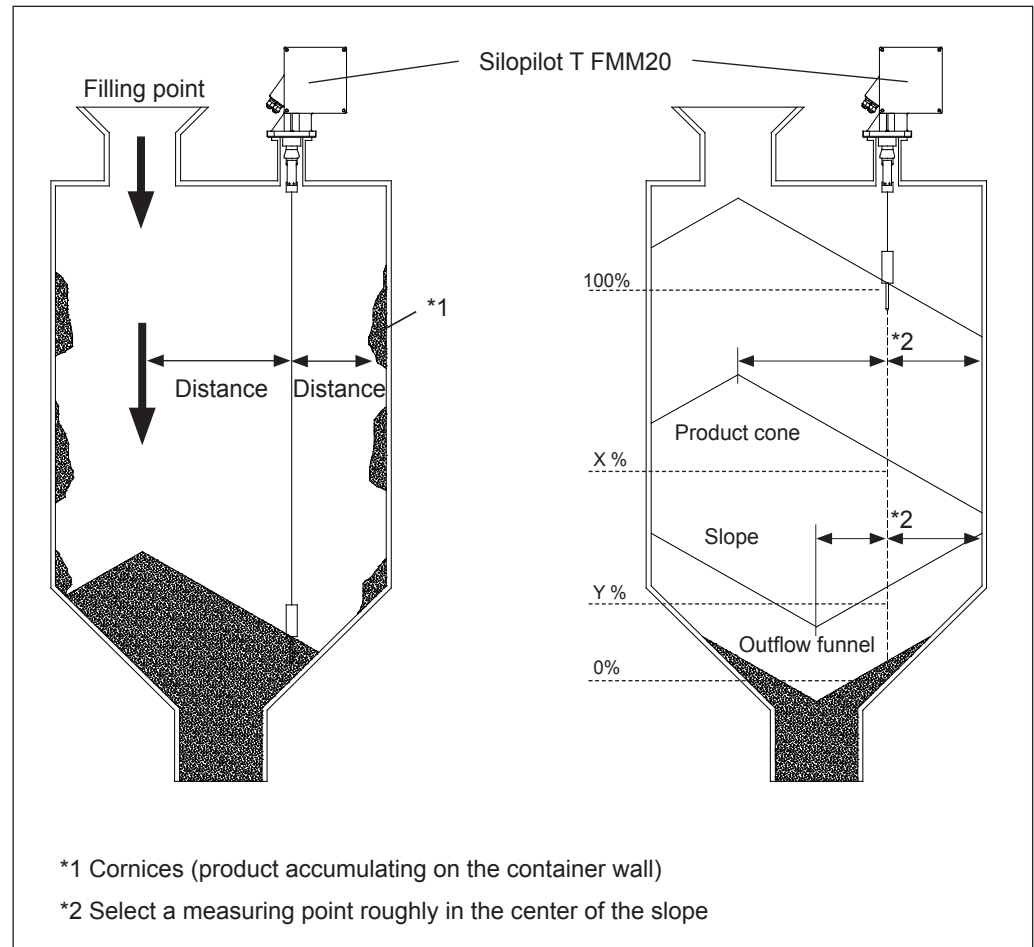

*Planning the installation location*

## 4.2 Installation conditions

### 4.2.1 Housing dimensions

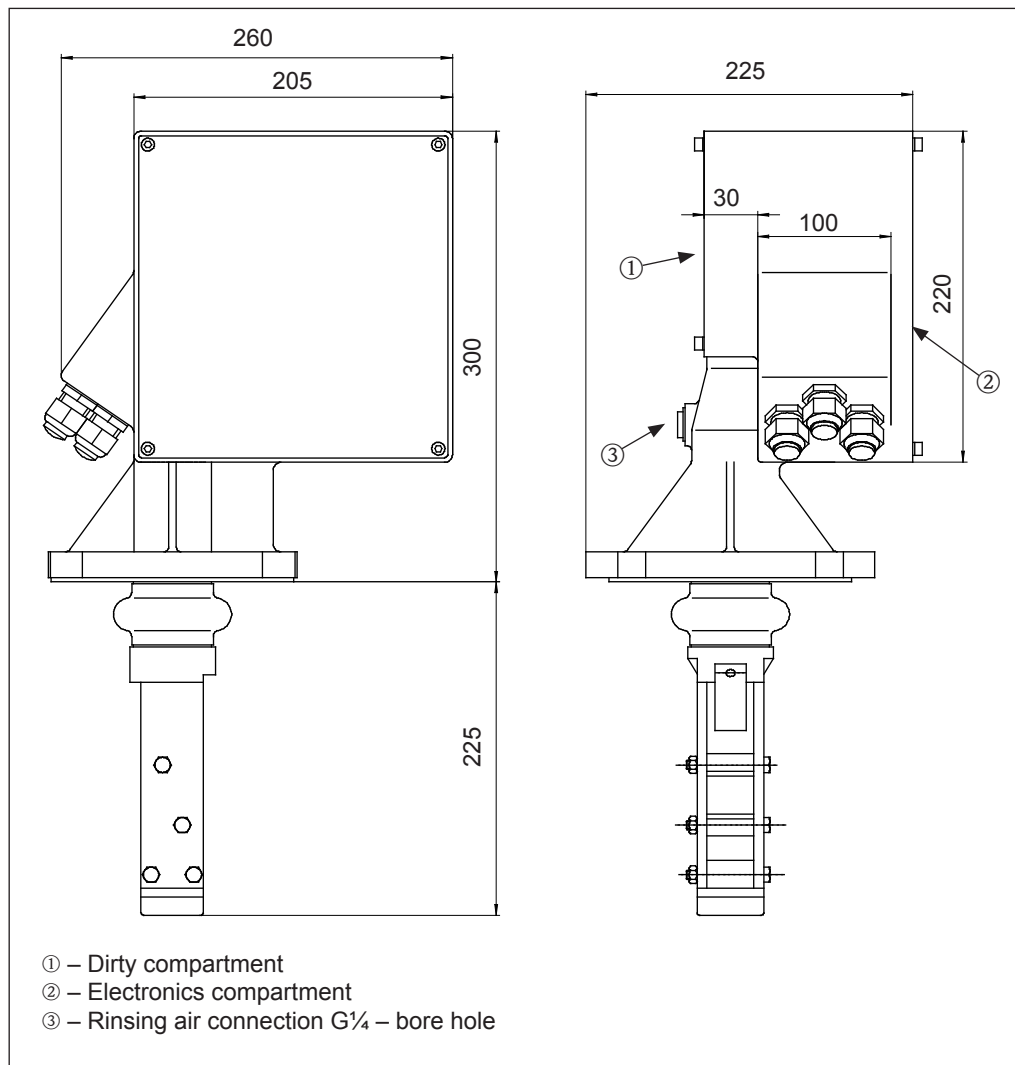

*Housing dimensions*

### 4.2.2 Dimensions of extended wiper

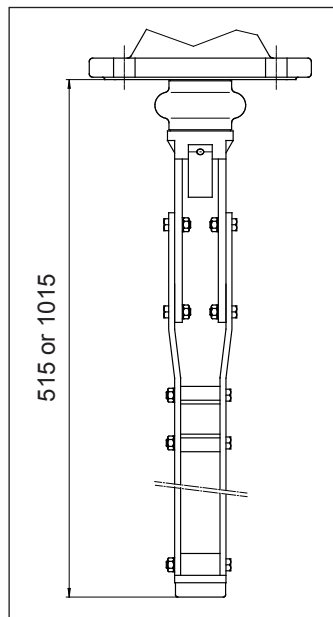

*Dimensions of the wiper extension*

### 4.2.3 Dimensions of process connection

Hole dimensions DN100 PN16 (acc. to EN 1092-1)

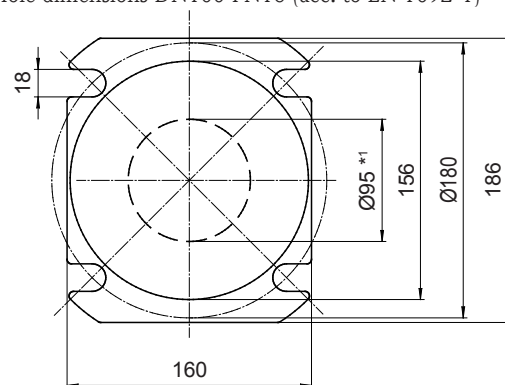

\*1 Minimum dimension for installing the wiper mechanism and standard weight

*Dimensions of process connection*

#### 4.2.4 Dimensions of optional window and external start button

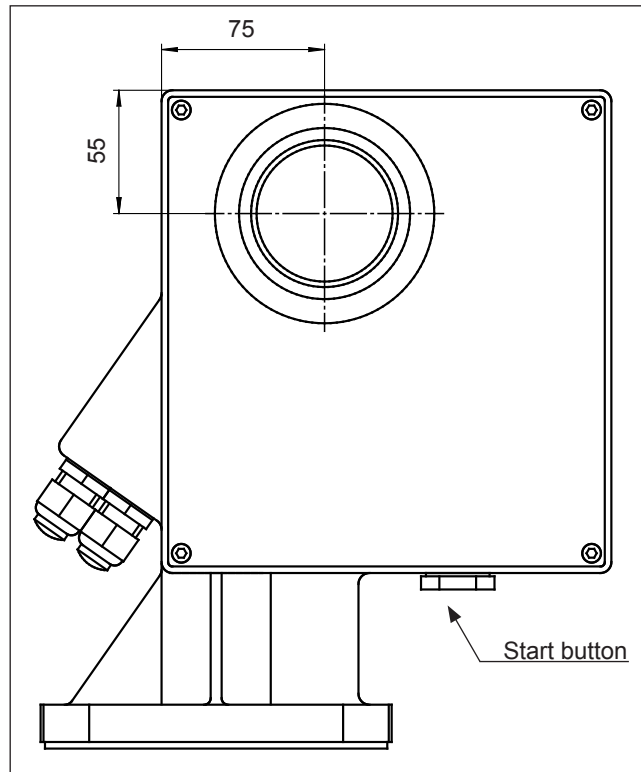

*Dimensions of window and start button*

### 4.3 Installation preparation

The Silopilot is best mounted on a counter flange DN100 PN16 (connection dimensions acc. to EN 1092-1) or a flange with the same connection dimensions. Please refer to chapter 4.2 for dimensions

The counter flange must be mounted exactly horizontal so that the Silopilot can also be mounted horizontally onto it (maximum angle of inclination 2°).

When installing outside, fit a protective hood or mount a weather protection cover.

## 4.4 Installation

### 4.4.1 Installing the sensing weight

No structural changes have to be made for the sensing weights according to order code (normal weight, umbrella weight and medium bag weight, see chapter 3 "Sensing weights"). They can be passed through the DN100 mounting flange directly into the bunker or silo.

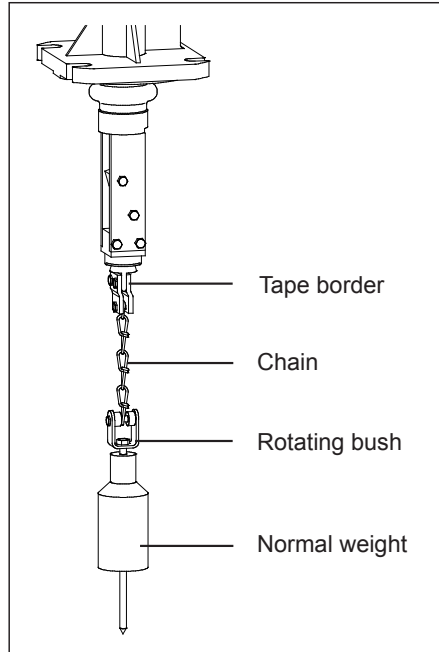

*Installing the sensing weight*

The measuring tape is pressed into the tape border using two screws. A third screw secures the chain. A rotating bush is mounted at the bottom end of the chain to accommodate any turning motion of the sensing weight.

In the delivery status of the Silopilot, the sensing weight including rotating bush and chain is supplied in a pre-assembled state. It must be secured to the tape border using the enclosed screws when on-site installation is performed.

### 4.4.2 Installing the Silopilot

Fit a seal ring on the flange (particularly if there is positive pressure in the bunker or silo). Carefully guide the sensing weight into the bunker or silo.

Now place the Silopilot onto the flange and secure it using four M16 bolts of a suitable length. Please note the following points:

- Take the position of cable entries for electrical connections into consideration (see "Housing dimensions" in chapter 4.2).
- Install the Silopilot horizontally (see chapter 4.3 "Installation preparation").



Attention!

Please remove the transport fixture in the dirty compartment before installation (see figure)! You would get unpredictable device reactions if you don't remove this transport fixture.

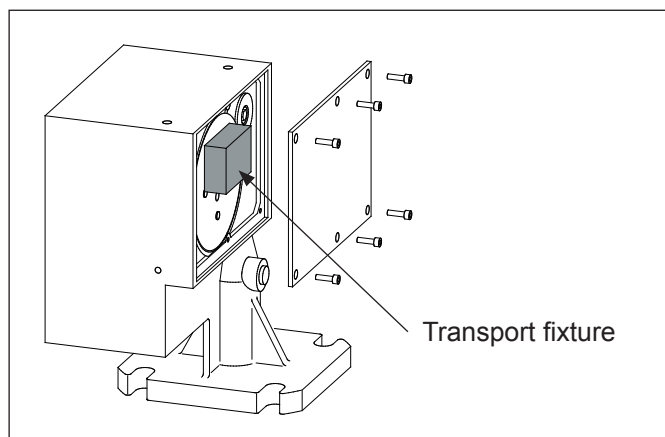

*Remove transport fixture*



**Note!**

- When installing the Silopilot in bunkers or silos with heavy dust development, slight positive pressure can be generated at the Silopilot by means of the rinsing air connection at the mounting flange (airflow quantity as required).  
There is a G $\frac{1}{4}$  female connection provided for this purpose (see "Dimensions" in chapter 4.2).
- The sensing weight must be outside the nozzle when the measuring tape is wound up (see the following illustration). The maximum height of the nozzle is defined by the length of the wiper. This is 230 mm when using the standard wiper. The wiper is also available in lengths of 500 mm and 1000 mm (see order code). Other lengths are available on request as special versions.

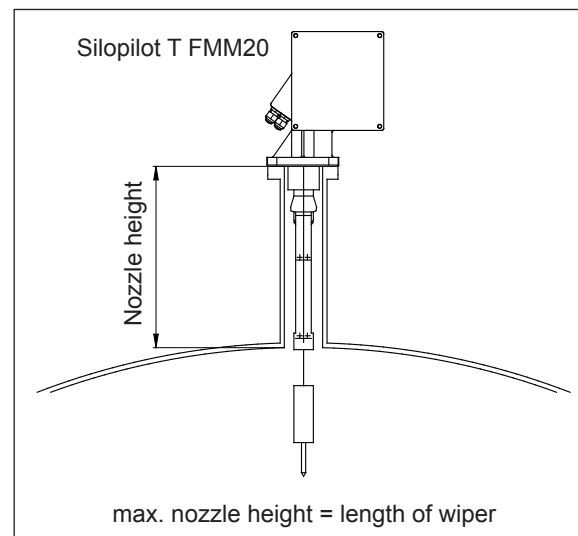

*Installing the extended wiper*

## 4.5 Incoming acceptance and storage

### 4.5.1 Incoming acceptance

Check whether the package or contents are damaged. Check that the goods supplied are complete and compare the scope of delivery with your order details.

### 4.5.2 Storage

The measuring device must be packaged with protection from impact for storage and transport. The permissible storage temperature is  $-40^{\circ}\text{C}$  to  $+60^{\circ}\text{C}$ .

## 4.6 Post-installation check

Once the measuring device has been mounted, undertake the following checks:

- Do you remove the transport fixture in the dirty compartment?
- Is the measuring device damaged (visual check)?
- Does the measuring device correspond to the specifications of the measuring point, such as process temperature, ambient temperature, measurement range, etc.?
- Are the measuring point numbers and inscriptions correct (visual check)?
- Is the measuring device sufficiently protected from rain and direct sunlight?

## 5 Wiring

### 5.1 Electrical connection

Please note the following points before connecting up the device:

- The voltage supply must match the voltage specified on the nameplate.
- Switch off the supply voltage before connecting the device.
- Connect a potential matching line to the earthing terminal to be used on the Silopilot's housing before connecting the device.
- When using the device in explosion hazard zones, the corresponding national standards and specifications must be observed.



Warning!

Always observe the safety instructions on this provided in chapter 1 of these Operating Instructions!

### 5.2 Potential matching

The potential matching should be connected up to the outer earthing terminal of the Silopilot.

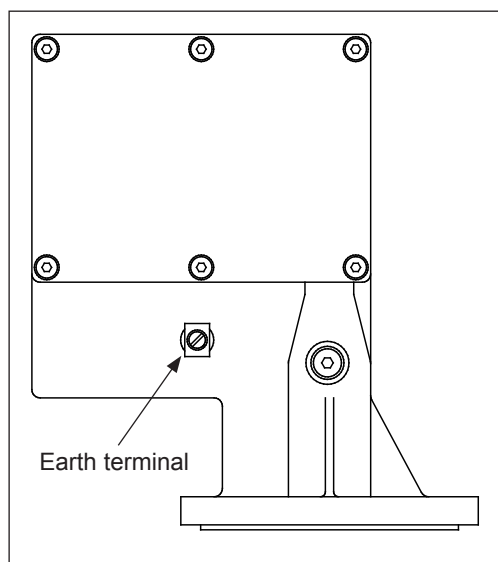

*Potential matching*



Note!

For optimum electromagnetic compatibility, the potential matching line should be as short as possible. The recommended minimum cable cross-section is 2.5 mm<sup>2</sup>.



Attention!

The Silopilot's potential matching should be included in the local potential matching.

### 5.3 Terminal assignment

#### 5.3.1 Overview

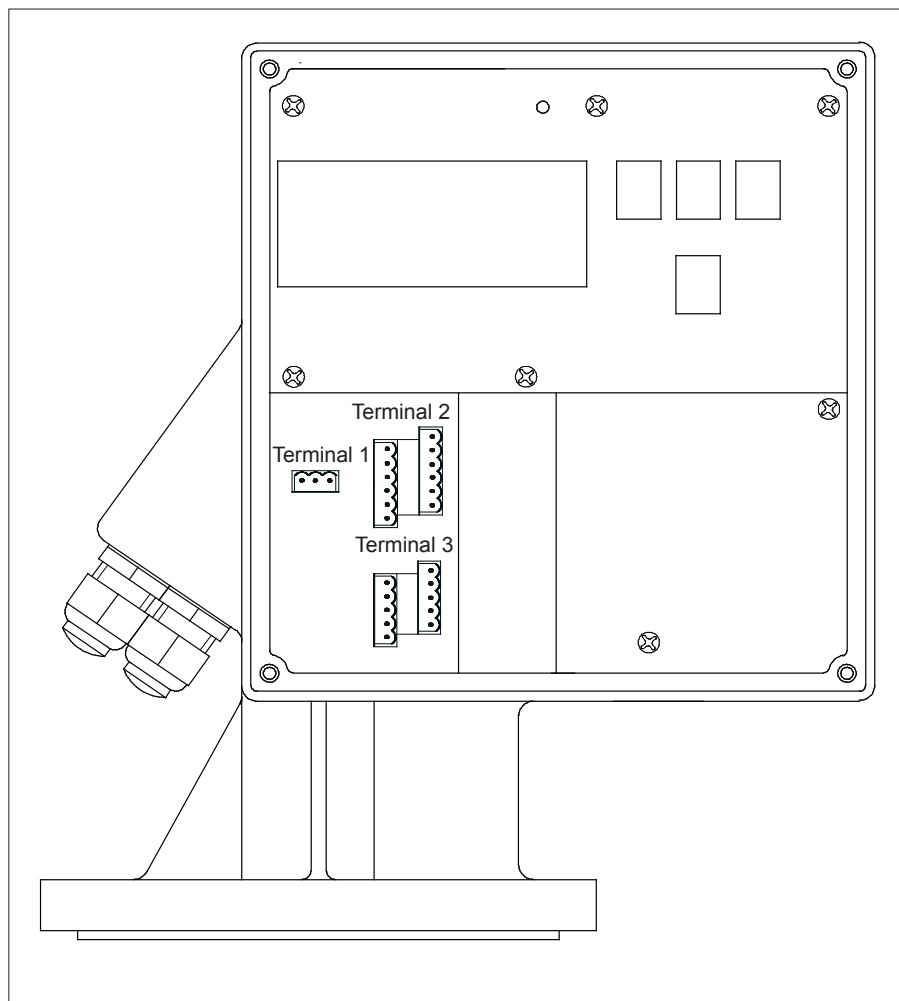

Terminal assignment

Terminal	Function
Term. 1	Supply voltage
Term. 2.1 - Term. 2.3	Relay output 1
Term. 2.4 - Term. 2.6	Relay output 2
Term. 2.7 - Term. 2.9	Relay output 3 <sup>*1</sup>
Term. 2.10 - Term. 2.12	Relay output 4 <sup>*1</sup>
Term. 3.1 - Term. 3.3	Input 1
Term. 3.6 - Term. 3.8	Input 2
Term. 3.4 - Term. 3.5	Pulse output <sup>*1</sup>
Term. 3.9 - Term. 3.10	0/4 - 20 mA current output

<sup>\*1</sup> optional (only at versions with four relay outputs)

### 5.3.2 Supply voltage

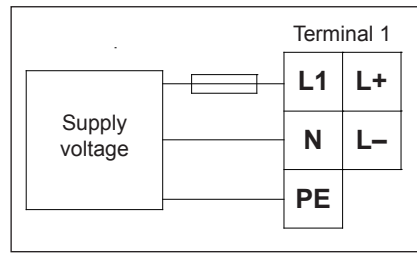

Connecting the supply voltage

- The supply voltage is connected to the plug-in terminals of terminal 1.
- The maximum cable cross-section is 2.5 mm<sup>2</sup>.
- A fuse should be fitted to protect the power supply against short circuits.
- Voltage ranges (according to order code):
  - 90 to 253 VAC, 50/60 Hz
  - 20 to 28 VDC

### 5.3.3 0/4 - 20 mA current output

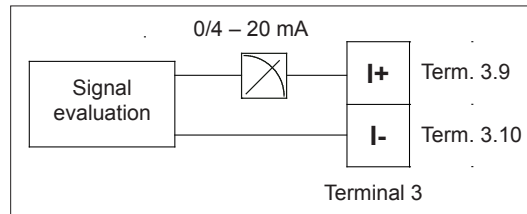

Connecting the current output

- The galvanically isolated, active 0/4 - 20 mA current output is connected to the plug-in terminals of terminal 3.
- The maximum cable cross-section for the plug-in terminals is 2.5 mm<sup>2</sup>.
- Normal installation cables are sufficient for making the connections.
- Load: max. 600 Ω

### 5.3.4 Relay outputs

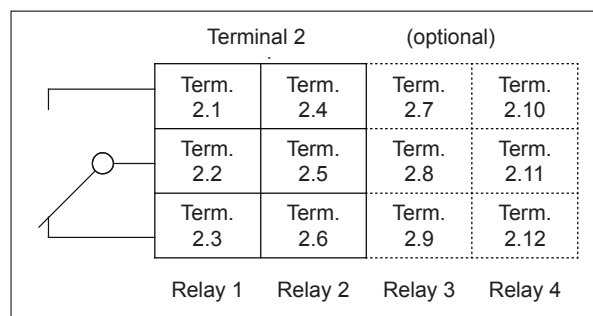

Connecting the relay outputs (rest position)

- The connection cables of the relay outputs (relay 1/2 and optional relay 3/4) are connected to the plug-in terminals of terminal 2.
- The maximum cable cross-section for the plug-in terminals is 2.5 mm<sup>2</sup>.
- Normal installation cables are sufficient for making the connections.
- The individual circuits must have a maximum of 6 A fuse protection.
- Contact load bearing capacity: 250 VAC, 6 A

### 5.3.5 Signal inputs

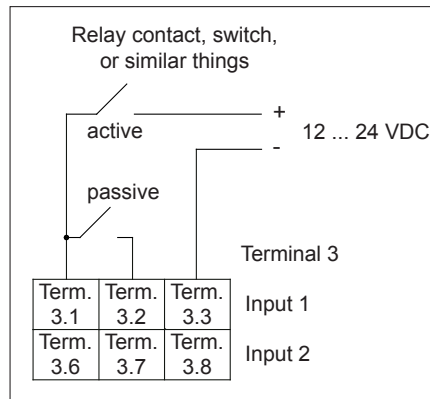

Connecting the signal inputs

- The signal inputs are connected to the plug-in terminals of terminal 3.
- The maximum cable cross-section for the plug-in terminals is 2.5 mm<sup>2</sup>.
- Normal installation cables are sufficient for making the connections.
- Input voltage range: 12 – 24 VDC



**Note!**

- The signal inputs (active/passive) can only be used alternatively. A double connection from input x active and passive cannot be used!
- In the device version with an external start button (Silopilot T FMM20 - \*\*\*\*\*2), this is connected to the passive signal input 1. Only signal output 2 is then available to you as active or passive.
- A start pulse must be present for at least 200 ms for it to be evaluated!

### 5.3.6 Optocoupler output (optional when 4 relays are selected)

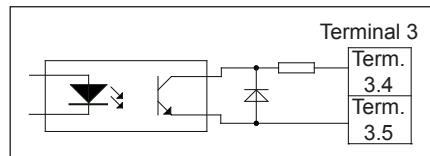

Connecting the optocoupler output

- When using the "counter pulse" output function, the counter pulses on the device version with four relay outputs can be sent to an optocoupler output parallel to relay 4.
- The connection cables of the optoelectronic coupler output are connected to the plug-in terminals of terminal 3.
- The maximum cable cross-section for the plug-in terminals is 2.5 mm<sup>2</sup>.
- Normal installation cables are sufficient for making the connections.
- Electrical data:
  - I = max. 10 mA
  - U = max. 30 VDC

### 5.4 Post-connection check

Please undertake the following checks after wiring up the measuring device:

- Is the terminal assignment correct?
- Is the cable gland sealed?
- If power supply is present:
  - Is the measuring device ready and is the LC display lit up?
- Is the housing cover screwed shut?

## 6 Operation

### 6.1 Quick operation guide

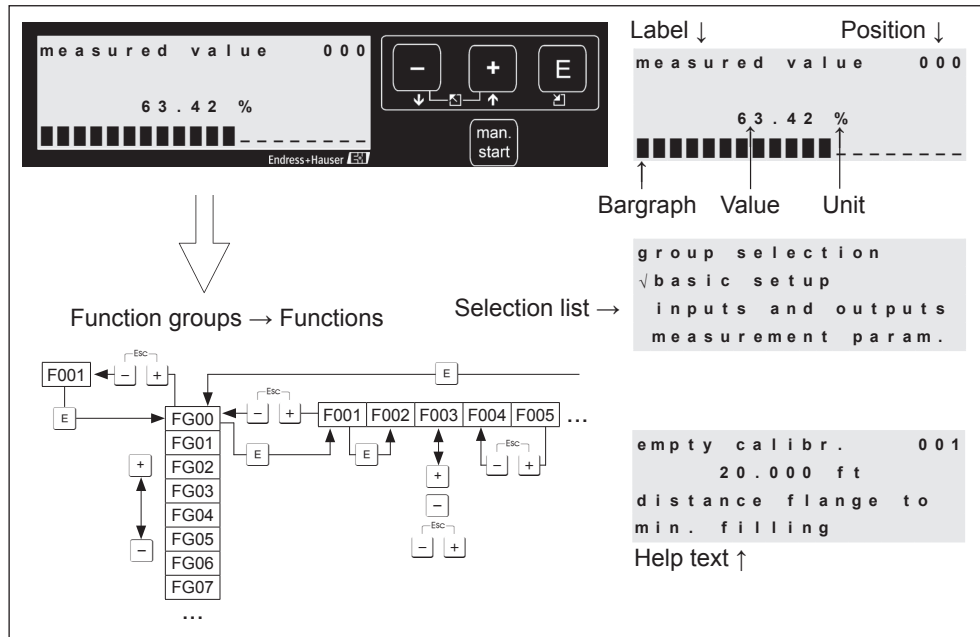

Operation

#### Selection and configuration in the operating menu:

1. Use **[E]** to switch from the measured value display to **group selection**.
2. Use **[←]** or **[→]** to select the **function group** required (e.g. "safety settings (04)") and confirm with **[E]**. The first **function** (e.g. "output on alarm (040)") is selected.



Note!

The active selection is indicated by a ✓ in front of the menu text!

3. Editing mode is activated by pressing **[+]** or **[−]**.

#### Selection menus:

- a) In the **function** selected (e.g. "output on alarm (040)"), **[←]** or **[→]** can be used to select the parameter required.
- b) **[E]** confirms the selection. ✓ appears in front of the parameter selected.
- c) **[E]** confirms the value edited. Editing mode is quit.
- d) **[+] + [−]** (= **[↵]**) cancels the selection. Editing mode is quit.





#### Numbers and text entry:

- a) The first digit of the **number/text** can be edited by pressing **[+]** or **[−]** (e.g. "output on alarm (040)").
  - b) **[E]** moves the input screen to the next digit. Continue with (a) until the value has been fully entered or modified.
  - c) When the symbol "→" appears in the input screen, use **[E]** to adopt (save) the value
  - d) **[+] + [−]** (= **[↵]**) cancels the entry. Editing mode is quit.
4. Use **[E]** to select the next **function** (e.g. "safety distance (042)").
  5. Entering **[+] + [−]** (= **[↵]**) takes you back to the last **function**.  
 Entering **[+] + [−]** (= **[↵]**) again takes you to **group selection**.  
 Entering **[+] + [−]** (= **[↵]**) again takes you back to **the measured value display**.

## 6.2 Display and operating elements

















### 6.2.1 Display symbols

The following table describes the symbols used in the display:

Symbol	Meaning
	<p><b>Alarm symbol</b></p> <ul style="list-style-type: none"> <li>- This alarm symbol is shown when the device is in an alarm status (error status).</li> <li>- If the symbol is flashing, a fault has occurred.</li> </ul>
	<p><b>Lock symbol</b></p> <ul style="list-style-type: none"> <li>- This lock symbol is when the device is locked, i.e. when no energy is available.</li> </ul>
	<p><b>Hand symbol</b></p> <ul style="list-style-type: none"> <li>- This symbol flashes when the device is in the "manual mode" type of measurement.</li> <li>- When the  or  button is pressed, the symbol disappears and the direction selected (run-up ↑ or run-off ↓) is shown.</li> </ul>

### 6.2.2 Function of buttons

The following table describes the function(s) of the individual buttons:

Button(s)	Meaning
 or 	<ul style="list-style-type: none"> <li>- Upwards navigation in the selection list</li> <li>- Edit the numerical values within a function</li> </ul>
 or 	<ul style="list-style-type: none"> <li>- Downwards navigation in the selection list</li> <li>- Edit the numerical values within a function</li> </ul>
  or 	- Navigation to the left within a function group
	<ul style="list-style-type: none"> <li>- Navigation to the right within a function group</li> <li>- Confirmation</li> </ul>
 and  or  and 	<p>Contrast setting of the liquid crystal display</p> <ul style="list-style-type: none"> <li>-  and  increases the contrast</li> <li>-  and  reduces the contrast</li> </ul>
 or external start button	- Starts measurement process (provided that the Silopilot is in the measured value display function)

### 6.2.3 LED

The green LED positioned above the LC display is used to display the pulse of the counting wheel during a measurement process. The counting wheel emits a pulse to the evaluation electronics every 2.5 cm of running. The status of the LED changes at the same time. Once the measurement process is complete, the last LED status is retained.

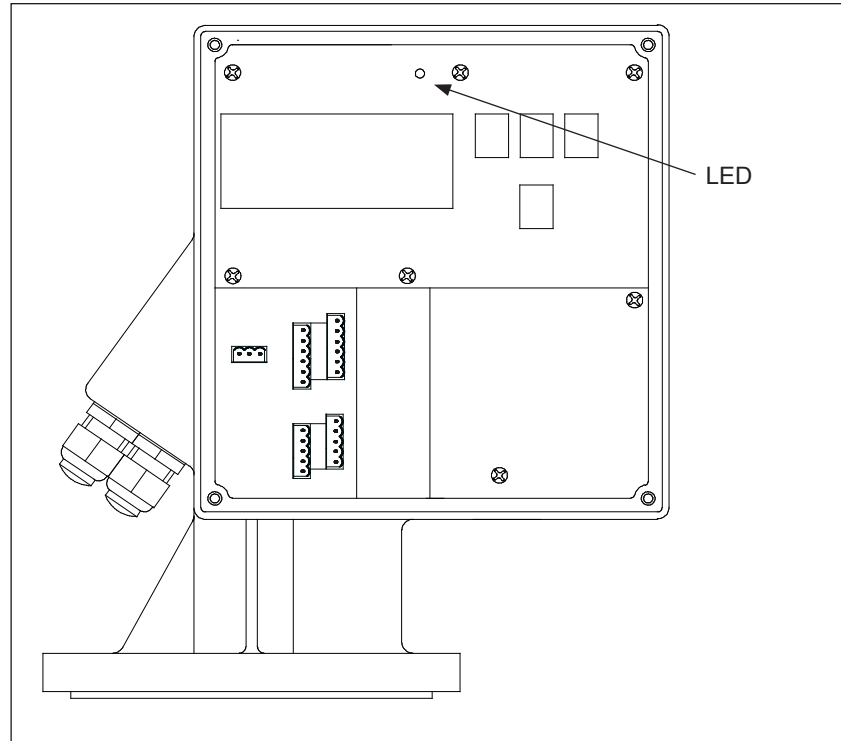

*LED for displaying the counting wheel pulses*

## 6.3 General structure of operating menu

The operating menu consists of two levels:

- **Function groups (00, 01, to 08):**

The individual possible ways of operating the device are divided roughly into function groups. Function groups available are e.g.: "**basic setup (00)**", "**inputs and outputs (01)**", "**safety settings (04)**", etc.

- **Functions (001, 002, to 083):**

Each function group consists of one or more functions. The actual operation and/or setting of parameters for the device takes place in the functions. Numerical values can be entered here and parameters selected and saved. Functions available from the "**inputs and outputs (01)**" function group are e.g.:

"**input 1 (010)**", "**input 2 (012)**", "**relay output 1 (014)**", etc.

If, for example, the function of relay for output 1 is to be changed, the following procedure applies:

1. Select the function group "**inputs and outputs (01)**"
2. Select the function "**relay output 1 (014)**"
3. Select e.g. "counter pulses"







## 7.2 Basic setup

In most cases, the basic setup is sufficient for successful commissioning. More complex measurement tasks may however require further settings. For the details of all functions, please see chapter 8.

You will find a table in the appendix detailing the values preset in the factory.

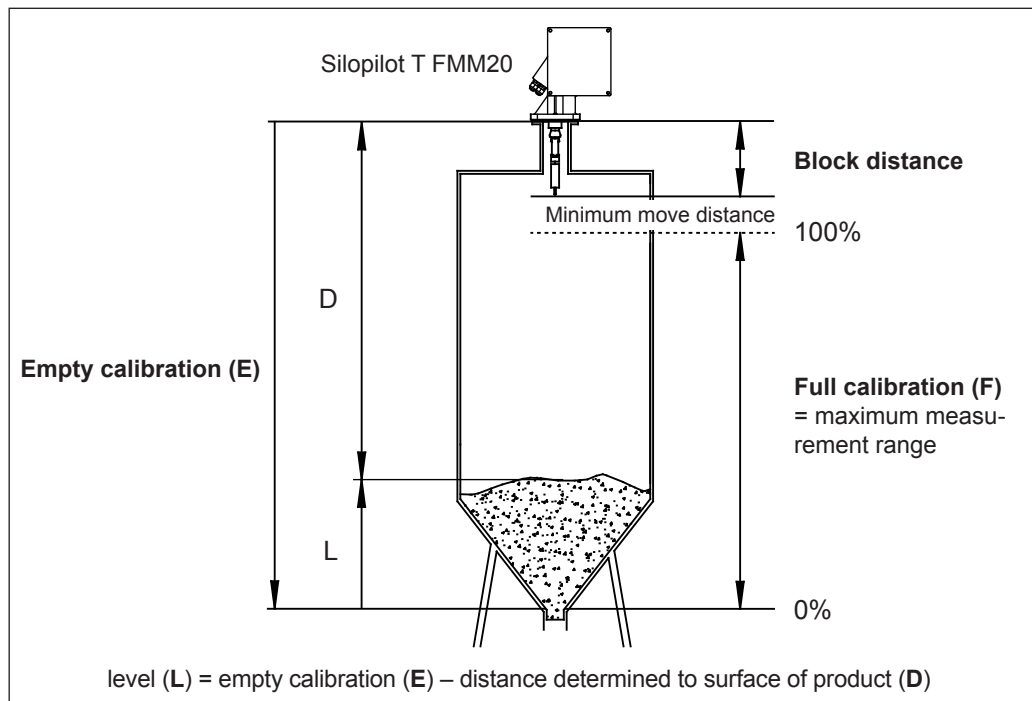

Basic calibration

### 7.2.1 Empty calibration (001)

```
empty calibr. 001
      32 m
distance flange to
min. filling
```

With this function, you enter the distance between the mounting flange (reference point for measurement) and the minimum fill level (=zero point).

Range of values: 1 m to length of measuring tape (or converted value in feet/inches)

Default value: Length of measuring rope/tape

### 7.2.2 Block distance (002)

```
block distance 002
      0.72 m
distance flange to
bottom weight
```

With this function, you enter the distance between the flange of the Silopilot and the end of the sensing weight (in upper limit position).

Range of values: 0.23 m to 5 m (or converted value in feet/inches)

Default value: 0.72 m

### 7.2.3 Full calibration (003)

```
full calibration 003
      31 m
measuring range
max. = empty - bd
```

With this function, you enter the distance between the minimum fill level (=zero point) and maximum fill level (=measurement range).

Range of values: 1 m to empty calibration - block distance (or converted value in feet/inches)

Default value: Length of measuring tape - 0.72 m

### 7.2.4 Measurement type (020)

```
measurement type 020
√single cycle
periodical
manual
```

With this function, you select the type of measurement for the Silopilot:

- **single cycle:** A single measurement can be activated manually using buttons on the device or using a corresponding input signal (see chapter 8.2).
- **periodical:** The Silopilot can take time-controlled measurements. The time interval can be defined in functions 021 and 022 (see chapter 8.3).
- **manual:** The Silopilot can only be operated using the buttons on the device. This type of measurement gives the user the opportunity to move the sensing weight slowly (e.g. when changing the sensing weight). For a precise description of this type of measurement, please refer to chapter 9.

Default value: single cycle

## 8 Description of device functions

### 8.1 "basic setup (00)" function group

In most cases, basic setup is sufficient for successful commissioning. More complex measurement tasks may however require further settings.

Please refer to this and the following sections for details. You will find a table in the appendix to these Operating Instructions detailing the values preset in the factory.

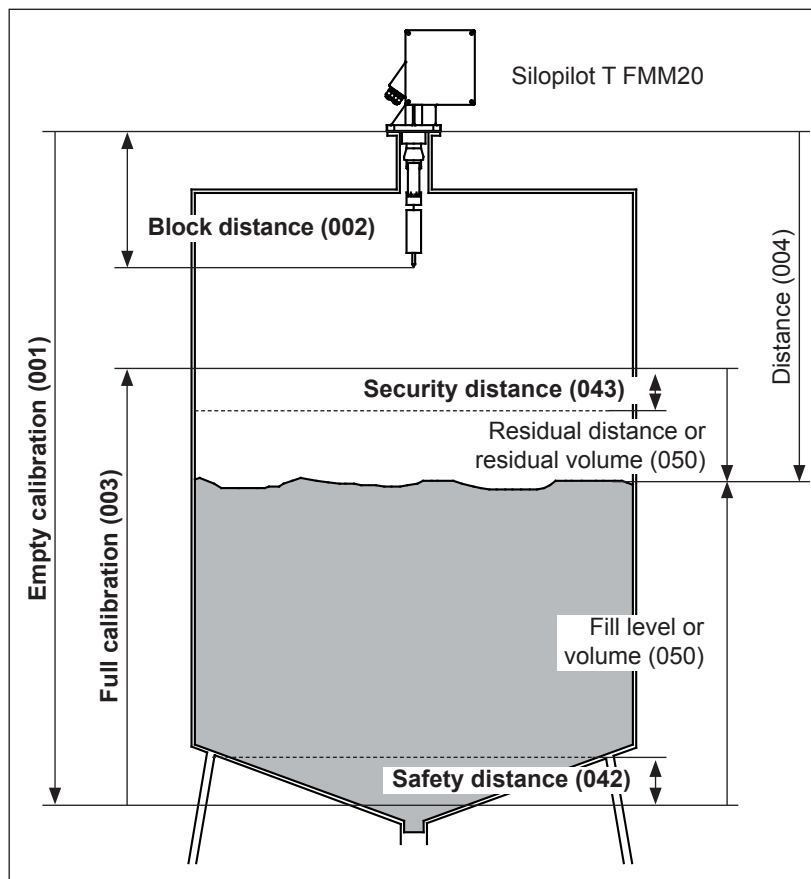

Basic setup functions

#### 8.1.1 Empty calibration (001)

```
empty calibr.    001
                 32 m
distance flange to
min. filling
```

With this function, you enter the distance between the mounting flange (reference point for measurement) and the minimum fill level (=zero point).

Range of values: 1 m to length of measuring tape (or converted value in feet/inches)

Default value: Length of measuring tape

#### 8.1.2 Block distance (002)

```
block distance  002
                 0.72 m
distance flange to
bottom weight
```

With this function, you enter the distance between the flange of the Silopilot and the end of the sensing weight (in upper limit position).

Range of values: 0.23 m to 5 m (or converted value in feet/inches)

Default value: 0.72 m

### 8.1.3 Full calibration (003)

```
full calibration 003
          31 m
measuring range
max.=empty-bd
```

With this function, you enter the distance between the minimum fill level (=zero point) and maximum fill level (=measurement range).

Range of values: 1 m to empty calibration - block distance (or converted value in feet/inches)

Default value: Length of measuring tape - 0.72 m

### 8.1.4 Measurement type (020)

```
measurement type 020
√single cycle
periodical
manual
```

With this function, you select the type of measurement for the Silopilot:

- **single cycle:** A single measurement can be activated manually using buttons on the device or using a corresponding input signal (see function 010).
- **periodical:** The Silopilot can take time-controlled measurements. The time interval can be defined in the functions 021/022.
- **manual:** The Silopilot can only be operated using the buttons on the device. This type of measurement gives the user the opportunity to move the sensing weight slowly (e.g. when changing to larger sensing weights). For a precise description of this type of measurement, please refer to the corresponding chapter.

Default value: single cycle



#### Warning!

When in manual mode, the upper limit switch and the loose band switch have no function! Users must themselves ascertain the position in which the sensing weight is currently located. With this type of measurement, the sensing weight can (depending on the maximum tape length) be lowered into unauthorized areas of the container (or e.g. in an outlet worm).



#### Note!

A measurement can only be taken when the device is in the measured value display (000). This also applies to the device version with an external start button.

### 8.1.5 Distance/measured value (004)

```
dist./meas.value 004
distance 0.90 m
meas.val 3.75 %
```

With this function, you can display the distance measured between the Silopilot and product and the current measured value. The display depends on the digits after the decimal place (function 062) and the length unit (function 083).

## 8.2 "inputs and outputs (01)" function group

The entries made in this function group determine the characteristics of the inputs and relay outputs.

### 8.2.1 Input 1 (010)

```
input 1      010
√not used
bolting
start measurement
```

With this function, you determine the characteristics of input 1:

- **not used**
- **bolting:** If there is a signal at input 1, the Silopilot is blocked for further measurements. If necessary, the sensing weight is moved into the upper limit position, the measurement is canceled immediately.
- **start measurement:** If there is a signal at input 1, the Silopilot starts a new measurement.

Default value: not used



Note!

In the device version with an external start button, this is connected to input 1. The function is then set to "start measurement" in the factory.

### 8.2.2 Input 2 (012)

```
input 2      012
√not used
bolting
start measurement
```

With this function, you determine the characteristics of input 2. The selection options available are identical to those for input 1.

Default value: not used

### 8.2.3 Relay output 1 (014)

```
relay output 1 014
√counter pulses
reset pulse
running up
```

With this function, you determine the characteristics of the relay for output 1:

- **alarm:** Relay switches as soon as an error (e.g. tape breakage or burying) is detected.
- **service interval:** Relay switches when the value set in the maintenance interval (024) function is reached.
- **counter pulses:** Relay switches at the pulse value set in function 015 and with the counter pulse length set in function 016.
- **reset pulse:** Relay switches at the reset pulse length set in function 019 before a new measurement. This output can be used to reset an external counter.
- **running up:** Relay switches when running up the sensing weight.
- **top position:** Relay switches as soon as the upper limit position of the sensing weight (end of measurement) is reached.
- **measuring:** Relay switches during the entire Silopilot measuring period.

Default value: alarm

### 8.2.4 Relay for output 2 (01A) to relay for output 4 (01C)

The functionality of the outputs correspond to those of the relay for output 1 (see function 014). Relay outputs 3 (01B) and 4 (01C) are only available as options. Please refer to the product structure in chapter 2 for details.

Default value:

relay output 2 (01A)	service interval
relay output 3 (01B)	measuring
relay output 4 (01C)	top position

### 8.2.5 Pulse value (015)

```
Pulse weight      015
      1
length per pulse
output = value*2.5cm
```

With this function, you enter the move distance per pulse at the counting output. The distance is calculated from the value set  $\times 2.5$  cm.

Range of values: 1 to 20 (= 2.5 cm to 50 cm or the value converted into feet/inches)

Default value: 1

Example (see illustration):

Every 0.2 m of move distance (pulse value = 8) the preset counting pulse output e.g. relay 1 issues a counting pulse. You can enter the length of this pulse in the "**pulse length (016)**" function.

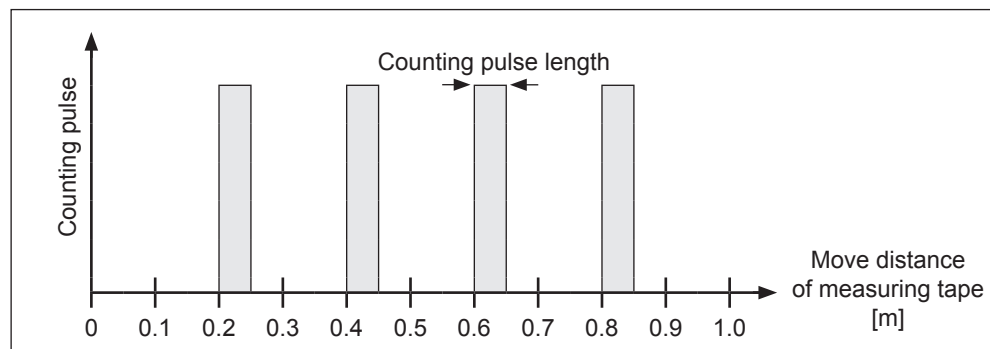

*Pulse value*

### 8.2.6 Pulse length (016)

```
Pulse length      016
      50 ms
length of the
counter pulse
```

With this function, you enter the length of the counter pulses in milliseconds. In such cases, the range of values depends on the pulse value (015).

Range of values: 30 ms to 100 ms [pulse value = 1]  
 30 ms to 250 ms [pulse value = 2]  
 30 ms to 400 ms [pulse value = 3]  
 30 ms to 550 ms [pulse value = 4 to 20]

Default value: 50 ms

### 8.2.7 Reset pulse (019)

```
reset pulse      019
      300 ms
length of the
reset pulse
```

With this function, you determine the length of the reset pulse of the relay outputs, when e.g. "reset pulse" has been selected in function 014, in milliseconds.

Range of values: 30 ms to 1000 ms

Default value: 300 ms



### 8.3 "measurement parameters (02)" function group

#### 8.3.1 Measurement type (020)

```
measurement type 020
√single cycle
periodical
manual
```

With this function, you select a type of measurement for the Silopilot. You will find a precise description of this function in the "basic setup" section (chapter 7.2.4).

Default value: single cycle

#### 8.3.2 Time interval (021)

```
time interval 021
1 h
```

With this function, you enter a value for the time interval for the "periodical" type of measurement (see function 020). You enter the unit of this value (minutes or hours) in function 022.

Range of values: 1 to 60 (minutes or hours)

Default value: 1



#### Attention!

When operating the Silopilot, please observe the minimum time ( $T_M$ ) for a measurement cycle depending on the measurement range (MR). We recommend:

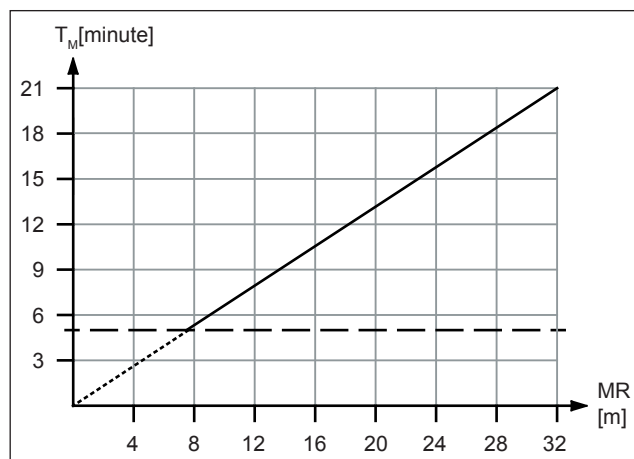

#### 8.3.3 Time unit (022)

```
time unit 022
√h
min.
```

With this function, you enter the unit of the time interval from function 021.

- min.: minute(s)
- h: hour(s)

Default value: h

### 8.3.4 Normal or short (023)

```
normal or short 023
√normal
short
```

With this function, you select the operating mode for the measurement (with the "single cycle" and "periodical" types of measurement):

- **normal:** At the start of a measurement, the Silopilot lowers the sensing weight down to the product, the sensing weight is then pulled back into the upper limit position.
- **short:** At the start of a measurement, the Silopilot lowers the sensing weight down to product, but the sensing weight is then only raised by one meter. An input for the lock (i.e. when the input is active, the sensing weight immediately moves to the upper limit position) should be used because the sensing weight is not protected against burying in this operating mode. The upper limit position is approached every 20 measurement cycles.

Default value: normal



Note!

Depending on silo height and fill level, the "short" operating mode can considerably shorten the length of a measurement cycle. Disadvantages of this operating mode:

- By selecting the appropriate settings, the user must ensure that the sensing weight is not buried.
- There is little point in using the "counter pulses" output function because the Silopilot does not approach a defined point (and therefore no defined distance) at the end of a measurement.

### 8.3.5 Service interval (024)

```
service interval 024
45000
num. of measurements
til tape/rope change
```

With this function, you specify the number of measurement cycles before the next maintenance (including tape changes) is undertaken. If the set value is reached, the Silopilot issues a warning. The "service interval" relay output switches. The warning and/or switched relay output can be reset by resetting the service interval counter in function 025.

Range of values: 1 to 90000

Default value: 45000



Note!

The number of Silopilot measurements before the next round of maintenance work depends on the process environment. The user should adjust this value depending on the level of dirt and/or measuring tape condition!

### 8.3.6 Service interval counter (025)

```
serv.int.counter 025
5678
```

With this function, you can change the internal counter for the service interval, e.g. for resetting purposes once the service interval has been reached (see function 024).

Range of values: 0 to 90000

### 8.3.7 Simulation (026)

```
simulation      026
√sim. off
sim. level
sim. volume
```

Simulation mode allows the user to simulate a particular measured value, e.g. in order to check downstream process control systems. The relay outputs can also be checked. During simulation, the measured value display (function 000) shows the alarm symbol.

The following simulations can be selected:

- **sim. off:** Simulation is switched off.
- **sim. level:** A fill level can be specified in function 027. In such cases, the range of values conforms with the upper-range value entered in function 057. The value entered is shown in the measured value display. The current output follows the simulation value.
- **sim. volume:** A volume can be specified in function 027. In such cases, the range of values conforms with the upper-range value entered in function 057. The value entered is shown in the measured value display. The current output follows the simulation value.
- **sim. current:** A current value can be specified in function 027. The measured value display continues to show the last measured value.

Default value: sim. off



#### Note!

When in simulation mode, normal measuring with the Silopilot is not possible.

- If the device was in manual mode before simulation was activated, the sensing weight remains in its current setting.
- If the device was in measuring mode before simulation was activated, this mode remains active. The last measured value is saved internally and once the simulation is ended, is shown in the measured value display.
- If the device was in individual measurement mode before simulation was activated, this mode is no longer active. The inputs and the "man.start" button are deactivated. A measurement which has already been started is normally ended, measured value is saved internally and once the simulation is ended, is shown in the measured value display.

### 8.3.8 Simulation value (027)

```
sim. value 027
  10.00 mA
```

With this function, you enter a value for the type of simulation selected in function 026.

Range of values: 0 to 99 m (fill level)  
0 to 22.00 mA (current)  
0 to 100 000 (volume)

#### Example of fill level simulation

Silopilot settings:

Function	Function number	Input/value
empty calibration	001	20 m
full calibration	003	15 m
Fill level/volume	050	TU (technical unit)
customer unit	056	m <sup>3</sup>
max. scale	057	1000

1. simulation (026) = level  
sim. value (027) = 800  
→ Display (000) = 800 m<sup>3</sup>  
Current output = 16.8 mA
2. simulation (026) = fill level  
sim. value (027) = 200  
→ Display (000) = 200 m<sup>3</sup>  
Current output = 7.2 mA

### 8.4 "current output (03)" function group

#### 8.4.1 Current range (033)

```
current range 033
√4-20mA
0-20mA
```

With this function, you determine the range of the current output.

- 0 - 20 mA
- 4 - 20 mA

Default value: 4 - 20 mA



Note!

The characteristics of the current output can be influenced using the "level/volume (050)" function as follows:

- The "level CU" or "level DU" cause an increasing output current when the fill level (H) rises.
- In contrast, the "ullage CU" or "ullage DU" settings cause a declining output current when the fill level (H) rises.

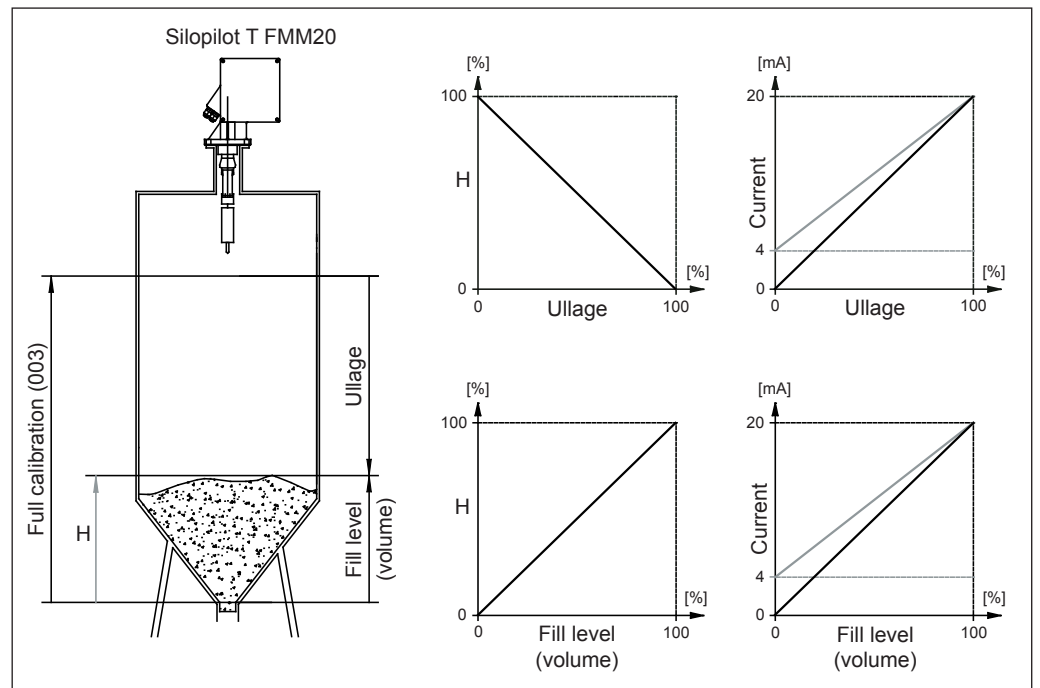

Current output

## 8.5 "safety settings (04)" function group

### 8.5.1 Output on alarm (040)

```
output on alarm 040
√MIN (0/3.6mA)
  MAX (22mA)
  hold
```

With this function, you determine the characteristics of the current output in the event of an error:

- **MIN (0/3.6mA):** If the Silopilot detects an error (e.g. rope/tape tearing off), the current falls to 0 mA or 3.6 mA (depending on function 033).
- **MAX (22mA):** If the Silopilot detects an error, the current increases to 22 mA.
- **hold:** If the Silopilot detects an error, the last current output is retained.
- **user-specific.:** If the Silopilot detects an error, the current set in function 041 is output.

Default value: MIN (0/3.6mA)

### 8.5.2 Output on alarm (041)

```
output on alarm 041
  3.60 mA
```

With this function, you determine the user-specific current value in the event of an error (see function 040).

Range of values: 0 to 22.00 mA

Default value: 3.60 mA

### 8.5.3 Safety distance (042)

```
safety distance 042
  1.00 m
minimum distance
to empty calibration
```

With this function, you determine the minimum distance e.g. to an outlet worm. This function prevents the measuring tape from running out into an unauthorized area of the silo/bunker (also see "basic setup" in chapter 8.1).

Range of values: 0 m to (full calibration - safety distance)  
(or converted value in feet/inches)

Default value: 0 m

### 8.5.4 Security distance (043)

```
security dist. 043
  0.00 m
minimum distance
to full calibration
```

A configurable safety zone is set up underneath the maximum full calibration (function 003). This zone is used to warn the user that if the fill level continues to rise future measurements could be invalid if the current measured value leaves the range of the maximum full calibration.

Range of values: 0 m to (full calibration - safety distance)  
(or converted value in feet/inches)

Default value: 0 m

### 8.5.5 In security distance (044)

```
in security dist 044
√warning
  alarm
```

With this function you can select the device reaction, if the fill level reaches the security distance (function 043). This function is only available if the value in "security distance" function (043) is greater than zero.

- **alarm**
- **warning**

Default value: warning

### 8.5.6 in safety dist. (045)

```
in safety dist. 045
√alarm
warning
```

With this function you can select the device reaction, if the fill level reaches the safety distance (function 042). This function is only available if the value in "safety distance" function (042) is greater than zero.

- **alarm**
- **warning**

Default value: alarm

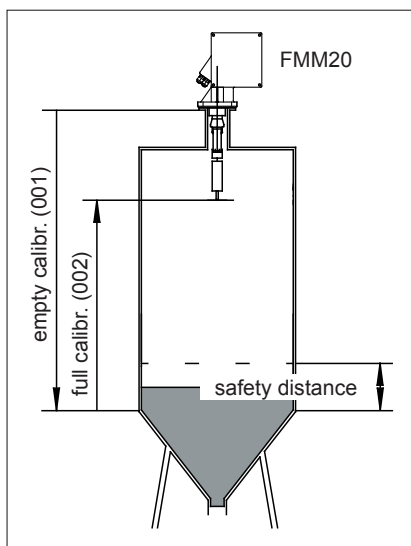

Safety distance

#### Behaviour of the FMM20 at the achievement of the safety distance:

1. "in safety distance" (045) = warning
  - The sensing weight stops.
  - The actual measurement is completed with a new measuring value.  
(measuring value (level) = full calibration (002) – safety distance (042))
  - The current value of the current output represents the measuring value.
  - The warning W661 is shown on the display (error symbol flashes).
2. "in safety distance" (045) = alarm
  - The sensing weight stops.
  - The actual measurement is disapproved (last valid measuring value is displayed).
  - The current value of the current output represents the value you select in the function "output on alarm" (040).
  - The alarm A660 is shown on the display (error symbol flashes permanent).
  - The relay with the programmed alarm function drops out.

## 8.6 "linearization (05)" function group

### 8.6.1 Level/volume (050)

```
level/volume      050
√level CU
  level DU
  ullage CU
```

With this function, you determine the display value in the measured value display function (000).

- **level CU:** Depiction of fill level in customer units. The unit can be selected or deselected in the "customer unit" function (056), and the maximum scale value in the "max. scale" function (057).
- **level DU:** Depiction of the fill level in the "distance unit" function (083).
- **ullage CU:** Depiction of residual volume in customer units. The unit can be selected or deselected in the "customer unit" function (056), and the maximum scale value in the "max. scale" function (057).
- **ullage DU:** Depiction of residual distance in the "distance unit" function (083).

Default value: level CU



Note!

The reference point for residual distance and/or residual volume is the "**full calibration (003)**".

Example of a volumetric measurement with the following parameters:

- Full calibration (003) = 20 m
- Silo volume (in measurement range selected) = 500 m<sup>3</sup>
- Current fill level = 4 m

#### 1. Measurement of current volume

level/volume (050) = level CU  
customer unit (056) = m<sup>3</sup>,  
max. scale (057) = 500

→ display (000) = 100 m<sup>3</sup>

#### 2. Measurement of residual volume

level/volume (050) = ullage CU  
customer unit (056) = m<sup>3</sup>,  
max. scale (057) = 500

→ display (000) = 400 m<sup>3</sup>

### 8.6.2 Customer unit (056)

```
customer unit    056
√%
  kg
  t
```

With this function, you can select the customer unit (CU). The following units are available for selection:

- percentage %
- weight: **kg, t**
- volume: **m<sup>3</sup>, ft<sup>3</sup>**
- length: **m, ft, in**

Default value: %

### 8.6.3 Max. scale (057)

```
max. scale      057
  100 %
```

With this function, you can define the maximum scale value (in the unit selected and the number of digits after the decimal point selected).

Range of values: 1 to 100000

Default value: 100



## 8.7 "display (06)" function group

### 8.7.1 Language (060)

```
language 060
√Deutsch
English
Français
```

Use this function to select the language of the display texts in the display:

- **Deutsch**
- **English**
- **Français**
- **ニホソゴ (Katakana, Japanese)**

Default value: English

### 8.7.2 Back to home (061)

```
back to home 061
100 s
time until jump back
home automatically
```

With this function, you specify the time after which the display returns to the measured value display (000).

Range of values: 3 to 9999 seconds

Default value: 100

### 8.7.3 Number of decimals (062)

```
no. of decimals 062
√x
x.x
x.xx
```

With this function, you select the number of digits after the decimal point for the measured value display (000) and for entry of several parameter values:

- **x:** No digit after the decimal point
- **x.x:** One digit after the decimal point
- **x.xx:** Two digits after the decimal point
- **x.xxx:** Three digits after the decimal point

Default value: x.xx

### 8.7.4 Format display (063)

```
format displ 063
√off
on
```

With this function, you activate a test for the LC display. All points on the display are activated for around 2 seconds.

- **off:** No display test
- **on:** Display test

Default value: off

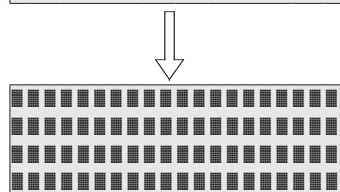

## 8.8 "diagnostics (07)" function group

### 8.8.1 Present error (070)

```
present error      070
simulation
activated
                    W621
```

The present error (e.g. "simulation activated"), its error code (e.g. 621) and the letter "W" for warning or "A" for alarm are shown in the display. If the error is a warning, only this is displayed. In the case of an alarm, this is also output via the "alarm" relay output, provided that this has been selected.



Note!

For the depiction of all error codes, please refer to chapter 10 "Troubleshooting".

### 8.8.2 Previous error (071)

```
previous error    071
minimum run down
length underflow
                    A440
```

The previous error, its error code and the letter "W" for warning or "A" for alarm are shown in the display.

For the depiction of all error codes, please refer to chapter 10 "Troubleshooting".

### 8.8.3 Clear errors (072)

```
clear errors      072
√keep
erase previous
erase present
```

With this function, you can delete the errors shown:

- **keep:** Errors are not deleted.
- **erase previous:** Previous error is deleted.
- **erase present:** Present error is deleted.
- **erase all:** All errors are deleted.

Default value: keep

### 8.8.4 Reset (073)

```
reset              073
                   0
for reset code
see manual
```

With this function, you can reset the Silopilot. All parameters are loaded with their default values.

Range of values: ■ 333 undertakes reset  
 ■ <>333 does not undertake reset



Note!

- A reset of the Silopilot must be followed at least by a basic setup!
- Take a note (if possible) of the parameters set so that the Silopilot functions required can be re-established after a reset! You will find suitable tables for noting all settings in the appendix.

### 8.8.5 Unlock parameter (074)

```
unlock parameter 074
                   100
for lock code
see manual
```

With this function, you can lock the parameter entries. No more values can then be entered in any part of the menu (exception: unlock parameter).

Range of values: ■ <>100 locks parameter entry  
 ■ 100 unlocks parameter entry

## 8.9 "system parameters (08)" function group

### 8.9.1 Tag number (080)

```
tag no.          080
Ratingen Silo 1
```

With this function, you can give the measuring point of the Silopilot a name of no more than 16 alpha-numerical digits.

Default value: \_\_\_\_\_

### 8.9.2 Protocol + software number (081)

```
Protocol+sw-no. 081
V01.00.00
```

With this function, you can display the protocol and software version of the Silopilot.

### 8.9.3 Serial number (082)

```
serial no.      082
1001
```

With this function, you can display the serial number of the Silopilot. You will also find the serial number on the name-plate.

### 8.9.4 Distance unit (083)

```
distance unit   083
√m
ft
in
```

With this function, you can enter the length unit of the Silopilot. This forms the basis for all display and entry values, with the exception of the customer unit (CU), provided that this has been selected.

- **m:** meter
- **ft:** feet
- **in:** inch

Default value: m

## 9 Manual mode

By selecting "**manual**" mode in the "**measurement type (020)**" function (see chapter 8.2), the Silopilot can be operated using the **+** and **-** keys on the device. Manual mode gives the user the opportunity to move the sensing weight slowly (e.g. for a tape change).



Warning!

When in manual mode, the upper limit switch and the loose band switch have no function!

Users must themselves ascertain the position in which the sensing weight is currently located.

In manual mode, the sensing weight can e.g. be lowered into an outlet worm (depending on the maximum tape length).

### 9.1 Operation



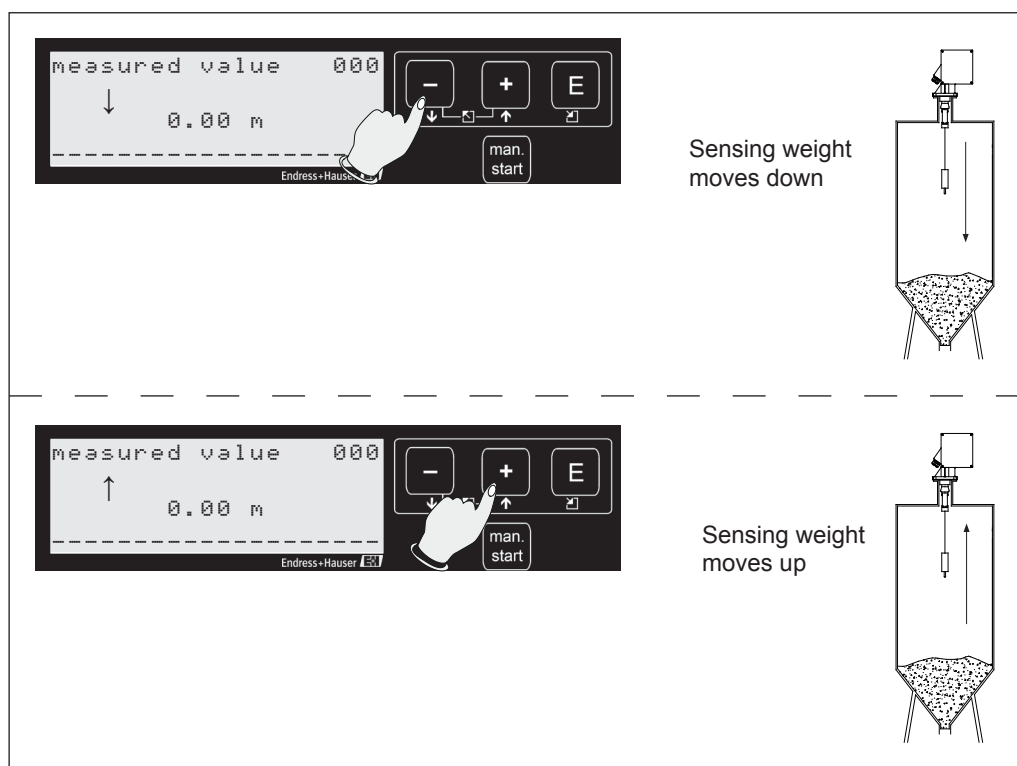

Once the manual mode has been selected, the "measured value (000)" function must be selected. Manual movements can now be undertaken using the sensing weight keys.



Manual operation

## 9.2 Display

If the Silopilot is in manual mode, a hand symbol appears on the display:

Symbol	Meaning
	- This symbol flashes when the device is in the "manual mode" type of measurement without a button being pressed.
	- This symbol flashes when the device is in the "manual mode" type of measurement and the  button is pressed. - The sensing weight moves down.
	- This symbol flashes when the device is in the "manual mode" type of measurement and the  button is pressed. - The sensing weight moves up.

In manual mode, the "measured value" (000) automatically shows the tape length run out. The value displayed depends on the distance unit (m, ft, in) selected in function 083 as well as the depiction of digits after the decimal point selected in function 062. Once work in manual mode has been completed, the measured value display is changed back to the form of depiction originally selected (e.g. fill level in technical units).



Note!

The last valid measured value remains saved internally, it is not overwritten in manual mode. The outputs still follow this (e.g. with a 50% fill level, 12 mA is still output for the current output).

## 10 Troubleshooting

### 10.1 Error messages

The Silopilot T FMM20 can display an error, which occurs during commissioning or measurement operation, in the following ways:

- by the error symbol in the "**measured value (000)**" function
- in the "diagnostics (07)" function group in the "**present error (070)**" function or in the "**previous error (071)**" function
- by means of relays, as long as the "**alarm**" option has been selected in the function(s) "**relay output 1 (014)**" and/or "**relay output 2 (01A)**" and/or optionally "**relay output 3 (01B)**" and/or "**relay output 4 (01C)**"
- via the current output characteristics programmed in the "**output on alarm (040)**" function

#### 10.1.1 Present error (070)

The present error is displayed in the "diagnostics (07)" function group in the "**present error (070)**" function.

```

present error      070
simulation
activated
                                W621
    
```

This display can be deleted in the "**clear errors (072)**" function.



Note!  
Only the error with the highest level priority is displayed.

#### 10.1.2 Previous error (071)



The previous error is displayed in the "diagnostics (07)" function group in the "**previous error (071)**" function.

```

previous error    071
motor current
consumption is
too low          A205
    
```

This display can be deleted in the "**clear errors (072)**" function.

### 10.2 Types of error

Type of error	Symbol	Meaning
Alarm (A)	 Permanent	- The relay with the programmed alarm function (see 10.1) drops out. - The current output takes on a value which has been defined by means of the " <b>output on alarm (040)</b> " and " <b>current range (033)</b> " functions.
Warning (W)	 Flashing	- Device continues to measure. - An error message is displayed.

### 10.3 Error messages

All possible errors, their error codes and their meaning and/or possible forms of rectification can be seen in the following tables:

Code	Cause	Remedy
A100	Checksum error in internal program memory	<ul style="list-style-type: none"> <li>- Reset</li> <li>- Avoid EMC problems</li> <li>- If the alarm is still present after a reset, contact service and/or replace the electronics</li> </ul>
A101	Check sum error in EEPROM 1	
A102	Check sum error in EEPROM 2	
A103	Initialization failed	
A106	Program download error (only for service technicians)	Repeat download and/or restart
W110	Default service parameters loaded	<ul style="list-style-type: none"> <li>- Warning that a reset has been undertaken</li> <li>- Goes out automatically with next entry</li> </ul>
W111	Default customer parameters loaded	
W112	Default input/output configuration loaded	
A120	Error during loading the service parameters	<ul style="list-style-type: none"> <li>- Reset</li> <li>- Avoid EMC problems</li> <li>- If the alarm is still present after a reset, contact service and/or replace the electronics</li> </ul>
A121	Error during loading the customer parameters	
A122	Error when loading the input/output configuration	
A123	Error during loading the last measured values	
A125	Error during loading the language string	
A130	Process of saving the service parameters has failed	<ul style="list-style-type: none"> <li>- Reset</li> <li>- Avoid EMC problems</li> <li>- If the alarm is still present after a reset, contact service and/or replace the electronics</li> </ul>
A131	Process of saving the customer parameters has failed	
A132	Process of saving the input/output configuration has failed	
A133	Process of saving the measured values has failed	
A200	Interface to motor controller defective	<ul style="list-style-type: none"> <li>- Reset</li> <li>- avoid excessive heating of the Silopilot</li> <li>- If the alarm is still present after a reset, contact service</li> </ul>
A201	Initialization of motor controller failed	
A202	Fatal motor error	
A203	Temperature inside the motor driver is too high	

Continuation of system error messages:

Code	Cause	Remedy
A205	Motor current consumption is too high	<ul style="list-style-type: none"> <li>- Reset</li> <li>- Avoid heating the Silopilot too much</li> <li>- If the alarm is still present after a reset, contact service and/or replace the electronics</li> </ul>
A206	Motor driver defective	<ul style="list-style-type: none"> <li>- Reset</li> <li>- If the alarm is still present after a reset, contact service and/or replace the electronics</li> </ul>
A220	Temperature is too high	<ul style="list-style-type: none"> <li>- Check mounting position (see chapter 4)</li> <li>- If the alarm is still present after a reset, contact service</li> </ul>
A330	Maximum time for a measurement exceeded	If the alarm is still present after several measurement processes, contact service
A340	Sensing weight or tape/rope is torn	<ul style="list-style-type: none"> <li>- Inspection of the sensing weight and measuring tape</li> <li>- If necessary, replace the sensing weight and/or measuring tape</li> </ul>
A350	Sensing weight is buried	<ul style="list-style-type: none"> <li>- Expose sensing weight by hand</li> <li>- Reset or briefly withdraw supply voltage (restart the device)</li> </ul>
A430	Tape-switch expected	Contact service and/or replace tape switch
A431	Limit-switch expected	Contact service
A440	Minimum move distance not reached	<ul style="list-style-type: none"> <li>- Check mounting situation</li> <li>- Remove the transport fixture</li> <li>- Observe minimum sensing weight move distance of 20 cm</li> </ul>
A450	Time for counting wheel pulses exceeded	<ul style="list-style-type: none"> <li>- Check the counting wheel</li> <li>- Reset</li> </ul>
A460	Counting wheel is slipping	<ul style="list-style-type: none"> <li>- If the alarm is still present after a several measurement processes, contact service</li> </ul>
A470	Measurement could not be started	<ul style="list-style-type: none"> <li>- Check the device for damage or blocking parts</li> </ul>
W621	Simulation activated	Deactivate simulation in function 026
A630	Maximum move distance exceeded	<ul style="list-style-type: none"> <li>- Check the tape switch</li> <li>- Check the installation situation</li> <li>- Use device with larger measurement range</li> </ul>
A650 W651	Below minimum security distance	<ul style="list-style-type: none"> <li>- Check the installation situation</li> <li>- Check the programming</li> </ul>
A660 W661	Safety distance underrun	
W681	Measurement range exceeded	
W700	Tape/rope change required	<ul style="list-style-type: none"> <li>- Check measuring tape/measuring rope, replace if necessary</li> <li>- Reset maintenance interval counter</li> </ul>



## 11 Maintenance

### 11.1 External cleaning

When externally cleaning the Silopilot, ensure that the cleaning agent used does not attack the housing surface and seals.

### 11.2 Cleaning dirty compartment

The cleaning periods depend on the properties of the bulk solid. If a lot of dust has accumulated, we would recommend blowing in small amounts of clean compressed air via the rinsing air connection (see chapter 4 "Installation").

### 11.3 Wiper check

The two wiper pieces in the wiper are worn to a greater or lesser extent depending on the abrasive nature of the product and then no longer sufficiently clean the measuring tape.

To check the wiper, you have to remove the Silopilot. To do so, please note chapter 4 "Installation". The following points should be checked:

- Check whether the taper and guide of the start piece are being dissected by the measuring tape. If there are deep gashes, there is a risk of the measuring tape jamming. Replace the end guide if necessary.
- Check whether both wiper plates are securely in contact with the measuring tape. Also replace the wiper plates if worn.
- Check whether the bellows are still in perfect condition. Replace if damaged.

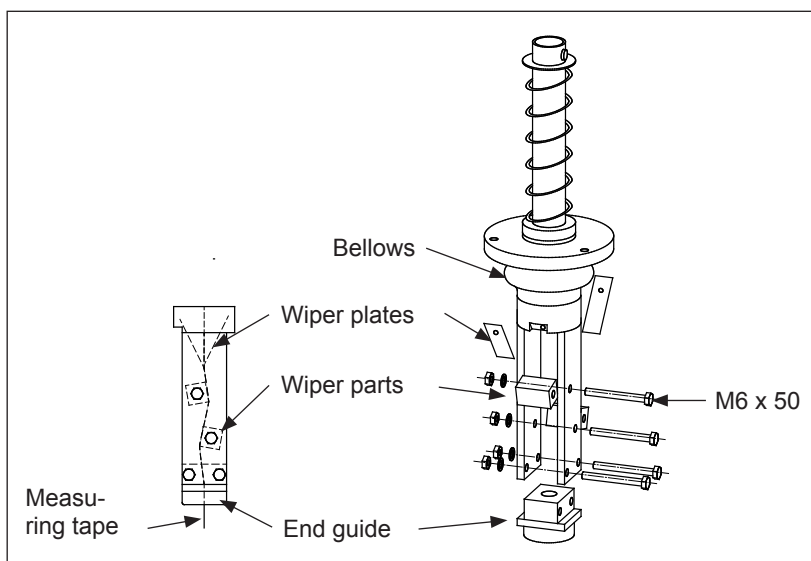

*Wiper check*



Note!

Please refer to chapter 12 "Repair" for details of how to dismantle the Silopilot.

## 11.4 Inspection of measuring tape

On the Silopilot, it is the measuring tape which is subject to the greatest mechanical load. It should therefore be checked as follows at regular intervals:

- If the visible part (Silopilot limit position) of the measuring tape is damaged, uncoil a section (measuring type "manual" (020)) until it looks perfect. Cut off the damaged part and re-mount the sensing weight.



Attention!

Do not cut off too much. Note the original length and the measurement range required (e.g. silo height).

- If the measuring tape is damaged on a longer part, replace the entire measuring tape. Tape spools of standard lengths can be supplied for this purpose.



Note!

Please refer to chapter 12 "Repair" for details of how to dismantle the Silopilot.

## 11.5 Dirty compartment check

Check the dirty compartment at regular intervals as follows:

- If the tape spool is severely corroded or damaged, replace it. Tape spools with standard lengths of measuring tape wound on can be supplied for this purpose.
- If the counting wheel is very sluggish to turn when the measuring tape is unwound or it is damaged, replace it.
- If the cover seals have deteriorated or are damaged, replace them.



Note!

Please refer to chapter 12 "Repair" for details of how to dismantle the Silopilot.

## 12 Repair

The Endress+Hauser repair concept ensures that the measuring devices have a modular structure and that repairs can be undertaken by the customer. Spare parts are each combined in useful kits.

All the spare part kits and their order numbers are listed in the spare parts section. These can be ordered from Endress+Hauser for repairs to the Silopilot. For more information on service and spare parts, please contact the Endress+Hauser service department.

### 12.1 Repairing Ex-certified devices

When repairing Ex-certified devices, the following must also be noted:

- Repairs to Ex-certified devices may only be undertaken by the Endress+Hauser service team.
- When replacing spare parts, only genuine parts from Endress+Hauser may be used.
- When ordering spare parts, please note the device designation on the nameplate. Parts may only be replaced with the same parts.
- Conversion of a certified device in a variant with different certification may only be undertaken by the Endress+Hauser service team.

### 12.2 Replacing components

Once a complete electronic or one PCB has been replaced, basic setup must be undertaken again. All parameters also have to be re-entered. We would therefore recommend the following procedure:

- Note down all settings. Tables appropriate for this purpose can be found in the appendix.
- After replacement, transfer all the settings noted.

#### 12.2.1 Tape change

When changing the tape, proceed as follows:

1. Move the sensing weight down a little (at least 5 cm) in the "manual (020)" mode so that the measuring tape is relieved.



Note!

When using larger special sensing weights, the weight must be lowered to an appropriate hatch (see chapter 4 "Installation").

2. Render the device voltage-free.
3. Remove and/or expose the Silopilot until the wiper and sensing weight are accessible.
4. Remove the sensing weight including the tape border.
5. Remove the tape guide.
6. Unscrew the four screws on the tape spool.
7. Carefully remove the tape spool and the unwound part from the device.
8. A new tape spool is then installed in reverse order.

Details of this can also be found in the exploded drawing on the next page.

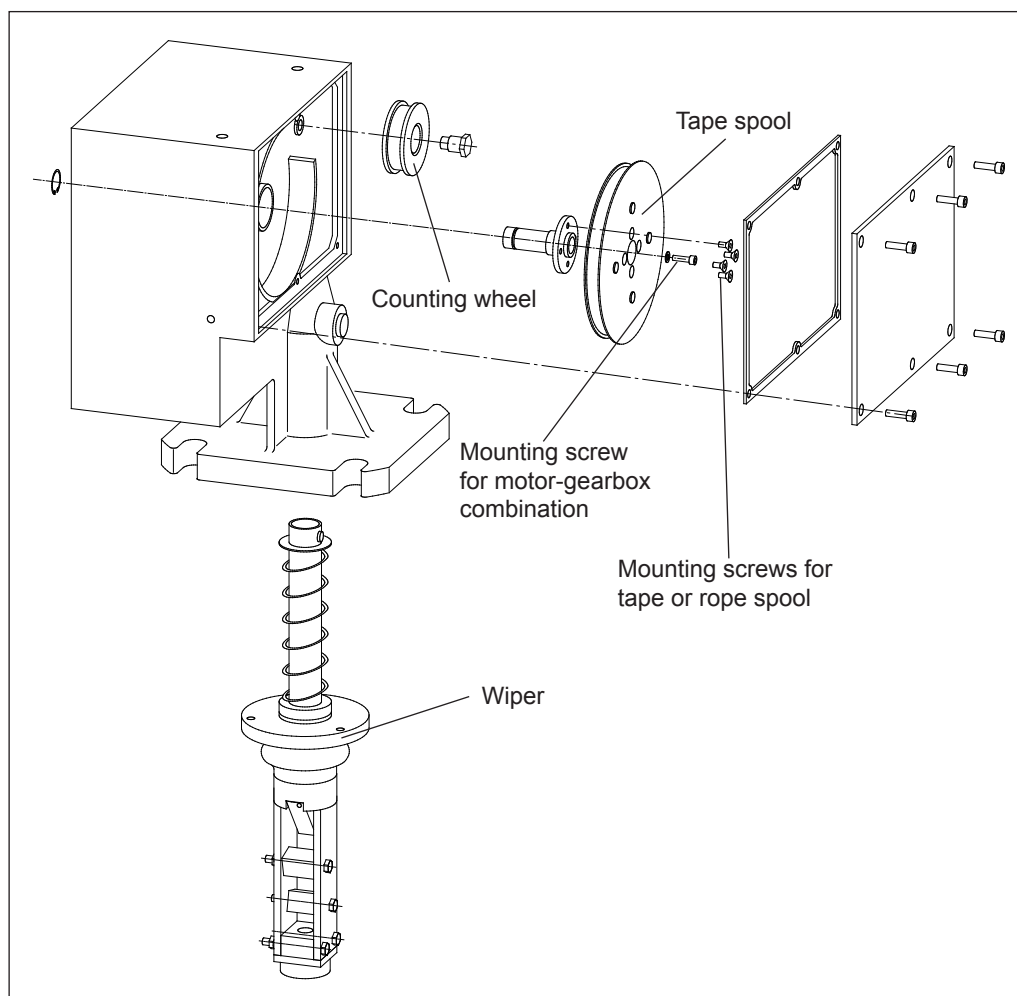

*Repair on dirty compartment side*

### 12.2.2 Replacing the wiper

You can also replace the wiper as soon as you have prepared the device as described under 12.2.1 "Tape change".

Unfasten the three M5 wiper screws. You can now take out the wiper.



Note!

When dismantling and/or installing, ensure that the measuring tape is positioned correctly in the wiper. The tape must not be turned in the dirty compartment. The dirty compartment cover should be opened during installation for this purpose.

### 12.2.3 Replacing the drive unit

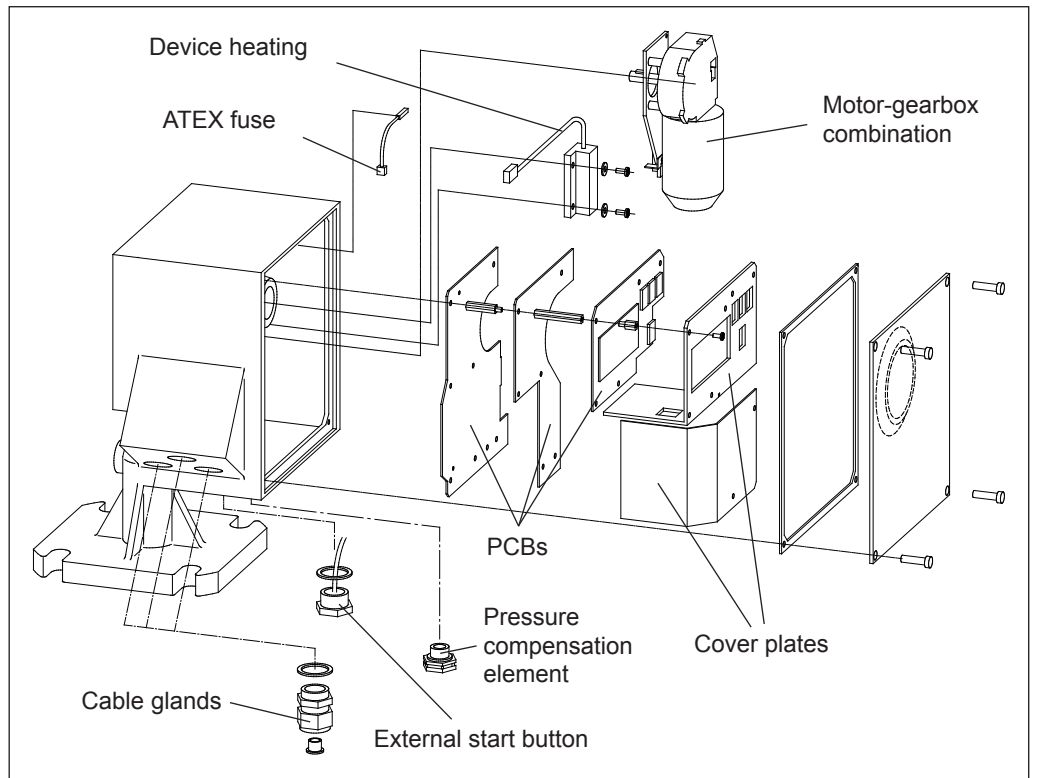

*Repair on electronics side*

To replace the drive unit, proceed as follows:

1. Move the sensing weight down a little in the "manual (020)" mode so that the measuring tape and therefore the drive shaft are relieved. Then fix the sensing weight or measuring tape in place.
2. Render the device voltage-free.
3. Unscrew the mounting screws on the cover plates and remove the plates.
4. The plug for the motor connector cable can be seen at the top right of the motor-gearbox combination, disconnect the plug.
5. Unscrew the mounting screw of the gearbox (see figure in chapter 12.2.1) on the dirty compartment side.
6. Carefully remove the top PCB (FMM20\_C), you can pull out the PCB for 3-4 cm. Put the PCB on the top of the Silopilot housing.
7. Carefully hang out the return spring (see the following figure).
8. The motor-gearbox combination can now be removed carefully.
9. A new motor-gearbox combination is installed in reverse order.

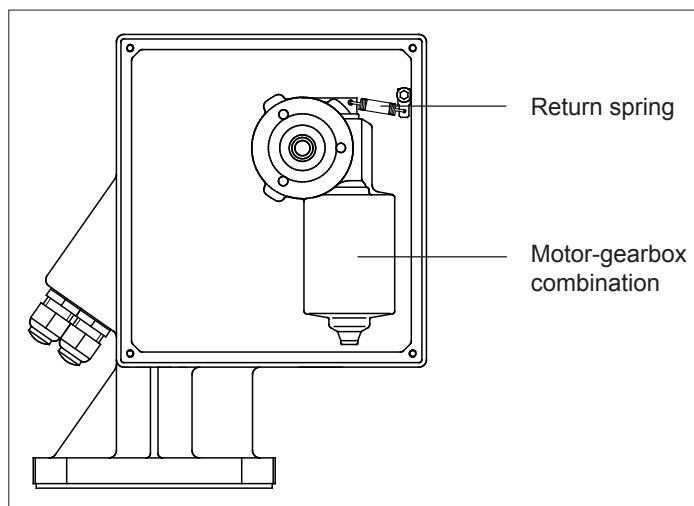

*Transmission motor with return spring*



Attention!

You need to install the mounting screw of the gearbox again with a copper washer (ATEX).

### 12.2.4 Replacing the electronic

The single PCBs of the electronic should only be replaced by a specialist. A precise description of replacement process is enclosed with every new piece of PCB. A precise description of the process is not therefore given at this point.

Observe the following points when carrying out a replacement:

- When working with electronic components, ensure that you have sufficient ESD protection (protection against electrostatic discharge).
- Only use the PCBs permitted for the device type when replacing parts.  
Using incorrect electronic parts may result in the device being destroyed or its Ex-certification being lost.

After you replaced the PCB "FMM20\_C", basic setup must be undertaken again. All parameters also have to be re-entered. We would therefore recommend the following procedure:

- Note down all settings. Tables appropriate for this purpose can be found in the appendix.
- After replacement, transfer all the settings noted.

### 12.3 Returns

The following measures must be taken before returning a measuring device to Endress+Hauser, e.g. for repair:

- Remove all residue from measuring materials which may be stuck onto the device. Pay particular attention to seal grooves and scoring in which residue from measuring materials may stick. This is of particular importance if the measuring material poses a risk to health, e.g. is flammable, poisonous, corrosive, carcinogenic, etc.
- Always enclose a fully completed "**Declaration of Contamination**" with the device (a template of this declaration can be found in the appendix). Endress+Hauser can only check or repair any devices returned if this is done.

Also specify:

- The chemical and physical characteristics of the measuring material
- A description of the application
- A description of the error which has occurred (if necessary, specify the error code)
- Operating period of the device

## 12.4 Spare parts



Note!

Please refer to the instruction leaflet supplied or these Operating Instructions for installation instructions.

### 12.4.1 Electronics

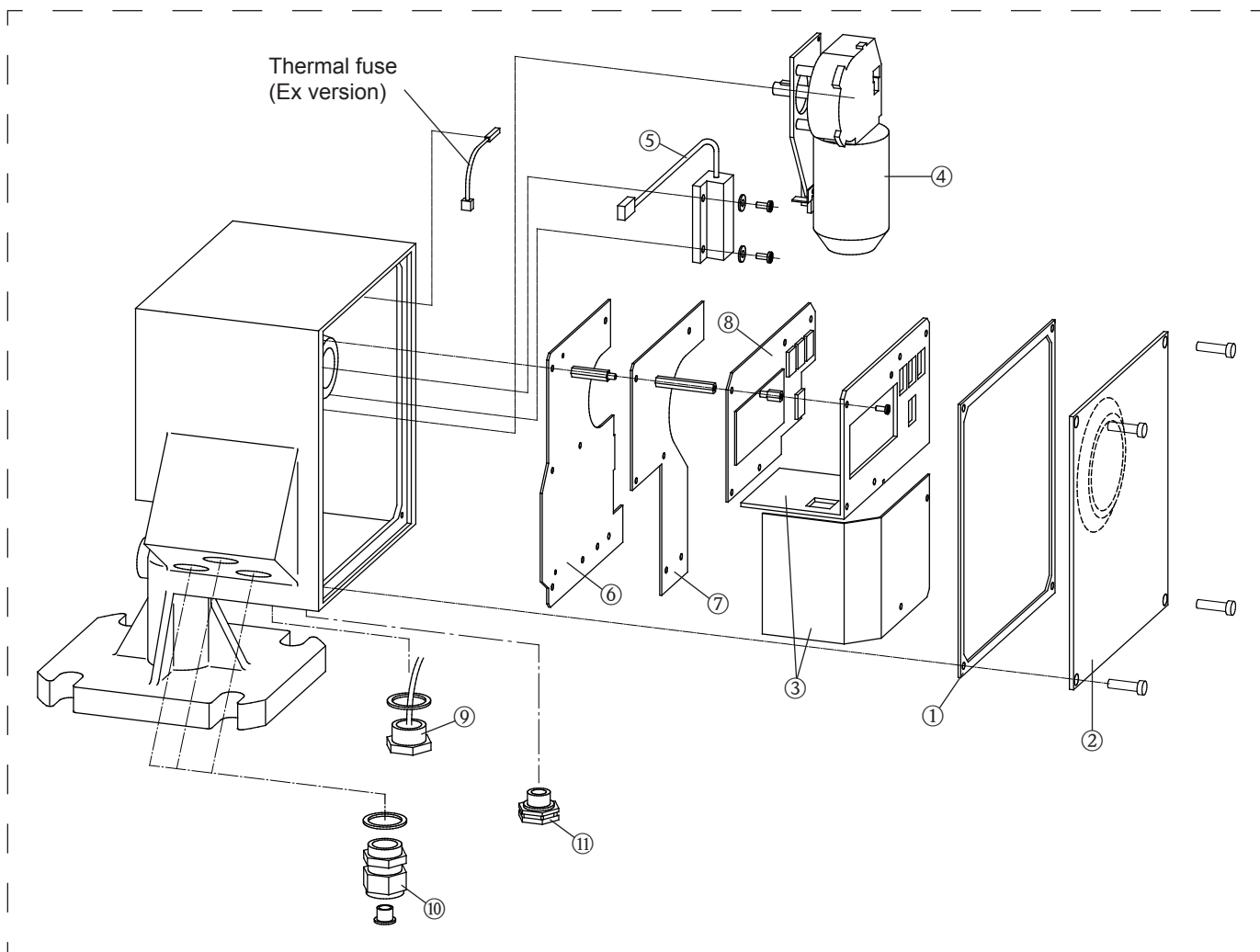

#### 1 Cover seal for electronics compartment

71031652 Seal, non-Ex version (including cover seal for dirty compartment)

71031653 Seal, Ex version (including cover seal for dirty compartment)

#### 2 Housing cover (including cover seal)

71031695 Housing cover, not coated, no sight glass

71031696 Housing cover, coated, no sight glass, extended resistance to climatic changes

71031697 Housing cover, not coated, with sight glass

71031698 Housing cover, coated, with sight glass, extended resistance to climatic changes

#### 3 Electronic cover

71031706 Cover (2-part), steel plate with inscription

71031707 Cover (2-part), steel plate with inscription, extended resistance to climatic changes

#### 4 Motor-gearbox combination

71031654 24 VDC, 150 N

71031655 24 VDC, 150 N, extended resistance to climatic changes

**5 Device heating**

- 71031795 Device heating, 115/230 VAC
- 71031709 Device heating, 24 VDC

**6 PCB FMM20\_M**

- 71031711 90-253 VAC, 2 relays, not an Ex version, without heating connection
- 71031751 same as 71031711 + extended resistance to climatic changes
- 71031747 90-253 VAC, 2 relays, not an Ex version, with heating connection
- 71031713 90-253 VAC, 4 relays, not an Ex version, without heating connection
- 71031752 same as 71031713 + extended resistance to climatic changes
- 71031748 90-253 VAC, 4 relays, not an Ex version, with heating connection
- 71031745 90-253 VAC, 2 relays, Ex version, without heating connection
- 71031753 same as 71031745 + extended resistance to climatic changes
- 71031749 90-253 VAC, 2 relays, Ex version, with heating connection
- 71031746 90-253 VAC, 4 relays, Ex version, without heating connection
- 71001754 same as 71031746 + extended resistance to climatic changes
- 71001750 90-253 VAC, 4 relays, Ex version, with heating connection
  
- 71031767 20-28 VDC, 2 relays, not an Ex version, without heating connection
- 71031775 same as 71031767 + extended resistance to climatic changes
- 71031771 20-28 VDC, 2 relays, not an Ex version, with heating connection
- 71031768 20-28 VDC, 4 relays, not an Ex version, without heating connection
- 71031776 same as 71031768 + extended resistance to climatic changes
- 71031772 20-28 VDC, 4 relays, not an Ex version, with heating connection
- 71031769 20-28 VDC, 2 relays, Ex version, without heating connection
- 71031777 same as 71031769 + extended resistance to climatic changes
- 71031773 20-28 VDC, 2 relays, Ex version, with heating connection
- 71031770 20-28 VDC, 4 relays, Ex version, without heating connection
- 71001778 same as 71031770 + extended resistance to climatic changes
- 71001774 20-28 VDC, 4 relays, Ex version, with heating connection

**7 PCB FMM20\_N**

- 71031779 PCB power supply 90-253 VAC
- 71031780 PCB power supply 90-253 VAC + extended resistance to climatic changes
- 71031781 PCB power supply 20-28 VDC
- 71031782 PCB power supply 20-28 VAC + extended resistance to climatic changes

**8 PCB FMM20\_C**

- 71031783 PCB processor
- 71031784 PCB processor + extended resistance to climatic changes

**9 External start button**

- 71031710 Start button, external, stainless steel version

**10 Cable glands**

- 71031689 Cable gland, 3 pieces, without Ex certification
- 71031694 Cable gland, 3 pieces, with Ex certification

**11 Pressure compensation element**

- 71031705 Pressure compensation element, plastic, not an Ex version
- 71032447 Pressure compensation element, stainless steel, Ex version



### 12.3.2 Mechanics

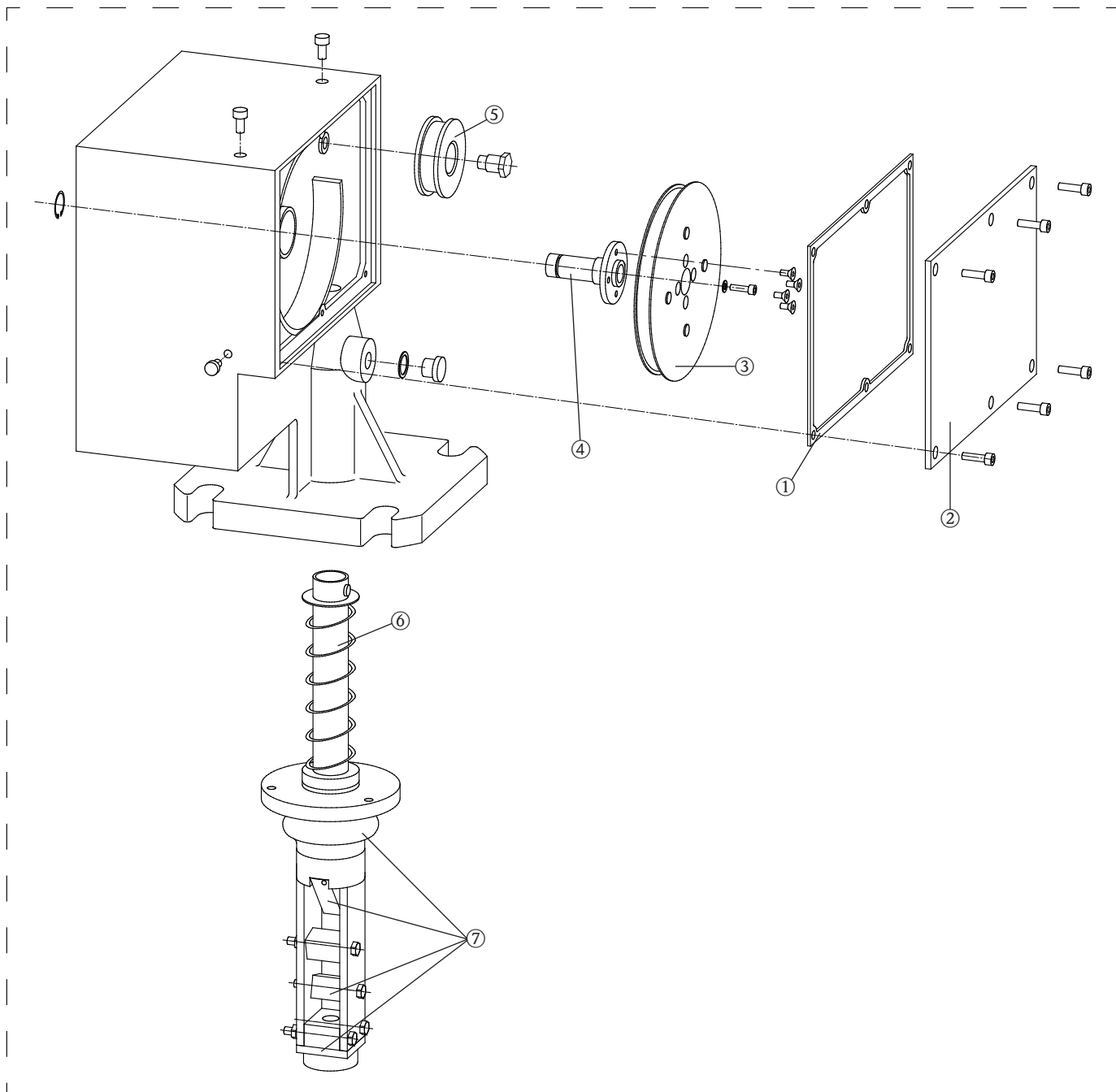

- 1 Cover seal for dirty compartment**
  - 71031652 Seal, non-Ex version (including cover seal for electronics compartment)
  - 71031653 Seal, Ex version (including cover seal for electronics compartment)
- 2 Housing cover (including cover seal item 1)**
  - 71031699 Housing cover, not coated
  - 71031700 Housing cover, coated
- 3 Tape spool**
  - 71031658 Spool with measuring tape, 15 m
  - 71031659 Spool with measuring tape, 15 m + extended resistance to climatic changes
  - 71031671 Spool with measuring tape, 32 m
  - 71031672 Spool with measuring tape, 32 m + extended resistance to climatic changes
- 4 Spare parts kit for drive shaft**
  - 71031649 Drive shaft including ball bearing, shaft seal and mounting material

**5 Counting wheel, complete**

- 71031650 Counting wheel for tape version, fully mounted
- 71031651 Counting wheel for rope version, fully mounted

**6 Wiper, complete**

- 71031621 Wiper 230 mm, aluminum/steel, process temp. of up to +70°C
- 71031622 Wiper 230 mm, stainless steel, process temp. of up to +70°C
- 71031623 Wiper 230 mm, aluminum/steel, process temp. of up to +150°C
- 71031624 Wiper 230 mm, stainless steel, process temp. of up to +150°C
- 71031625 Wiper 500 mm, aluminum/steel, process temp. of up to +70°C
- 71031626 Wiper 500 mm, stainless steel, process temp. of up to +70°C
- 71031627 Wiper 500 mm, aluminum/steel, process temp. of up to +150°C
- 71031628 Wiper 500 mm, stainless steel, process temp. of up to +150°C
- 71031629 Wiper 1000 mm, aluminum/steel, process temp. of up to +70°C
- 71031630 Wiper 1000 mm, stainless steel, process temp. of up to +70°C
- 71031631 Wiper 1000 mm, aluminum/steel, process temp. of up to +150°C
- 71031632 Wiper 1000 mm, stainless steel, process temp. of up to +150°C

**7 Spare parts kit for wiper**

- 52028080 Spare parts kit for wiper, process temperature of up to +70°C
- 52028081 Spare parts kit for wiper, process temperature of up to +150°C

### 12.3.3 Sensing weights

For a description of the sensing weights and their possible applications, please refer to chapter 3 "Sensing weights".

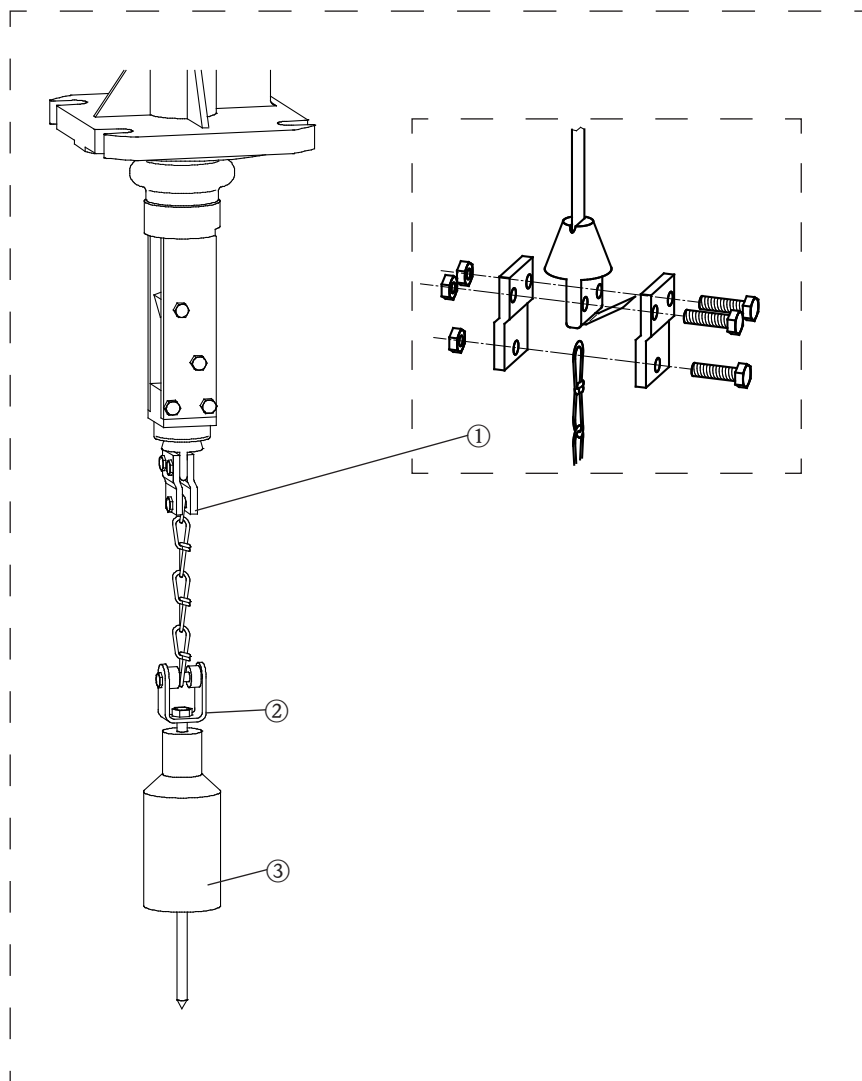

**1 Sensing weight mounting, complete**

- 52028088 Tape border, rotating bush, chain, mounting material, aluminum/steel
- 52028089 Tape border, rotating bush, chain, mounting material, stainless steel

**2 Rotating bush, complete**

- 52028100 Rotating bush, mounting material, steel
- 52028101 Rotating bush, mounting material, stainless steel

**3 Sensing weight, including rotating bush item 2**

- 71031620 Plastic
- 71031615 Steel
- 71031616 Stainless steel
- 71031617 Steel + umbrella
- 71031618 Stainless steel + umbrella
- 71031619 Medium bag

## 13 Accessories

### 13.1 Protective hood

A protective hood is available for outdoor installation of the Silopilot T FMM20.



Note!

You will need a free height of at least 240 mm above the Silopilot for installing and/or dismantling the protective hood.

#### 13.1.1 Stainless steel protective hood

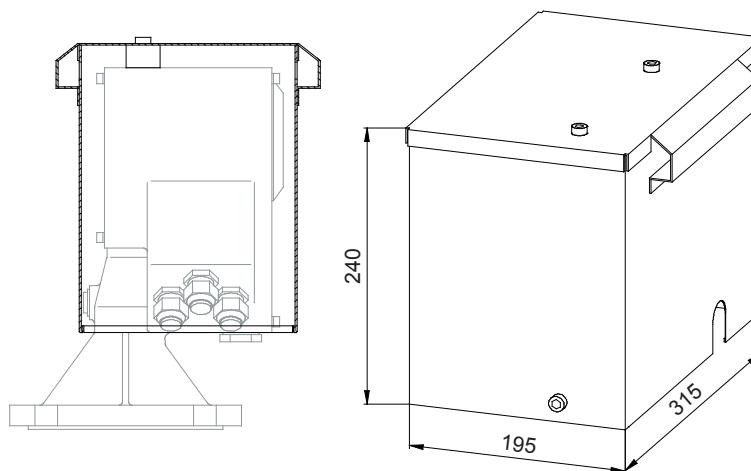

- Order no.: 71028956
- Material: stainless steel 304 (1.4301)
- Weight: 4.2 kg
- The delivery includes suitable mounting screws.

#### 13.1.2 Aluminium protective hood

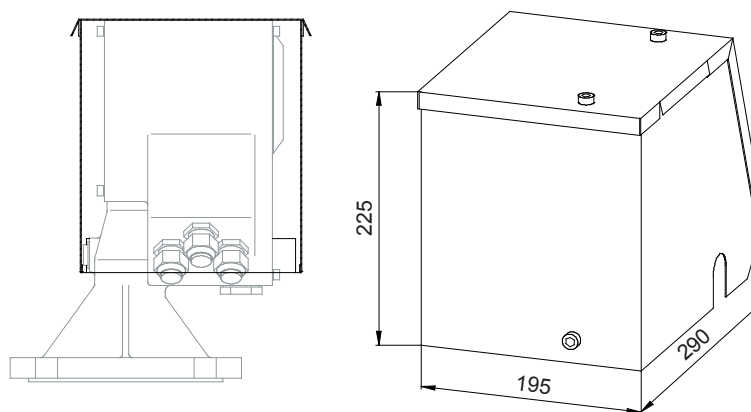

- Order no.: 71075962
- Material: aluminium
- Weight: 0.7 kg
- The delivery includes suitable mounting screws.

## 14 Technical data

### 14.1 Input values

Measurement parameter The distance between Silopilot (device flange) and product surface is measured.

The Silopilot can calculate the following values from this:

- Fill level in optional units or
- Volume in optional units

Measurement range

The maximum measurement range is calculated from the type code:

- Silopilot T FMM20 - \*\*1\*/-\*\*4\*: 15 m
- Silopilot T FMM20 - \*\*2\*/-\*\*5\*: 32 m

Block distance

The block distance is dependent on the wiper used and the sensing weight:

Sensing weight	Wiper 230 mm	Wiper 500 mm	Wiper 1000 mm
B, C, D, E	0.72 m	1.02 m	1.52 m
G	1.22 m	1.52 m	2.02 m
N	0.72 m	1.02 m	1.52 m

Input signal

- 2 signal inputs (start measurement, lock)
  - Active: 12 to 24 VDC
  - Passive: switching contact, max. 5 mW
  - galvanically isolated from the supply voltage and the signal outputs
  - Start pulse length: min. 200 ms

### 14.2 Output values

Output signal

- 0 - 20 mA / 4 - 20 mA current output
  - Active
  - Max. load: 600 Ω
- 2 relay outputs (max. 4 relays)
  - Contact load bearing capacity: 250 VAC, 6 A
  - Contact material: silver-cadmium-oxide, with gold flashings
- Optoelectronic coupler output (only for devices with 4 relays)
  - max. 30 VDC
  - max. 10 mA
- Output signals are galvanically isolated from each other, from the supply voltage and from the input signals.

Failure signal

- Error symbol, error code and description in plain text on the on-site display
- Current output, can be configured:
  - MIN (0/3.6 mA)
  - MAX (22 mA)
  - Last value is retained
  - Optional value (0 to 22 mA) is output
- Relay outputs (alarm function)

### 14.3 Accuracy

- Measurement error
- ± 2.5 cm (independent of measurement range selected)

### 14.4 Min. time for one measurement cycle

Measurement cycle

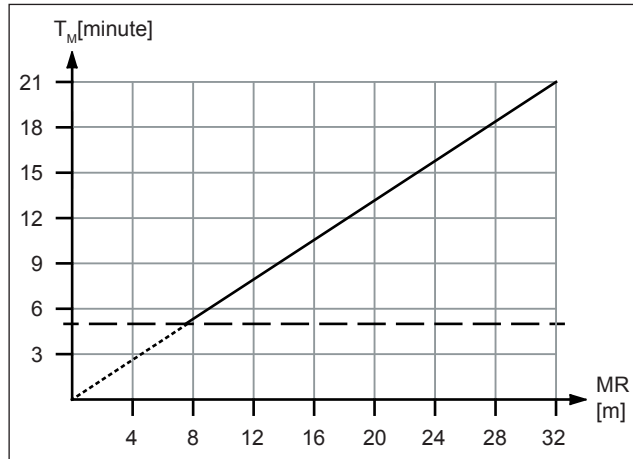

We recommend not to go below a time of 5 minutes for one measuring cycle, even with measuring ranges below 8 m.

### 14.5 Run-off speed

- Run-off speed
- 0.21 m/s (average speed)

### 14.6 Power supply

- Supply voltage
- Silopilot T FMM20 - \*\*\*\*1\*: 90 - 253 VAC, 50/60 Hz
  - Silopilot T FMM20 - \*\*\*\*3\*: 20 - 28 VDC

- Power consumption
- AC version:
    - approx. 150 VA (device without heater)
    - approx. 170 VA (device with optional heater)
  - DC version:
    - approx. 150 VA (device without heater)
    - approx. 170 VA (device with optional heater)

Note!

The maximum switch-on current of the DC version with optional heater will be 10 A (≤ 2 s).

- Cable entry
- M20 x 1.5
  - Cable gland (3 pieces):
    - Material: Plastic
    - Color: gray (or black for Ex version)

---

## 14.7 Environmental conditions

---

- Ambient temperature
- Silopilot T FMM20 - \*\*\*\*\*D\*/-\*\*\*\*\*F\*: -20°C to +60°C
  - Silopilot T FMM20 - \*\*\*\*\*E\*:
    - Non-hazardous area: -40°C to +60°C
    - Hazardous area: -35°C to +60°C

When operating outdoors with high levels of direct sunlight, the protective hood (available as an accessory) should be used.

Storage temperature -40°C to +60°C

- Type of protection
- With closed housing: IP 67
  - With closed housing and when using the external start button: IP 65
  - With open housing: IP 20

- Electromagnetic compatibility (EMC)
- Interference emission in accordance with EN 61326, class B operating equipment
  - Interference immunity in accordance with EN 61326, Appendix A (industrial sector)
  - Normal installation cable is sufficient for the wiring.

---

## 14.8 Process conditions

---

- Process temperature
- Silopilot T FMM20 - \*\*\*\*\*1\*: -20°C to +70°C
  - Silopilot T FMM20 - \*\*\*\*\*2\*: -20°C to +150°C (non-hazardous area)
- Process pressure
- 0.8 to 1.1 bar absolute

## 15 Appendix

### 15.1 Basic settings

Empty calibration (001)	Block distance (002)	Full calibration (003)
Default value: length of measu- ring tape	Default value: 0.72 m	Default: Empty calibration - 0.72 m

### 15.2 Measurement parameter settings

Measurement type (020)	Time interval (021)	Time unit (022)	Normal or short (023)
Default: Single cycle	Default: 1 h	Default: h	Default: Normal
Service interval (024)	Simulation (026)		
Default: 45000	Default value: Sim. off		

### 15.3 Output settings

Relay output 1 (014)	Relay output 2 (01A)	Relay output 3 (01B)	Relay output 4 (01C)
Default: Alarm	Default: Service interval	Default: Measuring	Default: Top position
Pulse value (015)	Counting pulse (016)	Reset pulse (019)	
Default: 1	Default: 50 ms	Default: 300 ms	



### 15.4 Input settings

Input 1 (010)	Input 2 (012)
Default: Not used	Default: Not used

### 15.5 Safety settings

Output on alarm (040)	Output on alarm (041)	Safety distance (042)	Security distance (043)
Default: MIN (0/3.6 mA)	Default: 3.6 mA	Default value: 0.00 m	Default value: 0.00 m
in security dist. (044)	in safety dist. (045)		
Default value: Warning	Default value: Alarm		

### 15.6 Display settings

Language (060)	Back to home (061)	No. of decimal (062)
Default: English	Default: 100 s	Default: x.xx

### 15.7 Other settings

Current range (033)	Tag number (080)	Distance unit (083)
Default: 4-20 mA	Default: -----	Default: m

### 15.8 Operating menu

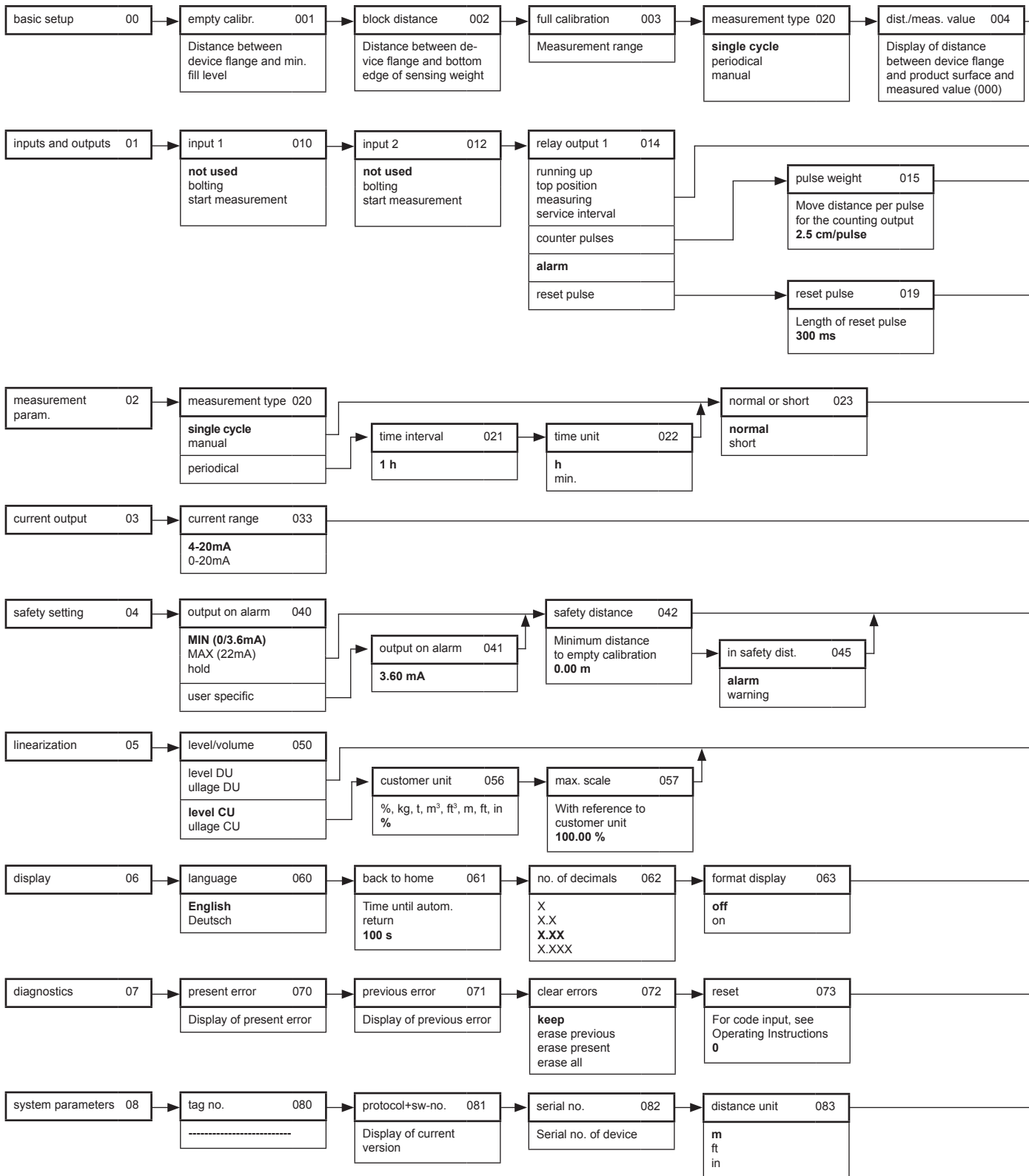

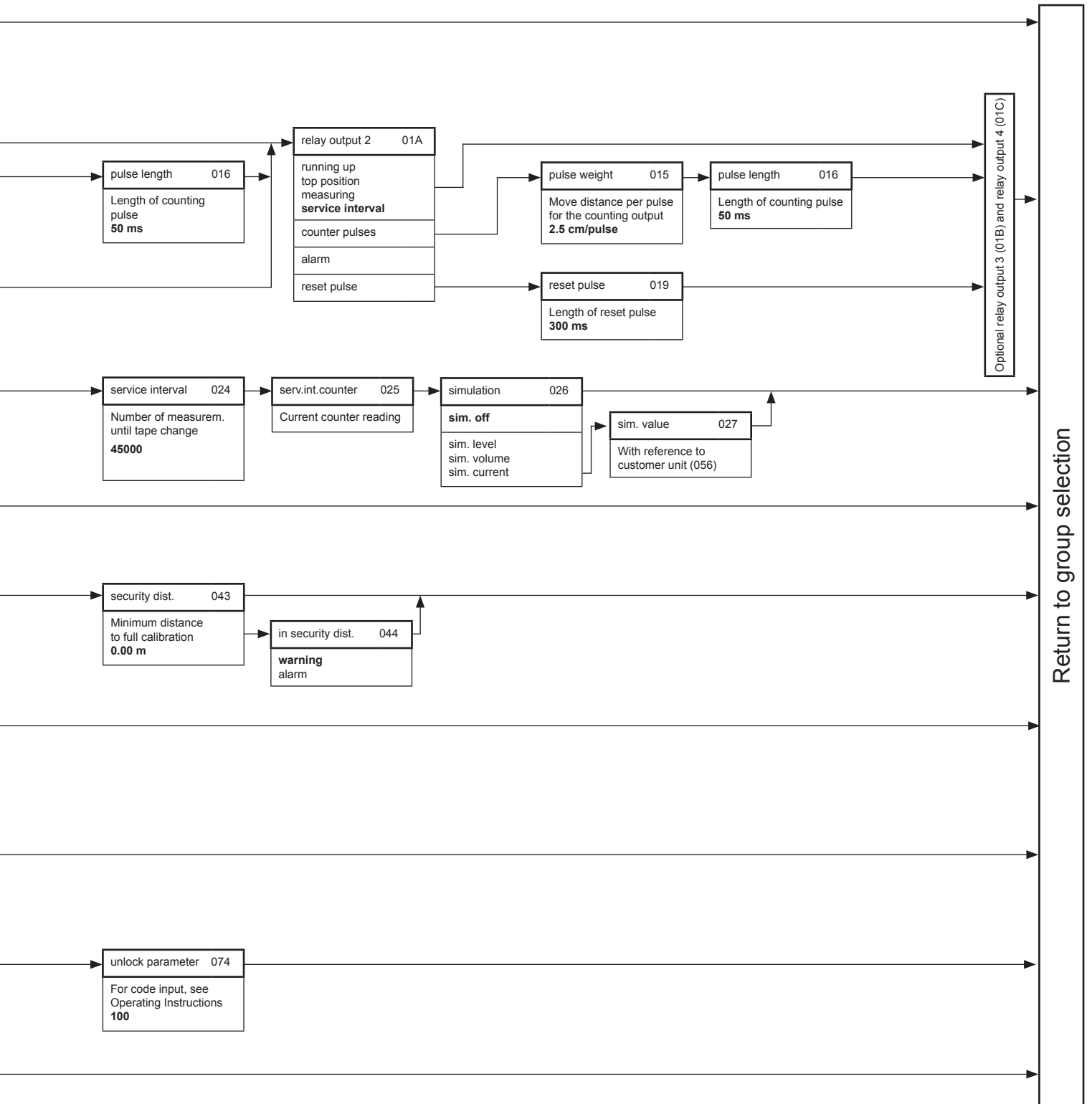

## 15.9 Software history

<b>Software version</b>	<b>Changes to software</b>	<b>Documentation Changes/Additions</b>
V 01.00.00	Original software	
V 01.01.00	Software expansion: New functionalities	BA334F/97/en/11.06: • Add function 045 "in safety dist."
V 01.01.01	Software expansion: Enhanced functionalities	• Optimized start-up
V 01.01.02	Software expansion: New functionalities	• Japanese language
V 01.01.03	Software expansion: Enhanced functionalities	• Optimized error handling

### 15.10 Declaration of contamination



## Declaration of Hazardous Material and De-Contamination Erklärung zur Kontamination und Reinigung

**RA No.**

Please reference the Return Authorization Number (RA#), obtained from Endress+Hauser, on all paperwork and mark the RA# clearly on the outside of the box. If this procedure is not followed, it may result in the refusal of the package at our facility.  
Bitte geben Sie die von E+H mitgeteilte Rücklieferungsnummer (RA#) auf allen Lieferpapieren an und vermerken Sie diese auch außen auf der Verpackung. Nichtbeachtung dieser Anweisung führt zur Ablehnung ihrer Lieferung.

Because of legal regulations and for the safety of our employees and operating equipment, we need the "Declaration of Hazardous Material and De-Contamination", with your signature, before your order can be handled. Please make absolutely sure to attach it to the outside of the packaging.

Aufgrund der gesetzlichen Vorschriften und zum Schutz unserer Mitarbeiter und Betriebseinrichtungen, benötigen wir die unterschriebene "Erklärung zur Kontamination und Reinigung", bevor Ihr Auftrag bearbeitet werden kann. Bringen Sie diese unbedingt außen an der Verpackung an.

**Type of instrument / sensor**  
Geräte-/Sensortyp \_\_\_\_\_

**Serial number**  
Seriennummer \_\_\_\_\_

**Used as SIL device in a Safety Instrumented System / Einsatz als SIL Gerät in Schutzeinrichtungen**

**Process data/ Prozessdaten**  
Temperature / Temperatur \_\_\_\_\_ [°F] \_\_\_\_\_ [°C]    Pressure / Druck \_\_\_\_\_ [psi] \_\_\_\_\_ [ Pa ]  
Conductivity / Leitfähigkeit \_\_\_\_\_ [µS/cm]    Viscosity / Viskosität \_\_\_\_\_ [cp] \_\_\_\_\_ [mm<sup>2</sup>/s]

**Medium and warnings**  
Warnhinweise zum Medium



	Medium /concentration Medium /Konzentration	Identification CAS No.	flammable entzündlich	toxic giftig	corrosive ätzend	harmful/ irritant gesundheits- schädlich/ reizend	other * sonstiges*	harmless unbedenklich
Process medium Medium im Prozess								
Medium for process cleaning Medium zur Prozessreinigung								
Returned part cleaned with Medium zur Endreinigung								

\* explosive; oxidising; dangerous for the environment; biological risk; radioactive  
\* explosiv; brandfördernd; umweltgefährlich; biogefährlich; radioaktiv

Please tick should one of the above be applicable, include safety data sheet and, if necessary, special handling instructions.  
Zutreffendes ankreuzen; trifft einer der Warnhinweise zu, Sicherheitsdatenblatt und ggf. spezielle Handhabungsvorschriften beilegen.

**Description of failure / Fehlerbeschreibung** \_\_\_\_\_  
\_\_\_\_\_

**Company data / Angaben zum Absender**

Company / Firma _____	Phone number of contact person / Telefon-Nr. Ansprechpartner: _____
Address / Adresse _____	Fax / E-Mail _____
_____	Your order No. / Ihre Auftragsnr. _____

"We hereby certify that this declaration is filled out truthfully and completely to the best of our knowledge. We further certify that the returned parts have been carefully cleaned. To the best of our knowledge they are free of any residues in dangerous quantities."

"Wir bestätigen, die vorliegende Erklärung nach unserem besten Wissen wahrheitsgetreu und vollständig ausgefüllt zu haben. Wir bestätigen weiter, dass die zurückgesandten Teile sorgfältig gereinigt wurden und nach unserem besten Wissen frei von Rückständen in gefahrbringender Menge sind."

■ (place, date / Ort, Datum)

Name, dept./Abt. (please print / bitte Druckschrift)

Signature / Unterschrift



## Index

### A

ATEX ..... 4, 5, 9, 51

### B

Basic setup ..... 27, 29  
 Block distance ..... 27, 29  
 Buttons ..... 23

### C

Certificates and approvals ..... 9  
 Commissioning ..... 26  
 Current output ..... 20, 37  
 Current range ..... 37  
 Customer unit ..... 40

### D

Description of device functions ..... 29  
 Diagnostics ..... 42  
 Dimensions ..... 13  
 Display ..... 41, 45  
 Display symbols ..... 23  
 Distance unit ..... 43

### E

Electrical connection ..... 18  
 Empty calibration ..... 27, 29  
 Environmental conditions ..... 63  
 Error ..... 42, 46  
 Error messages ..... 47  
 Explanation on contamination ..... 70

### F

Full calibration ..... 28, 29

### H

Hardware locking ..... 25

### I

Identification ..... 7  
 Inputs and outputs ..... 31  
 Installation ..... 4, 5, 12, 15

### L

Language ..... 41  
 Linearization ..... 40

### M

Maintenance ..... 49  
 Manual mode ..... 44  
 Max. scale ..... 40  
 Measurement cycle ..... 62  
 Measurement parameters ..... 33  
 Measurement type ..... 28, 33

### N

Nameplate ..... 9  
 Number of decimals ..... 41

### O

Operating menu ..... 68  
 Operation ..... 22  
 Optocoupler output ..... 21, 61  
 Ordering information ..... 7  
 Output on alarm ..... 38

### P

Potential matching ..... 18  
 Process conditions ..... 63  
 Protective hood ..... 60  
 Pulse length ..... 32  
 Pulse value ..... 32

### R

Relay outputs ..... 20, 31, 61  
 Repair ..... 51  
 Reset ..... 42  
 Reset pulse ..... 32

### S

Safety distance ..... 29, 38  
 Safety instructions ..... 4  
 Safety settings ..... 38  
 Security distance ..... 29, 38  
 Sensing weights ..... 10  
 Service interval ..... 34  
 Signal inputs ..... 21, 31, 61  
 Simulation ..... 35  
 Software locking ..... 25  
 Spare parts ..... 55  
 Supply voltage ..... 20, 62  
 System parameters ..... 43

### T

Technical data ..... 61  
 Terminal assignment ..... 19  
 Troubleshooting ..... 46

### U

Unlock parameter ..... 42

### W

Wiring ..... 18

[www.endress.com/worldwide](http://www.endress.com/worldwide)

---

**Endress+Hauser**   
People for Process Automation