

## Important Notice

### ⚠ CAUTION

Electrical shock could cause death or serious injury. If the sensor is installed in a high voltage environment and a fault or installation error occurs, high voltage may be present on the connection terminals or the probe itself.

Safe and secure operation of the temperature sensor can only be guaranteed if the operating instructions of the used transmitters and all included safety notes are read, understood and followed. For Endress+Hauser temperature transmitters see enclosed CD-ROM.

### Correct use

The manufacturer cannot be held responsible for damage caused by misuse of the unit. The installation conditions and connection values indicated in the operating instructions must be followed!

## Installation Guidelines and Safety instructions

1. Install the unit according to the relevant NEC Code and local regulations.
2. Avoid any spark due to impact, friction and installation. Anti-sparking wrenches should be utilized.
3. The temperature sensor should be connected to the power supply or other external circuit using the appropriate cable glands and wire entries.
4. For ambient temperature higher than 158 °F, suitable cables, conduit and conductors must be used. Only use approved wire entries.
5. When utilized in dust atmospheres, the connection between the housing, fittings and thermowell should provide a minimum degree of Ingress Protection. Liquid/gas sealants should be used. Local regulations need to be respected.

### ⚠ CAUTION

Do not disconnect equipment unless power has been switched off or the area is not hazardous.

The accessories for pipe connections and the appropriate gaskets and sealing rings are not supplied with the sensors. These are the customer's responsibility. Depending on temperature and pressure operating conditions, the gaskets, the sealing and the applicable torques must be selected by the user. For further information regarding connections, please refer to the corresponding Standards.

## Installation and operation

The unit is constructed using the most up to date production equipment and complies with the safety requirements of the local guidelines. However, if it is installed incorrectly or misused, certain application dangers can occur. Installation, wiring and maintenance of the unit must only be completed by trained, skilled personnel who are authorized to do so by the plant operator. The plant operator must make sure that the measurement system has been correctly wired to the connection schematics. Procedures indicated in these instructions must be followed.

## Returns

Please follow the Return Authorization Policy which is attached with this manual.

## Safety pictograms and symbols



Notes draw attention to activities or procedures that can have a direct influence on operation or trigger an unforeseen device reaction if they are not carried out properly.

### ⚠ CAUTION

Cautions draw attention to activities or procedures that can lead to persons being seriously injured, to safety risks or to the destruction of the device if they are not carried out properly.

*Though the information provided herein is believed to be accurate, be advised that the information contained herein is NOT a guarantee of satisfactory results. Specifically, this information is neither a warranty nor guarantee, expressed or implied, regarding performance; merchantability, fitness, or other matter with respect to the products; and recommendation for the use of the product/process information in conflict with any patent. Please note that Endress+Hauser reserves the right to change and/or improve the product design and specifications without notice.*

## Compact instructions Sanitary RTD Temperature sensor TH17

### Measuring System

Sanitary RTD assembly with connection head TH17 for food and dairy applications.

The single element RTD is specifically

designed for use in process temperature

range -58 °F (-50 to 200 °C).

Meets 3-A sanitary standards.

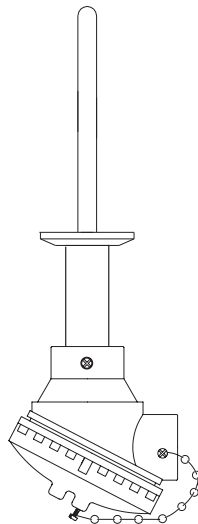

## Supplementary documentation

All important Temperature Operating Instructions, particularly with regard to head and field transmitters are available on CD-ROM, find enclosed or order by order number: SONDIT-AG.

- $\geq 10 \text{ M}\Omega$  at 572 °F (300 °C)
  - $\geq 100 \text{ M}\Omega$  at 77 °F (25 °C)
- sheath, test voltage 250 V.

Insulation resistance between terminals and probe  
Insulation resistance

## Characteristics performance (continued)

## Installation

### Installation locations

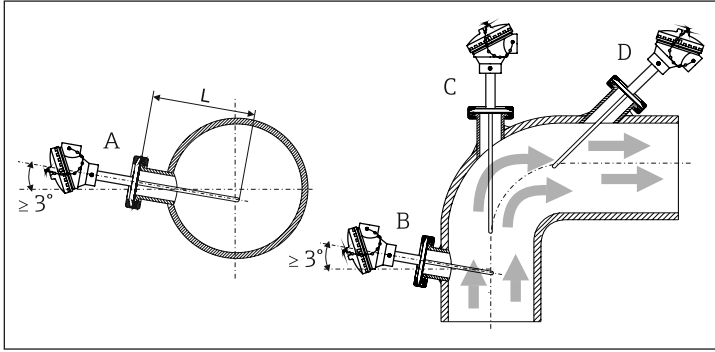

A - B: In pipes with a small cross section the sensor tip should reach or extend slightly past the center line of the pipe (= L). Installation with minimal 3° inclination because of self draining.  
C - D: Tilted installation.

For installation proceed as follows:

1. Make sure that the hygienic process fitting and the clamp assembly match the maximum specified process pressure.
2. Install and tighten the RTD sensor before applying process pressure.



Minimum immersion is 1¼" as per ASTM E644.

## Dimensions

in inches

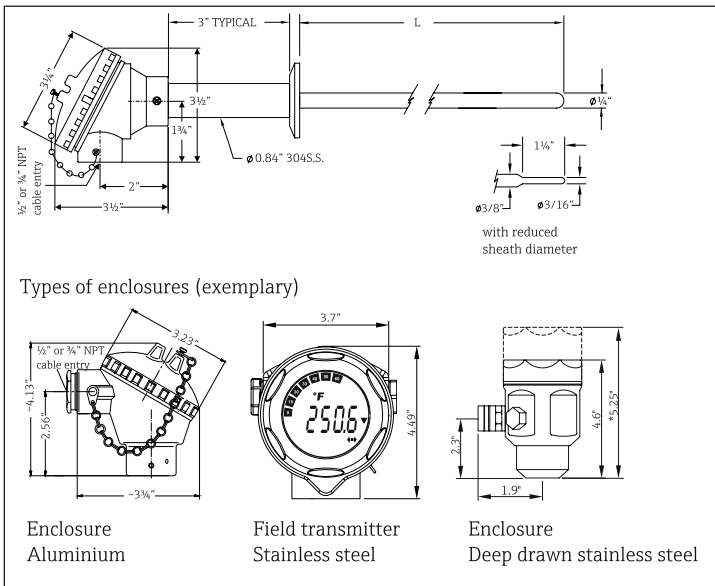

\* Dimensions with optional display.

Immersion length L	2", 2.5", 3", 4", 5", 6" specified length 2" to 30" in ½" increments
Process connection	Tri-clamp® connection (3-A® marked): 1+1½", 2", 2½", 3"

## Electrical connection-wiring diagrams

Transmitter mounted (3" or 5½" flying leads - crimped sleeves)

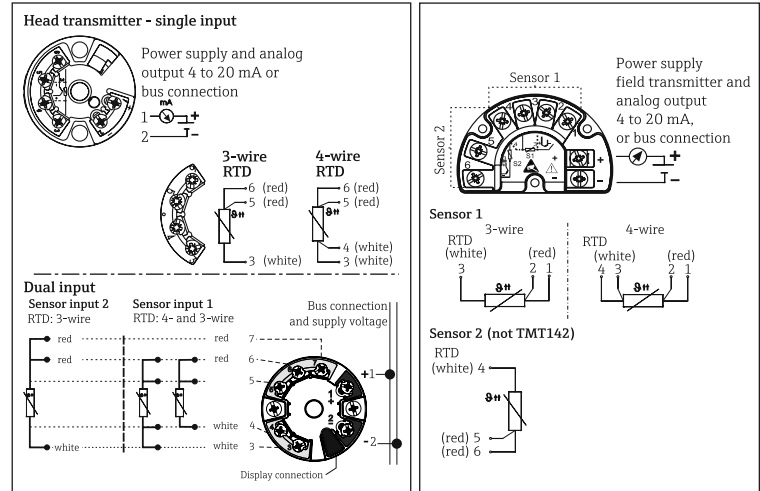

Terminal block mounted (3" flying leads - fork lugs)

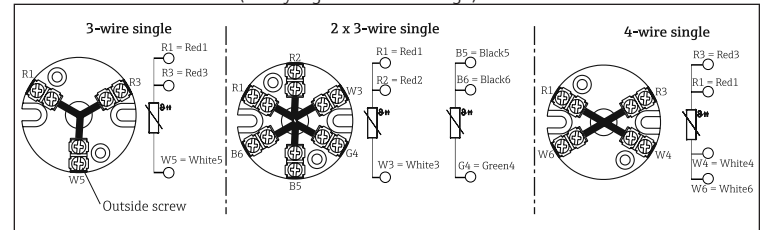

The blocks and transmitters are shown as they will sit inside the heads in reference to the conduit opening. ALWAYS terminate leads to the outside screw!

## Technical data

Weight: From 1 to 5.5 lbs  
Material: Wetted parts 316L SS  
Shock and vibration resistance: 4g/2 to 150 Hz as per IEC 60 068-2-6  
Ambient temperature limits:

Housing without head-mounted transmitter	
Aluminium pressure die-cast housing	-40 to 300 °F (-40 to 150 °C)
Plastic housing	-40 to 185 °F (-40 to 85 °C)
Deep drawn SS housing without display	-40 to 300 °F (-40 to 150 °C)
Housing with head-mounted transmitter	
Deep drawn SS housing with display	-4 to 160 °F (-20 to 70 °C)
Field transmitter	
with display	-40 to 158 °F (-40 to 70 °C)
without display	-40 to 185 °F (-40 to 85 °C)

## Performance Characteristics

Response time: 63% response time per ASTM E644

Construction	Ø ¼"	Ø 3/8" red. 3/16"
	4 s	3 s

Maximum measured error

Class	max. Tolerances (°C)*
A	± (0.15 + 0.002 ·  t )
1/5 DIN	± (0.06 + 0.001 ·  t )

\* |t| = absolute value °C. For measurement errors in °F, calculate using equation above in °C, then multiply the outcome by 1.8.