

Technical Information

Proline t-mass 65F, 65I

Thermal mass flowmeter



The high performing flowmeter with intelligent and dynamic adaptation to changing process conditions

F: Inline version, I: Insertion version

Application

- Measuring principle is characterized by a high operable flow range and direct mass flow measurement
- F: Measurement of gases and gas mixtures in small line sizes
- I: Measurement of gases and gas mixtures in circular piping or rectangular ducts

Device properties F

- Inline version: nominal diameter DN 15 to 100 (½ to 4")
- Process pressure up to PN 40, Class 300
- High accuracy: ±1.5 % o.r. (10 to 100 % o.f.s.)

Device properties I

- Insertion version for nominal diameter DN 80 to 1500 (3 to 60")
- Medium temperature up to +130 °C (266 °F)
- High accuracy: ±1.5 % o.r. (10 to 100 % o.f.s.)

Device properties 65

- Device in compact or remote version
- 4-20 mA HART, PROFIBUS PA/DP, Modbus RS485, FF
- Worldwide approvals (Hazardous area)

Your benefits

- Plant safety – high accuracy and repeatability for a wide range of utility and process gases
- Cost-effective measurement – easy installation, negligible pressure loss and maintenance-free
- Reliable flow trending – multivariable measurement
- Flexible device configuration to suit the application – integrated "Gas Engine" functionality
- For demanding applications – user-definable gas mixtures, high repeatability and accuracy
- Automatic recovery of data for servicing





Table of contents

Document information	3	Media	24
Symbols used	3	Pressure-temperature ratings	25
Function and system design	4	Limiting flow	26
Measuring principle	4	Pressure loss	26
Measuring system	4	System pressure	26
Input	5	Thermal insulation	26
Measured variable	5	Hot tap, process pressure	26
Measuring range	5	Cold tap, atmospheric pressure	26
Input signal	6	Mechanical construction	27
Output	7	Design, dimensions	27
Output signal	7	Weight	45
Signal on alarm	8	Materials	45
Load	9	Process connection	46
Low flow cut off	9	Operability	47
Galvanic isolation	9	Display elements	47
Switching output	9	Operating elements	47
Power supply	10	Languages	47
Terminal assignment	10	Remote operation	47
Device plug connectors	11	Certificates and approvals	47
Supply voltage	12	CE mark	47
Power consumption	12	C-Tick mark	47
Power supply failure	12	Ex approval	47
Potential equalization	12	FOUNDATION Fieldbus certification	47
Cable entries	12	PROFIBUS DP/PA certification	48
Remote version	12	Modbus RS485 certification	48
cable specifications	13	Pressure measuring device approval	48
Performance characteristics	14	Oxygen service	48
Reference operating conditions	14	Other standards and guidelines	48
Maximum measured error	14	Ordering information	49
Repeatability	15	Accessories	49
Reaction time	15	Device-specific accessories	49
Influence of medium pressure	15	Communication-specific accessories	49
(Pressure co-efficient)	15	Service-specific accessories	50
Installation	16	Documentation	50
Orientation	16	Registered trademarks	50
Inlet and outlet runs	17		
Mounting conditions for the insertion version	20		
Length of connecting cable	22		
Mounting wall-mount housing	22		
Environment	23		
Ambient temperature range	23		
Storage temperature	23		
Degree of protection	23		
Shock resistance	23		
Vibration resistance	23		
Electromagnetic compatibility	23		
Process	24		
Medium temperature range	24		







Document information

Symbols used

Electrical symbols

Symbol	Meaning
 A0011197	Direct current A terminal at which DC voltage is present or through which direct current flows.
 A0011198	Alternating current A terminal at which alternating voltage (sinusoidal) is present or through which alternating current flows.
 A0011200	Ground connection A grounded terminal which, as far as the operator is concerned, is grounded via a grounding system.
 A0011199	Protective ground connection A terminal which must be connected to ground prior to establishing any other connections.
 A0011201	Equipotential connection A connection that must be connected to the plant grounding system: This may be a potential equalization line or a star grounding system depending on national or company codes of practice.

Symbols for types of information

Symbol	Meaning
 A0011182	Permitted Indicates procedures, processes or actions that are permitted.
 A0011183	Preferred Indicates procedures, processes or actions that are preferred.
 A0011200	Forbidden Indicates procedures, processes or actions that are forbidden.
 A0011193	Tip Indicates additional information.
 A0011194	Reference to documentation Refers to the corresponding device documentation.
 A0011195	Reference to page Refers to the corresponding page number.
 A0011196	Reference to graphic Refers to the corresponding graphic number and page number.

Symbols in graphics

Symbol	Meaning
1, 2, 3 etc.	Item numbers
A, B, C etc.	Views
A-A, B-B, C-C etc.	Sections
 A0013441	Flow direction

Function and system design

Measuring principle

The thermal principle operates by monitoring the cooling effect of a gas stream as it passes over a heated transducer (PT100).

Gas flowing through the sensing section passes over two PT 100 RTD transducers one of which is used conventionally as a temperature sensing device, whilst the other is used as a heater. The temperature sensor monitors the actual process values whilst the heater is maintained at a constant differential temperature above this by varying the power consumed by the sensor. The greater the mass flow, the greater the cooling effect and power required to maintain the differential temperature. The measured heater power is therefore a measure of the gas mass flowrate.

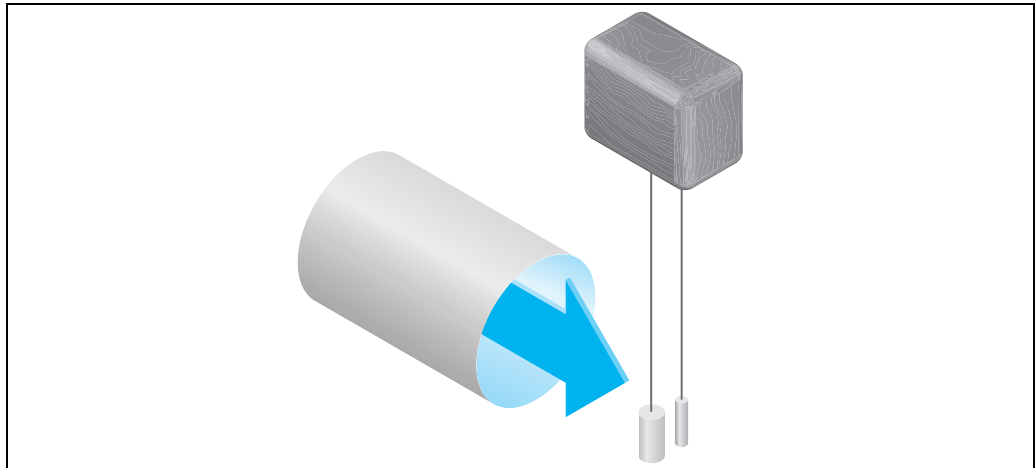

A0016823

Measuring system

The measuring device consists of a transmitter and a sensor. Two versions are available:

- Compact version: transmitter and sensor form a mechanical unit.
- Remote version: transmitter and sensor are mounted separately from one another.

Transmitter

<p>t-mass 65</p> <p>A0003671</p>	<ul style="list-style-type: none"> ▪ Two-line liquid-crystal display ▪ Configuration using push button operation
----------------------------------	--

Sensor

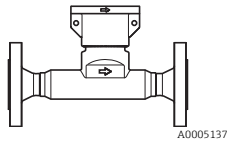
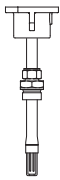
<p>F</p>  <p>A0005137</p>	<ul style="list-style-type: none"> ▪ Inline version ▪ Nominal diameter DN 15 to 100 (½ to 4") <p>Measuring tube materials:</p> <ul style="list-style-type: none"> ▪ Wetted parts: <ul style="list-style-type: none"> - 1.4404 (316L) - CF3M ▪ Non-wetted parts: <ul style="list-style-type: none"> - 1.4301 (304) <p>Transducer materials</p> <ul style="list-style-type: none"> ▪ 1.4404 (316L) ▪ Alloy C22 (optional)
<p>I</p>  <p>A0005138</p>	<ul style="list-style-type: none"> ▪ Insertion version ▪ Sensor length 235/335/435/608 for DN 80 to 1500 (9.25"/13.2"/17.1"/24" for 3 to 60") <p>Insertion tube materials:</p> <ul style="list-style-type: none"> ▪ 1.4404 (316/316L) <p>Transducer materials:</p> <ul style="list-style-type: none"> ▪ 1.4404 (316L) ▪ Alloy C22 (optional)

Input

Measured variable

- Mass flow
- Gas temperature
- Gas heat flow

Measuring range

Air under ambient conditions

The measuring range is dependant on the gas selection, line size and use of flow conditioner. Each measuring device is calibrated individually with air. A mathematical conversion is performed in the device to adapt to customized gases.

The table below defines the ranges available for air without a flow conditioner. To obtain information on other gases and process conditions, please contact your Endress+Hauser sales center, or use the Applicator selection software.

Measuring range for the EN (DIN)/JIS flanged versions, metric units:

DN	kg/h		Nm ³ /h at 0°C, 1.013 bar a		sft ³ /min. at 15°C, 1.013 bar a	
	min.	max.	min.	max.	min.	max.
15	0.5	53	0.38	41	0.23	25
25	2	200	1.5	155	1.0	96
40	6	555	4.6	429	3.0	266
50	10	910	7.7	704	5.0	436
80	20	2030	15.5	1570	10	974
100	38	3750	29	2900	18	1800

Measuring range for the ASME flanged version, US units:

DN	lb/h		Sm ³ /h at 59 °F, 14.7 psi a		sft ³ /min. at 59 °F, 14.7 psi a	
	min.	max.	min.	max.	min.	max.
½"	1.1	116	0.4	42	0.23	25
1"	4.4	440	1.6	160	1.0	96
1 ½"	13.2	1220	4.8	450	3.0	266
2"	22	2002	8	740	5.0	436
3"	44	4466	16	1656	10	974
4"	84	8250	30	3060	18	1800

Measuring range for the insertion version, metric units:

DN	kg/h		Nm ³ /h at 0°C, 1.013 bar a		sft ³ /min. at 15°C, 1.013 bar a	
	min.	max.	min.	max.	min.	max.
80	20	2030	15.5	1570	9.6	974
100	38	3750	29.0	2900	18	1800
150	50	7500	38	5800	24	3600
200	80	12500	62	9666	38	6000
250	120	20000	93	15468	58	9600
300	180	28000	139	21655	86	13440
400	300	50000	232	38670	144	24000
500	500	80000	386	61870	240	38400
600	700	115000	540	88940	336	55200
700	900	159000	696	122970	432	76300
1000	2000	320000	1546	247846	960	153600
1500	2500	720000	1933	556844	1200	345600

The flow rates shown are representative of the calibrated conditions only and do not necessarily reflect what the meter can measure under operating conditions and actual internal pipe dimensions found on site. To correctly size and select a meter, it is recommended that you either contact your local Endress+Hauser sales center or use Endress+Hauser's "Applicator" software package.

Special applications

High gas velocities (>70 m/s)

In the event of high gas velocities, it is advisable to read in the process pressure dynamically or to enter the pressure very precisely as a velocity-dependent correction is performed.

Light gases

- Due to the very high thermal conductivity of hydrogen (H₂) (9 times that of air) and the fact that hydrogen is the lightest of all gases, it can prove very difficult to reliably measure this gas. Depending on the application, the flow rates of hydrogen are often particularly slow and the flow profiles are not sufficiently developed. It is not unusual for the flows to be in the laminar range, whereas a turbulent flow regime would be required for optimum measurement.
- Despite loss of accuracy and linearity in hydrogen applications with low flow rates, the t-mass 65 measures with good repeatability and is therefore suitable for monitoring flow conditions (e.g. leak detection).
- A linear, reliable measured value is difficult to obtain in applications with light gases with a Reynolds number below RE 4000. While this can be improved by making a special adjustment in the lower flow range, a loss of accuracy and linearity should be expected. It is advisable to contact your Endress+Hauser sales center if your application involves media with Reynolds numbers below RE 4000.
- When mounting, please note that the recommended upstream distances should be doubled for very light gases such as helium and hydrogen. →  17

Input signal

Current input:

Active/passive selectable, galvanically isolated, resolution: 2 µA

- Active: 4 to 20 mA, R_i ≤ 150 Ω, U_{out} = 24 V DC, short-circuit proof
- Passive: 0/4 to 20 mA, R_i ≤ 150 Ω, U_{max} = 30 V DC



Note!

The current input can be configured for pressure, gas analyzer:

The measuring device can read out the composition of the gas from the gas analyzer and automatically update the first two components (e.g. GAS TYPE 1 and 2) in the programmed gas mixture. This makes a more accurate measurement available even in the case of variable gas compositions, e.g. variable methane and carbon dioxide components in a biogas application.

Status input (auxiliary input) for HART version

$U = 3$ to 30 V DC, $R_i = 5$ k Ω , galvanically isolated; switch level ± 3 to ± 30 V DC;
Configurable for: gas group, totalizer reset, positive zero return

Status input (auxiliary input) for PROFIBUS DP

$U = 3$ to 30 V DC, $R_i = 3$ k Ω , galvanically isolated; switch level: ± 3 to ± 30 V DC, independent of polarity.
Configurable for: positive zero return, error message reset

Status input (auxiliary input) for MODBUS RS485

$U = 3$ to 30 V DC, $R_i = 3$ k Ω , galvanically isolated; switch level: ± 3 to ± 30 V DC, independent of polarity.
Configurable for: totalizer reset, positive zero return, error message reset

Output

Output signal**Current output**

Active/passive selectable, galvanically isolated, time constant selectable (0.0 to 100.0 s), full scale value selectable, temperature coefficient: typically 0.005% o.f.s./ $^{\circ}$ C, resolution: 0.5 μ A

- Active: 0/4 to 20 mA, $R_L < 700$ Ω (for HART: $R_L \geq 250$ Ω)
- Passive: 4 to 20 mA; supply voltage V_s 18 to 30 V DC; $R_i \geq 150$ Ω

If the current output is used as a temperature output, please observe the following information:
Class B according to EN 60751

Pulse-frequency output

Active/passive selectable, galvanically isolated

- Active: 24 V DC, 25 mA (max. 250 mA during 20 ms), $R_L > 100$ Ω (Flexible I/O boards, see terminal assignment \rightarrow 11)
- Passive: Open Collector, 30 V DC, 250 mA
- Frequency output: full scale frequency 2 to 1000 Hz ($f_{\max} = 1250$ Hz), on/off ratio 1:1, pulse width max. 2 s, time constant selectable (0.0 to 100.0 s)
- Pulse output: pulse value and pulse polarity can be selected, pulse width adjustable (0.5 to 2000 ms; factory setting 20 ms)

FOUNDATION Fieldbus

- FOUNDATION Fieldbus H1, IEC 61158-2, galvanically isolated
- Data transmission rate: 31.25 kBit/s
- Current consumption: 12 mA
- Permitted supply voltage: 9 to 32 V
- Error current FDE (Fault Disconnection Electronic): 0 mA
- Bus connection with integrated reverse polarity protection
- Signal encoding: Manchester II
- ITK Version 5.01
- Function blocks:
 - 7 \times Analog Input (Execution time: each 18 ms)
 - 1 \times Analog Output (Execution time: 18 ms)
 - 1 \times Digital Output (18 ms)
 - 1 \times PID (25 ms)
 - 1 \times Arithmetic (20 ms)
 - 1 \times Input Selector (20 ms)
 - 1 \times Signal Characterizer (20 ms)
 - 1 \times Integrator (18 ms)
- Number of VCRs: 38
- Number of link objects in VFD: 40
- Output data: Mass flow, Corrected volume flow, Temperature, Totalizers 1 to 3
- Input data: Positive zero return (ON/OFF), Zero point adjustment, Measuring mode, Reset totalizer
- Link Master (LM) function is supported
- Available output combination \rightarrow 11

PROFIBUS DP

- PROFIBUS DP in accordance with EN 50170 Volume 2
- Profile Version 3.0
- Data transmission rate: 9.6 kBaud to 12 MBaud
- Automatic data transmission rate recognition
- Signal encoding: NRZ-Code
- Function blocks: 3 × Analog Input, 2 × Totalizer, 1 × Analog Output,
- Output data: Mass flow, Corrected volume flow, Temperature, Totalizers 1 to 2
- Input data: Positive zero return (ON/OFF), Zero point adjustment, Measuring mode, Totalizer control
- Bus address can be configured via miniature switches or via the local display (optional)
- Available output combination → 11

PROFIBUS PA

- PROFIBUS PA in accordance with EN 50170 Volume 2, IEC 61158-2 (MBP), galvanically isolated
- Data transmission rate: 31.25 kBit/s
- Current consumption: 11 mA
- Permitted supply voltage: 9 to 32 V
- Bus connection with integrated reverse polarity protection
- Error current FDE (Fault Disconnection Electronic): 0 mA
- Signal encoding: Manchester II
- Function blocks: 3 × Analog Input, 2 × Totalizer, 1 × Analog Output,
- Output data: Mass flow, Corrected volume flow, Temperature, Totalizers 1 to 2
- Input data: Positive zero return (ON/OFF), Zero point adjustment, Measuring mode, Totalizer control
- Bus address can be configured via miniature switches or via the local display (optional)
- Available output combination → 11

Modbus RS485

- Modbus device type: slave
- Address range: 1 to 247
- Supported function codes: 03, 04, 06, 08, 16, 23
- Broadcast: supported with the function codes 06, 16, 23
- Physical interface: RS485 in accordance with EIA/TIA-485 standard
- Supported baud rate: 1200, 2400, 4800, 9600, 19200, 38400, 57600, 115200 Baud
- Transmission mode: RTU or ASCII
- Response times:
 - Direct data access = typically 25 to 50 ms
 - Auto-scan buffer (data range) = typically 3 to 5 ms
- Available output combination → 11

Signal on alarm

Current output
Failsafe mode selectable (e.g. in accordance with NAMUR Recommendation NE 43)

Current input
Failsafe value selectable

Pulse/frequency output
Failsafe mode selectable

Status output:
"Non conductive" in the event of fault or power supply failure.

Relay output
"De-energized" in the event of fault or power supply failure.

FOUNDATION Fieldbus
Status message in accordance with the specifications of FOUNDATION Fieldbus

PROFIBUS DP/PA
Status and alarm messages in accordance with PROFIBUS Profile Version 3.0.

Modbus RS485
If an error occurs, the value "NaN" (not a number) is output for the measured values.

Load	See "Output signal"
Low flow cut off	Switch points for low flow cut off are programmable
Galvanic isolation	All circuits for inputs, outputs, and power supply are galvanically isolated from each other.
Switching output	Relay output: Normally closed (NC) or normally open (NO) contacts available (factory setting: relay 1 = NO, relay 2 = NC), max. 30 V / 0.5 A AC; 60 V / 0.1 A DC, galvanically isolated. Configurable for: error messages, limit values Factory setting: closed

Power supply

Terminal assignment

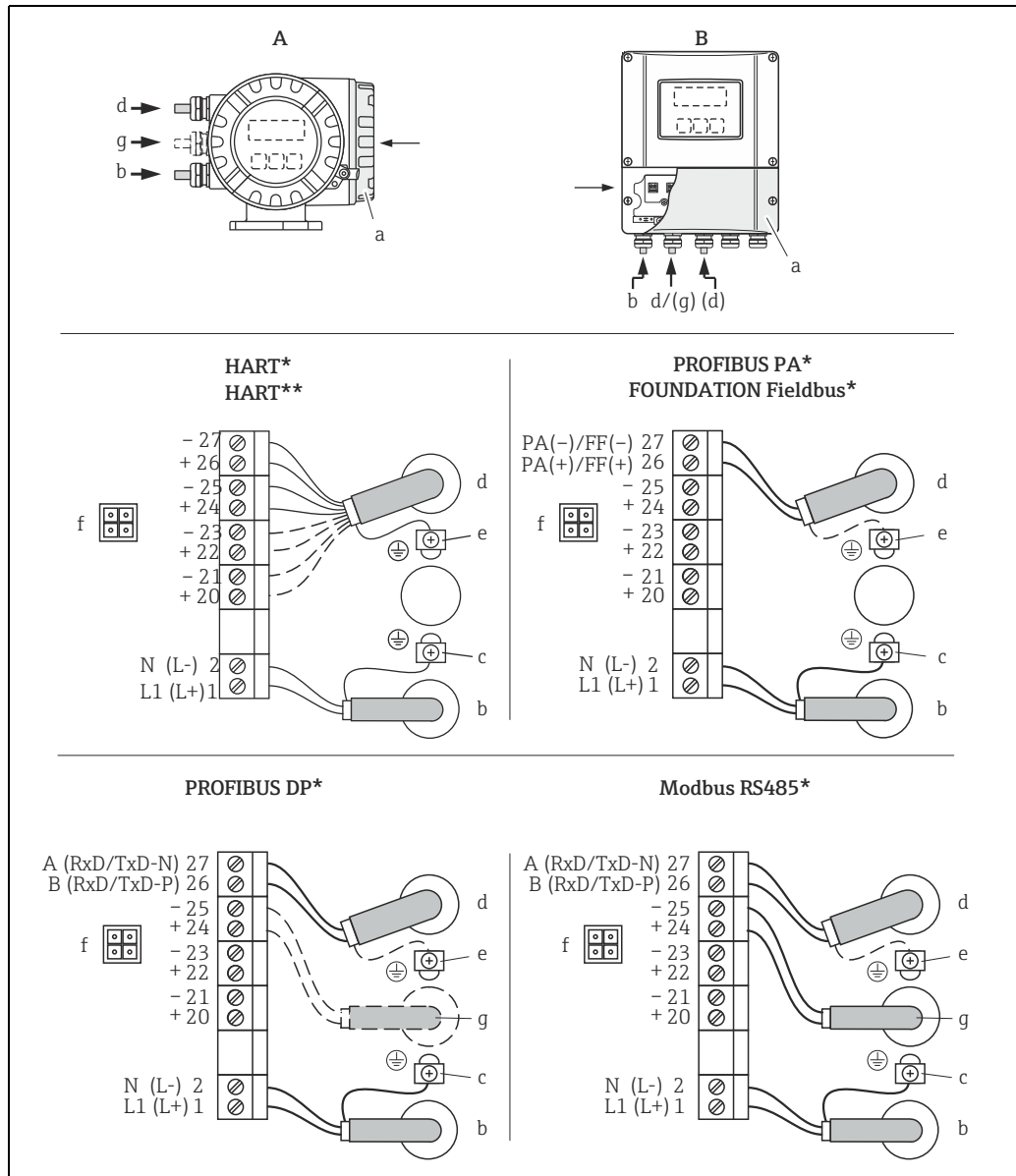

A0005135

Connecting the transmitter, cable cross-section max. 2.5 mm² (14 AWG)

A View A (field housing)

B View C (wall-mount housing)

*) fixed communication board

**) flexible communication board

a Connection compartment cover

b Cable for power supply: 85 to 260 V AC, 20 to 55 V AC, 16 to 62 V DC

Terminal No. 1: L1 for AC, L+ for DC

Terminal No. 2: N for AC, L- for DC

c Ground terminal for protective ground

d Signal cable: see Terminal assignment → 11

Fieldbus cable:

Terminal No. 26: DP (B) / PA (+) / FF (+) / MODBUS RS485 (B) / (PA, FF: with reverse polarity protection)

Terminal No. 27: DP (A) / PA (-) / FF (-) / MODBUS RS485 (A) / (PA, FF: with reverse polarity protection)

e Ground terminal for signal cable shield / fieldbus cable / RS485 line

f Service adapter for connecting service interface FXA 193 (Fieldcheck, FieldCare)

g Signal cable: see Terminal assignment → 11

Cable for external termination (only for PROFIBUS DP with permanent assignment communication board):

Terminal No. 24: +5 V

Terminal No. 25: DGND

Remote version

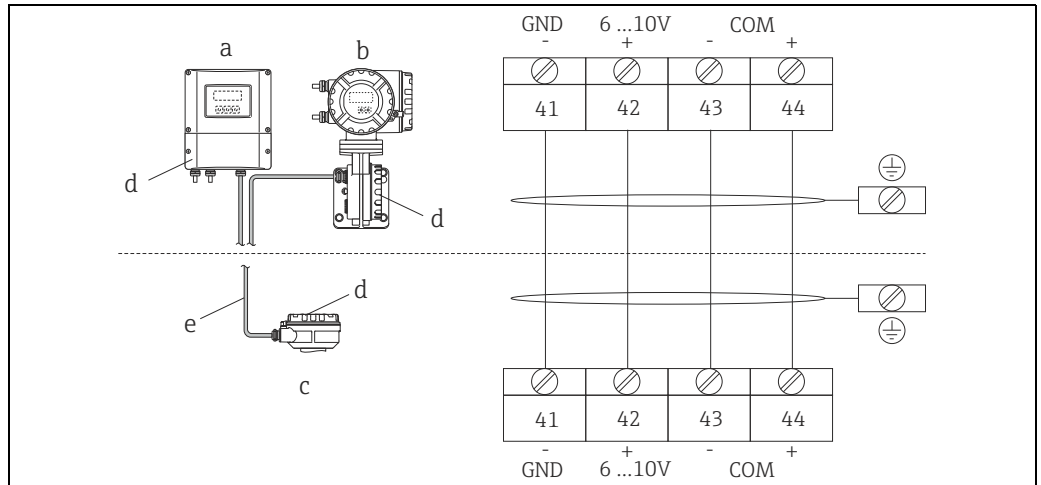

Connecting the remote version

- a Wall-mount housing transmitter: non-hazardous area and ATEX II3G / zone 2 → see separate "Ex documentation"
- b Wall-mount housing transmitter: ATEX II2G / Zone 1; FM/CSA → see separate "Ex documentation"
- c Connection housing sensor
- d Cover for connection compartment or connection housing
- e Connecting cable
- GND Ground connection
- COM Communication connection

Terminal No.:

41 = white; 42 = brown; 43 = green; 44 = yellow

Device plug connectors

Order version	Terminal No. (inputs/outputs)			
	20 (+) / 21 (-)	22 (+) / 23 (-)	24 (+) / 25 (-)	26 (+) / 27 (-)
<i>Fixed communication boards (permanent assignment)</i>				
65F**_*****A 65I_*****A	-	-	Frequency output	Current output HART
65F**_*****B 65I_*****B	Relay output	Relay output	Frequency output	Current output HART
65***_*****F 65I_*****F	-	-	-	PROFIBUS PA, Ex i
65***_*****G 65I_*****G	-	-	-	FOUNDATION Fieldbus Ex i
65***_*****H 65I_*****H	-	-	-	PROFIBUS PA
65***_*****J 65I_*****J	-	-	+5V (ext. termination)	PROFIBUS DP
65***_*****K 65I_*****K	-	-	-	FOUNDATION Fieldbus
65***_*****Q 65I_*****Q	-	-	Status input	Modbus RS485
65F**_*****R 65I_*****R	-	-	Current output 2 Ex i, active	Current output 1 Ex i active, HART
65F**_*****S 65I_*****S	-	-	Frequency output Ex i, passive	Current output Ex i Active, HART
65F**_*****T 65I_*****T	-	-	Frequency output Ex i, passive	Current output Ex i Passive, HART
65F**_*****U 65I_*****U	-	-	Current output 2 Ex i, passive	Current output 1 Ex i passive, HART
<i>Flexible communication boards</i>				
65F**_*****C 65I_*****C	Relay output 2	Relay output 1	Frequency output	Current output HART

Order version	Terminal No. (inputs/outputs)			
	20 (+) / 21 (-)	22 (+) / 23 (-)	24 (+) / 25 (-)	26 (+) / 27 (-)
65F**_*****D 65I_*****D	Status input	Relay output	Frequency output	Current output HART
65F**_*****E 65I_*****E	Status input	Relay output	Current output 2	Current output 1 HART
65F**_*****L 65I_*****L	Status input	Relay output 2	Relay output 1	Current output HART
65F**_*****2 65I_*****2	Relay output	Current output 2	Frequency output	Current output 1 HART
65F**_*****4 65I_*****4	Current input	Relay output	Frequency output	Current output HART
65F**_*****5 65I_*****5	Status input	Current input	Frequency output	Current output HART
65F**_*****6 65I_*****6	Status input	Current input	Current output 2	Current output HART
65F**_*****8 65I_*****8	Status input	Frequency output	Current output 2	Current output HART

Supply voltage 85 to 260 V AC, 45 to 65 Hz
20 to 55 V AC, 45 to 65 Hz
16 to 62 V DC

Power consumption

- AC: 85 to 260 V = 18.2 VA; 20 to 55 V = 14 VA ; (including sensor)
- DC: 8 W (including sensor)

Switch-on current:

- Max. 8 A (<5 ms) at 24 V DC
- Max. 4 A (<5 ms) at 260 V AC

Power supply failure Lasting minimum 1 power cycle

- EEPROM/HistoROM/T-DAT saves measuring device data if the power supply fails.
- HistoROM S-DAT is on exchangeable data storage chip with sensor specific data (pipe type, nominal diameter, serial number, flow conditioner, zero point, etc.).
- Totalizer stops at the last value determined

Potential equalization No special measures for potential equalization are required.
For instruments for use in hazardous areas, observe the corresponding guidelines in the specific Ex documentation.

Cable entries Power supply and signal cables (inputs/outputs):

- Cable entry M20 × 1.5 (8 to 12 mm (0.31 to 0.47 in))
- Thread for cable entries, ½" NPT, G ½"

Connecting cable for remote version:

- Cable entry M20 × 1.5 (8 to 12 mm (0.31 to 0.47 in))
- Thread for cable entries, ½" NPT, G ½"

**Remote version
cable specifications**

- $2 \times 2 \times 0.5 \text{ mm}^2$ (AWG 20) PVC cable with common shield (2 twisted pairs)
- Conductor resistance: $\leq 40 \text{ } \Omega/\text{km}$ [$\leq 131.2 \text{ } \Omega / 1000 \text{ ft}$]
- Capacitance, core/shield: $\leq 0.001 \text{ } \mu\text{F}/\text{m}$
- Inductance: $\leq 0.9 \text{ mH}/\text{m}$ [$\leq 2.952 \text{ mH}/\text{ft}$]
- Operating voltage: $\geq 250 \text{ V}$
- Temperature range: -40 to $+105 \text{ } ^\circ\text{C}$ [-40 to $+221 \text{ } ^\circ\text{F}$]
- Overall nominal diameter: 8.5 mm [$0.335 \text{"}]$
- Maximum cable length: 100 m [328 feet]

Use in environments with strong electrical interference:

The measuring device complies with the general safety requirements in accordance with EN 61010, the EMC requirements of IEC/EN 61326, and NAMUR recommendation NE 21/43.

The Ex documentation contains the cable specifications for the measuring devices that are used in hazardous areas.

Note

- The cable must be ordered separately.

Performance characteristics

Reference operating conditions

- Traceable to National Standards
- Accredited according to ISO/IEC 17025
- Air-controlled to $24\text{ °C} \pm 0.5\text{ °C}$ ($75.2\text{ °F} \pm 0.9\text{ °F}$) at atmospheric pressure
- Humidity-controlled $< 40\%$ RH

Maximum measured error

t-mass 65F and t-mass 65I

$\pm 1.5\%$ of reading for 100 % to 10 % of range (at reference conditions)

$\pm 0.15\%$ of full scale for 10 % to 1 % of range (at reference conditions)

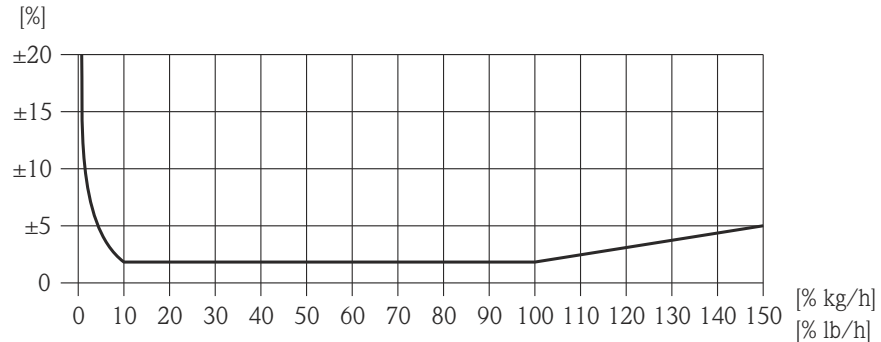

A0024121

Maximum measured error (% mass flow (Q)) as % of full scale value, see next table.

Order code for "Calibration flow" (not verified)	Performance characteristics	Description
G	Q = 100 to 150 %: ± 1.5 to $\pm 5\%$ of the current measured value increasing linearly as expressed in the following equation: $\pm 1.5 \pm (X_n - 100) \times 0.07 [\% \text{ o.r.}]$ ($100\% < X_n \leq 150\%$; X_n = current flow in % o.f.s.) Q = 10 to 100 % of full scale value ¹⁾ $\pm 1.5\%$ o.r. Q = 1 to 10 % of full scale value ¹⁾ $\pm 0.15\%$ o.f.s. (all data under reference conditions)	Factory calibration: The measuring device is calibrated and adjusted on an accredited and traceable calibration rig and its accuracy is certified in a calibration report (3 control points).
H	Q = 100 to 150 %: ± 1.5 to $\pm 5\%$ of the current measured value increasing linearly as expressed in the following equation: $\pm 1.5 \pm (X_n - 100) \times 0.07 [\% \text{ o.r.}]$ ($100\% < X_n \leq 150\%$; X_n = current flow in % o.f.s.) Q = 10 to 100 % of full scale value ¹⁾ $\pm 1.5\%$ o.r. Q = 1 to 10 % of full scale value ¹⁾ $\pm 0.15\%$ o.f.s. (all data under reference conditions)	Factory calibration + flow conditioner ²⁾ : The measuring device is calibrated and adjusted on an accredited and traceable calibration rig with a flow conditioner and its accuracy is certified in a calibration report (3 control points).

Order code for "Calibration flow" (not verified)	Performance characteristics	Description
K	Q = 100 to 150 %: ±1.5 to ±5 % of the current measured value increasing linearly as expressed in the following equation: $\pm 1.5 \pm (X_n - 100) \times 0.07$ [% o.r.] (100 % < X_n ≤ 150 %; X_n = current flow in % o.f.s.) Q = 10 to 100 % of full scale value ¹⁾ ±1.5 % o.r. Q = 1 to 10 % of full scale value ¹⁾ ±0.15 % o.f.s. (all data under reference conditions)	5-point, traceable ISO/IEC17025: The measuring device is calibrated and adjusted on an accredited and traceable calibration rig and its accuracy is certified in a Swiss Calibration Services (SCS) calibration report (5 control points), which confirms traceability to the national calibration standard.
L	Q = 100 to 150 %: ±1.5 to ±5 % of the current measured value increasing linearly as expressed in the following equation: $\pm 1.5 \pm (X_n - 100) \times 0.07$ [% o.r.] (100 % < X_n ≤ 150 %; X_n = current flow in % o.f.s.) Q = 10 to 100 % of full scale value ¹⁾ ±1.5 % o.r. Q = 1 to 10 % of full scale value ¹⁾ ±0.15 % o.f.s. (all data under reference conditions)	5-point, traceable ISO/IEC17025 + flow conditioner ²⁾ : The measuring device is calibrated and adjusted on an accredited and traceable calibration rig with a flow conditioner and its accuracy is certified in a Swiss Calibration Services (SCS) calibration report (5 control points), which confirms traceability to the national calibration standard.

1. The full scale value depends on the nominal diameter of the device and the maximum flow capacity of the calibration rig. The full scale values are listed in the following section.
2. A flow conditioner is also supplied.

Repeatability ±0.5 % of reading for velocities above 1.0 m/s (3.3 ft/s)

Reaction time Typically less than 2 seconds for 63 % of a given step change (in either direction).

Influence of medium pressure (Pressure co-efficient) Air: 0.35% per bar (0.02% per psi) of process pressure change (of set process pressure)

Installation

Thermal meters require a fully developed flow profile as a prerequisite for correct flow measurement. For this reason, please note the following points when installing the device.

Orientation

- The thermal dispersion principle is sensitive to disturbed flow conditions.
- Observe the recommended inlet and outlet requirements.
- Good engineering practice is necessary for the associated pipe work and installation.
- Ensure correct alignment and orientation of the sensor.
- Take measures to reduce or avoid condensation (e.g. install a condensation trap, thermal insulation, trace heating system etc.).
- The maximum permitted ambient temperatures and the medium temperature range (→ 23) must be observed.
- Install the transmitter in a shaded location or use a protective sun shield.
- For mechanical reasons, and in order to protect the pipe, it is advisable to support heavy sensors.

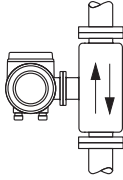
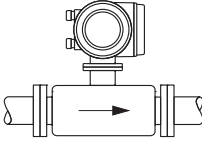
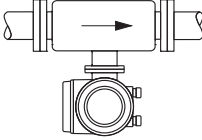
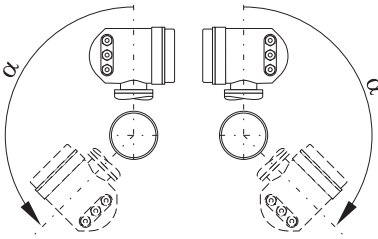
	Flanged sensor		Insertion sensor	
Vertical orientation	compact	remote	compact	remote
 <small>A0013785</small>	✓✓ ①	✓✓ ①	✓ ①, ②	✓✓ ①
Horizontal orientation, transmitter head up	compact/remote			
 <small>A0013786</small>	✓✓ ②			
Horizontal orientation, transmitter head down	compact/remote			
 <small>A0013787</small>	✓ ③			
Inclined orientation, transmitter head down	compact/remote			
 <small>A0009897</small>	✓ ④			

✓✓ = Recommended orientation

✓ = Orientation recommended in certain situations

① In the case of saturated or unclean gases, upward flow in a vertical pipe section is preferred to minimize condensation/contamination.

② Not recommended if the vibrations are high or if the installation is unstable.

③ Only suitable for clean/dry gases. Do not mount the sensor from the bottom, on horizontal pipes, if build-ups or condensate are likely to be present. Mount the sensor in a position as indicated below

④ If the gas is very wet or saturated with water (e. g. biogas, undried compressed air), mount in inclined orientation ($\alpha = \text{approx. } 135^\circ \pm 10^\circ$).

Inlet and outlet runs

The thermal dispersion principle is sensitive to disturbed flow conditions.

As a general rule, the thermal flowmeter should always be installed as far away as possible from any flow disturbances. For further information → ISO Standard 14511.

- Where two or more flow disturbances are located upstream of the meter, the recommended inlet length for the flow disturbance causing strongest disturbance must be used. For example if a control valve is additionally mounted upstream from the measuring device and an elbow on the inlet side, select the recommended inlet length for control valves: 50 × DN
- For very light gases such as Helium and Hydrogen all upstream distances should be doubled.

The minimum recommendations for inlet and outlet runs (without flow conditioner) are:

Flanged sensor

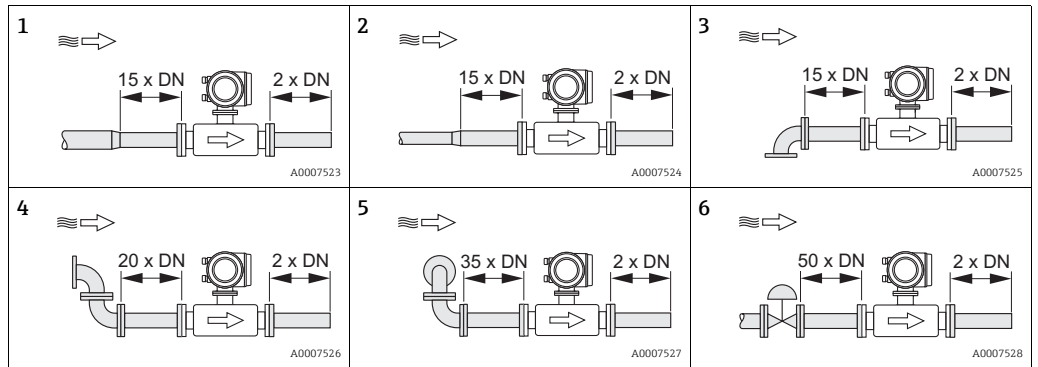

1 = Reduction, 2 = Expansion, 3 = 90° elbow or T-piece, 4 = 2 × 90° elbow, 5 = 2 × 90° elbow (3-dimensional), 6 = Control valve

Insertion sensor

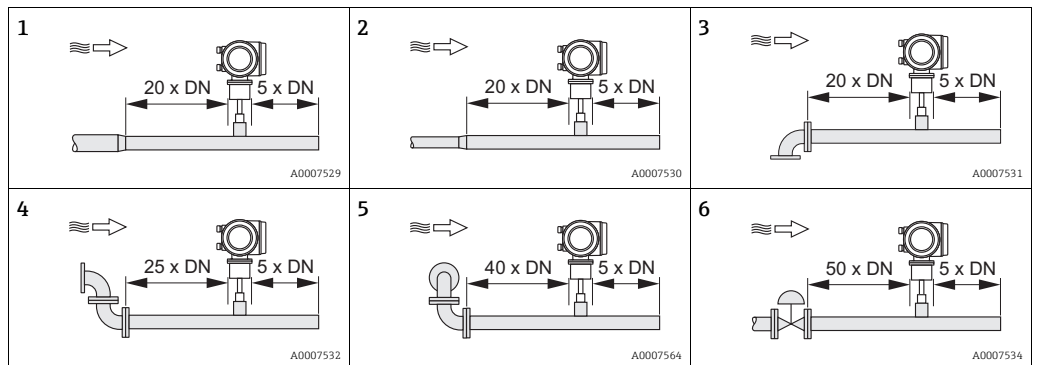

1 = Reduction, 2 = Expansion, 3 = 90° elbow or T-piece, 4 = 2 × 90° elbow, 5 = 2 × 90° elbow (3-dimensional), 6 = Control valve or pressure regulator

A specially designed perforated plate flow conditioner can be installed if it is not possible to observe the inlet runs required (→ 17).

Outlet runs with pressure measuring points

The pressure measuring point should be installed downstream of the measuring device, so that there is no potential influence of the pressure transmitter process connection on the flow entering the measuring point.

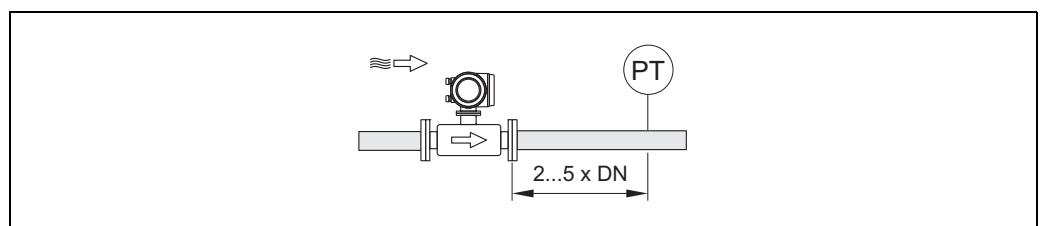

Installing a pressure measuring point (PT = pressure transmitter)

Perforated plate flow conditioner

It is recommended to install a perforated plate flow conditioner if the recommended inlet runs are not available.

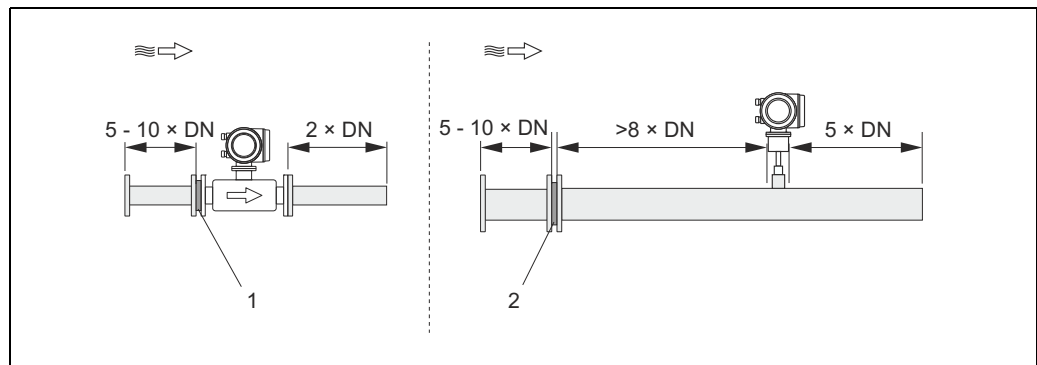

The figure above illustrates the minimum recommended inlet and outlet runs expressed in multiples of the pipe diameter using a flow conditioner.

1 = Flow conditioner with the flanged sensor, 2 = Flow conditioner with the insertion sensor

Flow conditioner for use with insertion sensors 65I → 49

The well known "Mitsubishi" design is recommended for this application DN 80 mm to DN 300 mm (3" to 12"). The flow conditioner must be installed at a minimum distance of $8 \times DN$ upstream of the sensor. A further 5 pipe diameters minimum inlet run is required upstream of the actual conditioner itself.

Measured errors can occur depending on disturbances in the inlet run. Therefore it is advisable to choose inlet runs that are as long as possible.



Note!

In the case of insertion devices, the inlet run selected downstream of the conditioner should be as long as possible.

Perforated plate flow conditioners (19 hole) for use with flanged sensor 65F → 49

This is a special Endress+Hauser version designed especially for use with the t-mass F sensor (sizes DN 25 to 100 (1 to 4")). The mounting hole patterns and sizing are of a multi-variant design which means that one plate will fit different flange pressure classes e.g. Cl. 150 and Cl. 300.

The flow conditioner and gaskets are fitted between the pipe flange and the measuring device. Use only standard bolts which match the flange bolt hole to guarantee that the flow conditioner is centered correctly.

The alignment notch must also be pointing in the same plane as the transmitter. Incorrect installation of the flow conditioner will have a small effect on the measurement accuracy.

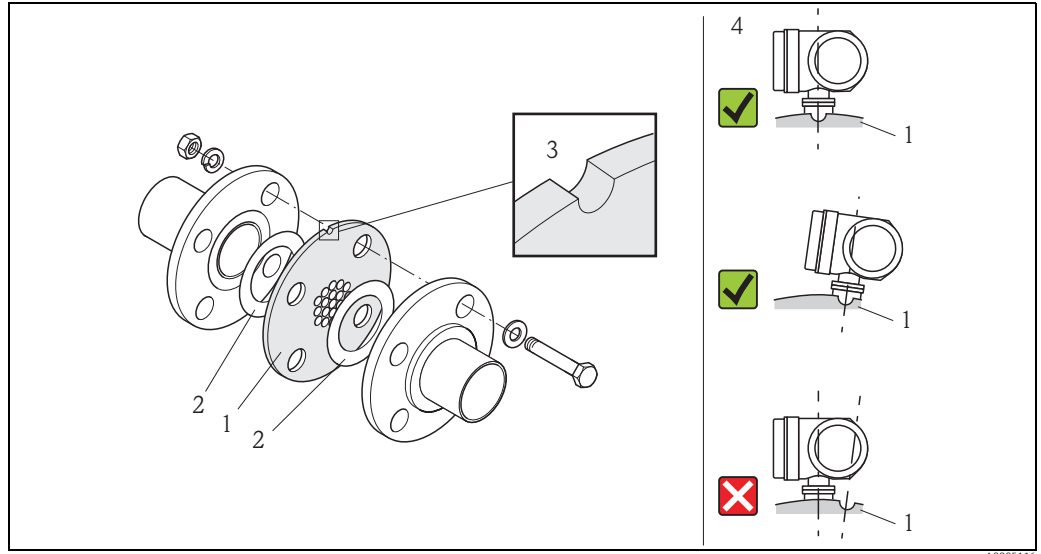

Flow conditioner mounting arrangement (example)

1 = Perforated plate flow conditioner, 2 = Seal/gasket, 3 = Notch, 4 = Correct pointing of alignment notch in the same plane as the transmitter

Note

- Order the t-mass F sensor and the flow conditioner together to ensure that they are calibrated together. Joint calibration guarantees optimum performance. Ordering the flow conditioner separately and using it with the device will further increase measurement uncertainty.
- The use of conditioners from other suppliers will affect the flow profile and pressure drop and will have an adverse effect on performance.
- Bolts, nuts, seals, etc. are not included in the scope of supply and must be supplied by the customer.

Pressure loss calculation

$$\Delta p = K \cdot \frac{\dot{m}^2}{\rho} \cdot \frac{1}{D^4}$$

Pressure loss: Δp in mbar or psi

Mass flow : \dot{m} in kg/h or lbm/h

Density: ρ in kg/m³ or lbm/ft³

Diameter: D in mm or inch

K (constant) = 1876 (SI units) or $8.4 \cdot 10^{-7}$ (US units)

Calculation examples:

\dot{m} = 148 kg/h or 326 lbm/h

ρ = 5.94 kg/m³ (at 5 bar abs at 20 °C) or 0.37 lbm/ft³ (at 72.5 psi abs at 68 °F)

D = 28.5 mm (for a DN 25, PN 40) or 1.05 in (for a 1" Class 150 Sched 40)

SI units

$$\Delta p = 1876 \cdot \frac{148^2}{5.94} \cdot \frac{1}{28.5^4} = 10.5 \text{ mbar}$$

US units

$$\Delta p = 8.4 \cdot 10^{-7} \cdot \frac{326^2}{0.371} \cdot \frac{1}{1.05^4} = 0.198 \text{ psi}$$

Pipework requirements

Good engineering practice should be followed at all times:

- Correct preparation, welding and finishing techniques
- Correctly sized gaskets
- Correctly aligned flanges and gaskets

- Connecting pipe work should match the internal diameter of the flowmeter. Maximum pipe diameter mismatch should not exceed:
 - 1 mm (0.04 in) for diameters < DN 200 (8")
 - 3 mm (0.12 in) for diameters ≥ DN 200 (8")
- New installations should be free of metallic and abrasive particles to prevent damage to the sensing elements on start-up

Further information is provided in ISO Standard 14511.

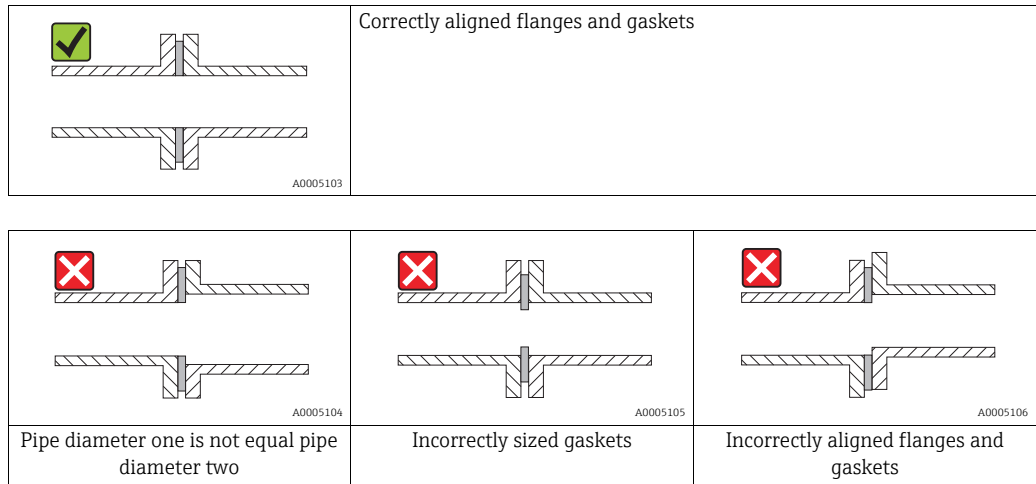

Mounting conditions for the insertion version

Selecting the length of the insertion sensor

The minimum required length of the insertion sensor can be determined by using Endress+Hauser's sizing tool, Applicator (version 10.02 or later "Accessories") or according to the following calculation steps.

The minimum required length of the insertion sensor is determined by the necessary insertion depth. The calculated insertion depth must lie within the adjustable range of the selected insertion sensor.

1. Determine the dimensions A, B, C1 and C2

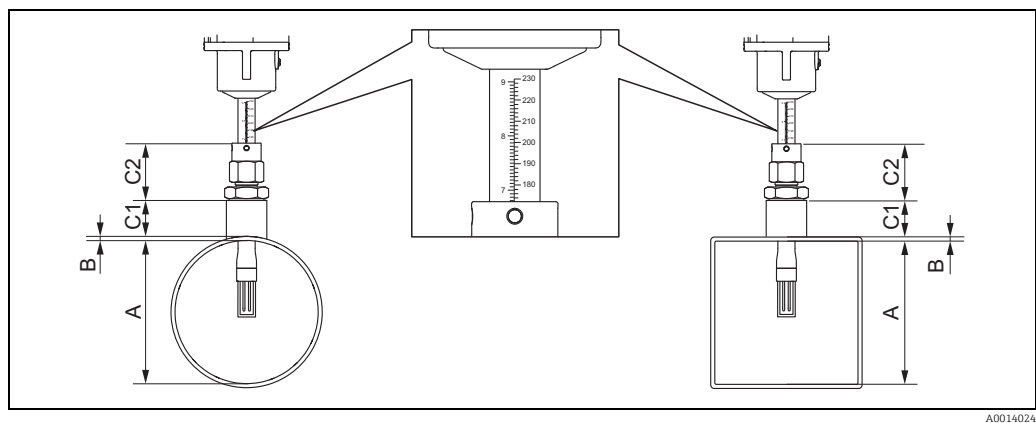

- A = For circular pipes: the internal pipe diameter (DN)
For rectangular pipes/ducts: the inner dimension
- B = Wall thickness of pipe or duct
- C1+C2 = Length of mounting set and insertion tube's compression fitting

Determine the dimensions C1 and C2

If only Endress+Hauser accessories are used	
DK6MB-BXA Mounting boss G1A:	C1 + C2 = 106 mm (4.17 in)
DK6MB-AXA Mounting boss 1" NPT:	C1 + C2 = 112 mm (4.41 in)

If it is intended not to solely use Endress+Hauser accessories	
C1	Height of pipe connection (mounting boss) used
C2	Process connection with G1A thread: 46mm (1.81 in)
	Process connection with NPT thread: 52mm (2.05 in)

- Calculate the insertion depth
 Insertion depth = $(0.3 \times A) + B + (C1 + C2) + 2 \text{ mm (0.08 in)}$
- A suitable insertion sensor length can be determined by comparing the calculated insertion depth with the following table.
 The calculated insertion depth must be within the adjusting range of the corresponding insertion sensor length!

Insertion length		Adjusting range (insertion depth)			
		G1A Thread		NPT Thread	
mm	in	mm	in	mm	in
235	9	120 to 230	4.7 to 9.0	126 to 230	4.96 to 9.0
335	13	120 to 330	4.7 to 13.0	126 to 330	4.96 to 13.0
435	17	120 to 430	4.7 to 17.0	126 to 430	4.96 to 17.0
608	24	120 to 604	4.7 to 23.8	126 to 604	4.96 to 23.8

Mounting conditions for welding sockets

When mounting the fitting to a thin wall duct, use a suitable support bracket for the sensor.
 $D = \varnothing 31.0 \pm 0.5 \text{ mm (1.22} \pm 0.019 \text{ in)}$

A0011843

Aligning the insertion version to flow direction

Check and ensure that the sensor is aligned vertically at a 90° angle on the pipe/duct. Turn the sensor so that the arrow marking matches the direction of flow.

A0007536

A0007537

Length of connecting cable Max. 100 m (328 ft), remote version (order separately)

Mounting wall-mount housing

- Make sure that ambient temperature does not go beyond the permissible range -20 to $+60$ °C (-4 to $+140$ °F), optional -40 to $+60$ °C (-40 to $+140$ °F).
- Install the device in a shady location. Avoid direct sunlight.
- Always install the wall-mount housing in such a way that the cable entries are pointing down.

Wall mounting

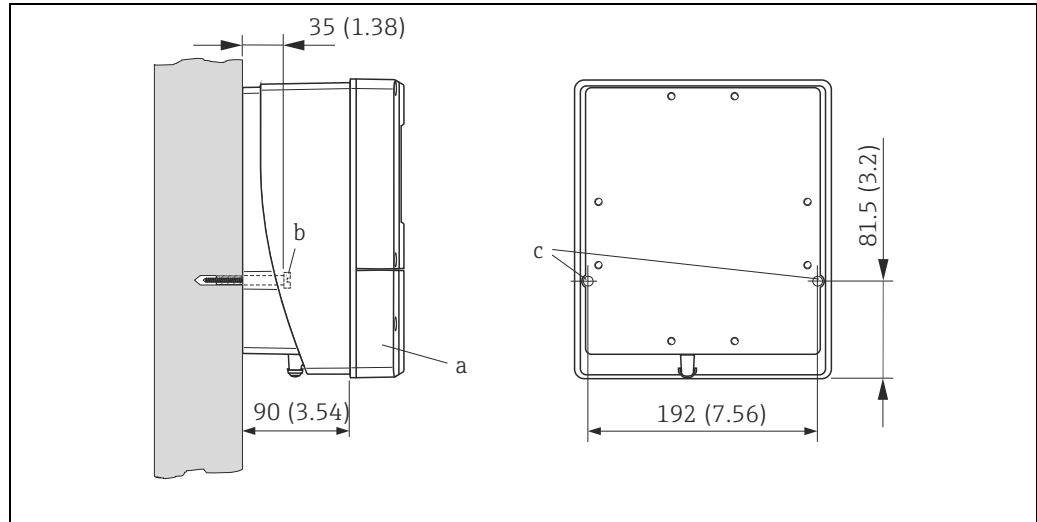

A0001130

Engineering unit mm (in)

a = Cover of the connection compartment

b = Securing screws (M6): max. \varnothing 6.5 mm (0.26"); screw head: max. \varnothing 10.5 mm (0.41")

c = Appropriate bores in the housing.

Pipe mounting and installation in control panel

If a warm pipe is used for installation, make sure that the housing temperature does not exceed the maximum permitted value of $+60$ °C. ($+140$ °F).

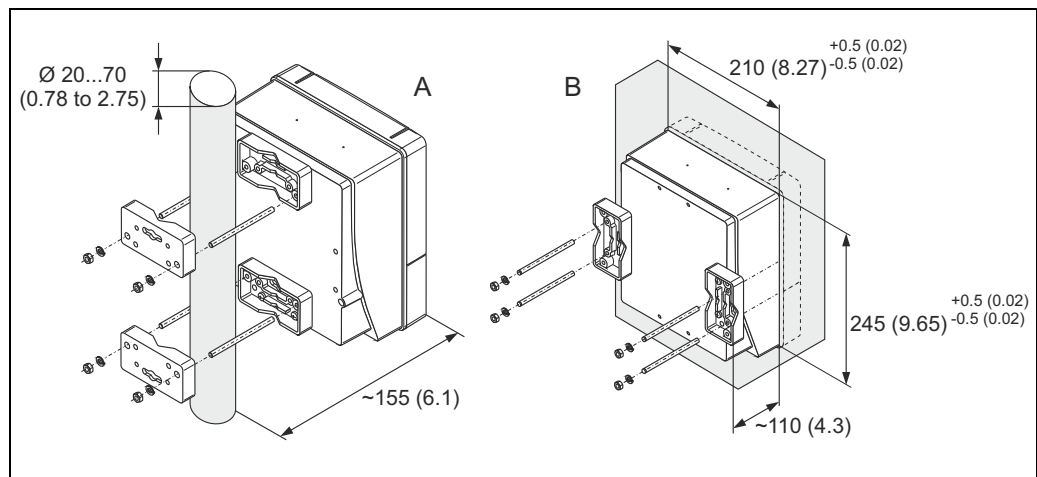

A0005256

Engineering unit mm (in)

A = Pipe mounting of wallmount housing

B = Installation in control panel of wallmount housing

Environment

Ambient temperature range	Standard: -20 to +60 °C (-4 to +140 °F) Optional: -40 to +60 °C (-40 to +140 °F) <ul style="list-style-type: none">■ Install the device in a shady location. Avoid direct sunlight, particularly in warm climatic regions. (A protective sun cover is available on request)■ At ambient temperatures below -20 °C (-4 °F) the readability of the display may be impaired.
Storage temperature	-40 to +80 °C (-40 to +176 °F), recommended: +20 °C (+68 °F)
Degree of protection	Standard: IP 67 (NEMA 4X) for transmitter and sensor
Shock resistance	According to IEC 60068-2-31
Vibration resistance	Acceleration up to 1 g, 10 to 150 Hz, following IEC 60068-2-6
Electromagnetic compatibility	To IEC/EN 61326 and NAMUR recommendation NE 21

Process

Medium temperature range

Sensor

t-mass F:

-40 to +100 °C (-40 to +212 °F)

t-mass I:

-40 to +130 °C (-40 to +266 °F)

Seals t-mass F

O-rings:

Viton FKM -20 to +100 °C (-4 to +212 °F)

Kalrez -20 to +100 °C (-4 to +212 °F)

EPDM -40 to +100 °C (-40 to +212 °F)

Bushing:

PEEK -40 to +100 °C (-40 to +212 °F)

Seals t-mass I

Bonded seals:

Kalrez -20 to +130 °C (-4 to +266 °F)

EPDM -40 to +130 °C (-40 to +266 °F)

Nitrile -35 to +130 °C (-31 to +266 °F)

Ferrule:

PEEK -40 to +130 °C (-40 to +266 °F)

Note

We recommend special materials (Alloy and PVDF) for aggressive media (e.g. chlorine or ozone). Please contact your Endress+Hauser sales center for clarification.

Media

The following media and media mixtures can be measured. A mixture can consist of up to 8 components from the following list.

AIR	ETHANE	METHANE
AMMONIA	ETHYLENE	NEON
ARGON	HELIUM 4	NITROGEN
BUTANE	HYDROGEN NORMAL	OXYGEN
CARBON DIOXIDE	HYDROGEN CHLORIDE	PROPANE
CARBON MONOXIDE	HYDROGEN SULFIDE	XENON
CHLORINE	KRYPTON	

Note

Other media (e.g. ozone) available on request. Contact your Endress+Hauser sales center for clarification.

Pressure-temperature ratings

Flange connections to EN 1092-1 (DIN 2501/DIN 2512N)

Flange material: stainless steel 1.4404/316L/316

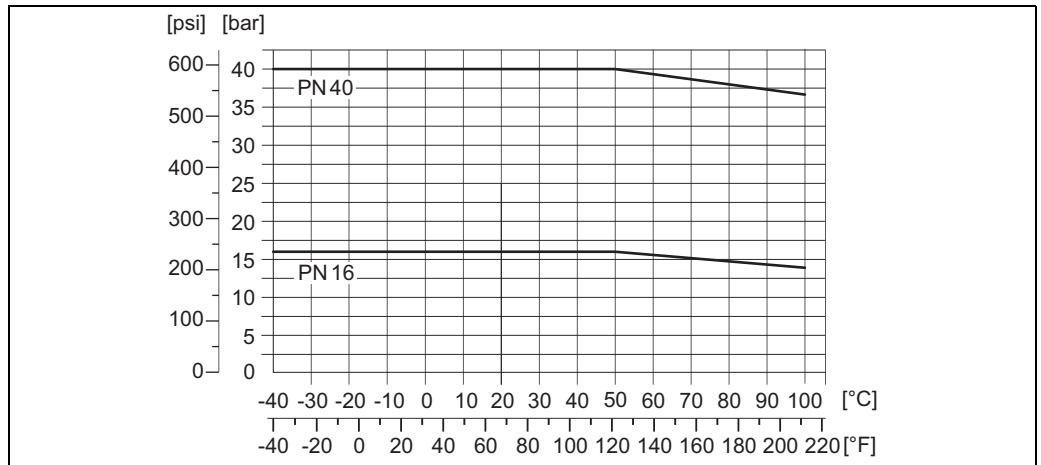

A0005240

Flange connections to JIS B2220

Flange material: stainless steel 1.4404/316L/316

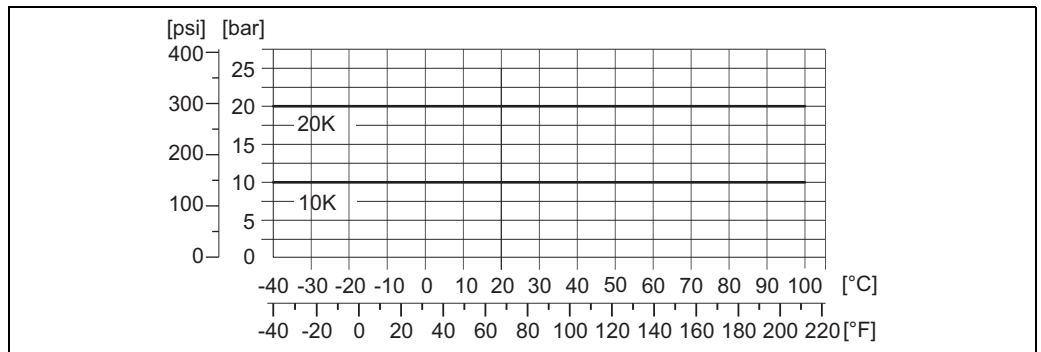

A0005241

Flange connection as per ASME B16.5

Flange material: stainless steel 1.4404/316L/316

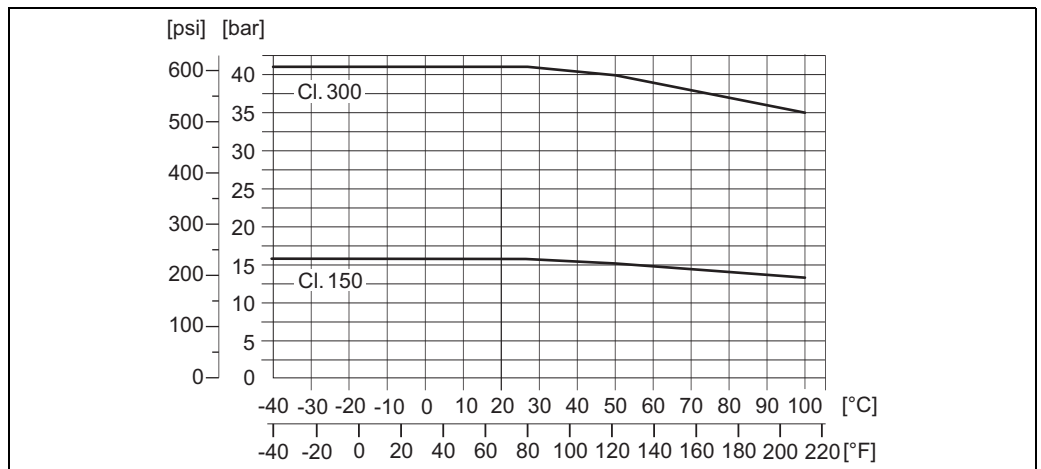

A0013825

Limiting flow	See "Measuring range" section → 5. The velocity in the measuring tube should not exceed 130 m/s (427 ft/s), (in air).
Pressure loss	Negligible (without flow conditioner). Refer to Applicator for the precise calculation
System pressure	t-mass F: -0.5 to 40 bar gauge (-7.25 to 580 psi gauge) t-mass I: -0.5 to 20 bar gauge (-7.25 to 290 psi gauge)
Thermal insulation	If the gas is very wet or saturated with water (e.g. biogas), the piping and sensor housing should be insulated, and heated where necessary, to prevent water droplets from condensing on the transducer.

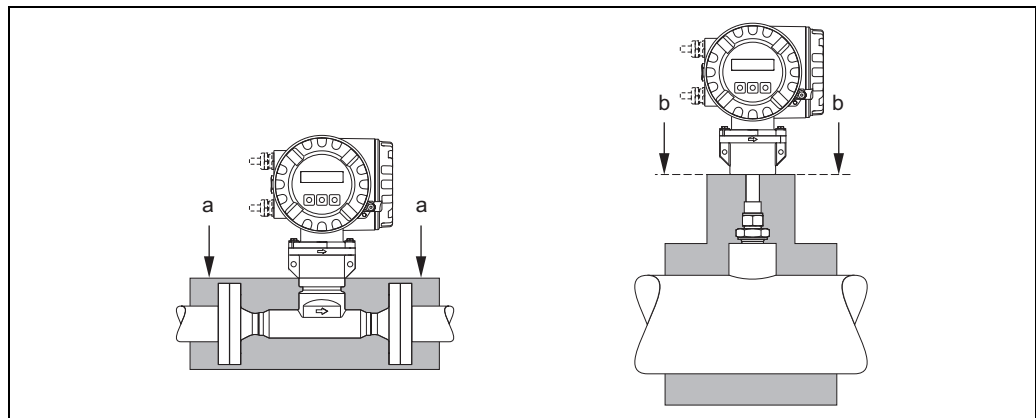

A0005122

Maximum thermal insulation for t-mass 65F and 65I

- a Maximum insulation height for the flanged sensor
b Maximum insulation height for the insertion sensor

Hot tap, process pressure	The Hot tap for mounting and removal at process pressure may only be used with non-toxic, innocuous gases classified as "Group II" in accordance with European Directive 67/548/EEC Art. 2. Medium pressure version Max. process pressure: 20 barg (290 psig) Max. extraction pressure: 16 barg (230 psig) Max. extraction temperature: +50 °C (+122 °F) Min. sensor length: 435 mm (17 in) Low pressure version Max. process pressure: 20 barg (290 psig) Max. extraction pressure: 4.5 barg (65 psig) Max. extraction temperature: +50 °C (+122 °F) Min. sensor length: 335 mm (13 in)
Cold tap, atmospheric pressure	Cold tap for mounting and removal at atmospheric pressure Max. process pressure: 20 barg (290 psig) Max. extraction pressure: 1 bar(a) (14.5 psia) Max. extraction temperature: +50 °C (+122 °F) Min. sensor length: 335 mm (13 in)

Mechanical construction

Design, dimensions

Dimensions:	
Transmitter remote version, connection housing (II2G/Zone 1), flange version	→ 27
Transmitter remote version, connection housing (II2G/Zone 1)	→ 28
Transmitter remote version, wall-mount housing (non Ex-zone and II3G/Zone 2)	→ 30
Mounting wall-mount housing	→ 22
Process connections in SI units	
t-mass 65F: Flange connections EN (DIN), JIS	→ 31
t-mass 65F: Flange connections as per ASME	→ 33
t-mass 65I: Compact insertion version	→ 35
t-mass 65I: Remote sensor housing insertion version	→ 35
Flow conditioner (as per EN (DIN) / JIS / ASME)	→ 36
Hot tap, process pressure	→ 37
Cold tap, atmospheric pressure	→ 38
Process connections in US units	
t-mass 65F: Flange connections as per ASME	→ 39
t-mass 65I: Compact insertion version	→ 41
t-mass 65I: Remote sensor housing insertion version	→ 41
Flow conditioner according to ASME	→ 42
Hot tap, process pressure	→ 43
Cold tap, atmospheric pressure	→ 44

Transmitter remote version, connection housing (II2G/Zone 1), flange version

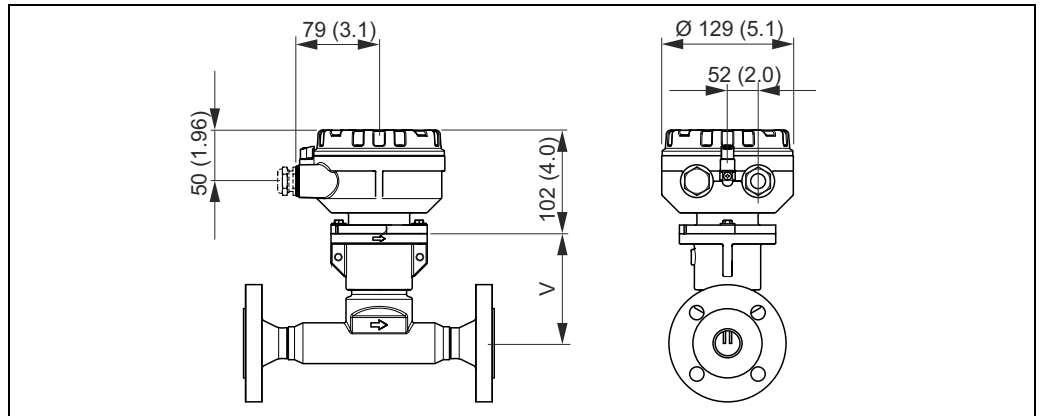

Engineering unit mm (in); dimensions "V": → [31](#) and → [33](#)

Transmitter remote version, connection housing (II2G/Zone 1)

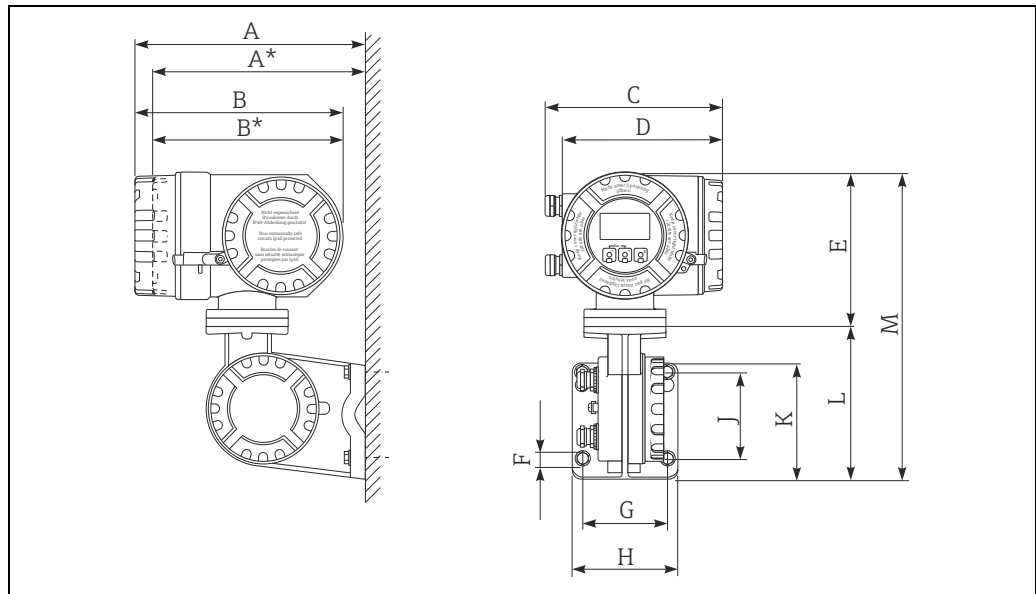

A0006999

Dimensions in SI units

A	A*	B	B*	C	D	E	F Ø	G	H	J	K	L	M
265	242	240	217	206	186	178	8.6 (M8)	100	130	100	144	170	348

* Blind version (without display)
All dimensions in [mm]

Dimensions in US units

A	A*	B	B*	C	D	E	F Ø	G	H	J	K	L	M
10.4	9.53	9.45	8.54	8.11	7.32	7.01	0.34 (M8)	3.94	5.12	3.94	5.67	6.69	13.7

* Blind version (without display)
All dimensions in [in]

Pipe mounting of the remote field housing

If a warm pipe is used for installation, make sure that the housing temperature does not exceed the max. permitted value of +60 °C (+140 °F).

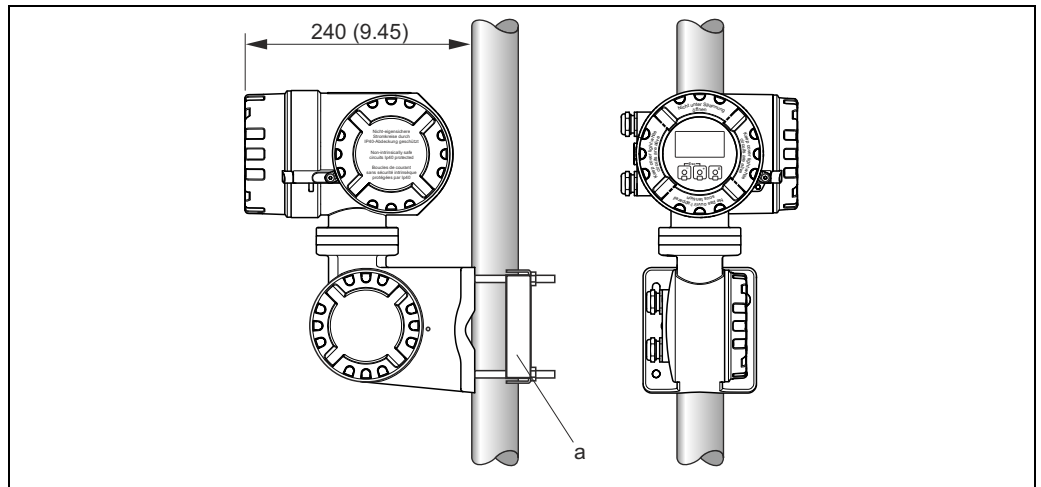

A0005157

Engineering unit mm (in); a = pipe mounting (separate mounting set, see accessories)

Transmitter remote version, wall-mount housing (non Ex-zone and II3G/Zone 2)

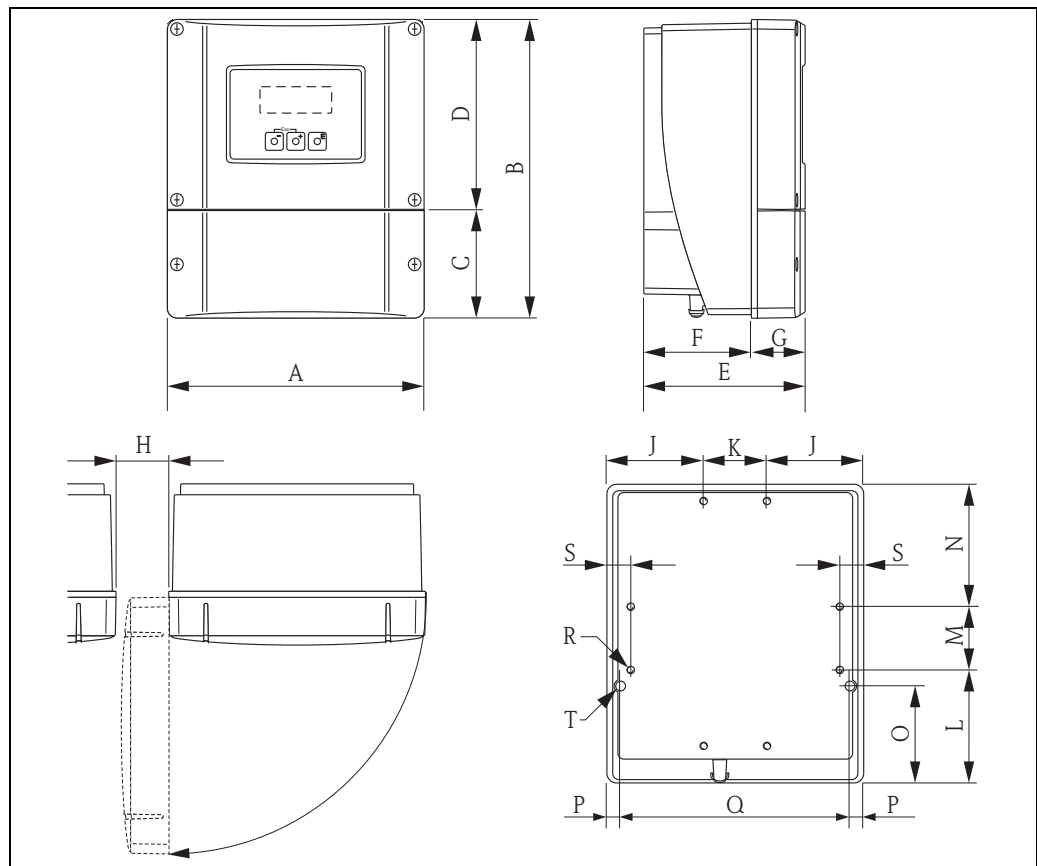

A0001150

Dimensions in SI units

A	B	C	D	E	F	G	H	J	K
215	250	90.5	159.5	135	90	45	>50	81	53
L	M	N	O	P	Q	R	S	T ¹⁾	
95	53	102	81.5	11.5	192	8 × M5	20	2 × Ø 6.5	

¹⁾ Fixing bolt for wall assembly: M6 (screw head max. 10.5 mm)
All dimensions in [mm]

Dimensions in US units

A	B	C	D	E	F	G	H	J	K
8.46	9.84	3.56	6.27	5.31	3.54	1.77	>1.97	3.18	2.08
L	M	N	O	P	Q	R	S	T ¹⁾	
3.74	2.08	4.01	3.20	0.45	7.55	8 × M5	0.79	2 × Ø 0.26	

¹⁾ Fixing bolt for wall assembly: M6 (screw head max. 0.41 in)
All dimensions in [in]

Process connections in SI units

t-mass 65F: Flange connections EN (DIN), JIS

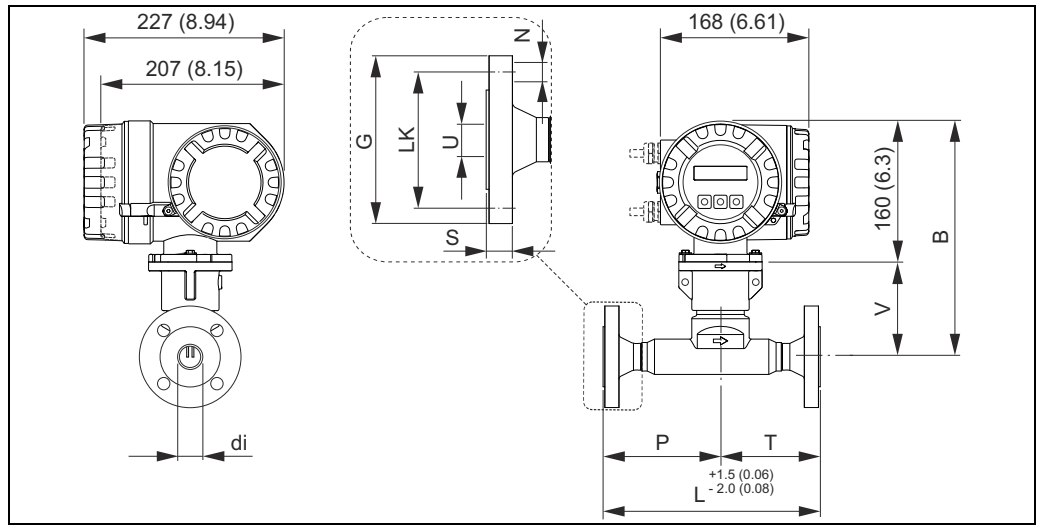

Engineering unit mm (in)

Flange EN 1092-1 (DIN 2501 / DIN 2512N 1) / PN 16: 1.4404/316L/316											
Surface roughness (flange): EN 1092-1 Form B1 (DIN 2526 Form C), Ra 6.3 to 12.5 µm											
DN	di	B	G	L	LK	N	P	S	T	U	V
100	97	303	220	800	180	8 × Ø18	500.5	20	299.5	107.1	143

¹⁾ Flange with groove to EN 1092-1 Form D (DIN 2512N) available
All dimensions in [mm]

Flange EN 1092-1 (DIN 2501 / DIN 2512N ¹⁾) / PN 40: 1.4404/316L/316											
Surface roughness (flange): EN 1092-1 Form B1 (DIN 2526 Form C), Ra 6.3 to 12.5 µm											
DN	di	B	G	L	LK	N	P	S	T	U	V
15	13.9	276.5	95	245	65	4 × Ø14	132.5	16	112.5	17.3	116.5
25	24.3	276.5	115	245	85	4 × Ø14	132.5	18	112.5	28.5	116.5
40	38.1	273.5	150	320	110	4 × Ø18	200	18	120	43.1	113.5
50	49.2	278.5	165	400	125	4 × Ø18	250	20	150	54.5	118.5
80	73.7	291	200	640	160	8 × Ø18	400	24	240	82.5	131
100	97	303	235	800	190	8 × Ø22	500.5	24	299.5	107.1	143

¹⁾ Flange with groove to EN 1092-1 Form D (DIN 2512N) available
All dimensions in [mm]

Flange JIS B2220/ 10K / Sched 40: 1.4404/316L/316											
Surface roughness (flange): Ra 3.2 to 6.3 µm											
DN	di	B	G	L	LK	N	P	S	T	U	V
50	49.2	278.5	155	400	120	4 × Ø19	250.0	17.5	150.0	52.7	118.5
80	73.7	291.0	185	640	150	8 × Ø19	400.0	20	240.0	78.1	131.0
100	97.0	303.0	210	800	175	8 × Ø19	500.5	20	299.5	102.3	143.0

All dimensions in [mm]

Flange JIS B2220/ 10K / Sched 80: 1.4404/316L/316											
Surface roughness (flange): Ra 3.2 to 6.3 μm											
DN	di	B	G	L	LK	N	P	S	T	U	V
50	49.2	278.5	155	400	120	4 \times \varnothing 19	250.0	17.5	150.0	49.2	118.5
80	73.7	291.0	185	640	150	8 \times \varnothing 19	400.0	20	240.0	73.7	131.0
100	97.0	303.0	210	800	175	8 \times \varnothing 19	500.5	20	299.5	97.0	143.0
All dimensions in [mm]											

Flange JIS B2220/ 20K / Sched 40: 1.4404/316L/316											
Surface roughness (flange): Ra 3.2 to 6.3 μm											
DN	di	B	G	L	LK	N	P	S	T	U	V
15	13.9	276.5	95	245	70	4 \times \varnothing 15	132.5	15	112.5	16.1	116.5
25	24.3	276.5	125	245	90	4 \times \varnothing 19	132.5	17	112.5	27.2	116.5
40	38.1	273.5	140	320	105	4 \times \varnothing 19	200	19	120	41.2	113.5
50	49.2	278.5	155	400	120	8 \times \varnothing 19	250	20	150	52.7	118.5
80	73.7	291.0	200	640	160	8 \times \varnothing 23	400	22	240	78.1	131.0
100	97	303.0	225	800	185	8 \times \varnothing 23	500.5	24	299.5	102.3	143.0
All dimensions in [mm]											

Flange JIS B2220/ 20K / Sched 80: 1.4404/316L/316											
Surface roughness (flange): Ra 3.2 to 6.3 μm											
DN	di	B	G	L	LK	N	P	S	T	U	V
15	13.9	276.5	95	245	70	4 \times \varnothing 15	132.5	15	112.5	13.9	116.5
25	24.3	276.5	125	245	90	4 \times \varnothing 19	132.5	17	112.5	24.3	116.5
40	38.1	273.5	140	320	105	4 \times \varnothing 19	200	19	120	38.1	113.5
50	49.2	278.5	155	400	120	8 \times \varnothing 19	250	20	150	49.2	118.5
80	73.7	291.0	200	640	160	8 \times \varnothing 23	400	22	240	73.7	131.0
100	97	303.0	225	800	185	8 \times \varnothing 23	500.5	24	299.5	97	143.0
All dimensions in [mm]											

t-mass 65F: Flange connections as per ASME

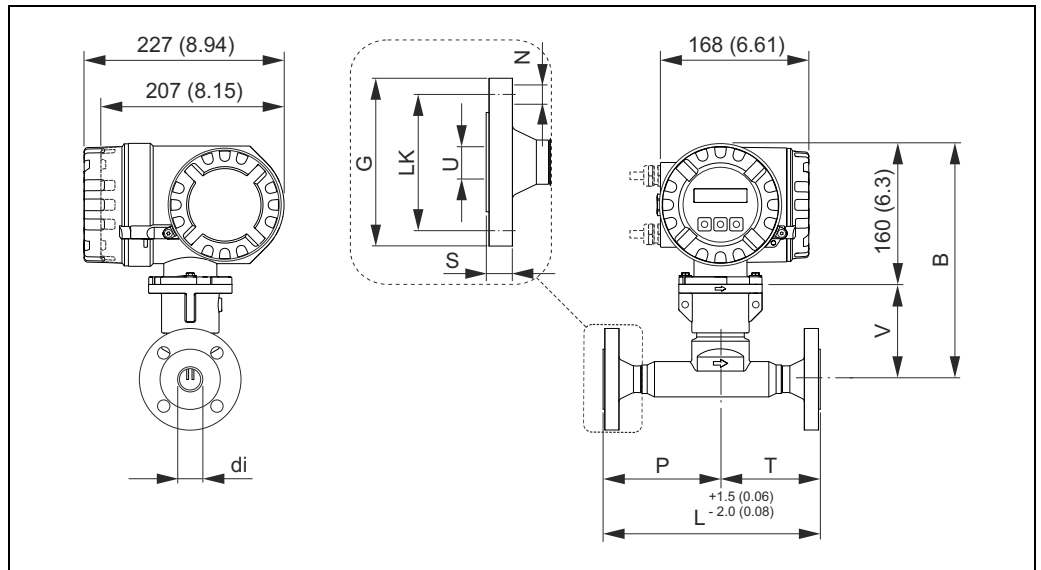

A0005162

Engineering unit mm (in)

Flange ASME B16.5 / Cl 150 / Sched 40: 1.4404/316L/316
 Surface roughness (flange): N9 / 250 µin

DN	di	B	G	L	LK	N	P	S	T	U	V
15	½"	13.9	276.4	88.9	245	4 × Ø 15.7	132.5	11.2	112.5	15.7	112
25	1"	24.3	276.4	108.0	245	4 × Ø 15.7	132.5	14.2	112.5	26.7	112
40	1 ½"	38.1	273.6	127.0	320	4 × Ø 15.7	200	17.5	120	40.9	109
50	2"	49.2	278	152.4	400	4 × Ø 19.1	250	19.1	150	52.6	118
80	3"	73.7	291.1	190.5	640	4 × Ø 19.1	400	23.9	240	78.0	127
100	4"	97	303.0	228.6	800	8 × Ø 19.1	500.5	24.5	299.5	102.4	139

All dimensions in [mm]

Flange ASME B16.5 / Cl 150 / Sched 80: 1.4404/316L/316
 Surface roughness (flange): N9 / 250 µin

DN	di	B	G	L	LK	N	P	S	T	U	V
15	½"	13.9	276.4	88.9	245	4 × Ø 15.7	132.5	11.2	112.5	13.9	112
25	1"	24.3	276.4	108.0	245	4 × Ø 15.7	132.5	14.2	112.5	24.3	112
40	1 ½"	38.1	273.6	127.0	320	4 × Ø 15.7	200	17.5	120	38.1	109
50	2"	49.2	278	152.4	400	4 × Ø 19.1	250	19.1	150	49.2	118
80	3"	73.7	291.1	190.5	640	4 × Ø 19.1	400	23.9	240	73.7	127
100	4"	97	303.0	228.6	800	8 × Ø 19.1	500.5	24.5	299.5	97.0	139

All dimensions in [mm]

Flange ASME B16.5 / Cl 300 / Sched 40: 1.4404/316L/316												
Surface roughness (flange): N9 / 250 µin												
DN	di	B	G	L	LK	N	P	S	T	U	V	
15	½"	13.9	276.4	95.2	245	66.5	4 × Ø 15.7	132.5	14.2	112.5	15.7	112
25	1"	24.3	276.4	124.0	245	88.9	4 × Ø 19.1	132.5	17.5	112.5	26.7	112
40	1 ½"	38.1	273.6	155.4	320	114.3	4 × Ø 22.4	200	20.6	120	40.9	109
50	2"	49.2	278	165.1	400	127.0	8 × Ø 19.1	250	22.4	150	52.6	118
80	3"	73.7	291.1	209.6	640	168.1	8 × Ø 22.4	400	28.4	240	78.0	127
100	4"	97	303.0	254.0	800	200.2	8 × Ø 22.4	500.5	31.8	299.5	102.4	139
All dimensions in [mm]												

Flange ASME B16.5 / Cl 300 / Sched 80: 1.4404/316L/316												
Surface roughness (flange): N9 / 250 µin												
DN	di	B	G	L	LK	N	P	S	T	U	V	
15	½"	13.9	276.4	95.2	245	66.5	4 × Ø 15.7	132.5	14.2	112.5	13.9	112
25	1"	24.3	276.4	124.0	245	88.9	4 × Ø 19.1	132.5	17.5	112.5	24.3	112
40	1 ½"	38.1	273.6	155.4	320	114.3	4 × Ø 22.4	200	20.6	120	38.1	109
50	2"	49.2	278	165.1	400	127.0	8 × Ø 19.1	250	22.4	150	49.2	118
80	3"	73.7	291.1	209.6	640	168.1	8 × Ø 22.4	400	28.4	240	73.7	127
100	4"	97	303.0	254.0	800	200.2	8 × Ø 22.4	500.5	31.8	299.5	97.0	139
All dimensions in [mm]												

t-mass 65I: Compact insertion version

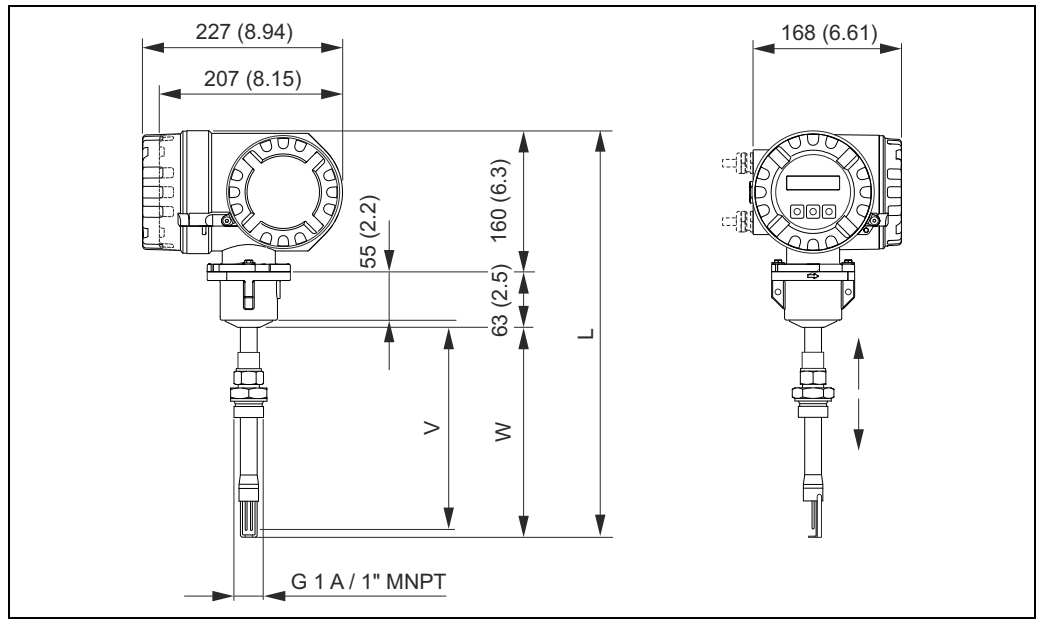

Engineering unit mm (in)

t-mass 65I: Remote sensor housing insertion version

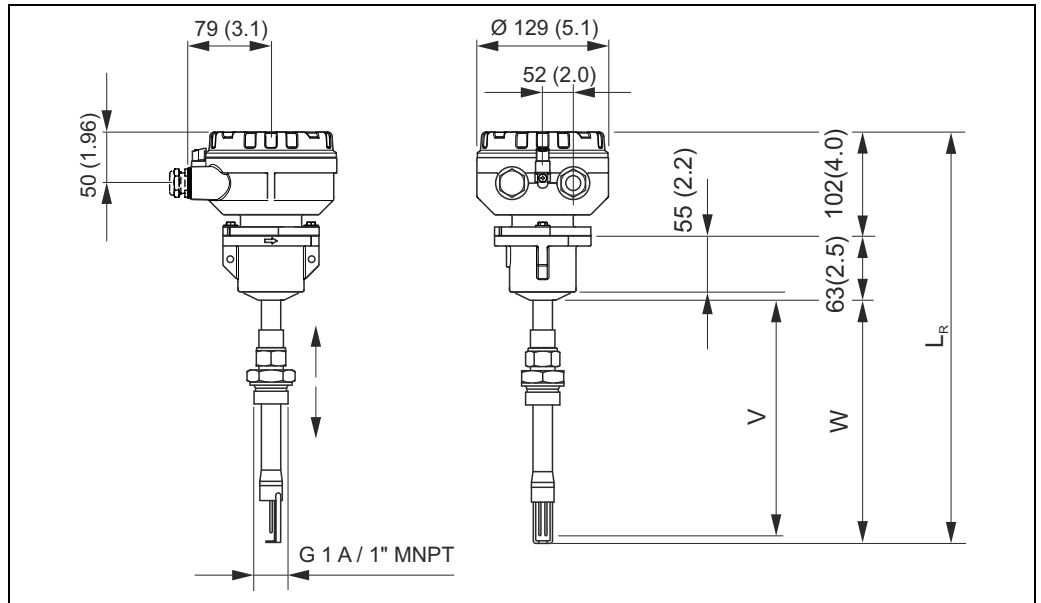

Engineering unit mm (in)

Length tmass 65I	V	W	L	L _R
235	235.1	252.6	475.6	417.6
335	335.1	352.6	575.6	517.6
435	435.1	452.6	675.6	617.6
608	608.1	625.6	848.6	790.6
All dimensions in [mm].				

Flow conditioner (as per EN (DIN) / JIS / ASME)

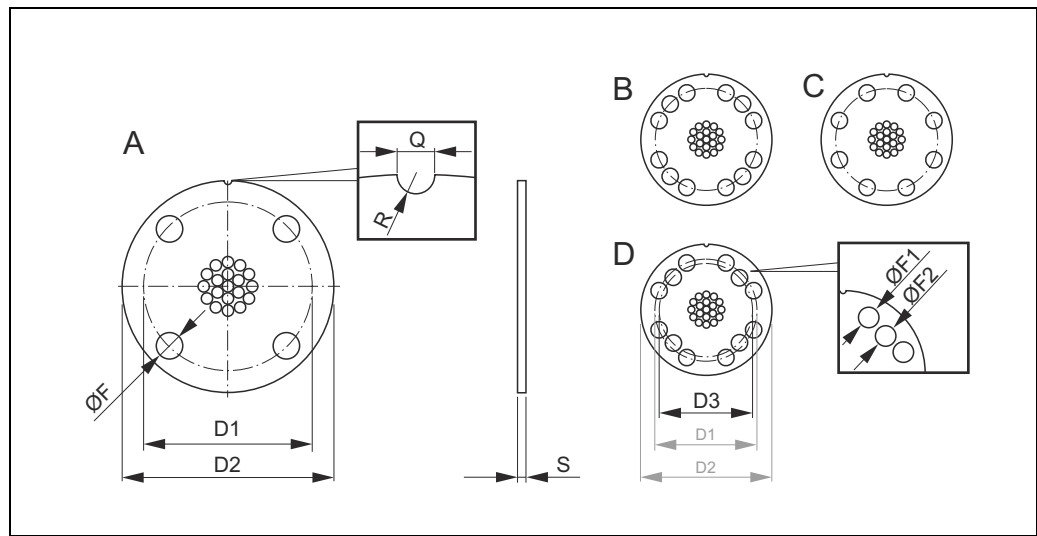

A0005166

DN	Type	D1	D2	F	Q	R	EN (DIN)			
							PN 16		PN 40	
							S	[kg]	S	[kg]
25	A	83	105	13	5	2.5	-	-	4.5	0.3
40	A	108	135	17	5	2.5	-	-	7.0	0.7
50	A	123	150	17	5	2.5	-	-	8.5	1.0
80	C	158	185	17	5	2.5	-	-	13.0	2.3
100	C	187	220	22	5	2.5	17.0	4.1	17.0	4.1

All dimensions in [mm]

DN	Type	D1	D2	F	Q	R	JIS 10K/20K			
							Sched 40		Sched 80	
							S	[kg]	S	[kg]
25	A	87	115	17	5	2.5	4.5	0.4	4.0	0.4
40	A	102	130	17	5	2.5	6.5	0.7	6.0	0.7
50	B	117	145	17	5	2.5	8.5	1.2	8.0	1.1
80	C	157	188	21	5	2.5	12.5	3.0	12.0	2.8
100	C	182	214	21	5	2.5	16.5	5.1	15.5	4.8

All dimensions in [mm]

DN	Type	D1	D2	D3	F	F1	F2	Q	R	ASME Cl. 150/300				
										Sched 40		Sched 80		
										S	[kg]	S	[kg]	
25	1"	A	85.5	110	-	19.0	-	-	5	2.5	4.5	0.4	4	0.4
40	1 1/2"	A	109.5	142	-	23.5	-	-	5	2.5	6.5	0.9	6	0.9
50	2"	D	127	150	120.7	17.0	-	-	5	2.5	8.5	1.3	8	1.3
80	3"	D	168.3	200	152.4	-	20.0	17	5	2.5	12.5	3.2	12	3.2
100	4"	C	197	230	-	23.5	-	-	5	2.5	16.5	5.3	15.5	5.3

All dimensions in [mm]

Hot tap, process pressure

Low-pressure and medium-pressure version

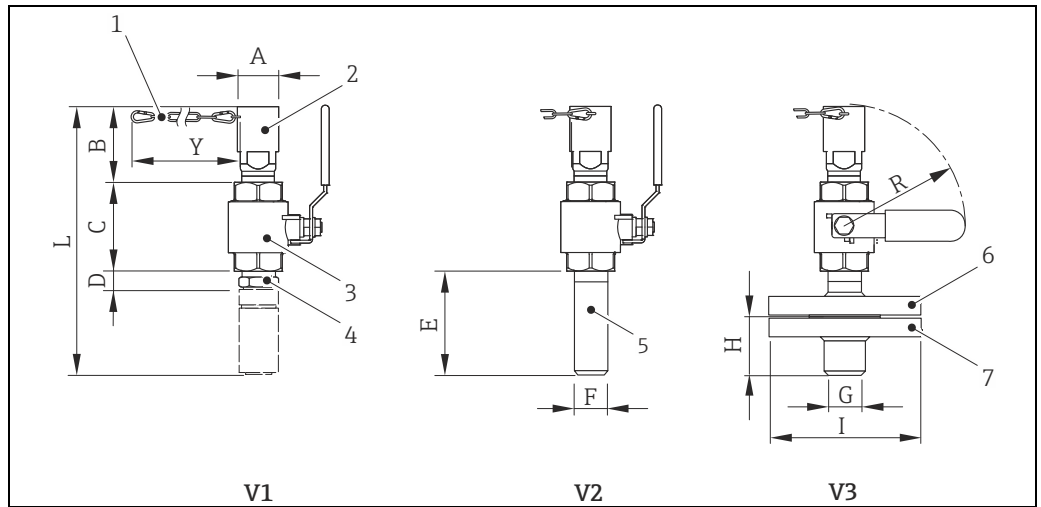

- 1 Safety chain for low-pressure version
- 2 Sensor connection
- 3 Ball valve
- 4 Retrofit adapter
- 5 Weld boss process connection
- 6 Flange adapter
- 7 Flange process connection
- V1 Version with retrofit adapter
- V2 Version with weld boss
- V3 Version with flange

L	A	B	C	D	E	F	G	H	I	R	Y
252.5	42.2	~85	88	60	123	33.4	33.4	54	123.9	165	620
All dimensions in [mm]											

V1	V2	V3
2.8	2.4	4.9
Weight in [kg]		

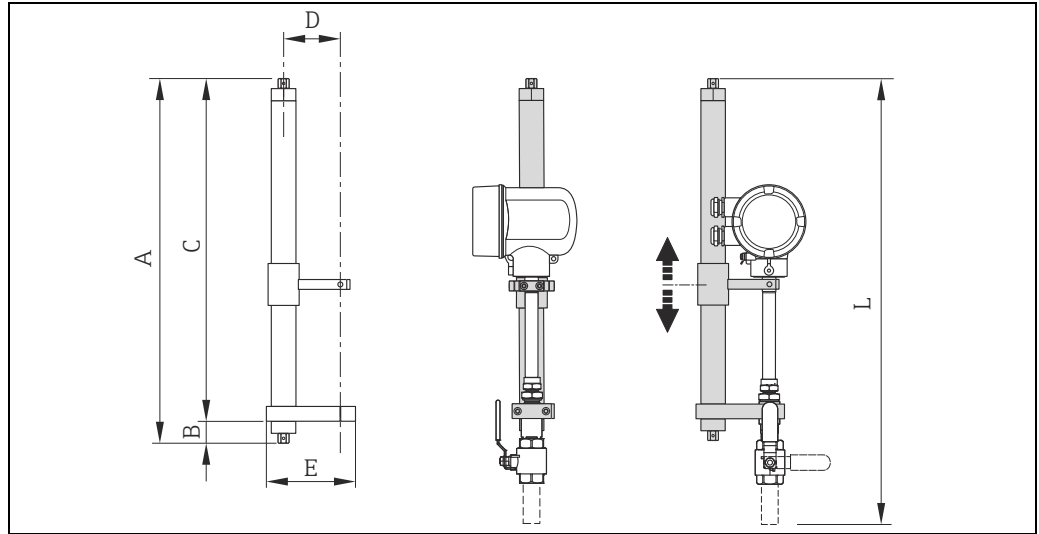

A0022055

Extractor assemblies for medium-pressure version

L	A	B	C	D	E	Weight
740	740	40	700	120	180	8.4
All dimensions in [mm], weight in [kg]						

Cold tap, atmospheric pressure

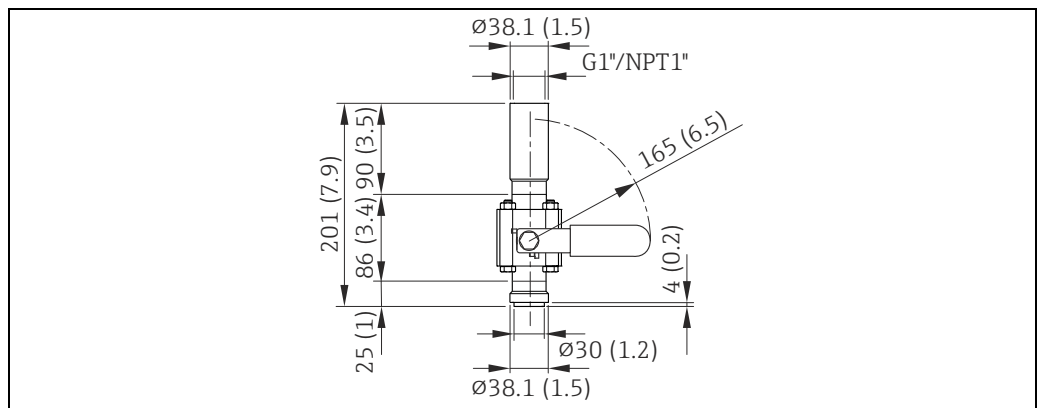

A0024413

Engineering unit mm (in)

Process connections in US units

t-mass 65F: Flange connections as per ASME

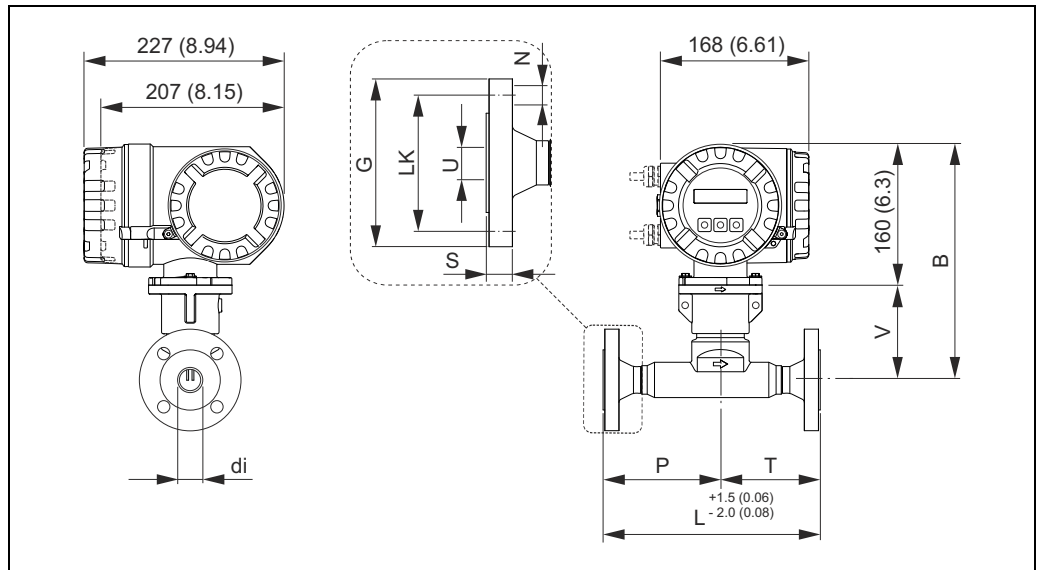

A0005162

Engineering unit mm (in)

Flange ASME B16.5 / Cl 150 / Sched 40: 1.4404/316L/316											
Surface roughness (flange): N9 / 250 μ m											
DN	d_i	B	G	L	LK	N	P	S	T	U	V
½"	0.55	10.9	3.50	9.65	2.38	4 × 0.62	5.22	0.44	4.43	0.62	4.41
1"	0.96	10.9	4.25	9.65	3.12	4 × 0.62	5.22	0.56	4.43	1.05	4.41
1 ½"	1.50	10.8	5.00	12.60	3.88	4 × 0.62	7.87	0.69	4.72	1.61	4.29
2"	1.94	10.9	6.00	15.75	4.75	4 × 0.75	9.84	0.75	5.91	2.07	4.65
3"	2.90	11.5	7.50	25.20	6.00	4 × 0.75	15.75	0.94	9.45	3.07	5.00
4"	3.82	11.9	9.00	31.50	7.50	8 × 0.75	19.70	0.96	11.79	4.03	5.47

All dimensions in [in]

Flange ASME B16.5 / Cl 150 / Sched 80: 1.4404/316L/316											
Surface roughness (flange): N9 / 250 μ m											
DN	d_i	B	G	L	LK	N	P	S	T	U	V
½"	0.55	10.9	3.50	9.65	2.38	4 × 0.62	5.22	0.44	4.43	0.55	4.41
1"	0.96	10.9	4.25	9.65	3.12	4 × 0.62	5.22	0.56	4.43	0.96	4.41
1 ½"	1.50	10.8	5.00	12.6	3.88	4 × 0.62	7.87	0.69	4.72	1.50	4.29
2"	1.94	10.9	6.00	15.7	4.75	4 × 0.75	9.84	0.75	5.91	1.94	4.65
3"	2.90	11.5	7.50	25.2	6.00	4 × 0.75	15.75	0.94	9.45	2.90	5.00
4"	3.82	11.9	9.00	31.5	7.50	8 × 0.75	19.70	0.96	11.79	3.82	5.47

All dimensions in [in]

Flange ASME B16.5 / Cl 300 / Sched 40: 1.4404/316L/316											
Surface roughness (flange): N9 / 250 µin											
DN	di	B	G	L	LK	N	P	S	T	U	V
½"	0.55	10.9	3.75	9.65	2.62	4 × 0.62	5.22	0.56	4.43	0.62	4.41
1"	0.96	10.9	4.88	9.65	3.50	4 × 0.75	5.22	0.69	4.43	1.05	4.41
1 ½"	1.50	10.8	6.12	12.6	4.50	4 × 0.88	7.87	0.81	4.72	1.61	4.29
2"	1.94	10.9	6.50	15.7	5.00	8 × 0.75	9.84	0.88	5.91	2.07	4.65
3"	2.90	11.5	8.25	25.2	6.62	8 × 0.88	15.75	1.12	9.45	3.07	5.00
4"	3.82	11.9	10.00	31.5	7.88	8 × 0.88	19.70	1.25	11.79	4.03	5.47
All dimensions in [in]											

Flange ASME B16.5 / Cl 300 / Sched 80: 1.4404/316L/316											
Surface roughness (flange): N9 / 250 µin											
DN	di	B	G	L	LK	N	P	S	T	U	V
½"	0.55	10.9	3.75	9.65	2.62	4 × 0.62	5.22	0.56	4.43	0.55	4.41
1"	0.96	10.9	4.88	9.65	3.50	4 × 0.75	5.22	0.69	4.43	0.96	4.41
1 ½"	1.50	10.8	6.12	12.6	4.50	4 × 0.88	7.87	0.81	4.72	1.50	4.29
2"	1.94	10.9	6.50	15.7	5.00	8 × 0.75	9.84	0.88	5.91	1.94	4.65
3"	2.90	11.5	8.25	25.2	6.62	8 × 0.88	15.75	1.12	9.45	2.90	5.00
4"	3.82	11.9	10.00	31.5	7.88	8 × 0.88	19.70	1.25	11.79	3.82	5.47
All dimensions in [in]											

t-mass 65I: Compact insertion version

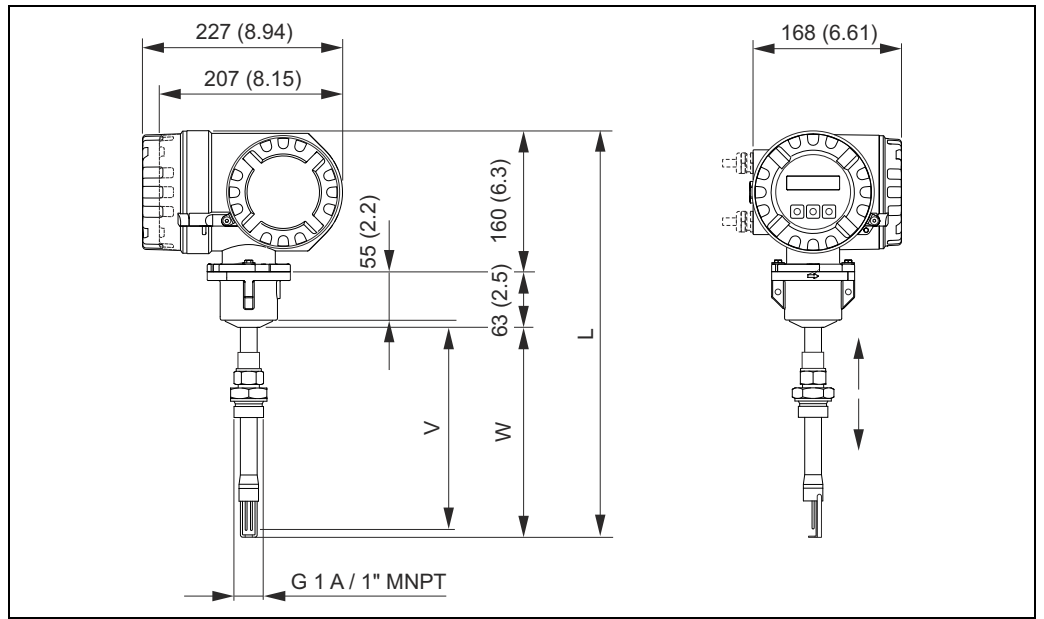

Engineering unit mm (in)

t-mass 65I: Remote sensor housing insertion version

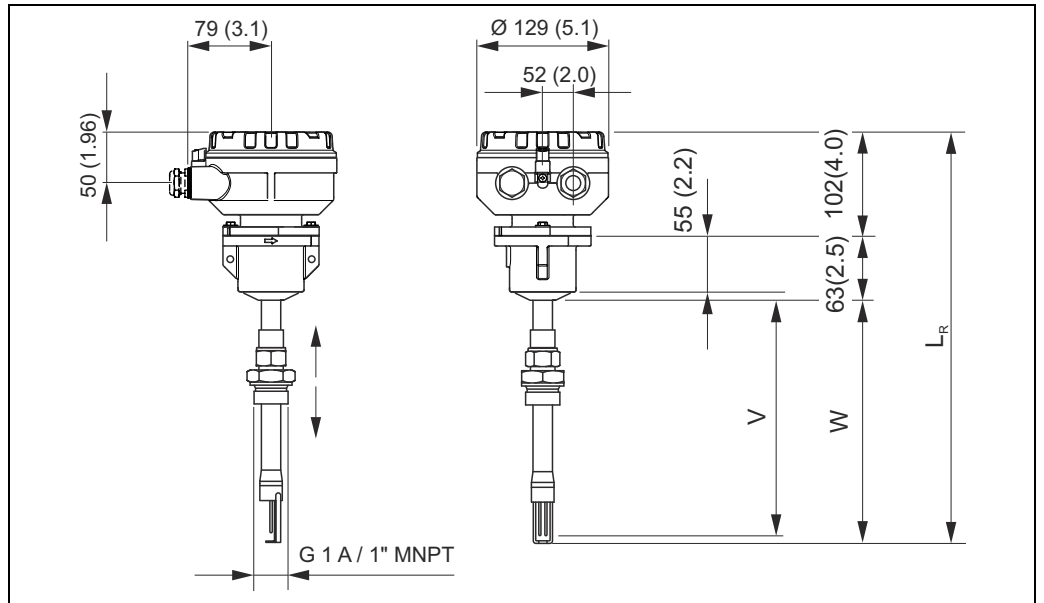

Engineering unit mm (in)

Length tmass 65I	V	W	L	L _R
9"	9.26	9.94	18.72	16.44
13"	13.19	13.88	22.66	20.38
17"	17.13	17.82	26.60	24.31
24"	23.94	24.63	33.41	31.13
All dimensions in [in]				

Flow conditioner according to ASME

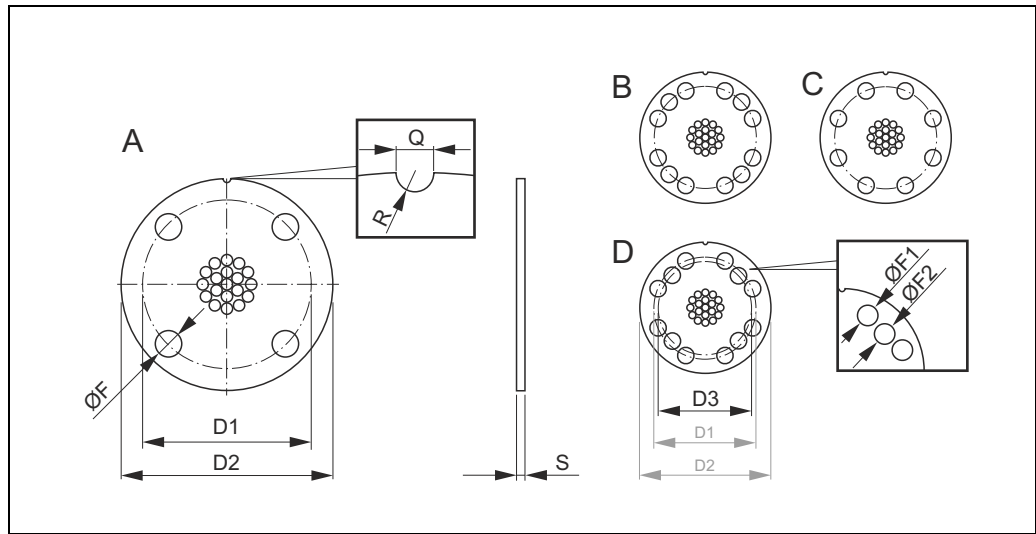

A0005166

DN	Type	D1	D2	D3	F	F1	F2	Q	R	ASME Cl. 150/300			
										Sched 40		Sched 80	
										S	[lbs]	S	[lbs]
1"	A	3.37	4.33	-	0.75	-	-	0.20	0.10	0.18	0.88	0.16	0.88
1 ½"	A	4.31	5.59	-	0.93	-	-	0.20	0.10	0.26	1.98	0.24	1.98
2"	D	5	5.91	4.75	0.67	-	-	0.20	0.10	0.33	2.86	0.31	2.86
3"	D	6.63	7.87	6	-	0.79	0.67	0.20	0.10	0.49	7.05	0.47	7.05
4"	C	7.76	9.06	-	0.93	-	-	0.20	0.10	0.65	11.68	0.61	11.68
All dimensions in [in]													

Hot tap, process pressure

Low-pressure and medium-pressure version

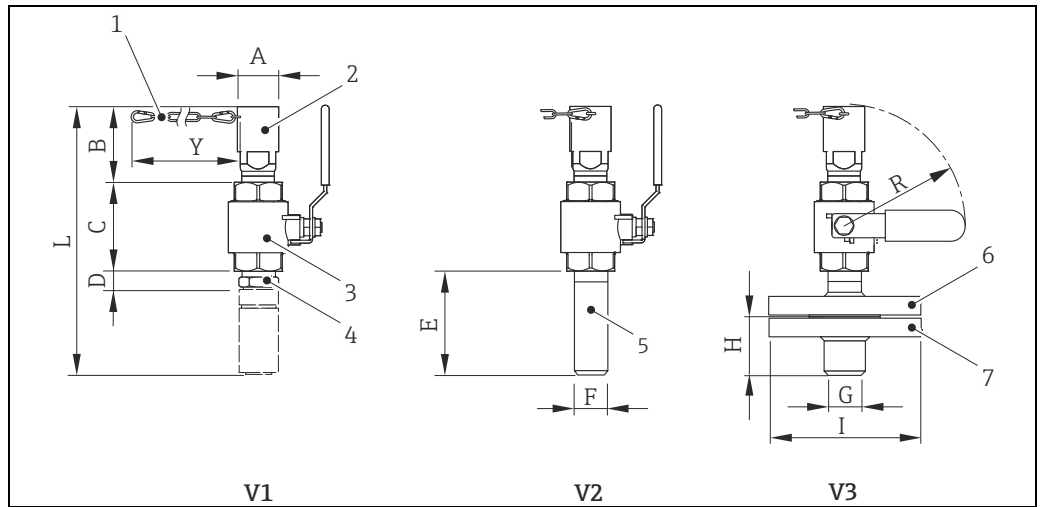

A0024284

- 1 Safety chain for low-pressure version
- 2 Sensor connection
- 3 Ball valve
- 4 Retrofit adapter
- 5 Weld boss process connection
- 6 Flange adapter
- 7 Flange process connection
- V1 Version with retrofit adapter
- V2 Version with weld boss
- V3 Version with flange

L	A	B	C	D	E	F	G	H	I	R	Y
9.94	1.66	~3.35	3.46	2.36	4.84	1.31	1.31	2.13	4.88	6.50	24.41

All dimensions in [in]

V1	V2	V3
6.17	5.29	10.80
Weight in [lbs]		

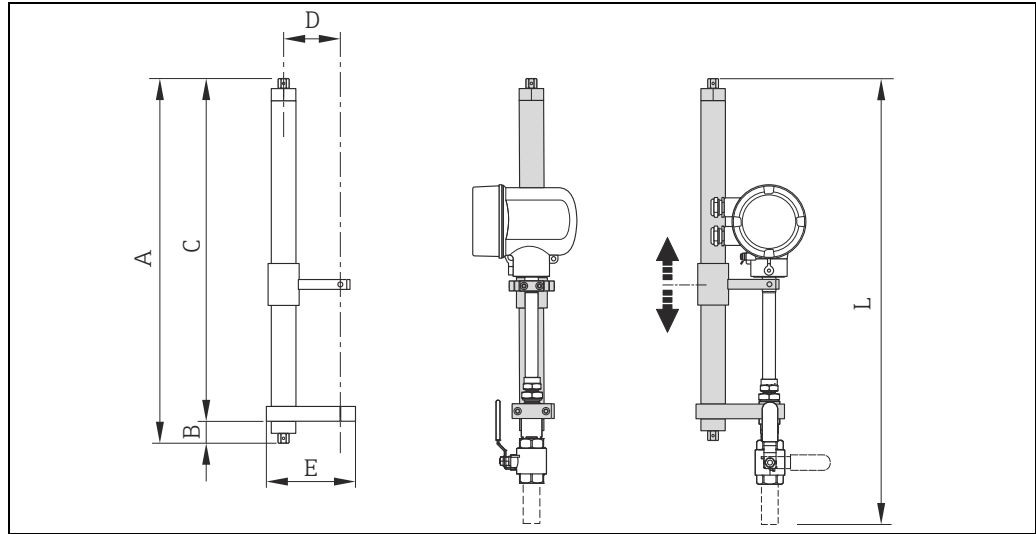

A0022055

Extractor assemblies for medium-pressure version

L	A	B	C	D	E	Weight
29.13	29.13	1.57	27.56	4.72	7.09	18.52

All dimensions in [in], weight in [lbs]

Cold tap, atmospheric pressure

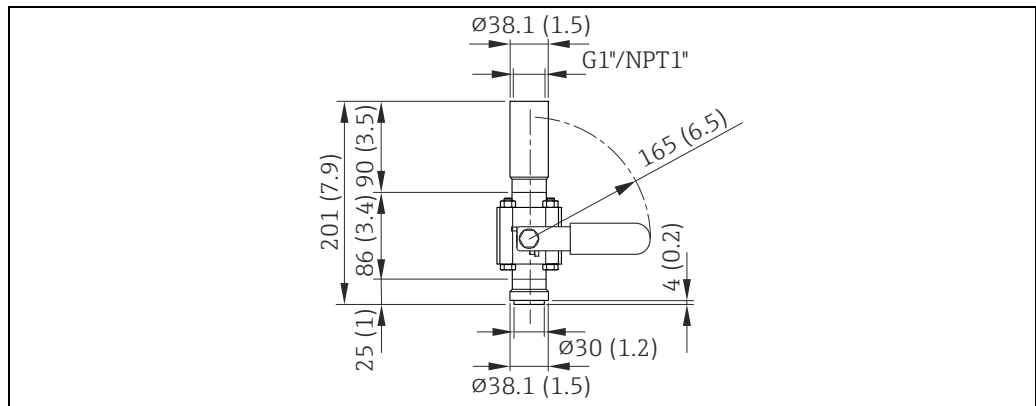

A0024413

Engineering unit mm (in)

Weight

- Remote version
- Wall-mount housing of remote version: 5 kg (11 lbs)
- Flow conditioner → [36](#), → [42](#)
- Hot tap, process pressure → [37](#), → [43](#)
- Cold tap, ambient pressure → [38](#), → [44](#)

Weight (SI units)

t-mass F* / DN	15	25	40	50	80	100
Compact version	7.5	8.0	12.5	12.5	18.7	27.9
Remote version	5.5	6.0	10.5	10.5	16.7	25.9

Weight dimensions in [kg]

* For flanged versions, all values (weight) refer to devices with EN/DIN PN 40 flanges.

t-mass I / sensor length	235	335	435	608
Compact version	6.4	6.6	7.0	7.4
Remote version	4.4	4.6	5.0	5.4

Weight dimensions in [kg]

* For flanged versions, all values (weight) refer to devices with EN/DIN PN 40 flanges.

Weight (US units)

t-mass F* / DN [in]	½"	1"	1½"	2"	3"	4"
Compact version	16.5	17.6	27.5	27.5	41.2	61.5
Remote version	12.1	13.2	23.1	23.1	36.7	57.1

Weight dimensions in [lbs]

* For flanged versions, all values (weight) refer to devices with CI 150 flanges.

t-mass I / sensor length [in]	9.25"	13.2"	17.1"	24.0"
Compact version	14.1	14.5	15.4	16.3
Remote version	9.7	10.1	11.0	11.9

Weight dimensions in [lbs]

* For flanged versions, all values (weight) refer to devices with CI 150 flanges.

Materials**Transmitter housing**

- Compact housing: powder coated die-cast aluminum
- Wall-mount housing: powder coated die-cast aluminum
- Remote field housing: powder coated die-cast aluminum

Connection housing, sensor (remote version)

Powder coated die-cast aluminum

t-mass F sensor

Measuring tube:

- Wetted parts:
 - DN 15 to 25 (½ to 1"): stainless cast steel CF3M-A351
 - DN 40 to 100 (1 ½ to 4"): 1.4404 (316/316L)
- Non-wetted parts:
 - 1.4301 (304)

Flanges (process connections):

Stainless steel 1.4404 (316L/316)

Transducer:

- 1.4404 (316L)
- Alloy C22, 2.4602 (N06022)

Transducer elements:

- 1.4404 (316L) or
- 1.4404 (316L)
- Alloy C22, 2.4602 (N06022)

Bushing:

PEEK GF30, PVDF (TSP on request)

O-rings:

EPDM, Kalrez 6375, Viton FKM

t-mass I sensor

Insertion tube:

- Sensor length 235 (9"), 335 (13"), 435 (17"), 608 (24")
- 1.4404 (316/316L)
- Special lengths and full Alloy C22 versions on request

Transducer:

- 1.4404 (316L)
- Alloy C22, 2.4602 (N06022)

Protection guard:

1.4404 (316L)

Compression fitting:

1.4404 (316/316L)

Ferrule:

PEEK 450G, PVDF (on request)

Bonded seals:

EPDM, Kalrez 6375, Nitrile and 316/316L (outer ring)

Hot tap, process pressure

Lower tube section:

1.4404 (316/316L)

Upper tube section:

1.4404 (316/316L)

Ball valve:

CF3M and CF8M

Seal:

PTFE

Cold tap, atmospheric pressure

Lower tube section:

1.4404 to EN 10272 and 316/316L to A479

Upper tube section:

1.4404 to EN 10216-5 and 316/316L to A312

Ball valve:

CF3M and CF8M

Seal:

PTFE

Process connection

For both the flanged and insertion meters it is possible to have wetted parts degreased for oxygen service. Contact your Endress+Hauser sales center for more information.

t-mass F:

Flanges according EN 1092-1, JIS B2220 and ASME B16.5

t-mass I:



G 1A or 1" MNPT thread

Operability

Display elements	<ul style="list-style-type: none"> ▪ Liquid crystal display: illuminated, two lines with 16 characters per line ▪ Selectable display of different measured values and status variables ▪ At ambient temperatures below -20 °C (-4 °F) the readability of the display may be impaired.
Operating elements	<ul style="list-style-type: none"> ▪ Local operation with three keys (◀, ▶, ⏏) ▪ Quick Setup menus for straight forward commissioning
Languages	English, German, French, Spanish, Italian, Dutch, Norwegian, Finnish, Swedish, Portuguese, Polish, Czech
Remote operation	Operation via HART, PROFIBUS PA/DP, FOUNDATION Fieldbus, Modbus RS485

Certificates and approvals

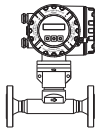
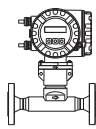
CE mark	The measuring device is in conformity with the statutory requirements of the applicable EC Directives. These are listed in the corresponding EC Declaration of Conformity along with the standards applied. Endress+Hauser confirms successful testing of the device by affixing to it the CE mark.
C-Tick mark	The measuring device meets the EMC requirements of the Australian Communications and Media Authority (ACMA).
Ex approval	Information about currently available Ex versions (ATEX, FM, CSA etc.) can be supplied by your Endress+Hauser sales center on request. All explosion protection data are given in a separate documentation which is available upon request.

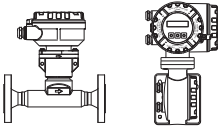
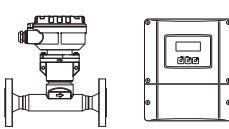
Explosionsgefährdeter Bereich		Sicherer Bereich
II2GD / Cl. 1 Div. 1	II3G / Cl. 1 Div. 2	
		
		

Example of t-mass devices in the hazardous area (Example t-mass 65F)

FOUNDATION Fieldbus certification	<p>The flowmeter has passed all the test procedures implemented and has been certified and registered by the Fieldbus Foundation. The flowmeter thus meets all the requirements of the specifications listed below:</p> <ul style="list-style-type: none"> ▪ Certified to FOUNDATION Fieldbus specification ▪ The flowmeter meets all the specifications of the FOUNDATION Fieldbus-H1. ▪ Interoperability Test Kit (ITK), revision status 5.01 (Certification on request) ▪ The device can also be operated in conjunction with other-make certified devices. ▪ Physical Layer Conformance Test of the Fieldbus Foundation
--	--

PROFIBUS DP/PA certification	<p>The flow device has successfully passed all the test procedures carried out and is certified and registered by the PNO (PROFIBUS User Organization). The device thus meets all the requirements of the following specifications: The device can also be operated with certified devices of other manufacturers (interoperability)</p>
Modbus RS485 certification	<p>The measuring device meets all the requirements of the MODBUS/TCP conformity and integration test and has the "MODBUS/TCP Conformance Test Policy, Version 2.0". The measuring device has successfully passed all the test procedures carried out and is certified by the "MODBUS/TCP Conformance Test Laboratory" of the University of Michigan.</p>
Pressure measuring device approval	<ul style="list-style-type: none"> ■ With the identification PED/G1/x (x = category) on the sensor nameplate, Endress+Hauser confirms conformity with the "Essential Safety Requirements" of Annex I of the Pressure Equipment Directive 97/23/EC. ■ Devices with this identification (with PED) are suitable for the following types of fluid: Fluids of Group 1 and 2 with a steam pressure of greater than, or smaller and equal to 0.5 bar (7.3 psi). ■ Devices without this identification (without PED) are designed and manufactured according to good engineering practice. They correspond to the requirements of Art. 3, Section 3 of the Pressure Equipment Directive 97/23/EC. Their application is illustrated in Diagrams 6 to 9 in Appendix II of the Pressure Equipment Directive 97/23/EC.
Oxygen service	<p>For oxygen applications with the order code for "Surface cleaning" option B "Certified and cleaned of oil and grease" We certify that the wetted parts of the flow sensor have been degreased in accordance with British Oxygen Company (BOC) specification 50000810 and BS-IEC-60877:1999. After final degreasing there shall be less than 100 milligram/m² (0.01 milligram/cm²) of oil/grease contamination on the degreased surface of the component.</p>
Other standards and guidelines	<p>BS IEC 60877:1999 Procedures for ensuring the cleanliness of industrial-process measurement and control equipment in oxygen service.</p> <p>EN 60529 Degrees of protection by housing (IP code)</p> <p>EN 61010-1 Protection Measures for Electrical Equipment for Measurement, Control, Regulation and Laboratory Procedures.</p> <p>EN 91/155/EEC Safety Data Sheets Directive.</p> <p>IEC/EN 61326 "Emission in accordance with requirements for Class A". Electromagnetic compatibility (EMC-requirements).</p> <p>ISO 14511 Measurement of fluid flow in closed conduits - Thermal mass flowmeters.</p> <p>ISO/IEC 17025 General requirements for the competence of testing and calibration laboratories.</p> <p>NAMUR NE 21 Electromagnetic compatibility (EMC) of industrial process and laboratory control equipment.</p> <p>NAMUR NE 43 Standardization of the signal level for the breakdown information of digital transmitters with analogue output signal.</p> <p>NAMUR NE 53 Software of field devices and signal-processing devices with digital electronics</p>

Ordering information

The Endress +Hauser sales center can provide detailed ordering information and information on the extended order code.

To ensure each meter is programmed to individual requirements, the following information is essential:

- Gas type if not air (composition if more than one gas in % Mole)
- Gas pressure
- Gas temperature
- Line size - internal diameter in metric or US units
- 20 mA range required
- Flow engineering units (kg/h etc.)

Accessories

The Endress +Hauser sales center can provide detailed information on request.

Device-specific accessories

Accessories	Description	Order code
Mounting boss	Mounting boss for the t-mass insertion version	DK6MB - *
Cable remote version	Connecting cable for the remote version	DK6CA - *
Mounting set for transmitter	Mounting set for remote version. Suitable for: <ul style="list-style-type: none"> - Wall mounting - Pipe mounting - Installation in control panel Mounting set for aluminum field housing: Suitable for pipe mounting (¾" to 3")	DK6WM - *
Hot tap, process pressure	Low-pressure version: Mounting kit with process connection, ball valve, safety chain and sensor connection. Insertion or extraction of sensor under process pressure (max. 4.5 barg (65 psig)).	DK6HT-***
	Medium-pressure version: Mounting kit with process connection, ball valve, sensor connection and extractor assembly. Insertion or extraction of sensor under process pressure (max. 16 barg (235 psig)).	
Cold tap, atmospheric pressure	Mounting kit with sensor connection, ball valve and weld boss. Insertion or extraction of sensor in unpressurized pipes (ambient pressure). In the absence of a measuring device, the mounting kit enables pipe resealing in order to resume the process.	DK6ML-***
Flow conditioner	<ul style="list-style-type: none"> ■ t-mass F: DN25 to 100 (1 to 4") ■ t-mass I: DN80 to 300 (3 to 12") 	DK6ST-*** DK7ST-***
Graphic data manager Memograph M	The graphic data manager Memograph M provides information on all the relevant process variables. Measured values are recorded correctly, limit values are monitored and measuring points analyzed. The data are stored in the 256 MB internal memory and also on an SD card or USB stick. The mathematics channels which are optionally available enable continuous monitoring of specific power consumption, boiler efficiency and other parameters which are necessary for efficient energy management.	RSG40 - *****

Communication-specific accessories

Accessories	Description	Order code
HART Communicator Field Xpert SFX 100	Handheld terminal for remote configuration and for obtaining measured values via the 4 to 20 mA HART current output. Further information is available from your Endress+Hauser sales center.	SFX100 - *****

Service-specific accessories

Accessories	Description	Order code
Applicator	<p>Software for selecting and sizing Endress+Hauser measuring devices:</p> <ul style="list-style-type: none"> ▪ Calculation of all the necessary data for identifying the optimum flowmeter: e.g. nominal diameter, pressure loss, accuracy or process connections ▪ Graphic illustration of the calculation results <p>Administration, documentation and access to all project-related data and parameters over the entire life cycle of a project.</p> <p>Applicator is available:</p> <ul style="list-style-type: none"> ▪ Via the Internet: https://wapps.endress.com/applicator ▪ On CD-ROM for local PC installation. 	DKA80 - *
FieldCare	FieldCare is Endress+Hauser's FDT based Plant Asset Management Tool. It can configure all intelligent field devices in your plant and supports you in managing them. By using status information, it also provides a simple but effective means of checking their health.	Please refer to the product page of the Endress+Hauser Internet page: www.endress.com
Fieldcheck	Tester/simulator for testing flowmeters in the field. When used in conjunction with the "FieldCare" software package, test results can be imported into a database, printed and used for official certification. Further information is available from your Endress+Hauser sales center.	50098801
FXA193	The FXA193 service interface connects the device to the PC for configuration via FieldCare.	FXA193 - *

Documentation

- Flow measuring technology (FA00005D)
- Technical Information (TI00069D/06)
- Operating Instructions HART (BA00111D/06)
- Operating Instructions PROFIBUS DP (BA00113D/06)
- Operating Instructions Modbus (BA00115D/06)
- Description of Device Functions HART (BA00112D/06)
- Description of Device Functions PROFIBUS DP (BA00114D/06)
- Description of Device Functions Modbus (BA00116D/06)
- Supplementary documentation on Ex-ratings: ATEX, FM, CSA, IECEx NEPSI

Registered trademarks

KALREZ® and VITON®

Registered trademarks of DuPont Performance Elastomers L.L.C., Wilmington, USA

AMS™

Registered trademark of Emerson Process Management, St. Louis, USA

HART®

Registered trademark of HART Communication Foundation, Austin, USA

PROFIBUS®

Registered trademark of the PROFIBUS User Organization, Karlsruhe, Germany

FOUNDATION™ Fieldbus

Registration-pending trademark of the Fieldbus Foundation, Austin, Texas, USA

Modbus®

Registered trademark of SCHNEIDER AUTOMATION, INC.

HistoROM™, S-DAT®, T-DAT™, F-CHIP®, FieldCare®, Field Xpert™, Fieldcheck®,

Applicator®, t-mass®

Registered or registration-pending trademarks of businesses in the Endress+Hauser Group

www.addresses.endress.com
