



Level



Pressure



Flow



Temperature

Liquid
Analysis

Registration

Systems
Components

Services



Solutions

Technical Information

iTEMP[®] TMT162

Dual input temperature field transmitter
with HART[®], FOUNDATION Fieldbus[™] or
PROFIBUS[®] PA protocol



Application

- Universal input usable for resistance thermometer (RTD), thermocouple (TC), resistance transmitter (Ω), voltage transmitter (mV)
- Output:
 - HART[®] protocol for converting various input signals to a scalable 4 to 20 mA analog output signal. Operating the transmitter using handheld terminals Field Xpert SFX100, DXR275/375/475 or remotely via PC
 - FOUNDATION Fieldbus[™] ITK 5.2.0
 - PROFIBUS[®] PA Profile 3.02
- Optional: stainless steel housing for hygienic or Ex d application

Features and benefits

- High reliability in harsh industrial environments due to dual compartment housing and compact, fully potted electronics
- Backlit display with large measured value, bargraph and status condition indication

- Ability to display measured values other devices (FOUNDATION Fieldbus[™]: up to 5; PROFIBUS[®] PA: 1)
- Dual sensor input capability, e.g. 2 Pt100 3-wire or 1 Pt100 4-wire and thermocouple
- Diagnostics information according to NAMUR NE107
- Reliable operation due to sensor monitoring: breakdown information, sensor backup, drift alarm and corrosion detection
- High measuring point accuracy due to sensor transmitter matching
- Operation voltage monitoring for high measurement reliability (HART[®])
- Mathematic functions for differential and average temperature add flexibility to the measurement
- FISCO/FNICO compliant according to IEC 60079-27
- International approvals guarantee safe operation in hazardous area: FM, CSA (IS, NI, XP and DIP) and ATEX (Ex ia, Ex nA nL, Ex d and dust-Ex)
- Galvanic isolation 2 kV (sensor input to the output)

Function and system design

Measuring principle

Electronic monitoring, conversion and display of input signals in industrial temperature measurement.

Measuring system

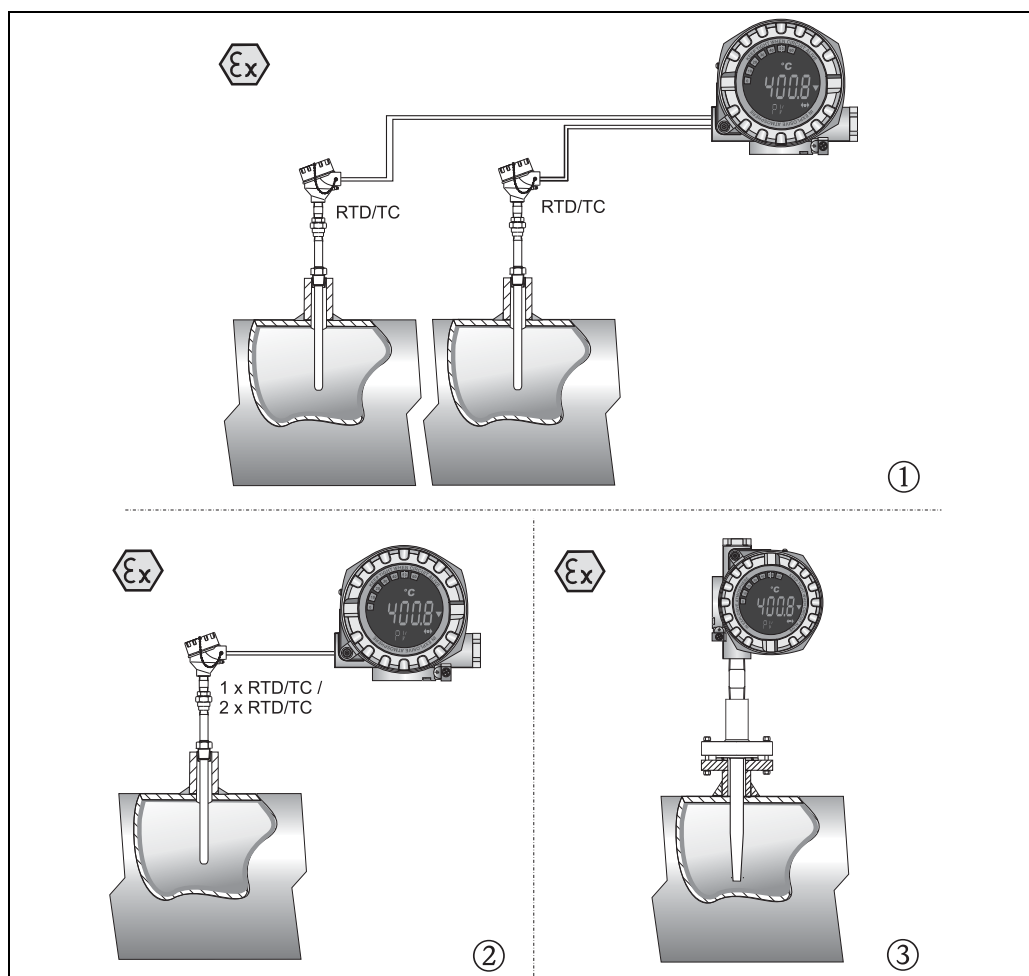

Examples of applications

- ① Two sensors with measuring input (RTD or TC) in remote installation with the advantages: drift alert, sensor backup function and temperature dependent sensor switch
- ② 1 x RTD/TC or 2 x RTD/TC as redundancy
- ③ Temperature field transmitter in combination with a sensing element, insert and thermowell as compact thermometer

The iTEMP® temperature field transmitter TMT162 is a two-wire transmitter with an analog output or fieldbus protocol, two (optional) measuring inputs for resistance thermometers and resistance transmitters in 2, 3 or 4-wire connection (for a resistance measuring input), thermocouples and voltage transmitters. The LC display shows the current measured value digitally and as a bar graph. The current device status is also shown on the display.

Standard diagnostic functions

- Cable open-circuit, short-circuit
- Incorrect wiring
- Internal device errors
- Overrange/underrange detection
- Ambient temperature out-of-range detection

Corrosion detection according to NAMUR NE89

Corrosion of the sensor connections can lead to corruption of the measured value. The field transmitter offers the option of detecting corrosion on thermocouples and resistance thermometers with a 4-wire connection before measured value corruption occurs. The transmitter avoids false measured readings and is also able to indicate a warning on the display as well as through HART® or Fieldbus protocol when wire resistance exceeds reasonable values.

Low voltage detection for HART® communication

The low voltage detection prevents the device from continuously outputting an incorrect analog output value (i.e. due to damaged or incorrect power supply or due to a damaged signal cable). If the required supply voltage is undershot, the analog output value drops < 3.6 mA for approx. 3 s. An error message appears on the display. Afterwards the device tries to output the normal analog output value again. If the supply voltage is still too low, the analog output value drops again to < 3.6 mA.

Optional 2-channel functions

These functions increase the reliability and availability of the process values:

- Sensor backup: If sensor 1 fails, the output signal is switched without interruption to the measured value of sensor 2.
- Temperature-dependent sensor switchover: The measured value is measured by sensor 1 or 2 depending on the process temperature.
- Sensor drift detection: If the two measured values of sensor 1 and 2 deviate from a predefined value, a drift warning or alarm is output.

Equipment architecture

Analog current output 4 to 20 mA with HART®-Protocol

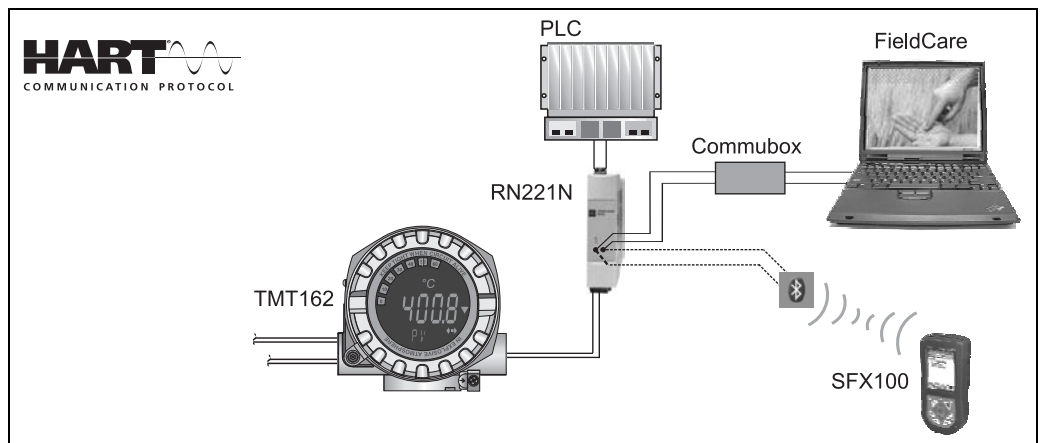

A0014375

System integration via FOUNDATION Fieldbus™

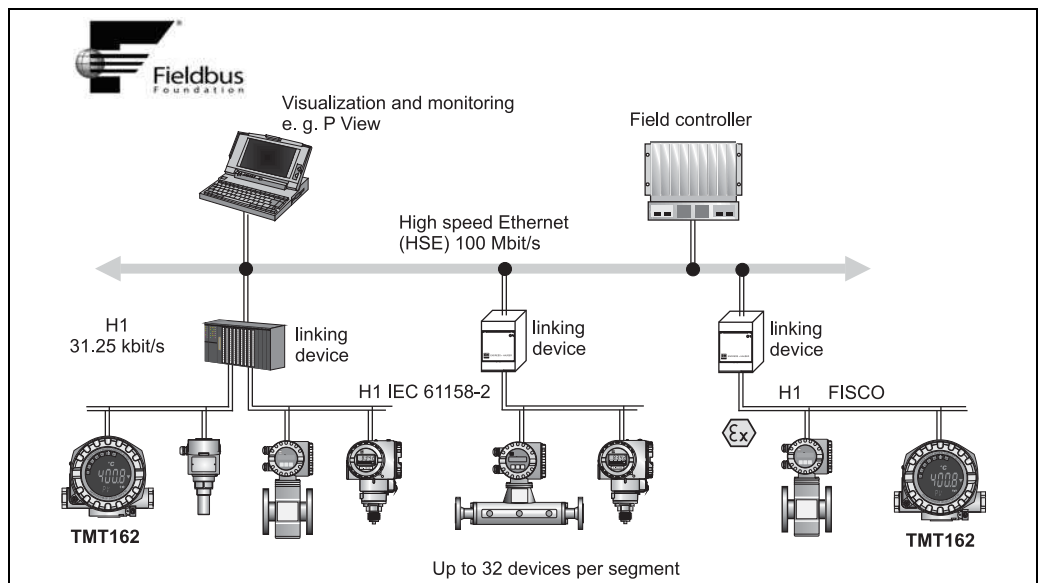

T09-TMT162Z2-14-00-xx-en-004

System integration via PROFIBUS® PA

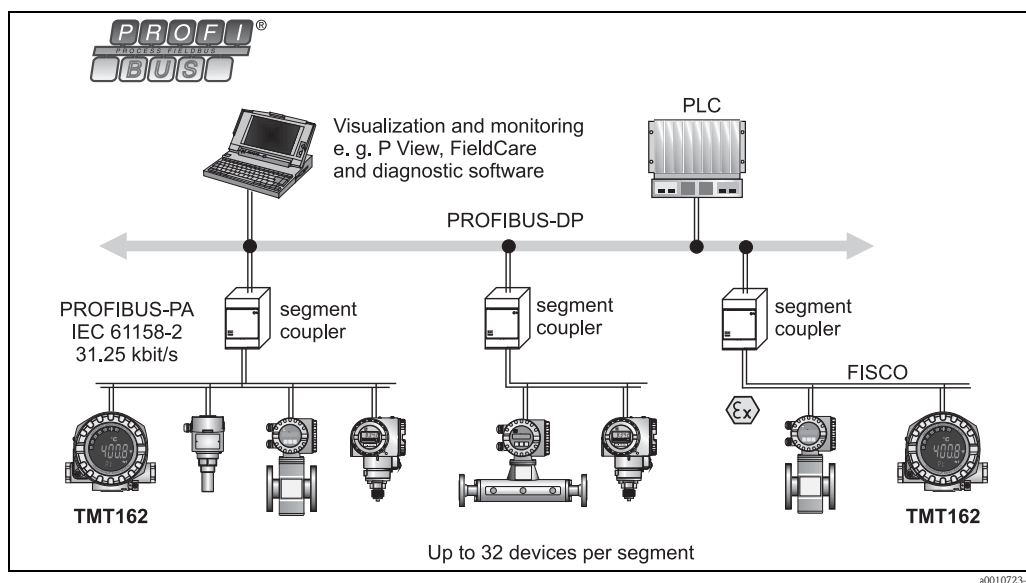

Input

Measured variable

Temperature (temperature linear transmission behaviour), resistance and voltage.

Measuring range

Type of input	Designation	Measuring range limits	Min. span
Resistance thermometer (RTD) to IEC 60751 ($\alpha = 0.00385$) to JIS C1604-81 ($\alpha = 0.003916$) to DIN 43760 ($\alpha = 0.006180$) to Edison Copper Winding No.15 ($\alpha = 0.004274$) to Edison Curve ($\alpha = 0.006720$) to GOST ($\alpha = 0.003911$) to GOST ($\alpha = 0.004280$)	Pt100	-200 to 850 °C (-328 to 1562 °F)	10 °C (18 °F)
	Pt200	-200 to 850 °C (-328 to 1562 °F)	10 °C (18 °F)
	Pt500	-200 to 250 °C (-328 to 482 °F)	10 °C (18 °F)
	Pt1000	-200 to 250 °C (-328 to 482 °F)	10 °C (18 °F)
	Pt100	-200 to 649 °C (-328 to 1200 °F)	10 °C (18 °F)
	Ni100	-60 to 250 °C (-76 to 482 °F)	10 °C (18 °F)
	Ni1000	-60 to 150 °C (-76 to 302 °F)	10 °C (18 °F)
	Cu10	-100 to 260 °C (-148 to 500 °F)	10 °C (18 °F)
	Ni120	-70 to 270 °C (-94 to 518 °F)	10 °C (18 °F)
	Pt50	-200 to 1100 °C (-328 to 2012 °F)	10 °C (18 °F)
Pt100	-200 to 850 °C (-328 to 1562 °F)	10 °C (18 °F)	
Cu50, Cu100	-200 to 200 °C (-328 to 392 °F)	10 °C (18 °F)	
Pt100 (Callendar - van Dusen)	10 to 400 Ω 10 to 2000 Ω	10 Ω 100 Ω	
Nickel polynomial (not for HART® protocol)	10 to 400 Ω 10 to 2000 Ω	10 Ω 100 Ω	
Copper polynomial (not for HART® protocol)	10 to 400 Ω 10 to 2000 Ω	10 Ω 100 Ω	
	<ul style="list-style-type: none"> ■ Type of connection: 2-wire, 3-wire or 4-wire connection, sensor current: ≤ 0.3 mA ■ With 2-wire circuit, compensation of wire resistance possible (0 to 30 Ω) ■ With 3-wire and 4-wire connection, sensor wire resistance to max. 50 Ω per wire 		
Resistance transmitter	Resistance Ω	10 to 400 Ω 10 to 2000 Ω	10 Ω 100 Ω

Type of input	Designation	Measuring range limits	Min. span
Thermocouples (TC) to IEC 584 part 1	Type B (PtRh30-PtRh6) ^{1) 2)}	+40 to +1820 °C (+104 to +3308 °F)	500 °C (900 °F)
	Type E (NiCr-CuNi)	-270 to +1000 °C (-454 to +1832 °F)	50 °C (90 °F)
	Type J (Fe-CuNi)	-210 to +1200 °C (-346 to +2192 °F)	50 °C (90 °F)
to ASTM E988	Type K (NiCr-Ni)	-270 to +1372 °C (-454 to +2501 °F)	50 °C (90 °F)
	Type N (NiCrSi-NiSi)	-270 to +1300 °C (-454 to +2372 °F)	50 °C (90 °F)
	Type R (PtRh13-Pt)	-50 to +1768 °C (-58 to +3214 °F)	500 °C (900 °F)
	Type S (PtRh10-Pt)	-50 to +1768 °C (-58 to +3214 °F)	500 °C (900 °F)
	Type T (Cu-CuNi)	-260 to +400 °C (-436 to +752 °F)	50 °C (90 °F)
to DIN 43710	Type C (W5Re-W26Re)	0 to +2315 °C (32 to +4199 °F)	500 °C (900 °F)
	Type D (W3Re-W25Re)	0 to +2315 °C (32 to +4199 °F)	500 °C (900 °F)
	Type L (Fe-CuNi)	-200 to +900 °C (-328 to 1652 °F)	50 °C (90 °F)
	Type U (Cu-CuNi)	-200 to +600 °C (-328 to 1112 °F)	50 °C (90 °F)
	<ul style="list-style-type: none"> ■ Internal cold junction (Pt100) ■ External cold junction: configurable value -40 to +85 °C (-40 to +185 °F) ■ Max. sensor resistance 10 kΩ (if sensor resistance is greater than 10 kΩ, error message as per NAMUR NE89)³⁾ 		
Voltage transmitter (mV)	Millivolt transmitter (mV)	-20 to 100 mV	5 mV

- 1) Significant measuring inaccuracy for temperatures lower than 300 °C (572 °F).
- 2) When operating conditions are based on a large temperature range, the TMT162 offers the ability to split the range. For example, a Type S or R thermocouple can be used for the low range and a Type B can be used for the upper range. The TMT162 is then programmed to switch at a predetermined temperature. This allows for utilization of the best performance from each individual thermocouple and provides 1 output that represents the process temperature. Note: the dual sensor option must be included in the order code for the HART[®] protocol. Two sensor inputs are already provided as standard if the FF and PA protocol are selected.
- 3) Basic requirements NE89: detection of increased sensor resistance (e.g. corrosion of contacts or wires) of TC or RTD/4-wire.

Output

Output signal

HART[®]	
Analog output	4 to 20 mA, 20 to 4 mA
Signal encoding	FSK ± 0.5 mA via current signal
Data transmission rate	1200 baud
Galvanic isolation	U = 2 kV AC (input/output)

FOUNDATION Fieldbus[™]	
Signal encoding	FOUNDATION Fieldbus [™] H1, IEC 61158-2, Manchester Bus Powered (MBP)
Data transmission rate	31.25 kBit/s, voltage mode
Galvanic isolation	U = 2 kV AC (input/output)

PROFIBUS[®] PA	
Signal encoding	PROFIBUS [®] PA as per EN 50170 volume 2, IEC 61158-2, Manchester Bus Powered (MBP)
Data transmission rate	31.25 kBit/s, voltage mode
Galvanic isolation	U = 2 kV AC (input/output)

Breakdown information

HART®	
Breakdown information to NAMUR NE43: The information is created when the measuring information is invalid or not present anymore and gives a complete listing of all errors occurring in the measuring system.	
Under ranging	linear drop from 4.0 to 3.8 mA
Over ranging	linear rise from 20.0 to 20.5 mA
Failure, e. g. sensor break; sensor short circuit	≤ 3.6 mA ("low") or 21 mA ("high") can be selected ¹⁾

- 1) The high alarm is adjustable between 21.6 mA and 23 mA allowing for flexibility when working with the requirements of most control systems.

FOUNDATION Fieldbus™
Status message according to specification FOUNDATION Fieldbus™.

PROFIBUS® PA
Status and alarms according to specification PROFIBUS® PA Profile 3.01/3.02

Load (HART®)

$$R_{b \max.} = (U_{b \max.} - 11 \text{ V}) / 0.023 \text{ A (current output)}$$

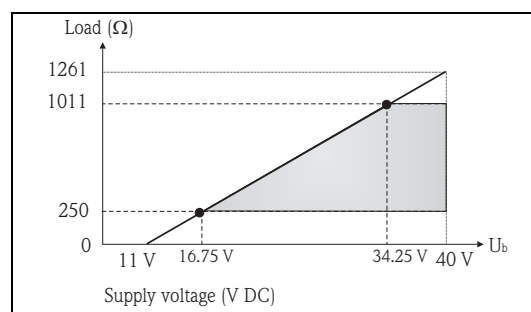

A0010971-EN

Linearization/transmission behavior

Temperature linear, resistance linear, voltage linear

Filter

1st order digital filter: 0 to 60 s

Current consumption

HART®	
Current consumption	3.6 mA to 23 mA Min. current consumption ≤ 3.5 mA Current limit ≤ 23 mA

FOUNDATION Fieldbus™	
Current consumption (device basic current)	≤ 11 mA
Switch-on current (device inrush current)	≤ 11 mA
Error current FDE (Fault Disconnection Electronic)	0 mA

PROFIBUS® PA	
Current consumption (device basic current)	≤ 11 mA
Error current FDE (Fault Disconnection Electronic)	0 mA

Protocol-specific data

HART®	
Version	5
Device address in multi-drop mode	Software setting
Write lock	Write lock activated by hardware or software setting
Device description files (DD)	Information and files available free of charge online at: www.endress.com www.hartcom.org
Load (communication resistance)	Min. 250 Ω

FOUNDATION Fieldbus™	
Supported functions	Instantiation of function blocks. The following methods are supported: <ul style="list-style-type: none"> ■ Quick Setup ■ User sensor trim ■ Factory trim settings ■ Callendar Van Dusen ■ Linearization polynomial nickel/copper ■ Sensor drift monitoring Refer to the relevant Operating Instructions for detailed descriptions.
Basic data	
Manufacturer ID	452B48 (Endress+Hauser)
Device type	10CC (Hex)
Device or bus address	247 (default)
Device revision	02 (hex)
ITK version	5.2.0
ITK certification driver no.	IT070400
Link Master functionality supported (LAS)	Yes
Link Master/Basic Device selectable	Yes; factory setting: Basic Device
Virtual Communication Relationship (VCRs)	
Number of VCRs	44
Number of link objects in VFD	50
Permanent entries	44
Client VCRs	0
Server VCRs	5
Source VCRs	8
Sink VCRs	0
Subscriber VCRs	12
Publisher VCRs	19
Link settings	
Slot time	4
Min. Inter PDU delay	12
Max. response delay	40

FOUNDATION Fieldbus™		
Blocks		
Block description	Execution time (macro cycle ≤ 500 ms)	Block class
Resource Block	Permanent	Extended
Transducer Block Sensor 1	Pre-instantiated	Manufacturer-specific
Transducer Block Sensor 2	Pre-instantiated	Manufacturer-specific
Transducer Block Display	Pre-instantiated	Manufacturer-specific
Transducer Block Adv. Diag.	Pre-instantiated	Manufacturer-specific
Function Block AI1	35 ms (pre-instantiated)	Extended
Function Block AI2	35 ms (pre-instantiated)	Extended
Function Block AI3	35 ms (pre-instantiated)	Extended
Function Block AI4	35 ms (not instantiated)	Extended
Function Block AI5	35 ms (not instantiated)	Extended
Function Block AI6	35 ms (not instantiated)	Extended
Function Block PID	50 ms	Standard
Function Block ISEL	30 ms	Standard
Short description of blocks		
Resource Block	The Resource Block contains all the data to uniquely identify and characterize the device. It corresponds to an electronic nameplate for the device. In addition to parameters required for operation of the device at the Fieldbus, the Resource Block provides information such as order code, device ID, hardware revision, software revision, device release etc.	
Transducer Block "Sensor 1" and "Sensor 2"	The field transmitter Transducer Blocks contain all the measuring and device-specific parameters relating to the measurement of the input variables.	
Display Transducer	The "Display" Transducer Block parameters enable configuration of the display.	
Advanced Diagnostic	All parameters for self-monitoring and diagnostics are grouped in this Transducer Block.	
Analog Input (AI)	In the AI function block, the process variables from the Transducer Blocks are processed for the subsequent automation functions in the control system (e.g. scaling, limit value processing).	
PID	This function block contains input channel processing, proportional-integral-differential control (PID) and analog output channel processing. Basic closed-control loops, control loops with feedforward control, cascade control and cascade control with limiting can all be performed.	
Input Selector (ISEL)	The block for signal selection (Input Selector Block - ISEL) allows you to select up to four inputs and generates an output based on the configured action.	

PROFIBUS® PA	
Profile version	3.02
Manufacturer-specific ID.:	1549 (Hex)
Device or bus address	126 (default) The device or bus address is set either using the configuration software, e.g. FieldCare or with the DIP switches on the electronics compartment  16.
GSD files	Sources of GSD files and device drivers: <ul style="list-style-type: none"> ■ GSD file: www.endress.com (Download Software) ■ Profile GSD file: www.profibus.com ■ FieldCare/DTM: www.endress.com (Automation Fieldbus Fieldbus device integration) ■ SIMATIC PDM: www.endress.com (Automation Fieldbus Fieldbus device integration) or www.fielddevices.com
Write lock	Write lock activated using hardware setting (DIP switch)
Cyclic data exchange	
Output data	Display value

PROFIBUS® PA	
Input data	Process temperature, internal reference temperature
Short description of blocks	
Physical Block	The Physical Block contains all the data to uniquely identify and characterize the device. It corresponds to an electronic nameplate for the device. In addition to parameters required for operation of the device at the Fieldbus, the Physical Block provides information such as order code, device ID, hardware revision, software revision etc. The display settings are also made using the Physical Block.
Transducer Block "Sensor 1" and "Sensor 2"	The field transmitter Transducer Blocks contain all the measuring and device-specific parameters relating to the measurement of the input variables.
Analog Input (AI)	In the AI function block, the process variables from the Transducer Blocks are processed for the subsequent automation functions in the control system (e.g. scaling, limit value processing).

Switch-on delay

HART®
4 s, during switch-on operation $I_a \leq 4.0$ mA

FOUNDATION Fieldbus™
8 s

PROFIBUS® PA
8 s

Power supply

Electrical connection

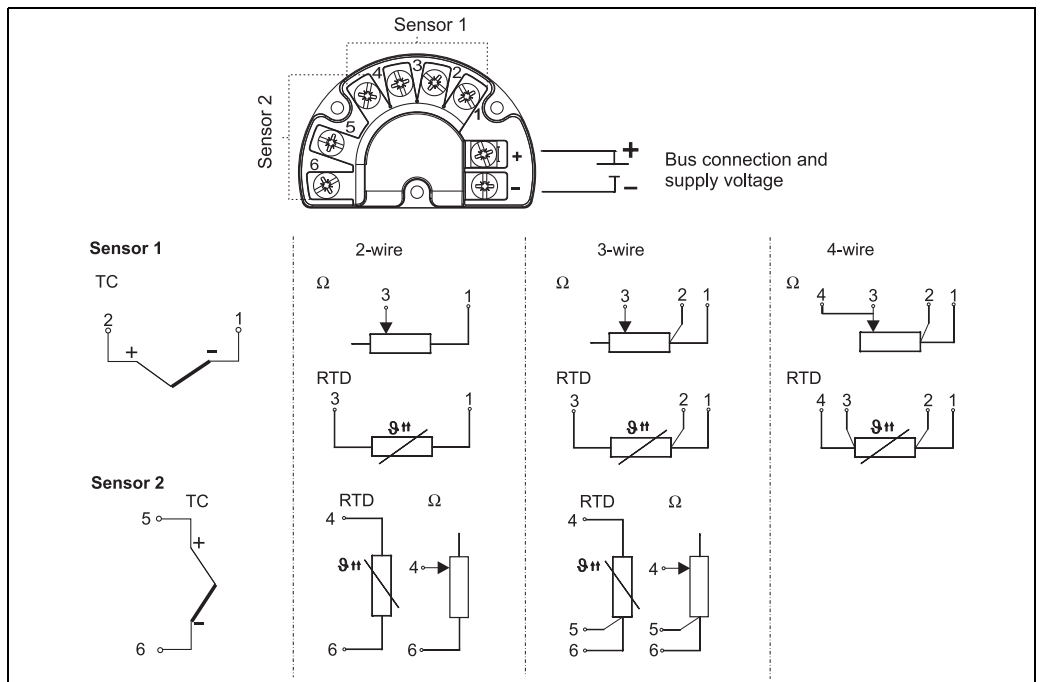

T09-TMT162ZZ-04-00-XX-en-000

Supply voltage

HART®
$U_b = 11$ to 40 V (8 to 40 V without display), reverse polarity protection



The TMT162 device must be powered by an 11 to 40 VDC power supply according to NEC Class 02 (low voltage/low current) with restricted power limited to 8 A/150 VA in the event of a short circuit (in accordance with IEC 61010-1, CSA 1010.1-92).

FOUNDATION Fieldbus™
$U_b = 9$ to 32 V, polarity-independent (reverse polarity protection for T17 housing), max. voltage $U_b = 35$ V According to IEC 60079-27, FISCO/FNICO

PROFIBUS® PA
$U_b = 9$ to 32 V, polarity-independent (reverse polarity protection for T17 housing), max. voltage $U_b = 35$ V According to IEC 60079-27, FISCO/FNICO

Cable entry

Version	Type
Thread	2x thread ½" NPT
	2x thread M20
	2x thread G½"
Cable entry	2x cable entry M20
Thread and fieldbus connector	2x thread ½" NPT 1x plug M12 PA
	2x thread M20x1.5 1x plug M12 PA
	2x thread M20x1.5 1x plug 7/8" PA
	2x thread ½" NPT 1x plug 7/8" FF
	2x thread M20x1.5 1x plug 7/8" FF

Residual ripple (HART®)

Perm. residual ripple $U_{ss} \leq 3$ V at $U_b = 13.5$ V, $f_{max.} = 1$ kHz

Performance characteristics

Response time Measured value update < 1 s per channel, depending on the type of sensor and connection method

Reference operating conditions Calibration temperature: + 25 °C ± 5 K (77 °F ± 9 °F)

Maximum measured error The accuracy data are typical values and correspond to a standard deviation of ± 3σ (normal distribution), i.e. 99.8% of all the measured values achieve the given values or better values.

	Designation	Accuracy	
		Digital	D/A ¹⁾
Resistance thermometer (RTD)	Cu100, Pt100, Ni100, Ni120	0.1 °C (0.18 °F)	0.02%
	Pt500	0.3 °C (0.54 °F)	0.02%
	Cu50, Pt50, Pt1000, Ni1000	0.2 °C (0.36 °F)	0.02%
	Cu10, Pt200	1 °C (1.8 °F)	0.02%
Thermocouples (TC)	K, J, T, E, L, U	typ. 0.25 °C (0.45 °F)	0.02%
	N, C, D	typ. 0.5 °C (0.9 °F)	0.02%
	S, B, R	typ. 1.0 °C (1.8 °F)	0.02%
	Measuring range	Accuracy	
		Digital	D/A ¹⁾
Resistance transmitter (Ω)	10 to 400 Ω	± 0.04 Ω	0.02%
	10 to 2000 Ω	± 0.8 Ω	0.02%
Voltage transmitter (mV)	-20 to 100 mV	± 10 μV	0.02%

1) % relates to the set span. Accuracy = digital + D/A accuracy, for 4 to 20 mA output

Physical input range of the sensors	
10 to 400 Ω	Cu10, Cu50, Cu100, Polynom RTD, Pt50, Pt100, Ni100, Ni120
10 to 2000 Ω	Pt200, Pt500, Pt1000, Ni1000
-20 to 100 mV	Thermocouple type: C, D, E, J, K, L, N, U
-5 to 30 mV	Thermocouple type: B, R, S, T

Sensor transmitter matching

Resistance thermometers have high linearity. However, every sensor has an individual temperature resistance characteristic curve. This characteristic curve must be described as accurately as possible in order to achieve a high level of accuracy in the linearization of the measured values in the transmitter. The TMT162 allows you to utilize two methods:

- Customer-specific linearization

Using PC configuration software or the HART® handheld, the device can be programmed with sensor-specific curve data. Once the sensor-specific data has been entered, the device utilizes this to generate a custom curve. Readwin® 2000 software supports by calculating sensor-specific curves.

- Callendar - Van Dusen coefficients

The Callendar - Van Dusen equation is described as:

$$R_T = R_0[1 + AT + BT^2 + C(T - 100)T^3]$$

where A, B and C are constants, commonly referred to as Callendar - Van Dusen coefficients. The precise values of A, B and C are derived from the calibration data and are specific to each RTD sensor.

The process involves programming the device with curve data for a specific RTD, instead of using the standard curve.

Sensor transmitter matching using any of the above methods substantially improves the temperature measurement accuracy of the entire system. This is as a result of the transmitter using the sensor's actual resistance vs. temperature curve data instead of the ideal curve data.

Repeatability 0.0015% of the physical input range (16 Bit). Resolution A/D conversion: 18 Bit

Influence of supply voltage (HART®) $\leq \pm 0.005\%/V$ deviation from 24 V, related to the full scale value

Long-term stability $\leq 0.1\text{ }^\circ\text{C}/\text{year}$ ($\leq 0.18\text{ }^\circ\text{F}/\text{year}$) or $\leq 0.05\%/ \text{year}$
Data under reference conditions. % relates to the set span. The larger value applies.

Influence of ambient temperature (temperature drift) Total temperature drift = input temperature drift + output temperature drift

Effect on the accuracy when ambient temperature changes by 1 K (1.8 °F):	
Input 10 to 400 Ω	typ. 0.001% of measured value, min. 1 m Ω
Input 10 to 2000 Ω	typ. 0.001% of measured value, min. 10 m Ω
Input -20 to 100 mV	typ. 0.001% of measured value, min. 0.2 μV
Input -5 to 30 mV	typ. 0.001% of measured value, min. 0.2 μV
Output 4 to 20 mA	typ. 0.001% of span

Typical sensitivity of resistance thermometers:		
Pt: $0.00385 * R_{\text{nominal}}/K$	Cu: $0.0043 * R_{\text{nominal}}/K$	Ni: $0.00617 * R_{\text{nominal}}/K$

Example Pt100: $0.00385 \times 100\ \Omega/K = 0.385\ \Omega/K$

Typical sensitivity of thermocouples:					
B: 10 $\mu\text{V}/K$ at 1000 $^\circ\text{C}$ (1832 $^\circ\text{F}$)	C: 20 $\mu\text{V}/K$ at 1000 $^\circ\text{C}$ (1832 $^\circ\text{F}$)	D: 20 $\mu\text{V}/K$ at 1000 $^\circ\text{C}$ (1832 $^\circ\text{F}$)	E: 75 $\mu\text{V}/K$ at 500 $^\circ\text{C}$ (932 $^\circ\text{F}$)	J: 55 $\mu\text{V}/K$ at 500 $^\circ\text{C}$ (932 $^\circ\text{F}$)	K: 40 $\mu\text{V}/K$ at 500 $^\circ\text{C}$ (932 $^\circ\text{F}$)
L: 55 $\mu\text{V}/K$ at 500 $^\circ\text{C}$ (932 $^\circ\text{F}$)	N: 35 $\mu\text{V}/K$ at 500 $^\circ\text{C}$ (932 $^\circ\text{F}$)	R: 12 $\mu\text{V}/K$ at 1000 $^\circ\text{C}$ (1832 $^\circ\text{F}$)	S: 12 $\mu\text{V}/K$ at 1000 $^\circ\text{C}$ (1832 $^\circ\text{F}$)	T: 50 $\mu\text{V}/K$ at 100 $^\circ\text{C}$ (212 $^\circ\text{F}$)	U: 60 $\mu\text{V}/K$ at 500 $^\circ\text{C}$ (932 $^\circ\text{F}$)

Example for calculating measured error for ambient temperature drift:

Input temperature drift = 10 K (18 $^\circ\text{F}$), Pt100, measuring range 0 to 100 $^\circ\text{C}$ (32 to 212 $^\circ\text{F}$)

Maximum process temperature: 100 $^\circ\text{C}$ (212 $^\circ\text{F}$)

Measured resistance value: 138.5 Ω (IEC 60751) at maximum process temperature

Typical temperature drift in Ω : (0.001% of 138.5 Ω) * 10 = 0.01385 Ω

Conversion to Kelvin: $0.01385\ \Omega / 0.385\ \Omega/K = 0.04\ \text{K}$ (0.054 $^\circ\text{F}$)

Influence of the reference junction (internal cold junction) Pt100 DIN IEC 60751 Cl. B (internal cold junction with thermocouples TC)

Installation conditions

Installation instructions

Mounting location

Direct mounting on the thermometer assembly or indirect mounting using mounting bracket (see 'Accessories').

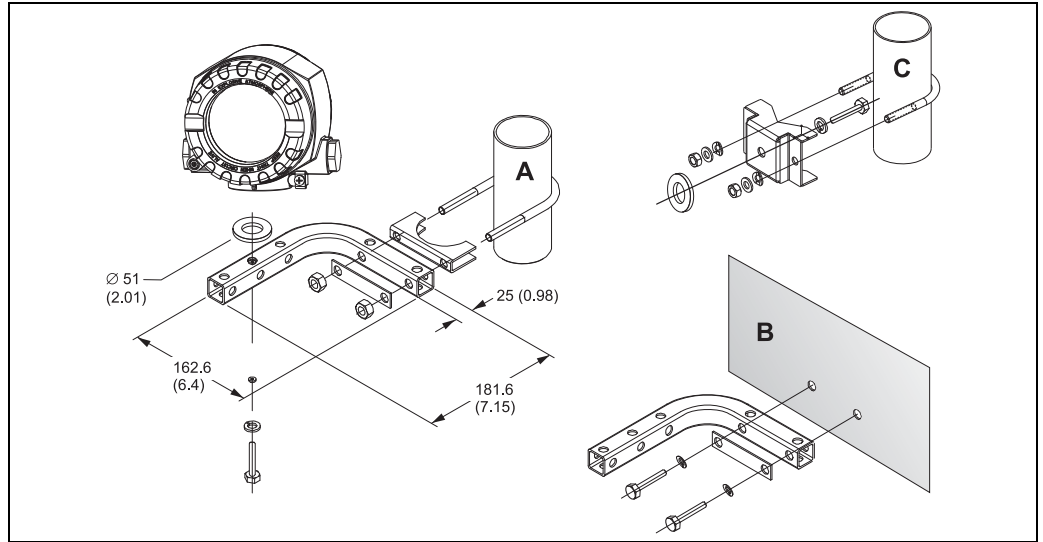

A, B: Mounting with combined wall/pipe mounting kit
C: Mounting with pipe mounting kit 2" /V4A

Environment conditions

Ambient temperature limits

- Without display: -40 to +85 °C (-40 to +185 °F)
- With display: -40 to +80 °C (-40 to +176 °F)

For use in Ex area, see Ex certificate



At temperatures < -20 °C (-4 °F), the display may react slowly. Readability of the display cannot be guaranteed at temperatures < -30 °C (-22 °F).

Storage temperature

- Without display: -40 to +100 °C (-40 to +212 °F)
- With display: -40 to +80 °C (-40 to +176 °F)

Altitude

Up to 2000 m (6560 ft) above sea level according to IEC 61010-1, CSA 1010.1-92

Climate class

As per IEC 60654-1, Class C

Degree of protection

- Aluminum die-cast or stainless steel housing: IP67, NEMA 4X
- Stainless steel housing for hygienic applications (T17 housing): IP66/IP68 (1.83 m H₂O for 24 h), NEMA 4X, NEMA 6P

Shock and vibration resistance

3g / 2 to 150 Hz as per IEC 60 068-2-6



Care should be taken when using L-form brackets (see wall/tube 2" brackets in Section 'Accessories') since this can cause resonance. Caution: vibrations at the transmitter must not exceed the specified values.

Electromagnetic compatibility (EMC)**CE Electromagnetic Compatibility Compliance**

EMC meets all relevant requirements listed under EN 61326 Series and NAMUR NE21. Details as per declaration of conformity.

This recommendation is a uniform and practical way of determining whether the devices used in laboratories and process control are immune to interference with an objective to increase its functional safety.

ESD (Electrostatic discharge)	IEC 61000-4-2	6 kV cont., 8 kV air	
Electromagnetic fields	IEC 61000-4-3	0.08 to 2 GHz (0.08 to 4 GHz for FF/PA) 0.08 to 2 GHz for HART 2 to 2.7 GHz	10 V/m 10 V/m 30 V/m 1V/m
Burst (fast transient)	IEC 61000-4-4	1 kV (2 kV for HART)	
Surge	IEC 61000-4-5	1 kV asym. (0.5 kV sym. for HART)	
Conducted RF	IEC 61000-4-6	0.01 to 80 MHz	10 V

Condensation

Permitted

Measuring category

Measuring category II as per IEC 61010-1. The measuring category is provided for measurements at circuits with a direct electrical connection to the low voltage supply.

Pollution degree

Pollution degree 2 as per IEC 61010-1

Mechanical construction**Design, dimensions**

Dimensions in mm (in)

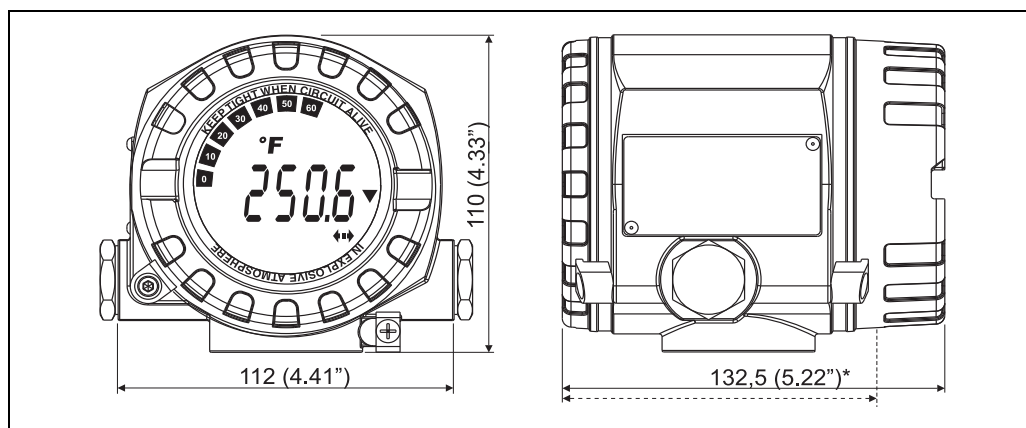

Die-cast aluminum housing for general purpose or, as option, stainless steel housing (316L)

* Dimensions without display = 112 mm (4.41")

T09-TMT162Z-06-00-xx-xx-001

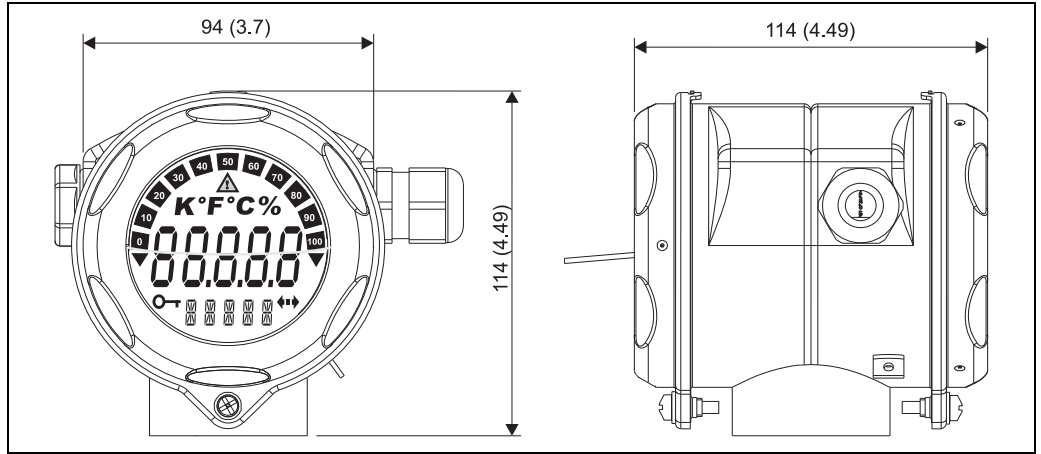

Optional T17 stainless steel housing for hygienic applications

T09-TMT162Z2-06-00-xx-en-003

- Separate electronics compartment and connection compartment
- Display pluggable in 90° stages

Weight

- Approx. 1.4 kg (3 lbs), with display, aluminum housing
- Approx. 4.2 kg (9.3 lbs), with display, stainless steel housing
- Approx. 1.25 kg (2.76 lbs), with display, T17 housing

Material

Housing	Nameplate
Die-cast aluminum housing AlSi10Mg/AlSi12 with powder coating on polyester basis	Aluminum AlMgI, anodized in black
Stainless steel 1.4435 (AISI 316L)	1.4404 (AISI 316L)
Stainless steel 1.4435 (AISI 316L) for hygienic applications (T17 housing)	-

Terminals

2.5 mm² (12 AWG) plus wire end ferrules

Human interface

Display elements

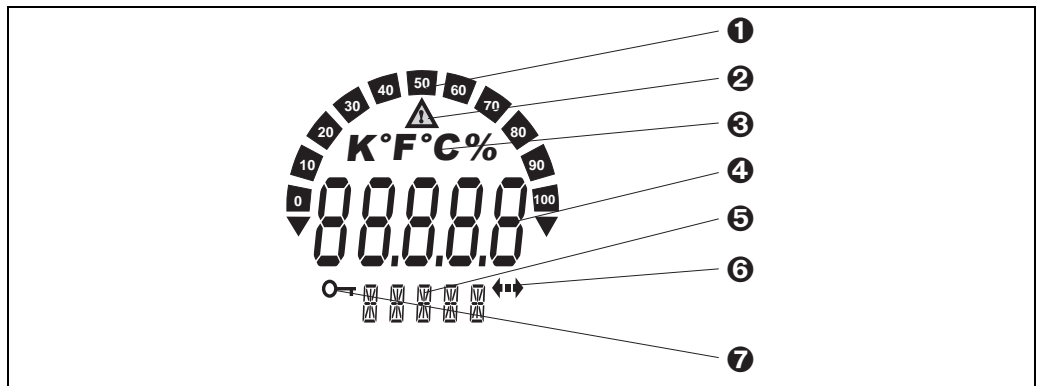

T09-TMT162Z2-07-00-00-xx-001

LC display of the field transmitter (illuminated, pluggable in 90°-stages)

- 1: Bar graph display in 10 % stages with indicators for overranging/underranging
- 2: 'Caution' display
- 3: Unit display K, °F, °C or %
- 4: Measured value display - height of digits 20.5 mm (0.81")
- 5: Status and information display
- 6: 'Communication' display
- 7: 'Programming disabled' display

Operating elements

No operating elements are present directly on the display to prevent manipulation.

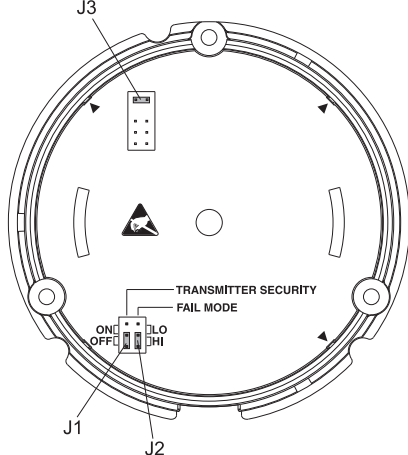
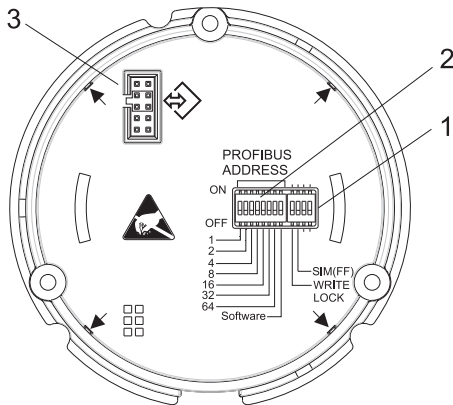
HART®	FOUNDATION Fieldbus™ PROFIBUS® PA
<p>Jumpers J1, J2 and J3 for the hardware setup can be found in the electronics compartment.</p>  <p style="text-align: right;">T09-TMT162ZZ-19-00-00-xx-001</p> <p><i>Hardware setup</i></p> <p>J1 Write lock J2 Failure Mode (only if microcontroller fails) J3 For reduced power supply voltage (11 V to 8 V) without display</p>	 <p style="text-align: right;">T09-TMT162ZZ-19-00-00-xx-002</p> <p><i>Hardware setup</i></p> <p>1: DIP switch for write lock; simulation (precondition for FOUNDATION Fieldbus™ simulation mode) 2: DIP switch for PROFIBUS® device address 3: Electrical connection display and service interface (CDI)</p>

Remote operation

Remote operation via:

- HART® protocol
- FOUNDATION Fieldbus™
- PROFIBUS® PA

Certificates and approvals

CE-Mark

The device meets the legal requirements of the EC directives. Endress+Hauser confirms that the device has been successfully tested by applying the CE mark.

MTBF

- HART®: **147 a**
- FOUNDATION Fieldbus™ / PROFIBUS® PA: **126 a**

according to Siemens Standard SN29500

ATEX

ATEX II1G Ex ia IIC T6/T5/T4	HART®	FOUNDATION Fieldbus™ / PROFIBUS® PA
Power supply (+ and - terminals)	$U_i \leq 30 \text{ V DC}$ $I_i \leq 300 \text{ mA}$ $P_i \leq 1000 \text{ mW}$ $C_i \leq 5 \text{ nF}$ $L_i \approx 0$	$U_i \leq 17.5 \text{ V DC}$ or: $U_i \leq 24 \text{ V DC}$ $I_i \leq 500 \text{ mA}$ $I_i \leq 250 \text{ mA}$ $P_i \leq 5.5 \text{ W}$ $P_i \leq 1.2 \text{ W}$ $C_i \leq 5 \text{ nF}$ $L_i = 10 \text{ }\mu\text{H}$ Suitable for connecting to a fieldbus system in accordance with the FISCO/FNICO model (valid for FOUNDATION Fieldbus™ protocol)
ATEX II3G Ex nA II T6/T5/T4	HART®	FOUNDATION Fieldbus™ / PROFIBUS® PA
Power supply (+ and - terminals)	$U \leq 40 \text{ V DC}$	$U \leq 32 \text{ V DC}$
Output	$I = 4 \text{ to } 20 \text{ mA}$	Current consumption $I \leq 11 \text{ mA}$

ATEX II3G Ex nL IIC T6/T5/T4		HART®	FOUNDATION Fieldbus™ / PROFIBUS® PA
Power supply (+ and - terminals)		-	U _i ≤ 32 V DC C _i ≤ 5 nF L _i = 10 μH
Temperature range	T6	Ta = -40 °C to +55 °C	
	T5	Ta = -40 °C to +70 °C	
with display	T4	Ta = -40 °C to +70 °C	
without display	T4	Ta = -40 °C to +85 °C	

ATEX II2D Ex tD A21 IP67 T110°C ATEX II2G Ex d IIC T6/T5/T4 Note! Not valid for T17 housing		HART®	FOUNDATION Fieldbus™ / PROFIBUS® PA
Power supply (+ and - terminals)		U ≤ 40 V DC P ≤ 3 W	U ≤ 35 V DC P ≤ 3 W
Temperature range for Ex d	T6	Ta = -40 °C to +55 °C	
	T5	Ta = -40 °C to +70 °C	
	T4	Ta = -40 °C to +80 °C	
Temperature range for dust		Ta = -40 °C to +80 °C	

FM (Factory Mutual)**Intrinsic Safety; Non-Incendive**

Mark:

- IS / I / 1 / ABCD / T4 Ta = 85 °C, Entity;
- NI / I / 2 / ABCD / T4 Ta = 85 °C;
- NI / I / 2 / ABCD / T4 Ta = 85 °C, NIFW;
- I / 0 / AEx ia IIC T4 Ta = 85 °C, Entity;

For Entity Parameters/Non-incendive Field Wiring parameters, refer to CSA approval under: Intrinsic Safety.

Explosion-proof¹⁾, Dust ignition-proof

Mark:

- XP / I / 1 / ABCD / T6 Ta = 55 °C; T5 Ta = 70 °C; T4 Ta = 85 °C
- DIP / II, III / 1 / EFG / T6 Ta = 55 °C; T5 Ta = 70 °C; T4 Ta = 85 °C
- XP / I / 1 / IIC T6

For connection data, see CSA approval under: Explosion-proof, Dust ignition-proof.
Ta = 55 °C; T5 Ta = 70 °C; T4 Ta = 85 °C; Type 4X; IP66, IP67**CSA (Canadian Standard Association)****Explosion-proof¹⁾, Dust ignition-proof**

Mark:

Class I, Zone 1, Ex d IIC: Class I, Div. 1, Groups A, B, C & D; Class II, Div. 1 Groups E, F & G; Class III

Connection data:

	HART®	FOUNDATION Fieldbus™ / PROFIBUS® PA
Power supply (+ and - terminals)	U ≤ 40 V DC P ≤ 3 W	U ≤ 35 V DC P ≤ 3 W
Output	I = 4 to 20 mA	Current consumption I ≤ 11 mA
For temperature range, see ATEX II1G, II3G table Housing type 4X.		

Intrinsic Safety

Mark:

Ex ia IIC: Class I, Div. 1, Groups A, B, C & D; Class II, Div. 1, Groups E, F & G; Class III, Div. 1

1) not available for T17 housing

Connection data:

	HART®	FOUNDATION Fieldbus™ / PROFIBUS® PA	
Power supply (+ and - terminals)	Ui/Vmax = 30V DC Imax = 300 mA Pmax = 1 W Ci = 5.3 nF Li = 0 µH	Entity: Ui/Vmax = 24 V DC Imax = 250 mA Pmax = 1.2 W Ci = 5 nF Li = 10 µH	FISCO: Ui/Vmax = 17.5 V DC Imax = 500 mA Pmax = 5.5 W Ci = 5 nF Li = 10 µH
For temperature range, see ATEX II1G, II3G table.			

Non-Incendive

Mark:

Ex nA IIC: Class I, Div. 2, Groups A, B, C & D; Class II, Div. 2, Groups E, F, G; Class III, Div. 2

Connection data:

	HART®	FOUNDATION Fieldbus™ / PROFIBUS® PA
Power supply (+ and - terminals)	Ui/Vmax = 30 V DC Ci = 5.3 nF Li = 0 µH	Ui/Vmax ≤ 35 V DC Ci = 5 nF Li = 10 µH
Output	I = 4 to 20 mA	Current consumption I ≤ 11 mA
For temperature range, see ATEX II1G, II3G table. Housing type 4X.		

For further details on the available Ex versions (ATEX, CSA, FM, etc.), please contact your nearest Endress+Hauser sales organization. All relevant data for hazardous areas can be found in separate Ex documentation. If required, please request copies.

GL Ship building approval - Germanischer Lloyd (HART® device only)

Other standards and guidelines

- IEC 60529: Degree of protection by housing (IP-Code)
- IEC 61010-1: Safety requirements for electrical measurement, control and laboratory instrumentation.
- EN 61326-series: Electrical equipment for measurement, control and laboratory use - EMC requirements.
- NAMUR: User association of automation technology in process industries (www.namur.de)
- NEMA: Standardization association for the electrical industry in North America.

UL Recognized component to UL 3111-1 (HART® device only)

CSA GP CSA General Purpose

Functional safety according to IEC 61508/ IEC 61511 FMEDA including SFF determination and PFD_{AVG} -calculation according to IEC 61508. See also Functional Safety Manual in Section 'Documentation' (for HART® device).

Certification FOUNDATION Fieldbus™ The temperature transmitter is certified and registered by the Fieldbus Foundation. The device meets all the requirements of the following specifications:

- Certified according to FOUNDATION Fieldbus™ specification
- FOUNDATION Fieldbus™ H1
- Interoperability Test Kit (ITK), revision status 5.2.0 (device certification no. 7): the device can also be operated with certified devices of other manufacturers
- Physical Layer Conformance Test of Fieldbus FOUNDATION™ (FF-830 FS 1.0)

Certification PROFIBUS® PA The temperature transmitter is certified and registered by the PNO (PROFIBUS® Nutzerorganisation e. V.), PROFIBUS user organization. The device meets all the requirements of the following specifications:

- Certified in accordance with PROFIBUS® PA Profile 3.02
- The device can also be operated with certified devices of other manufacturers (interoperability)

Ordering information

Detailed ordering information is available from the following sources:

- In the **Product Configurator** on the Endress+Hauser website:
www.endress.com → Select country → Instruments → Select device → Product page function:
Configure this product
- From your Endress+Hauser Sales Center:
www.endress.com/worldwide

Product Configurator - the tool for individual product configuration:

- Up-to-the-minute configuration data
- Depending on the device: Direct input of measuring point-specific information such as measuring range or operating language
- Automatic verification of exclusion criteria
- Automatic creation of the order code and its breakdown in PDF or Excel output format
- Ability to order directly in the Endress+Hauser Online Shop

Accessories

Accessories included in the scope of delivery:

- Hard copy of multilingual Brief Operating Instructions
- Operating Instructions on CD-ROM
- Additional ATEX documentation:
ATEX Safety Instructions (XA), Control Drawings (CD)
- 1 set of lead-sealable screws in stainless steel housing for hygiene applications (T17 housing)

Device-specific accessories

Type	Description	Order code	
Blanks (blind)	<ul style="list-style-type: none"> ■ M20x1,5 EEx-d/XP ■ G 1/2" EEx-d/XP ■ NPT 1/2" Aluminum ■ NPT 1/2" V4A 	51004489 51004916 51004490 51006888	
Cable glands	■ M20x1.5 cable entry for 1 sensor	51004949	
	<ul style="list-style-type: none"> ■ NPT 1/2" cable gland 2 x D0.5 cables for 2 sensors ■ M20x1.5 cable gland 2 x D0.5 cables for 2 sensors 	51004654 51004653	
Adapter	M20x1.5/NPT 1/2" cable entry	51004387	
Wall and stand pipe mounting brackets	<ul style="list-style-type: none"> ■ Stainless steel wall/tube 2" ■ Stainless steel tube 2" V4A 	51004823 51006412	
Fieldbus connector (FF)	Threaded connection	Cable connecting thread	
	<ul style="list-style-type: none"> ■ NPT 1/2" ■ M20 	<ul style="list-style-type: none"> ■ 7/8" ■ 7/8" 	71005803 71005804
Fieldbus connector (PA)	<ul style="list-style-type: none"> ■ M20x1.5 ■ NPT 1/2" ■ M20x1.5 	<ul style="list-style-type: none"> ■ M12 ■ M12 ■ 7/8" 	71090687 71005802 71089147
	Surge arrester HAW569	M20x1.5 threaded connection; suitable for HART®, FF and PA fieldbus connection Order code: HAW569-A11A for Non-hazardous area Order code: HAW569-B11A for hazardous area ATEX 2(1)G EEx ia IIC (More technical data see Technical Information: TI1013K/09)	

System components and Recorders

Accessory	Description
Graphic Data Manager Memograph M	The Memograph M graphic data manager provides information on all the relevant process variables. Measured values are recorded correctly, limit values are monitored and measuring points analyzed. The data are stored in the 256 MB internal memory and also on a SD card or USB stick. For details, see "Technical Information" TI133R/09

Accessory	Description
Multi channel recorder Ecograph T	Multi-channel data recording system with LC color graphic display (120 mm / 4.7" screen size), galvanically isolated universal inputs (U, I, TC, RTD), digital input, transmitter power supply, limit relay, communication interfaces (USB, Ethernet, RS232/485), internal Flash memory and CompactFlash card. For details, see "Technical Information" TI115R/09
RN221N	Active barrier with power supply for safe separation of 4-20 mA standard signal circuits. Offers bidirectional HART transmission. For details, see "Technical Information" TI073R/09
RNS221	Supply unit for powering two 2-wire measuring devices solely in the non-Ex area. Bidirectional communication is possible via the HART communication jacks. For details, see "Technical Information" TI081R/09
RB223	One or two-channel, loop-powered barrier for the safe separation of 4 to 20 mA standard signal circuits. Bidirectional communication is possible via the HART communication jacks. For details, see "Technical Information" TI132R/09
RIA14, RIA16	Loop powered field indicator for 4 to 20 mA current loops, RIA14 with explosion proof enclosure. For details, see "Technical Informations" TI143R/09 and TI144R/09
RIA15	Process display, digital loop powered display for 4 to 20 mA current loops. For details, see "Technical Information" TI1040K/09

Documentation

- 'iTEMP® TMT162 HART' Operating manual (BA132R/09/) +
Functional safety manual (SD005R/09/en)
'iTEMP® TMT162 HART' Brief operating instructions (KA250R/09)
- 'iTEMP® TMT162 FOUNDATION Fieldbus™' Operating manual (BA224R/09/en)
'iTEMP® TMT162 FOUNDATION Fieldbus™' Brief operating instructions (KA189R/09)
- 'iTEMP® TMT162 PROFIBUS® PA' Operating manual (BA275R/09/en)
'iTEMP® TMT162 PROFIBUS® PA' Brief operating instructions (KA276R/09)
- Ex supplementary documentation (HART®):
ATEX II2(1)G: XA020R/09/a3
ATEX II2G, EEx d: XA031R/09/a3
ATEX II2D: XA032R/09/a3
ATEX II1G: XA033R/09/a3
ATEX II1/2GD: XA065R/09/a3
- Ex supplementary documentation (FOUNDATION Fieldbus™ / PROFIBUS® PA):
ATEX II2G, EEx d: XA058R/09/a3
ATEX II1/2D: XA059R/09/a3
ATEX II1G: XA060R/09/a3
ATEX EEx ia + EEx d: XA061R/09/a3
ATEX II1/2GD: XA067R/09/a3
- Technical Informations Omnigrad S TMT162R and TMT162C
(TI266T/02/en and TI267T/02/en)

Instruments International

Endress+Hauser
Instruments International AG
Kaegenstrasse 2
4153 Reinach
Switzerland

Tel.+41 61 715 81 00
Fax+41 61 715 25 00
www.endress.com
info@ii.endress.com

Endress + Hauser 
People for Process Automation