

Technical Information

iTEMP[®] TMT85

Dual Input Temperature Transmitter
with FOUNDATION Fieldbus™ communication



Application

- Temperature transmitter with 2 universal input channels and FOUNDATION Fieldbus™ protocol for the conversion of different input signals into digital output signals
- The iTEMP[®] TMT85 stands out due to signal reliability, long-term stability, high precision and advanced diagnostics (important in critical processes)
- For the highest level of safety, availability and risk reduction
- Universal input usable for resistance thermometer (RTD), thermocouple (TC), resistance transmitter (Ω), voltage transmitter (mV)
- DIN B style transmitter to fit in the smallest terminal heads or in remote housings in accordance with DIN EN 50446
- Optional installation in field housings even for use in Ex d areas
- Mounting bracket pipe or wall for the field housing

Your benefits

- Easy and standardized communication via FOUNDATION Fieldbus™ H1
- Straightforward design of measuring points in Ex-areas through FISCO/FNICO conformity in accordance with IEC 600079-27
- Safe operation in hazardous areas thanks to international approvals such as FM IS, NI; CSA IS, NI; ATEX Ex ia, Ex nA for intrinsically safe installation in zone 1 and zone 2
- High accuracy through sensor-transmitter matching
- Reliable operation with sensor monitoring and device hardware fault recognition
- Several mounting versions and sensor connection combinations
- Rapid no-tools wiring due to optional spring terminal technology

Function and system design

Measuring principle

Electronic recording and conversion of various input signals in industrial temperature measurement.

Measuring system

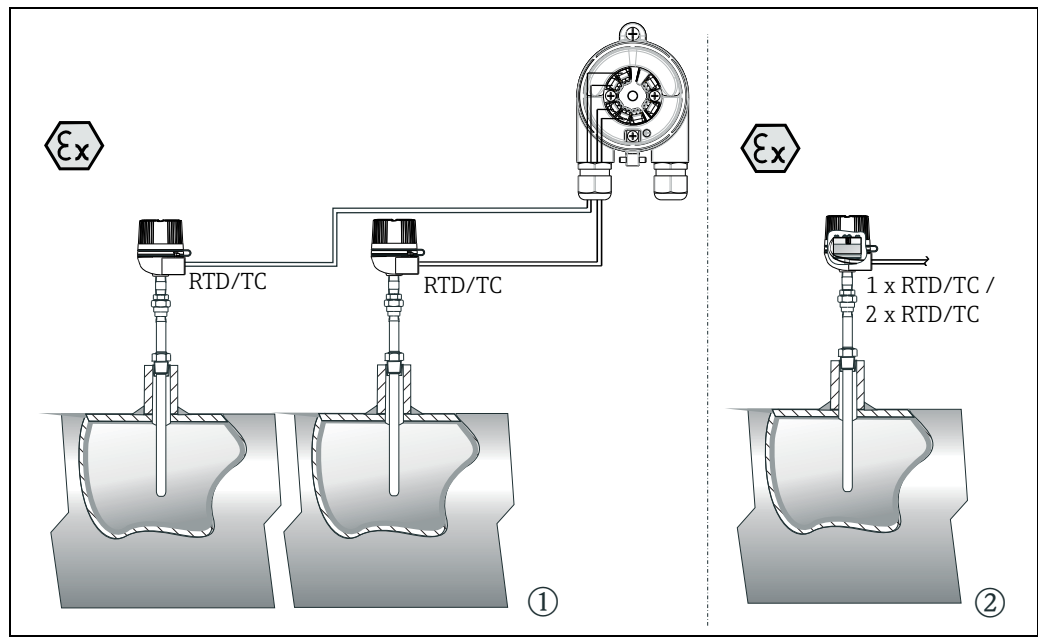

A0007667

Application examples

- ① Two sensors with measuring input (RTD or TC) in remote installation with the following advantages: drift warning, sensor backup function and temperature-dependent switching
- ② Built-in head transmitter - 1 x RTD/TC or 2 x RTD/TC as redundancy

Endress+Hauser is a producer of a wide range of resistance thermometers, thermocouples and matching thermowells.

In conjunction with these components, the temperature head transmitter forms a complete measuring point for various applications in the industrial sector.

Device architecture

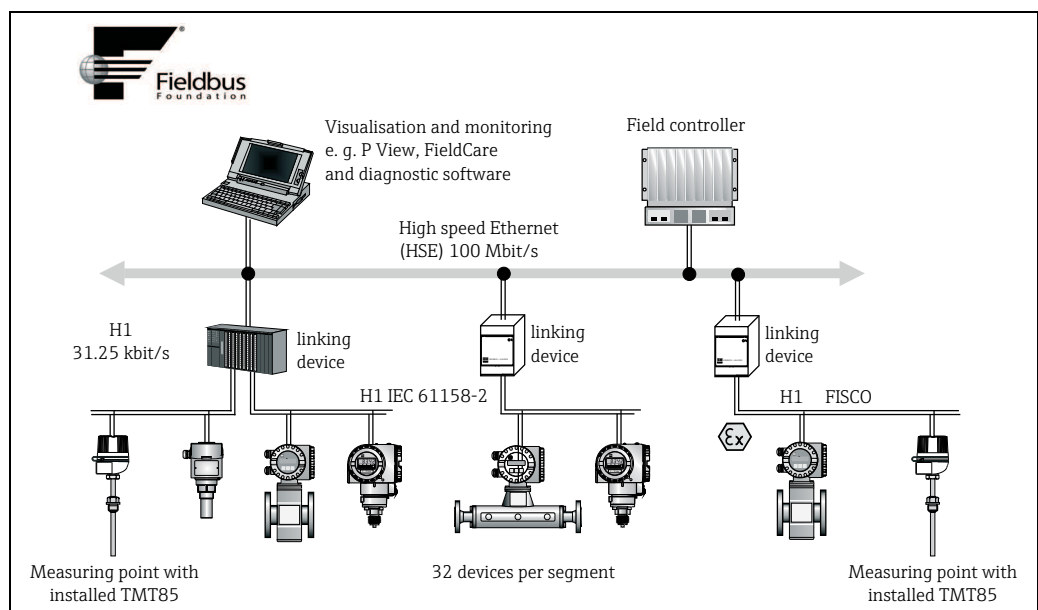

A0007668-EN

System integration via FOUNDATION Fieldbus™

The temperature head transmitter is a two-wire device with two measuring inputs. Using FOUNDATION Fieldbus™, the device transfers converted signals from resistance thermometers and thermocouples in addition to other resistance and millivolt signals. The device is powered via the FOUNDATION Fieldbus™ H1 bus and can be installed as an intrinsically safe apparatus in zone 1 hazardous areas. The device is used for instrumentation purposes in the terminal head form B as per DIN EN 50446. Data transfer takes place via the following function blocks:

- 2 x 3 analog input (AI),
- 1 x standard PID controller (PID) and
- 1 x input selector (ISEL).

Sensor diagnosis functions

Sensor diagnoses such as cable open circuit, short-circuit, cable corrosion, wiring error and device hardware error are supported. In addition, the work area of the sensor and the ambient temperature are monitored.

2-channel functions

These functions increase the reliability and availability of the process values:

- Sensor backup switches to the second sensor if the primary sensor fails.
- Drift warning or alarm if the deviation between sensor 1 and sensor 2 is less than or greater than a predefined limit value.
- Temperature-dependent switching between sensors which have advantages in different ranges.

Input

Measured variable	Temperature (temperature linear transmission behavior), resistance and voltage.
Measuring range	The transmitter records different measuring ranges depending on the sensor connection and input signals (see "Type of input").
Type of input	It is possible to connect two sensors which are independent of each other. The measuring inputs are not galvanically isolated from each other.

Type of input	Designation	Measuring range limits	Min. span
Resistance thermometer (RTD) as per IEC 60751 ($\alpha = 0.00385$) as per JIS C1604-81 ($\alpha = 0.003916$) as per DIN 43760 ($\alpha = 0.006180$) as per Edison Copper Winding No.15 ($\alpha = 0.004274$) as per Edison Curve ($\alpha = 0.006720$) as per GOST ($\alpha = 0.003911$) as per GOST ($\alpha = 0.004280$)	Pt100	-200 to +850 °C (-328 to +1562 °F)	10 K
	Pt200	-200 to +850 °C (-328 to +1562 °F)	
	Pt500	-200 to +250 °C (-328 to +482 °F)	
	Pt1000	-200 to +250 °C (-238 to +482 °F)	
	Pt100	-200 to +649 °C (-328 to +1200 °F)	10 K
	Ni100	-60 to +250 °C (-76 to +482 °F)	10 K
	Ni1000	-60 to +150 °C (-76 to +302 °F)	
	Cu10	-100 to +260 °C (-148 to +500 °F)	10 K
	Ni120	-70 to +270 °C (-94 to +518 °F)	10 K
	Pt50	-200 to +1100 °C (-328 to +2012 °F)	10 K
Pt100	-200 to +850 °C (-328 to +1562 °F)	10 K	
Cu50, Cu100	-200 to +200 °C (-328 to +392 °F)	10 K	
Pt100 (Callendar-Van Dusen)	10 to 400 Ω	10 Ω	
Polynomial nickel	10 to 2000 Ω	100 Ω	
Polynomial copper	10 to 400 Ω	10 Ω	
	10 to 2000 Ω	100 Ω	
	10 to 400 Ω	10 Ω	
	10 to 2000 Ω	100 Ω	

Type of input	Designation	Measuring range limits		Min. span
		<ul style="list-style-type: none"> Connection type: 2-wire, 3-wire or 4-wire connection, sensor current: ≤ 0.3 mA For 2-wire circuit, compensation for wire resistance possible (0 to 30 Ω) For 3-wire and 4-wire connection, sensor wire resistance up to max. 50 Ω per wire 		
Resistance transmitter	Resistance Ω	10 to 400 Ω 10 to 2000 Ω		10 Ω 100 Ω
Thermocouples (TC) as per IEC 584, Part 1 as per ASTM E988 as per DIN 43710	Type A (W5Re-W20Re)	0 to +2500 °C (+32 to +4532 °F)	Recommended temperature range: 0 to +2000 °C (+32 to +3632 °F)	50 K
	Type B (PtRh30-PtRh6)	+40 to +1820 °C (+104 to +3308 °F)	+100 to +1500 °C (+212 to +2732 °F)	50 K
	Type E (NiCr-CuNi)	-270 to +1000 °C (-454 to +1832 °F)	0 to +750 °C (+32 to +1382 °F)	50 K
	Type J (Fe-CuNi)	-210 to +1200 °C (-346 to +2192 °F)	+20 to +700 °C (+68 to +1292 °F)	50 K
Type K (NiCr-Ni)	-270 to +1372 °C (-454 to +2501 °F)	0 to +1100 °C (+32 to +2012 °F)	50 K	
Type N (NiCrSi-NiSi)	-270 to +1300 °C (-454 to +2372 °F)	0 to +1100 °C (+32 to +2012 °F)	50 K	
Type R (PtRh13-Pt)	-50 to +1768 °C (-58 to +3214 °F)	0 to +1400 °C (+32 to +2552 °F)	50 K	
Type S (PtRh10-Pt)	-50 to +1768 °C (-58 to +3214 °F)	0 to +1400 °C (+32 to +2552 °F)	50 K	
Type T (Cu-CuNi)	-260 to +400 °C (-436 to +752 °F)	-185 to +350 °C (-301 to +662 °F)	50 K	
Type C (W5Re-W26Re)	0 to +2315 °C (+32 to +4199 °F)	0 to +2000 °C (+32 to +3632 °F)	50 K	
Type D (W3Re-W25Re)	0 to +2315 °C (+32 to +4199 °F)	0 to +2000 °C (+32 to +3632 °F)	50 K	
Type L (Fe-CuNi)	-200 to +900 °C (-328 to +1652 °F)	0 to +750 °C (+32 to +1382 °F)	50 K	
Type U (Cu-CuNi)	-200 to +600 °C (-328 to +1112 °F)	-185 to +400 °C (-301 to +752 °F)	50 K	
	<ul style="list-style-type: none"> 2-wire connection Internal cold junction (Pt100, Class B) External cold junction: value adjustable from -40 to +85 °C (-40 to +185 °F) Maximum sensor resistance 10 kΩ (if the sensor resistance is greater than 10 kΩ, an error message is output in accordance with NAMUR NE89) 			
Voltage transmitter (mV)	Millivolt transmitter (mV)	-20 to 100 mV		5 mV

When assigning both sensor inputs, the following connection combinations are possible:

		Sensor input 1			
		RTD or resistance transmitter, 2-wire	RTD or resistance transmitter, 3-wire	RTD or resistance transmitter, 4-wire	Thermocouple (TC), voltage transmitter
Sensor input 2	RTD or resistance transmitter, 2-wire	✓	✓	-	✓
	RTD or resistance transmitter, 3-wire	✓	✓	-	✓
	RTD or resistance transmitter, 4-wire	-	-	-	-
	Thermocouple (TC), voltage transmitter	✓	✓	✓	✓

Output

Output signal	<ul style="list-style-type: none"> ■ FOUNDATION Fieldbus™ H1, IEC 61158-2 ■ FDE (Fault Disconnection Electronic) = 0 mA ■ Data transmission rate: supported baud rate = 31.25 kBit/s ■ Signal coding = Manchester II ■ Output data: Available values via AI blocks: temperature (PV), temp sensor 1 + 2, terminal temperature ■ LAS (link active scheduler), LM (link master) function is supported: Thus, the head transmitter can assume the function of a link active scheduler (LAS) if the current link master (LM) is no longer available. The device is supplied as a BASIC device. To use the device as an LAS, this must be defined in the distributed control system and activated by downloading the configuration to the device. ■ In accordance with IEC 60079-27, FISCO/FNICO
Breakdown information	Status message in accordance with FOUNDATION Fieldbus™ specification.
Linearization/transmission behavior	Temperature linear, resistance linear, voltage linear
Mains voltage filter	50/60 Hz
Galvanic isolation	U = 2 kV AC (sensor input to the output)
Current consumption	≤ 11 mA
Switch-on delay	8 s

Data of the FOUNDATION Fieldbus interface

Basic Data

Device Type	11CE (hex)
Device Revision	02
Node address	Default: 247
ITK Version	6.0.1
ITK-Certification Driver-No.	IT085900
Link Master (LAS) capable	yes
Link Master / Basic Device selectable	yes; Default: Basic Device
Number VCRs	44
Number of Link-Objects in VFD	50

Virtual communication references (VCRs)

Permanent entries	1
Fully configurable entries	43

Link Settings

Slot time	8
Min. Inter PDU delay	10
Max. response delay * slot time	24

Blocks

Block description	Block index ¹⁾	Execution time (macro cycle ≤ 500 ms)	Block class
Resource Block	400	-	Extended
Transducer Block Sensor 1	500	-	Manufacturer-specific
Transducer Block Sensor 2	600	-	Manufacturer-specific
Transducer Block Display	700	-	Manufacturer-specific
Transducer Block Adv. Diag.	800	-	Manufacturer-specific
Function block AI1	900	30 ms	Extended
Function block AI2	1000	30 ms	Extended
Function block AI3	1100	30 ms	Extended
Function block AI4	(1200)	30 ms (not instantiated)	Extended
Function block AI5	(1300)	30 ms (not instantiated)	Extended
Function block AI6	(1400)	30 ms (not instantiated)	Extended
Function block PID	1200 (1500)	25 ms	Standard
Function block ISEL	1300 (1600)	20 ms	Standard

1) The values in brackets are valid if all the AI blocks (AI1-AI6) are instantiated.

Brief description of the blocks

Resource Block

The Resource Block contains all the data that clearly identify and characterize the device. It is like an electronic device nameplate. In addition to parameters that are needed to operate the device on the fieldbus, the Resource Block also makes other information available such as the order code, device ID, hardware version, firmware version, etc.

Transducer Block "Sensor 1" and "Sensor 2"

The Transducer Blocks of the head transmitter contain all the measurement-related and device-specific parameters that are relevant for measuring the input variables.

Display Transducer

The parameters of the "Display" Transducer Block allow the configuration of the optional display.

Advanced Diagnostic

All the parameters for automatic monitoring and diagnosis are grouped together in this Transducer Block.

Analog Input (AI)

In the AI function block, the process variables from the Transducer Blocks are prepared for subsequent automation functions in the control system (e.g. scaling, limit value processing).

PID

This function block contains input channel processing, proportional integral-differential control (PID) and analog output channel processing. The following can be implemented: basic controls, feedforward control, cascade control and cascade control with limiting.

Input Selector (ISEL)

The block for selecting a signal (Input Selector Block - ISEL) allows the user to choose up to four inputs and generates an output based on the configured action.

Power supply

Electrical connection

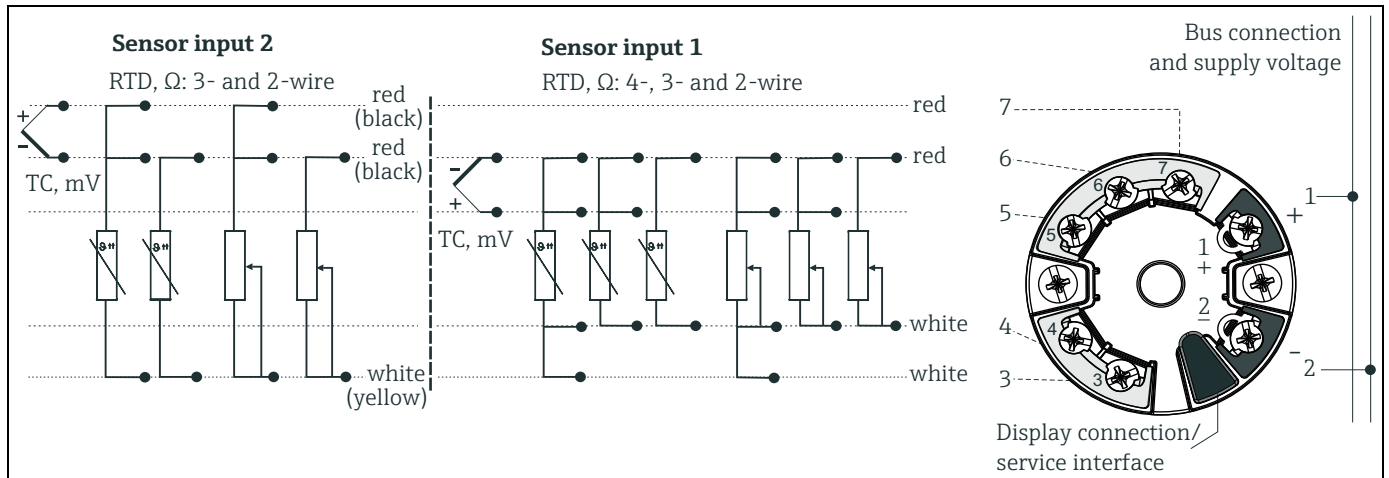

Terminal assignment of head transmitter.

Supply voltage

$U = 9$ to 32 V DC, polarity independent (max. voltage $U_b = 35$ V)

Performance characteristics

Response time

1 s per channel

Reference operating conditions

- Calibration temperature: $+25\text{ °C} \pm 5\text{ K}$ ($77\text{ °F} \pm 9\text{ °F}$)
- Supply voltage: 24 V DC
- 4-wire circuit for resistance adjustment

Resolution

Resolution A/D converter = 18 bit

Maximum measured error



The accuracy data are typical values and correspond to a standard deviation of $\pm 3\sigma$ (normal distribution), i.e. 99.8% of all the measured values achieve the given values or better values.

	Designation	Performance characteristics
Resistance thermometers (RTD)	Cu100, Pt100, Ni100, Ni120 Pt500	0.1 °C (0.18 °F) 0.3 °C (0.54 °F)
	Cu50, Pt50, Pt1000, Ni1000 Cu10, Pt200	0.2 °C (0.36 °F) 1 °C (1.8 °F)
Thermocouples (TC)	Type: K, J, T, E, L, U	typ. 0.25 °C (0.45 °F)
	Type: N, C, D	typ. 0.5 °C (0.9 °F)
	Type: S, B, R	typ. 1.0 °C (1.8 °F)
	Measuring range	Performance characteristics
Resistance transmitters (Ω)	10 to 400 Ω 10 to 2000 Ω	$\pm 0.04\ \Omega$ $\pm 0.8\ \Omega$
	Voltage transmitters (mV)	-20 to 100 mV

Sensor transmitter matching

RTD sensors are one of the most linear temperature measuring elements. Nevertheless, the output must be linearized. To improve temperature measurement accuracy significantly, the device enables the use of two methods:

- Callendar-Van Dusen coefficients (Pt100 resistance thermometer)
The Callendar-Van Dusen equation is described as:

$$R_T = R_0[1 + AT + BT^2 + C(T-100)T^3]$$

The coefficients A, B and C are used to match the sensor (platinum) and transmitter in order to improve the accuracy of the measuring system. The coefficients for a standard sensor are specified in IEC 751. If no standard sensor is available or if greater accuracy is required, the coefficients for each sensor can be determined specifically by means of sensor calibration.

- Linearization for copper/nickel resistance thermometers (RTD)
The polynomial equations for nickel are described as:

$$R_T = R_0[1 + AT + BT^2 + C(T-100)T^3]$$

The equations for copper, subject to temperature, are described as:

$$R_T = R_0(1 + AT)$$

T = -50 °C to 200 °C (-58 °F to 392 °F)

$$R_T = R_0[1 + AT + B(T+6.7) + CT^2]$$

T = -180 °C to -50 °C (-292 °F to -58 °F)

These coefficients A, B and C are used for the linearization of nickel or copper resistance thermometers (RTD). The exact values of the coefficients derive from the calibration data and are specific to each sensor.

Sensor transmitter matching using one of the above-named methods significantly improves the temperature measurement accuracy of the entire system. This is due to the fact that to calculate the temperature measured, the transmitter uses the specific data pertaining to the connected sensor instead of using the standardized sensor curve data.

Non-repeatability

As per EN 61298-2

Physical input measuring range of sensors		Non-repeatability
10 to 400 Ω	Cu10, Cu50, Cu100, Pt50, Pt100, Ni100, Ni120	15 mΩ
10 to 2000 Ω	Pt200, Pt500, Pt1000, Ni1000	100 ppm x measured value
-20 to 100 mV	Thermocouples type: C, D, E, J, K, L, N, U	4 μV
-5 to 30 mV	Thermocouples type: B, R, S, T	3 μV

Long-term stability

≤ 0.1 °C/year (≤ 0.18 °F/year) in reference operating conditions

Influence of ambient temperature (temperature drift)

Impact on accuracy when ambient temperature changes by 1 K (1.8 °F):	
Input 10 to 400 Ω	0.001% of the measured value, min. 1 mΩ
Input 10 to 2000 Ω	0.001% of the measured value, min. 10 mΩ
Input -20 to 100 mV	0.001% of the measured value, min. 0.2 μV
Input -5 to 30 mV	0.001% of the measured value, min. 0.2 μV

Typical sensitivity of resistance thermometers		
Pt: $0.00385 * R_{nom}/K$	Cu: $0.0043 * R_{nom}/K$	Ni: $0.00617 * R_{nom}/K$

Example Pt100: $0.00385 \times 100 \Omega/K = 0.385 \Omega/K$

Typical sensitivity of thermocouples					
B: $10 \mu V/K$	C: $20 \mu V/K$	D: $20 \mu V/K$	E: $75 \mu V/K$	J: $55 \mu V/K$	K: $40 \mu V/K$
L: $55 \mu V/K$	N: $35 \mu V/K$	R: $12 \mu V/K$	S: $12 \mu V/K$	T: $50 \mu V/K$	U: $60 \mu V/K$

Example of calculating the measured error with ambient temperature drift:

- Input temperature drift $\vartheta = 10 \text{ K}$ ($18 \text{ }^\circ\text{F}$), Pt100, measuring range 0 to $100 \text{ }^\circ\text{C}$ (32 to $212 \text{ }^\circ\text{F}$)
- Maximum process temperature: $100 \text{ }^\circ\text{C}$ ($212 \text{ }^\circ\text{F}$)
- Measured resistance value: 138.5Ω (DIN EN 60751) at maximum process temperature

Typical temperature drift in Ω : $(0.001\% \text{ of } 138.5 \Omega) * 10 = 0.01385 \Omega$

Conversion to Kelvin: $0.01385 \Omega / 0.385 \Omega/K = 0.04 \text{ K}$ ($0.054 \text{ }^\circ\text{F}$)

**Influence of reference point
(cold junction)**

Pt100 DIN EN 60751 Cl. B, internal reference point for thermocouples TC

Installation conditions

Installation instructions

- Mounting location:

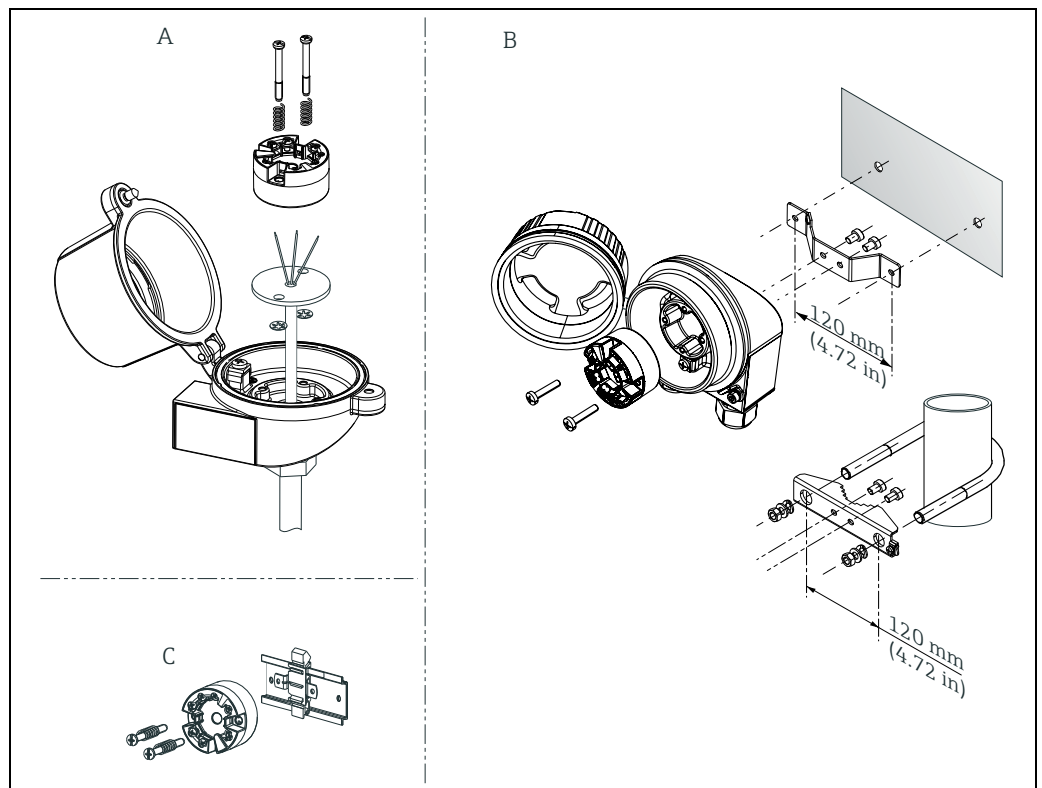

A: Terminal head as per DIN EN 50446 form B, direct installation onto insert with cable entry (middle hole 7 mm (0.28 in))

B: Separated from process in field housing, wall or pipe mounting

C: With DIN rail clip on mounting rail as per IEC 60715 (TH35)

- Orientation:
No restrictions

Environment conditions

Ambient temperature range	-40 to +85 °C (-40 to +185 °F), for hazardous areas see Ex documentation (XA, CD) and "Approvals" section.																						
Storage temperature	-40 to +100 °C (-40 to +212 °F)																						
Altitude	up to 4000 m (4374.5 yd) above mean sea level in accordance with IEC 61010-1, CSA 1010.1-92																						
Climate class	as per IEC 60654-1, Class C																						
Humidity	<ul style="list-style-type: none"> ■ Condensation as per IEC 60068-2-33 permitted ■ Max. rel. humidity: 95% as per IEC 60068-2-30 																						
Degree of protection	<ul style="list-style-type: none"> ■ IP00 with screw terminals. In the installed state, it depends on the terminal head or field housing used. ■ IP30 with spring terminals ■ IP66/67 when installed in field housing TA30A, TA30D or TA30H 																						
Shock and vibration resistance	10 to 2000 Hz for 5g as per IEC 60068-2-6																						
Electromagnetic compatibility (EMC)	<p>CE EMC compliance The device meets all of the requirements mentioned in IEC 61326-1, 2007 and NAMUR NE21:2006. This recommendation is a consistent determination whether the devices used in laboratories and in process control systems are immune to interference, thus increasing their functional safety.</p> <table border="1"> <tr> <td>ESD (electrostatic discharge)</td> <td>IEC 61000-4-2</td> <td>6 kV cont., 8 kV air</td> <td></td> </tr> <tr> <td>Electromagnetic fields</td> <td>IEC 61000-4-3</td> <td>0.08 to 4 GHz</td> <td>10 V/m</td> </tr> <tr> <td>Burst (fast transients)</td> <td>IEC 61000-4-4</td> <td>1 kV</td> <td></td> </tr> <tr> <td>Surge</td> <td>IEC 61000-4-5</td> <td>1 kV asym.</td> <td></td> </tr> <tr> <td>Conducted RF</td> <td>IEC 61000-4-6</td> <td>0.01 to 80 MHz</td> <td>10 V</td> </tr> </table>			ESD (electrostatic discharge)	IEC 61000-4-2	6 kV cont., 8 kV air		Electromagnetic fields	IEC 61000-4-3	0.08 to 4 GHz	10 V/m	Burst (fast transients)	IEC 61000-4-4	1 kV		Surge	IEC 61000-4-5	1 kV asym.		Conducted RF	IEC 61000-4-6	0.01 to 80 MHz	10 V
ESD (electrostatic discharge)	IEC 61000-4-2	6 kV cont., 8 kV air																					
Electromagnetic fields	IEC 61000-4-3	0.08 to 4 GHz	10 V/m																				
Burst (fast transients)	IEC 61000-4-4	1 kV																					
Surge	IEC 61000-4-5	1 kV asym.																					
Conducted RF	IEC 61000-4-6	0.01 to 80 MHz	10 V																				
Measuring category	Measuring category II as per IEC 61010-1. The measuring category is provided for measuring on power circuits that are directly connected electrically with the low-voltage network.																						
Degree of contamination	Pollution degree 2 as per IEC 61010-1.																						

Mechanical construction

Design, dimensions

Specifications in mm (in)
Head transmitter

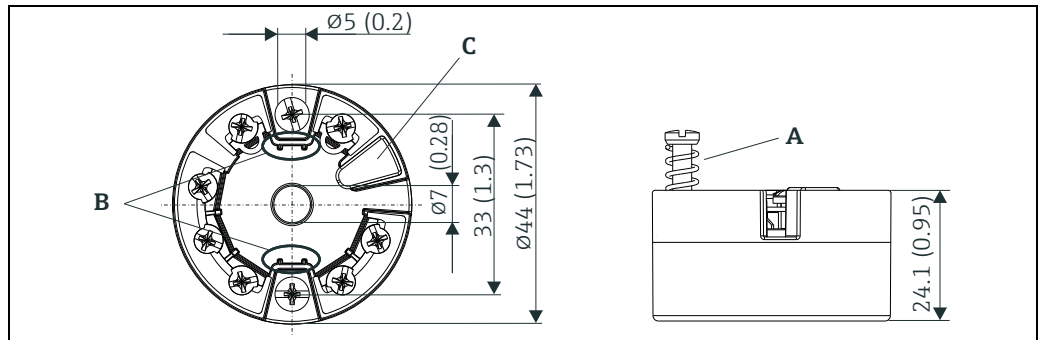

A0007301

Model with screw terminals

Pos. A: Spring range $L \geq 5$ mm (not applicable to US - M4 mounting screws)

Pos. B: Fixing elements for detachable measured value display

Pos. C: Interface for contacting measured value display

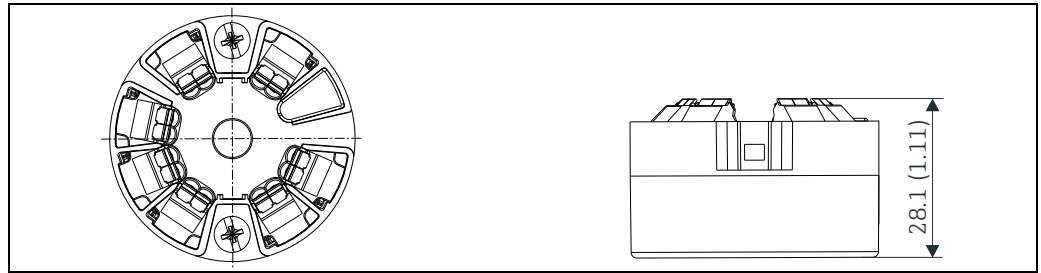

A0007672

Model with spring terminals. The same dimensions except for height of housing.

Field housings

All terminal heads have an internal shape and size in accordance with DIN EN 50446, flat face and a thermometer connection of M24x1.5. Cable glands: M20x1.5

TA30A	Specification
<p style="text-align: right; font-size: small;">A0009820</p>	<ul style="list-style-type: none"> ■ Two cable entries ■ Temperature: -50 °C to +150 °C (-58 °F to +302 °F) without cable gland ■ Material: aluminum, polyester powder coated ■ Seals: silicone ■ Cable entry incl. glands: ½"NPT and M20x1.5 ■ Head color: blue RAL 5012 ■ Cap color: gray RAL 7035 ■ Weight: 330 g (11.64 oz)

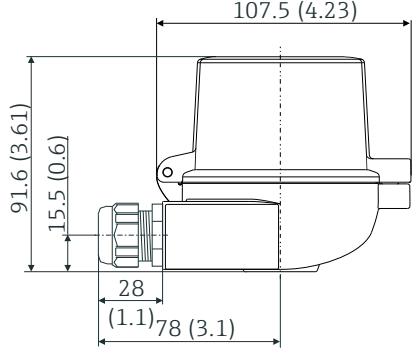
TA30A with display window in cover	Specification
 <p>A0009821</p>	<ul style="list-style-type: none"> ■ Two cable entries ■ Temperature: -50 °C to +150 °C (-58 °F to +302 °F) without cable gland ■ Material: aluminum, polyester powder coated ■ Seals: silicone ■ Cable entry incl. glands: ½"NPT und M20x1.5 ■ Head color: blue RAL 5012 ■ Cap color: gray RAL 7035 ■ Weight: 420 g (14.81 oz)

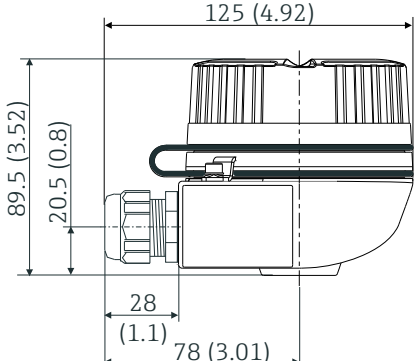
TA30H	Specification
 <p>A0009832</p>	<ul style="list-style-type: none"> ■ Flameproof (XP) version, explosion-protected, captive screw cap, with two cable entries ■ Temperature: -50 °C to +150 °C (-58 °F to +302 °F) for rubber seal without cable gland (observe max. permitted temperature of the cable gland!) ■ Material: aluminum; polyester powder coated ■ Cable entry glands: ½"NPT, M20x1.5 ■ Head color: blue RAL 5012 ■ Cap color: gray RAL 7035 ■ Weight: 640 g (22.6 oz)

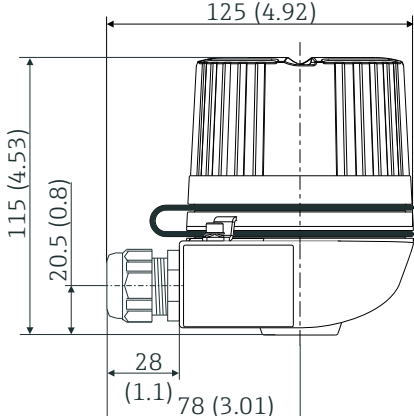
TA30H with display window in cover	Specification
 <p>A0009831</p>	<ul style="list-style-type: none"> ■ Flameproof (XP) version, explosion-protected, captive screw cap, with two cable entries ■ Temperature: -50 °C to +150 °C (-58 °F to +302 °F) for rubber seal without cable gland (observe max. permitted temperature of the cable gland!) ■ Material: aluminum; polyester powder coated ■ Cable entry glands: ½"NPT, M20x1.5 ■ Head color: blue RAL 5012 ■ Cap color: gray RAL 7035 ■ Weight: 860 g (30.33 oz)

TA30D	Specification
	<ul style="list-style-type: none"> ■ Two cable entries ■ Temperature: -50 °C to +150 °C (-58 °F to +302 °F) without cable gland ■ Material: aluminum, polyester powder coated ■ Seals: silicone ■ Cable entry incl. glands: ½"NPT, M20x1.5 ■ Two head transmitters can be mounted. In the standard version, one transmitter is mounted in the terminal head cover and an additional terminal block is installed directly on the insert. ■ Head color: blue RAL 5012 ■ Cap color: gray RAL 7035 ■ Weight: 390 g (13.75 oz)

Maximum ambient temperature for cable glands and fieldbus connectors	
Type	Temperature range
Cable gland polyamide ½" NPT, M20x1.5 (non-Ex)	-40...+100 °C (-40...+212 °F)
Cable gland polyamide M20x1.5 (for dust ignition-proof area)	-20...+95 °C (-4...+203 °F)
Cable gland brass ½" NPT, M20x1.5 (for dust ignition-proof area)	-20...+130 °C (-4...+266 °F)
Fieldbus connector (M12x1 PA, 7/8" FF)	-40...+105 °C (-40...+221 °F)

Weight

- Head transmitter: approx. 40 to 50 g (1.4 to 1.8 oz)
- Field housing: see specifications

Material

All materials used are RoHS-compliant.

Head transmitter

- Housing: Polycarbonate (PC), complies with UL94 HB flammability standard (HB: horizontal burning test)
- Terminals
 - Screw terminals: Nickel-plated brass and gold-plated contact
 - Spring terminals: Tin-plated brass, contact spring V2A
- Potting: WEVO PU 403 FP / FL, according to UL94 V0 flammability standard (V0: vertical burning test)

Field housing: see specifications

Terminals

Choice of screw or spring terminals (see "Design, dimensions" diagram) for sensor and fieldbus wires:

Terminals version	Wire version	Conductor cross-section
Screw terminals (with latches at the fieldbus terminals for easy connection of a handheld terminal, e.g. FieldXpert, FC475)	Rigid or flexible	≤ 2.5 mm ² (14 AWG)
Spring terminals Stripped length = min. 10 mm (0.39 in)	Rigid or flexible	0.2 mm ² to 1.5 mm ² (24...16 AWG)
	Flexible with wire-end ferrules without plastic ferrule	0.25 mm ² to 1.5 mm ² (24...16 AWG)
	Flexible with wire-end ferrules with plastic ferrule	0.25 mm ² to 0.75 mm ² (24...18 AWG)



No ferrules have to be used when connecting flexible wires to spring terminals.

Human interface

Display and operating elements

There are no display or operating elements present at the head transmitter. Optional the plug-on display TID10 can be used in connection with the head transmitter. It will display information regarding the actual measured value and the measurement point identification. In the event of a fault in the measurement chain this will be displayed in inverse color showing the channel ident and diagnostics code. DIP-switches can be found on the rear of the display. This enables the hardware set-up such as the FOUNDATION Fieldbus™ hardware write protection.

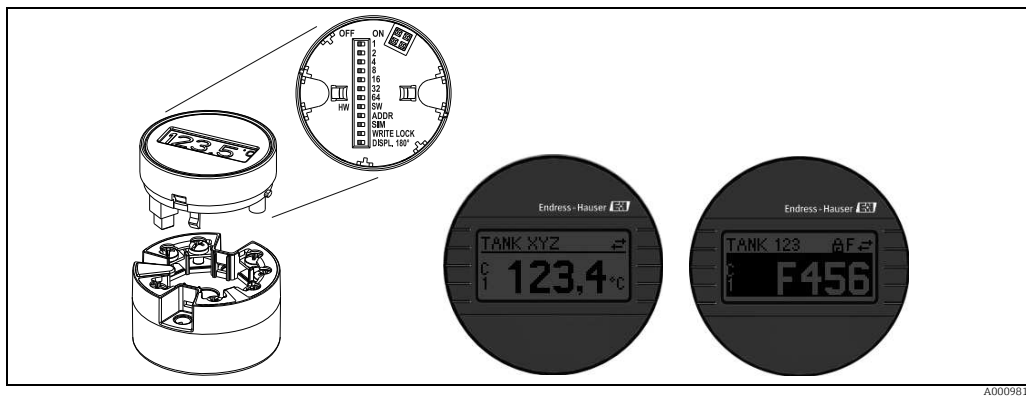

Pluggable display TID10

A0009818

If the transmitter is installed in a field housing and used with a display, a housing with glass window needs to be used.

Remote operation

The configuration of FOUNDATION Fieldbus™ functions and of device-specific parameters is performed via fieldbus communication. Special configuration systems provided by various manufacturers are available for this purpose. For further information please contact your local Endress+Hauser sales center.

Certificates and approvals

CE-Mark

The device meets the legal requirements of the EC directives. Endress+Hauser confirms that the device has been successfully tested by applying the CE mark.

Hazardous area approvals

ATEX approval

TMT85		ATEX II 1G	Ex ia IIC	T6/T5/T4
Power supply (Terminals + and -)		$U_i \leq 17.5 \text{ V DC}$ $I_i \leq 500 \text{ mA}$ $C_i \leq 5 \text{ nF}$ $L_i = \text{negligibly small}$	or	$U_i \leq 24 \text{ V DC}$ $I_i \leq 250 \text{ mA}$
Suitable for connecting to a fieldbus system as per the FISCO/FNICO model				
Sensor circuit (Terminals 3 to 7)		$U_0 \leq 7.2 \text{ V DC}$ $I_0 \leq 25.9 \text{ mA}$ $P_0 \leq 46.7 \text{ mW}$ $C_i = \text{negligibly small}$ $L_i = \text{negligibly small}$		
Max. connection data	Ex ia IIC Ex ia IIB Ex ia IIA	$L_0 = 20 \text{ mH}$ $L_0 = 50 \text{ mH}$ $L_0 = 100 \text{ mH}$	$C_0 = 0.7 \text{ }\mu\text{F}$ $C_0 = 4.6 \text{ }\mu\text{F}$ $C_0 = 6.0 \text{ }\mu\text{F}$	

TMT85	ATEX II 1G	Ex ia IIC	T6/T5/T4
Temperature range	T6 T5 T4	Zone 1, 2: Ta = -40 °C to +55 °C (-40 °F to 130 °F) Ta = -40 °C to +70 °C (-40 °F to 158 °F) Ta = -40 °C to +85 °C (-40 °F to 185 °F)	Zone 0: Ta = -20 °C to +40 °C (-4 °F to 104 °F) Ta = -20 °C to +50 °C (-4 °F to 122 °F) Ta = -20 °C to +60 °C (-4 °F to 140 °F)

Application:

- Equipment category: potentially explosive gas and air mixtures (G)
- Category 1 zone 0, 1 or 2



For zone 0: potentially explosive steam and air mixtures may only occur under following atmospheric conditions:

- 20 °C ≤ Ta ≤ +60 °C (-4 °F ≤ Ta ≤ +140 °F)
- 0.8 bar ≤ p ≤ 1.1 bar (11.6 psi ≤ p ≤ 16 psi)

TMT85		ATEX <ul style="list-style-type: none"> II 2G Ex d IIC T6...T4 Gb II 2D Ex tb IIIC T85 °C...T105 °C Db IEC <ul style="list-style-type: none"> Ex d IIC T6...T4 Gb Ex tb IIIC T85 °C...T105 °C Db
Power supply (terminals + and -)		U ≤ 35 V DC
Output		FOUNDATION Fieldbus™ Current consumption ≤ 11 mA
Temperature range	T6 T5 T4	-40 °C ≤ Ta ≤ +65 °C -40 °C ≤ Ta ≤ +80 °C -40 °C ≤ Ta ≤ +85 °C
Maximum surface temperature housing	T85 °C T100 °C T105 °C	-40 °C ≤ Ta ≤ +65 °C -40 °C ≤ Ta ≤ +80 °C -40 °C ≤ Ta ≤ +85 °C

TMT85		ATEX II 3G Ex nA II T6/T5/T4 ATEX II 3D
Power supply (terminals + and -)		U ≤ 35 V DC
Output		FOUNDATION Fieldbus™ Current consumption ≤ 11 mA
Temperature range	T6 T5 T4	Ta = -40 °C to +55 °C (-40 °F to 130 °F) Ta = -40 °C to +70 °C (-40 °F to 158 °F) Ta = -40 °C to +85 °C (-40 °F to 185 °F)

Application (ATEX II 3G Ex nA II T6/T5/T4):

- Equipment category: potentially explosive gas and air mixtures (G)
- Category zone 2

Application (ATEX II 3D):

- Equipment category: potentially explosive dust and air mixtures (D)
- Category zone 22

FM approval

Labeling: IS / I / 1 / ABCD / T4, Entity* or FISCO*;

I / 0 / AEx ia IIC / T4 Ta, Entity* or FISCO*

NI / I / 2 / ABCD / T4, NIFW* or FNICO*;

FM XP, NI, DIP I, II, III / 1+2 / A-G

*= Entity, FISCO, NIFW and FNICO parameters in accordance with control drawings (CD)

Application:

- Intrinsic safety
- Non-incendive

For connection data see table on ATEX approval ATEX II 1G

CSA approval (Canadian Standard Association)

Labeling:

Class I, Div. 1, Groups A, B, C, D, Entity* or FISCO*;

Ex ia IIC

Class I, Div.2, Groups A, B, C, D, NIFW* or FNICO*;

Ex nA IIC

CSA XP, NI, DIP I, II, III / 1+2 / A-G

*= Entity, FISCO, NIFW and FNICO parameters in accordance with control drawings (CD)

Application:

- Intrinsic safety
- Non-incendive

For connection data see table on ATEX approval ATEX II 1G

For further details on the available Ex versions (ATEX, CSA, FM, etc.), please contact your nearest Endress+Hauser sales organisation. All relevant data for hazardous areas can be found in separate Ex documentation. If required, please request copies from us or your Endress+Hauser sales organisation.

UL Recognized component to UL61010-1

Other standards and guidelines

- IEC 60529:
Degrees of protection through housing (IP code)
- IEC 61158-2:
Fieldbus standard
- IEC 61326-1:2007:
Electromagnetic compatibility (EMC requirements)
- IEC 60068-2-27 and IEC 60068-2-6:
Shock and vibration resistance
- NAMUR
International user association of automation technology in process industries

Certification FOUNDATION Fieldbus™

The temperature transmitter is certified and registered by the Fieldbus Foundation. The device thus meets all the requirements of the specifications following:

- Certified according to FOUNDATION Fieldbus™ specification
- The device meets all the specifications of the FOUNDATION Fieldbus™ H1
- Interoperability Test Kit (ITK), revision status 6.0.1 (device certification no. available on request): the device can also be operated with certified devices of other manufacturers
- Physical layer conformance test of the FOUNDATION Fieldbus™ (FF-830 FS 2.0)

Ordering information

Detailed ordering information is available from the following sources:

- In the Product Configurator on the Endress+Hauser website:
www.endress.com → Select country → Instruments → Select device → Product page function:
Configure this product
- From your Endress+Hauser Sales Center:
www.endress.com/worldwide

Product Configurator - the tool for individual product configuration:

- Up-to-the-minute configuration data
- Depending on the device: Direct input of measuring point-specific information such as measuring range or operating language
- Automatic verification of exclusion criteria
- Automatic creation of the order code and its breakdown in PDF or Excel output format
- Ability to order directly in the Endress+Hauser Online Shop

Accessories

The following accessories are contained in the scope of delivery:

- Multi-language Brief Operating Instructions as hard copy
- Supplementary documentation ATEX:
 - ATEX Safety instructions (XA), Control Drawings (CD)
- Operating Instructions on CD-ROM
- Mounting material for head transmitter
- Optional mounting material for field housings (pipe or wall mounting)

Optional accessories

Type	Order code
Display TID10 for Endress+Hauser head transmitters iTEMP® TMT8x, pluggable	TID10-xx
TID10 service cable for remote operation of the display for service work; length 40 cm	71086650
Field housing TA30x for Endress+Hauser head transmitter	TA30x-xx
Adapter for DIN rail mounting, DIN rail clip as per IEC 60715 (TH35)	51000856
Standard - DIN mounting set (2 screws + springs, 4 securing disks and 1 display connector cover)	71044061
US - M4 mounting screws (2 screws M4 and 1 display connector cover)	71044062
Fieldbus connector (FF): <ul style="list-style-type: none"> ■ NPT$\frac{1}{2}$" → 7/8" ■ M20 → 7/8" 	71082009 71082008
Stainless steel wall mounting bracket for field housing TA30x	71123339
Stainless steel pipe mounting bracket for field housing TA30x	71123342



Service-specific accessories

Accessories	Description
Applicator	<p>Software for selecting and sizing Endress+Hauser measuring devices:</p> <ul style="list-style-type: none"> ■ Calculation of all the necessary data for identifying the optimum measuring device: e.g. pressure loss, accuracy or process connections. ■ Graphic illustration of the calculation results <p>Administration, documentation and access to all project-related data and parameters over the entire life cycle of a project.</p> <p>Applicator is available:</p> <ul style="list-style-type: none"> ■ Via the Internet: https://wapps.endress.com/applicator ■ On CD-ROM for local PC installation.
Konfigurator ^{+temperature}	<p>Software for selecting and configuring the product depending on the measuring task, supported by graphics. Includes a comprehensive knowledge database and calculation tools:</p> <ul style="list-style-type: none"> ■ For temperature competence ■ Quick and easy design and sizing of temperature measuring points ■ Ideal measuring point design and sizing to suit the processes and needs of a wide range of industries <p>The Konfigurator is available: On request from your Endress+Hauser sales office on a CD-ROM for local PC installation.</p>

W@M	<p>Life cycle management for your plant</p> <p>W@M supports you with a wide range of software applications over the entire process: from planning and procurement, to the installation, commissioning and operation of the measuring devices. All the relevant device information, such as the device status, spare parts and device-specific documentation, is available for every device over the entire life cycle.</p> <p>The application already contains the data of your Endress+Hauser device. Endress+Hauser also takes care of maintaining and updating the data records.</p> <p>W@M is available:</p> <ul style="list-style-type: none"> ▪ Via the Internet: www.endress.com/lifecyclemanagement ▪ On CD-ROM for local PC installation.
-----	---

FieldCare	<p>FDT-based plant asset management tool from Endress+Hauser.</p> <p>It can configure all smart field units in your system and helps you manage them. By using the status information, it is also a simple but effective way of checking their status and condition.</p> <p> For details: see Operating Instructions BA00027S and BA00059S</p>
-----------	---

System components

Accessories	Description
RID14	<p>The 8-channel digital indicator displays the measured values, calculated values and status information of the fieldbus users in a FOUNDATION Fieldbus™ network. In the listener mode, the device listens to the set fieldbus addresses and displays their specific values. Furthermore, values available on the bus can be displayed via function block interconnection.</p> <p> For details: see the Technical Information document TI145R/09/en and Operating Instructions BA282R/09/en</p>
RID16	<p>The field indicator with 8 channels and FOUNDATION Fieldbus™ protocol displays the measured values, calculated values and status information of the fieldbus users in a FOUNDATION Fieldbus™ network. In the listener mode, the device listens to the set fieldbus addresses and displays their specific values. Furthermore, values available on the bus can be displayed via function block interconnection.</p> <p> For details: see the Technical Information document TI146R/09/en and Operating Instructions BA284R/09/en</p>

Documentation

- Operating instructions "iTEMP® TMT85" (BA00251R/09/en) on CD-ROM and associated Brief Operating Instructions "iTEMP® TMT85" (KA00252R/09) as hard copy
- Operating instructions "Guideline FOUNDATION Fieldbus Function Blocks" (BA00062S/04/en)
- Ex supplementary documentation:
 - ATEX II 1G Ex ia IIC: XA069R/09/a3
 - ATEX II 3G Ex nA II: XA073R/09/a3
 - ATEX II 3D Ex tD A22: XA074R/09/a3
 - ATEX II 2(1)G Ex ia IIC: XA01012T/09/a3
 - ATEX II 2G Ex d IIC and ATEX II 2D Ex tb IIC: XA01007T/09/a3

www.addresses.endress.com
