



Level



Pressure



Flow



Temperature

Liquid
Analysis

Registration

Systems
Components

Services



Solutions

Technical Information

TH27

Hygienic thermowell assemblies with spring loaded RTD insert



Areas of application

The TH27 temperature sensors are RTD assemblies installed in hygienic thermowells and designed for use in dairy, food & beverage, pharmaceutical, biotech and sterile process technology plant.

- Temperature dryers in food processes
- Pasteurization
- Heat exchangers
- Material storage tanks
- Cheese vats
- Brewhouse / cellar
- Cookers / freezers
- Dehydrator
- Fermentor / bio-reactor control
- CIP/SIP systems

Your benefits

- Highest reliability in critical process monitoring.
- Smart switch over for high measurement point availability.
- Avoid plant shut down due to sensor breakdown, drifting, and corrosion.
- Meets all hygienic standards.
- Easy validation, conforming to ASME BPE 2005.
- Perfect match for all applications when integrated with head or field transmitter.
- Reduced cost to install as all units arrive as a complete assembly.
- 2 kV improved galvanic isolation for better signal and integrity.
- A single model number includes sensor, thermowell and transmitter assembly for a complete point solution.
- All iTEMP® transmitters provide long term stability ≤ 0.05 % per year.

Function and system design

Measuring principle

The RTD (Resistance Temperature Detector) element consists of an electrical resistance with a value of 100 Ω at 0 °C (called Pt100, in compliance with IEC 60751), which increases at higher temperatures according to a coefficient characteristic of resistor material (platinum). In industrial thermometers that comply with the IEC 60751 standard, the value of this coefficient is $\alpha = 0.00385 \text{ } ^\circ\text{C}^{-1}$, calculated between 0 and 100 °C (32 and 212 °F).

Measuring system

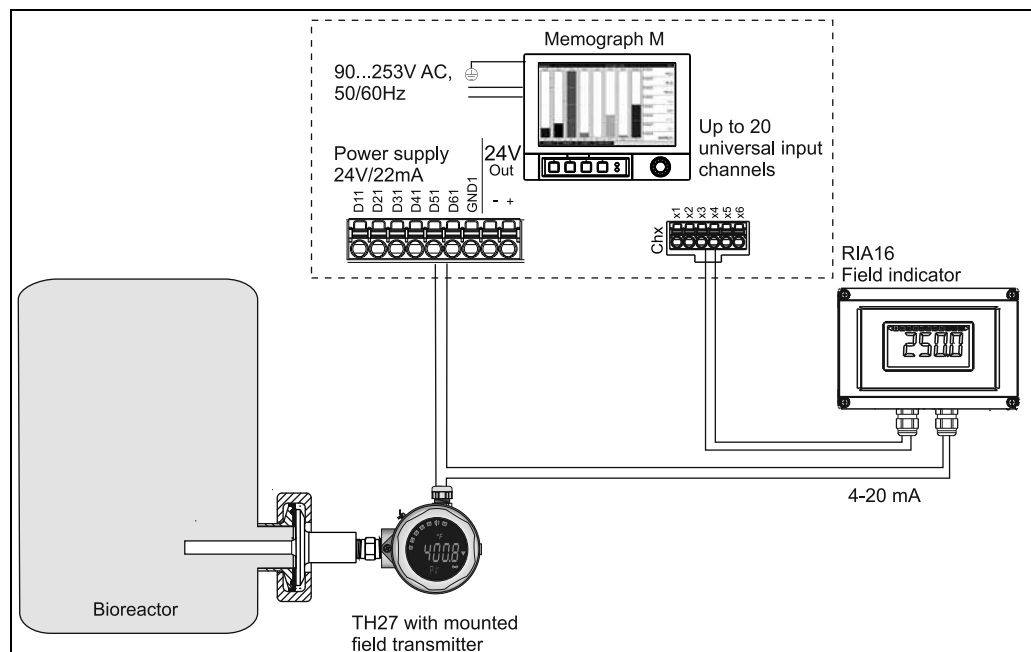

Example of an application of the temperature assembly

A0009308

Memograph M, RSG40

Multichannel data recording system with multicolored TFT display (170 mm/7 in screen size), galvanically isolated universal inputs (U, I, TC, RTD, pulse, frequency), digital input, transmitter power supply, limit relay, communication interfaces (USB, Ethernet, RS232/485), internal SD memory, external SD card and USB stick. 100 ms scan rate for all channels. ReadWin 2000 PC software for comprehensive device configuration and data evaluation. Details see Technical Information (see "Documentation").

RIA16 Field indicator

The field indicator records an analog measuring signal and shows this on the display. The LCD display shows the currently measured value digitally and as a bargraph with limit value violation signalling. The indicator is looped into the 4 to 20 mA circuit and obtains the required energy from there. The measuring range, decimal point and offset of the indicator can be configured comfortably by means of three keys in the device with the housing open or by means of a PC with the FieldCare PC software. Details see Technical Information (see "Documentation").

Equipment architecture

The single and duplex element RTDs are designed to measure temperature in food, dairy and pharmaceutical applications. These RTDs are specifically designed for use in two different process temperature ranges and they will provide accurate and repeatable temperature measurement through a broad temperature range of -200 to 600 °C (-328 to 1112 °F). Low range thin film RTDs -50 to 200 °C (-58 to 392 °F) are constructed using silver plated and copper internal leads, PTFE wire insulations with potting compounds to resist moisture penetration. High range RTDs -200 to 600 °C (-328 to 1112 °F) are constructed with nickel internal leads inside swaged MgO insulated cables to allow higher temperature measurements at the RTD element and to provide higher temperature lead protection along the sheath.

Measurement range

Construction	Model code (class and type of sensor)	max. range
Low temperature range	TH27-____ (C/G/L) _____	-50 to 200 °C (-58 to 392 °F)

Construction	Model code (class and type of sensor)	max. range
High temperature range	TH27-_____(D/H/M)_____	-200 to 600 °C (-328 to 1112 °F)



Note!

Options L, M are duplex platinum elements of two sensors inside the same sheath.

Calibration specifications

3 point sensor calibration		
-40 to 0 °C	0 to 100 °C	+40 to 215 °C
-40 to 32 °F	32 to 212 °F	104 to 420 °F
Minimum length requirements for calibrated sensors = 6 in		



Note!

Use option code 'B' (Block: additional option 2) for calibration, the three temperature points need to be specified in 5 °C (9 °F) increments.

The manufacturer provides comparison temperature calibrations from -40 to +215 °C (-40 to +420 °F) on the International Temperature Scale (ITS) of 1990. Calibrations are traceable to standards maintained by the National Institute of Standards and Technology (NIST). Calibration services are in conformance with ASTM E220, IEC 17025 and ANSI/NCSS Z540-1-1994. The report of calibration is referenced to the serial number of the assembly.

Three point calibrations are provided, given that the specified temperatures are within the recommended range and the minimum length requirements are met as specified. The minimum length is based on overall length 'x' of the spring loaded insert.

Electronics

Family of temperature transmitters

Measurement assemblies with iTEMP® transmitters are an installation ready solution to improve the functionality of temperature measurement by increasing accuracy and reliability when compared to direct wired sensors. Overall installation costs are lower than with direct wired sensors, since an inexpensive pair of signal (4 to 20 mA) wires can be run over long distances.

PC programmable devices TMT180 and TMT181

PC programmable head transmitters offer you extreme flexibility and help control costs with the ability to stock one device and program it for your needs. Regardless of your choice of output, all iTEMP® transmitters can be configured quickly and easily with a PC. To help you with this task, Endress+Hauser offers free software ReadWin® 2000 which can be downloaded from our website. Go to www.readwin2000.com to download ReadWin® 2000 today. For details see Technical Information.

HART® TMT182 head transmitter

HART® communication is all about easy, reliable data access and getting better information more inexpensively. iTEMP® transmitters integrate seamlessly into your existing control system and provide painless access to preventative diagnostic information.

Configuration with a DXR275 or 375 hand-held or a PC with configuration program (FieldCare, ReadWin® 2000) or configure with AMS or PDM. For details, see Technical Information.

PROFIBUS® PA TMT84 head transmitter

Universally programmable head transmitter with PROFIBUS®-PA fieldbus communication. Converting various input signals into a digital output signal. High accuracy in the total ambient temperature range. Swift and easy operation, visualization and maintenance using a PC direct from the control panel, e. g. using operating software such as FieldCare, Simatic PDM or AMS. DIP switch for address setting, makes start up and maintenance safe and reliable. For details, see Technical Information.

FOUNDATION Fieldbus™ TMT85 head transmitter

Universally programmable head transmitter with FOUNDATION Fieldbus™ communication. Converting various input signals into a digital output signal. High accuracy in the total ambient temperature range. Swift and easy operation, visualization and maintenance using a PC direct from the control panel, e. g. using operating software such as ControlCare from Endress+Hauser or the NI Configurator from National Instruments.

Benefits are: dual sensor input, highest reliability in harsh industrial environments, mathematic functions, thermometer drift monitoring, sensor back-up functionality, sensor diagnosis functions and sensor-transmitter matching by accepting Callendar Van Dusen constants. For details, see Technical Information.

Field transmitter TMT162 - Dual compartment housing

Field transmitter with HART® communication, FOUNDATION Fieldbus™ protocol and blue backlit display. Can be read easily from a distance, in sunlight and at night. Large measurement value, bargraph and fault indication display. Benefits are: dual sensor input, highest reliability in harsh industrial environments, mathematic functions, thermometer drift monitoring, sensor back-up functionality, corrosion detection and sensor transmitter matching by accepting Callendar Van Dusen constants. For details, see Technical Information.

Performance characteristics**Response time**

63% response time per ASTM E644

RTD assembly TH15 without thermowell

Construction	RTD insert ø ¼"
High temperature range	3 s
Low temperature range	9 s



Note!

Response time for the sensor assembly without transmitter.

Response time examples for RTD assemblies with thermowell TH27

Construction	Stepped thermowell	Stepped thermowell with thermoconductive paste
High temperature range	20 s	10 s
Low temperature range	25 s	15 s



Note!

Response times for RTD assemblies with thermowell are provided for general design guidance without transmitter.

When the temperature of a process media changes, the output signal of a RTD assembly follows this change after a certain time delay. The physical cause is the time related to heat transfer from the process media through the thermowell and the insert to the sensor element (RTD). The manner in which the reading follows the change in temperature of the assembly over time is referred to as the response time. Variables that influence or impact the response time are:

- Wall thickness of thermowell
- Spacing between RTD insert and thermowell
- Sensor packaging
- Process parameters such as media, flow velocity, etc.

Maximum measured error

RTD corresponding to IEC 60751

Class	max. Tolerances (°C)
A	$\pm(0.15 + 0.002 \cdot t)$, Temperature range: -100 °C to 450 °C
B	$\pm(0.3 + 0.005 \cdot t)$, Temperature range: -200 °C to 600 °C

1) $|t|$ = absolute value °C



Note!

For measurement errors in °F, calculate using equation above in °C, then multiply the outcome by 1.8.

Measurement accuracy transmitter

TMT180 Pt100 PCP	TMT181 multi-functional PCP	TMT182 HART®	TMT162 FF, TMT85 FF, TMT84 PA	Field transmitter TMT1x2 HART®	
				Accuracy	
				Digital	D/A ²
0.2 °C (0.36 °F) or 0.08% ¹	0.2 °C (0.36 °F) or 0.08% ²	0.2 °C (0.36 °F) or 0.08% ²	0.1 °C (0.18 °F)	0.1 °C (0.18 °F)	0.02%

1) % is related to the adjusted measurement range (the larger value applies)

2) % relates to the set span. Accuracy = digital + D/A accuracy

Transmitter long-term stability

≤ 0.1 °C/year (≤ 0.18 °F / year) or $\leq 0.05\%$ / year

Data under reference conditions; % relates to the set span. The larger value applies.

Insulation resistance

Insulation resistance ≥ 100 M Ω at ambient temperature.

Insulation resistance between each terminal and the sheath is tested with a voltage of 100 V DC.

Self heating

RTD elements are not self-powered and require a small current be passed through the device to provide a voltage that can be measured. Self-heating is the rise of temperature within the element itself, caused by the current flowing through the element. This self-heating appears as a measurement error and is affected by the thermal conductivity and velocity of the process being measured; it is negligible when an Endress+Hauser iTEMP® temperature transmitter is connected.

Sensor current

Sensor current of Endress+Hauser iTEMP® transmitters

Transmitter type	Sensor current
TMT180 & TMT181 PCP	≤ 0.6 mA
TMT182 HART®	≤ 0.2 mA
TMT84 PROFIBUS®-PA	≤ 0.3 mA
TMT85 FF	
TMT162 HART®, FF Field transmitter	
TMT142 HART® Field transmitter	

Galvanic isolation

Galvanic isolation of Endress+Hauser iTEMP® transmitters (input/output)

Transmitter type	Galvanic isolation
TMT181 PCP	U = 3.75 kV AC

Transmitter type	Galvanic isolation
TMT182 HART®	U = 2 kV AC
TMT84 PROFIBUS® PA	
TMT85 FF	
TMT162 HART®, FF Field transmitter	
TMT142 HART® Field transmitter	

Wiring

Electrical connection cables must comply with 3-A® standard, must be smooth, corrosion resistant and cleanable.

Wiring diagrams

Type of sensor connection

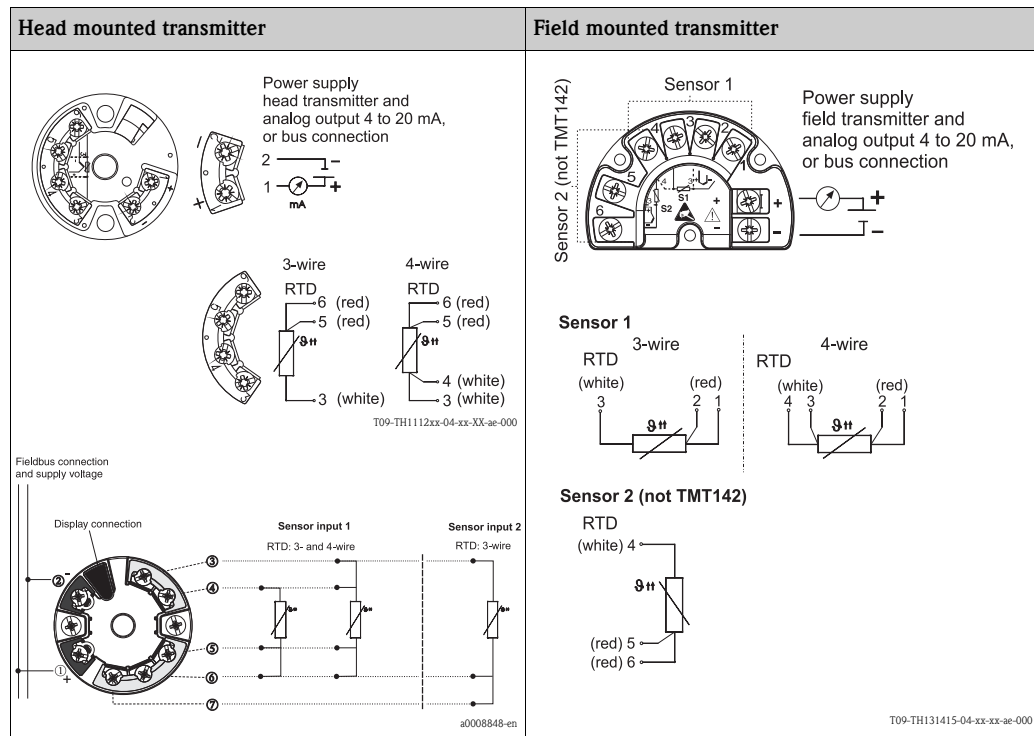

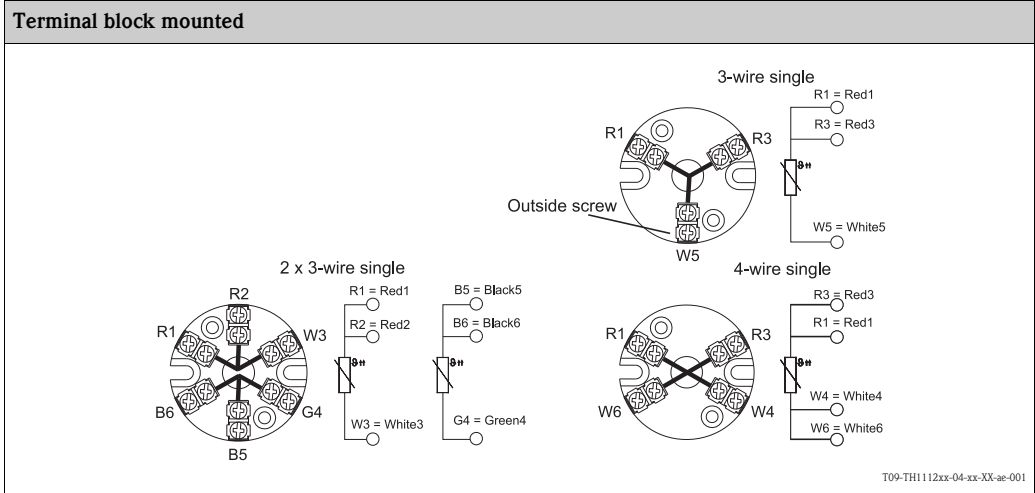

Note!

The blocks and transmitters are shown as they sit inside the heads in reference to the conduit opening.

Wire specifications

24AWG, 19 strand silver plated copper with 0.010" PTFE extruded outer.

Electrical connection
Flying leads, standard 3" for wiring in connection head, head mounted transmitter or terminal block mounted
Flying leads, 5½" for wiring with field transmitter TMT162 or TMT142 assemblies

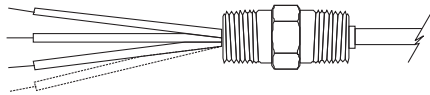
Design of leads	
Flying leads 3" or 5½" with brass crimped sleeves	

Installation conditions

Orientation

No restrictions, but self draining. If applicable leak detection hole must be at the lowest point.

Installation instructions

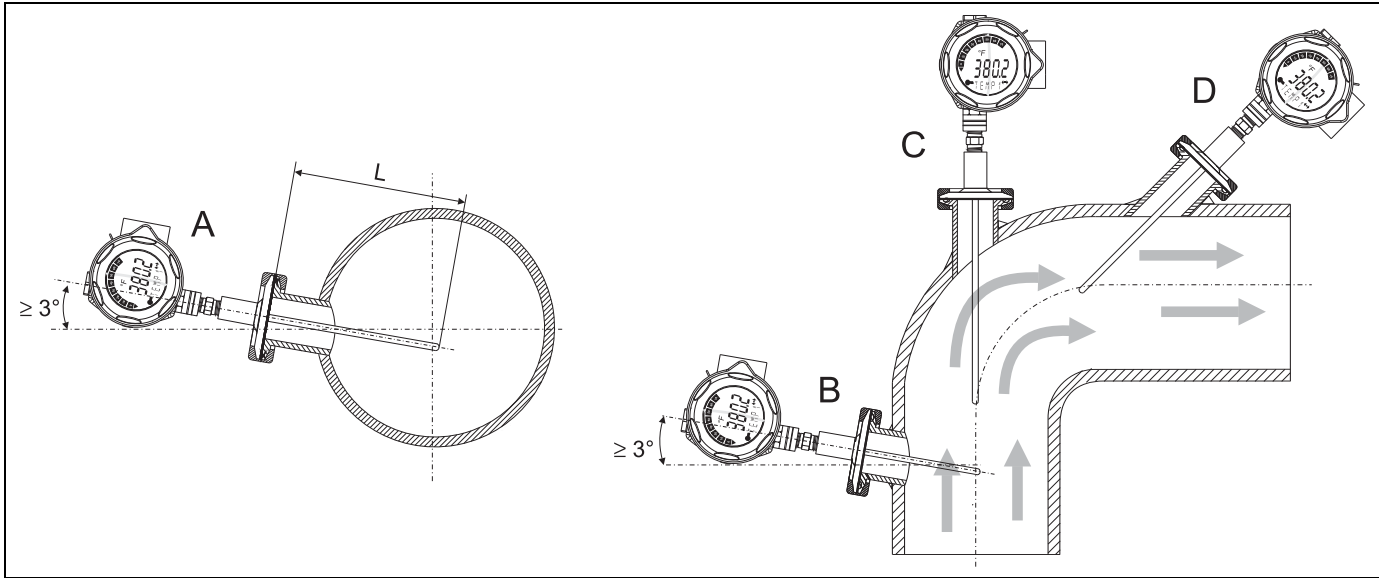

General installation solutions

A - B: In pipes with a small cross section the sensor tip should reach or extend slightly past the center line of the pipe (= L). Installation with minimal 3° inclination because of self draining.

C - D: Tilted installation

Care should be taken by the user in the execution of the welding on the process side (suitable weld material, welding radius > 3.2 mm, absence of pits, folds, crevices, ...). As a general rule, the thermometers should be installed in such a way that does not adversely affect their cleanability (3-A® requirements must be adhered to).

Immersion

Minimum immersion per ASTM E644, $\Delta T \leq 0.05 \text{ } ^\circ\text{C}$ (0.09 °F)

Immersion RTD assembly TH15 without thermowell

Construction	RTD Insert $\varnothing \frac{1}{4}$ " Minimum Immersion (in)
High temperature range	1 ¼"
Low temperature range	¾"

For temperature assembly TH27 with thermowell, the minimum immersion is the depth to which the thermowell is immersed in the medium, measured from the tip. To minimize errors from ambient temperature the following minimum immersion lengths are recommended:

Construction	Minimum Immersion (in)
½" straight thermowell	4"
½" reduced thermowell	2½"

Environmental conditions

Ambient temperature

Housing without head-mounted transmitter

- Aluminum pressure die-cast housing -40 to 150 °C (-40 to 300 °F)
- Plastic housing -40 to 85 °C (-40 to 185 °F)
- Deep drawn SS housing without display -40 to 150 °C (-40 to 300 °F)

Housing with head-mounted transmitter

- -40 to 85 °C (-40 to 185 °F)

Field transmitter without display

- -40 to 85 °C (-40 to 185 °F)

Shock and vibration resistance 4G / 2 to 150 Hz as per IEC 60 068-2-6

Process conditions

Thermowells are used in measuring the temperature of a moving fluid in a conduit, where the stream exerts an appreciable force. The limiting value for the thermowells is governed by the temperature, the pressure and the speed of the medium, the immersion length, the materials of the thermowells and the medium, etc.

Calculations for stress and vibration of thermowells can be done according to ASME PTC 19.3-1974 standard, please consult Endress+Hauser.

Mechanical construction

Design, dimensions

All dimensions in inches. For the values related to this graphic please refer to the tables and equations below.

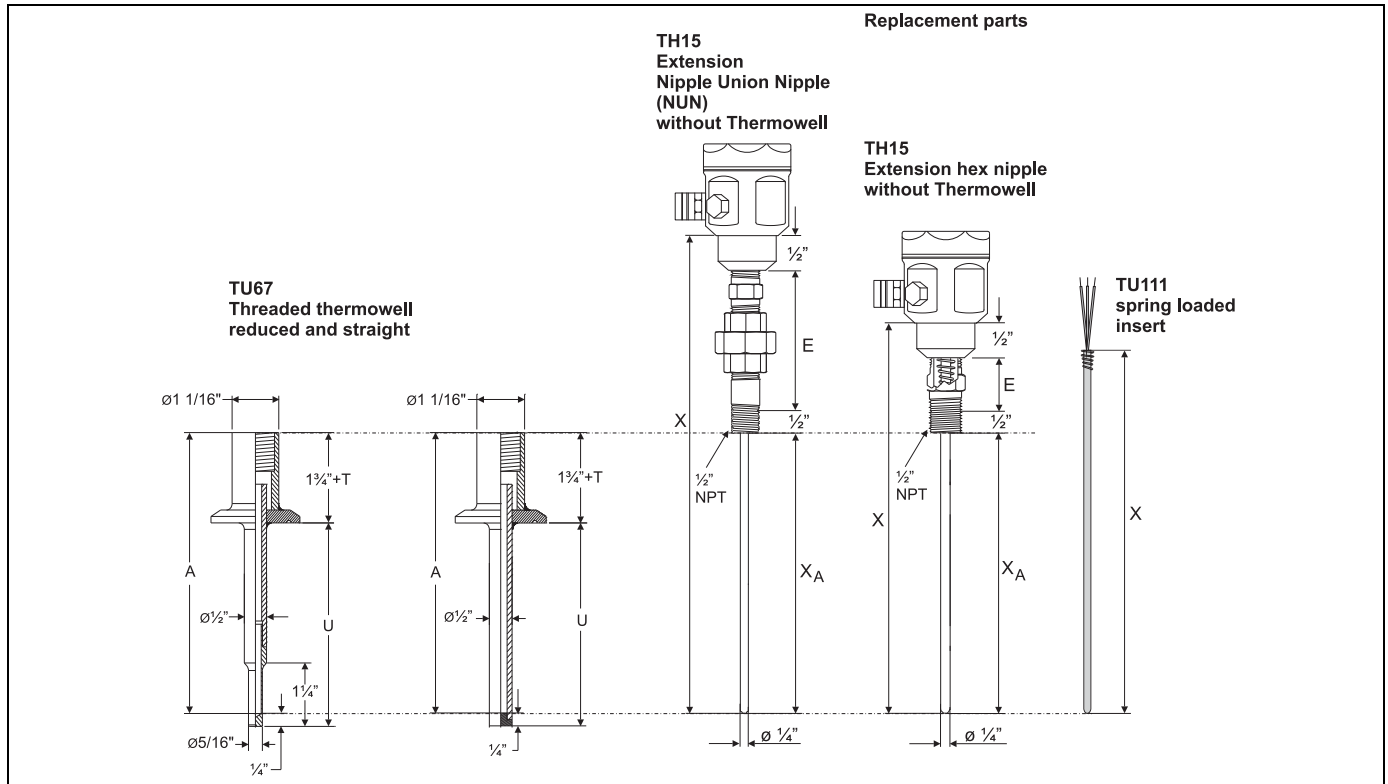

Dimensional drawing of TH27 with TH15 and spring loaded insert TU111

Pos. E: Extension

Pos. T: Lag dimension (see product structure)

Pos. U: Thermowell immersion length
 Pos. X_A, A: Immersion length RTD sensor; Thermowell drilled length
 Pos. X: Insert overall length

All thermowells are marked with:

- Material I.D.
- CRN# (Canadian Registration Number)
- Heat No.

Dimensions of TH27				
U	E	T	Process connection	Shape of Thermowell
2½", 3", 4", 4½", 5", 6", 7½", 10½" specified length in ½" increments	Hex nipple = 1" or Nipple Union Nipple (NUN) = 3"+1" or 6"+1" Material: 316SS	3"	1" + 1.5" Tri-clamp	Straight Ø½" or stepped (Ø½" reduced to Ø5/16")
			2" Tri-clamp	
			2.5" Tri-clamp	
			3" Tri-clamp	
Immersion length RTD sensor = Thermowell drilled length X _A = A = U + 1½" + T Insert overall length X = A + E				

Dimensions of TH15 (without Thermowell)	
Immersion length RTD sensor X _A	E
4", 6", 9", 12", 14" specified length 4" to 30" in ½" increments	Hex nipple = 1" or Nipple Union Nipple (NUN) = 4" or 7"

Weight From 1 to 10 lbs

Material Wetted parts 316L SS for usage up to 927 °C (1700 °F). 316L SS has good oxidation and corrosion resistance in a wide range of industrial environments with improved resistance to mild acid and pitting corrosion. Exposure to carbide precipitation, reduces corrosion resistance in the 427 to 538 °C (800 to 1000 °F) temperature range. Good mechanical properties for -184 to 788 °C (-300 to 1450 °F) temperature range. Generally regarded as standard protection tube material, other materials are available upon request.

Process connection

Tri-clamp® connection (3-A® marked)							
DN	(*)			d	D		PNmax (bar)
	A	B	C		std.	strong	
½" (***)	20,0	25,0	3,6	9,5	-	12,7	-
¾" (***)				15,8	-	19,0	-
1"	43,5	50,5	2,85	22,2	25,4	29,5	9÷20,7
1½"				34,9	-	42,6	-
2"				47,6	38,1	-	55,7
	56,5	64,0			-	50,8	-
							9÷17,2

(*) Pipes according to ISO 2037 and BS 4825 Part1.
 (***) Depends on clamping ring type, at 121°C with suitable gasket.
 (***) MicroClamp.

Surface finish

The assemblies are designed for use in food processing systems and life science industries. The wetted surfaces of the thermowell and sanitary fittings are mechanically polished to achieve a 32 µinch maximum surface

finish, in accordance with "3-A Sanitary Standards for Sensors and Sensor Fittings and Connections used on Milk and Milk Products Equipment, Number 74-03". Minimal material has been removed to achieve the indicated surface finish. Residual polishing compounds are removed after polishing operations are completed on all surfaces and sanitary end fittings. The end fitting material and sensor sheath are both composed of 316L stainless steel.

Packaging

Sanitary sensors and fittings are individually bagged and sealed to ensure cleanliness upon delivery to the final customer.

System components

Housing

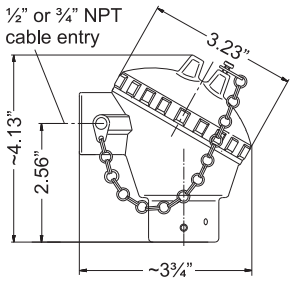
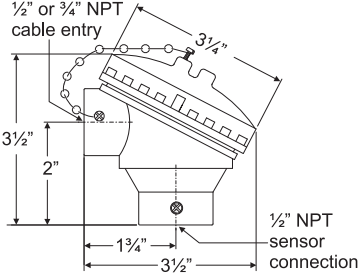
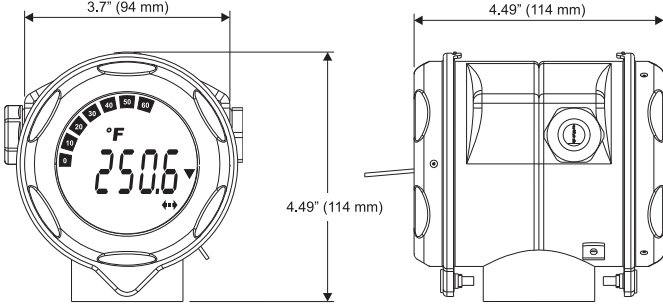
Type of housing	Specification
<p>Connection head Aluminum</p>  <p style="text-align: right; font-size: small;">T09-TH11xxxx-06-xx-xx-ae-001</p>	<ul style="list-style-type: none"> ■ Material: Die-cast Aluminum head ■ Sensor connection: 1/2" NPT Female ■ Cable entry: 1/2" NPT or 3/4" NPT Female. 1/2" NPT has a Al reducer bushing ■ Body paint: Spray SPU, RAL5012 Cover paint: Spray SPU, RAL7035 ■ Coating thread (body-cover), lubricant acc. E+H standard, MgO coating; benefits include ease of opening/closing cover and improved thread engagement. Improves lifetime of the connection head. ■ Degree of protection NEMA Type 4x Encl. (IP 66)
<p>Connection head plastic</p>  <p style="text-align: right; font-size: small;">T09-TH11xxxx-06-xx-xx-ae-000</p>	<ul style="list-style-type: none"> ■ Polypropylene, FDA compliant ■ Sensor connection: 1/2" NPT Female ■ Cable entry: 1/2" NPT or 3/4" NPT Female. 1/2" NPT with nylon reducer bushing (FDA compliant) ■ Degree of protection NEMA Type 4x Encl.
<p>Temperature field transmitter iTEMP® TMT162</p>  <p style="text-align: right; font-size: small;">T09-TMT162ZZ-06-00-xx-ae-003</p>	<ul style="list-style-type: none"> ■ Material: Stainless steel 1.4435 (AISI 316L) for hygienic applications (T17 housing) ■ Separate electronics compartment and connection compartment ■ Display rotatable in 90° increments ■ Cable entry: 2 x 1/2" NPT ■ Degree of protection NEMA Type 4x, 6P Encl. (IP66/68, 1.83 m H₂O for 24 h) ■ Brilliant blue backlit display with ease of visibility in bright sunshine or pitch darkness ■ Gold plated terminals to avoid corrosion and additional measurement errors <p>Details see Technical Information (see 'Documentation')</p>

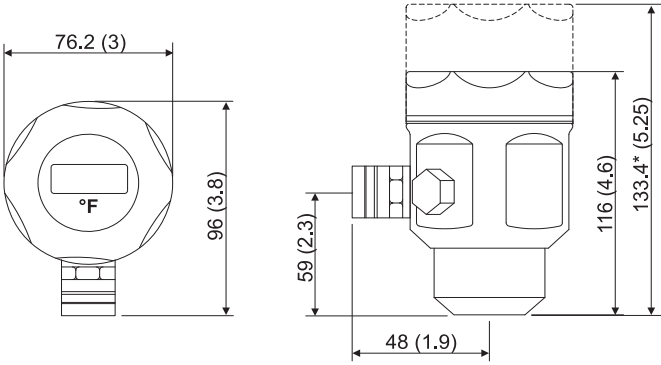
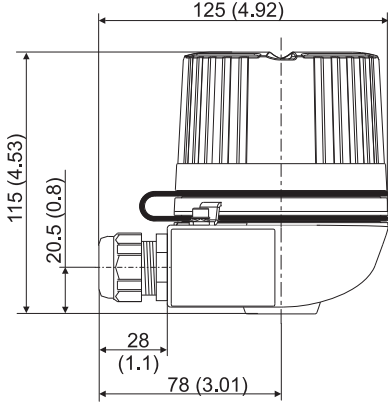
Type of housing	Specification
<p>Connection head deep drawn stainless steel, TA20J style</p>  <p>* dimensions with optional display</p> <p style="text-align: right;">a0005938</p>	<ul style="list-style-type: none"> ■ Material: Deep drawn stainless steel AISI 316L SS (hygienic design) ■ Optional with display and/or head transmitter ■ Sensor connection: ½" NPT female ■ Cable entry: ½" NPT female ■ Degree of protection NEMA Type 4x Encl. (IP 66) <p>Display:</p> <ul style="list-style-type: none"> ■ 4 digits 7-segments LC display (loop powered) ■ Maximum error: 0.1% of programmed range ■ Loop drop: 2.5 V at 22 mA ■ Max. ambient temperature: -20 to 70 °C (-4 to 160 °F) <p>The programming is executed through 3 keys mounted on the bottom of the display.</p>
<p>TA30H with display window in cover</p>  <p style="text-align: right;">a0009831</p>	<ul style="list-style-type: none"> ■ Flameproof (XP) version, explosion-protected, captive screw cap ■ Protection class: IP 66/68 ■ Max. temperature: 150 °C (300 °F) for rubber seal (observe max. permitted temperature of the cable gland!) ■ Material: aluminum; polyester powder coated ■ Cable entry glands: ½" NPT, ¾" NPT, M20x1.5, only thread G½"; plug: M12x1 PA, 7/8" FF ■ Neck tube/thermowell connection: ½" NPT ■ Color of head: blue, RAL 5012 ■ Color of cap: gray, RAL 7035 ■ Weight: 860 g (30.33 oz) ■ Head transmitter optionally available with TID10 display

Head transmitter

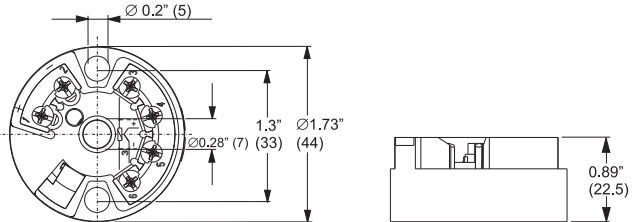
Type of transmitter	Specification
<p>iTEMP® TMT18x</p>  <p style="text-align: right;">R09-TMT182ZZ-06-06-xx-ae-001</p>	<ul style="list-style-type: none"> ■ Material <ul style="list-style-type: none"> Housing: PC Potting: PUR ■ Terminals: <ul style="list-style-type: none"> Screw terminals: 2.5 mm² (16 AWG) with latches at the fieldbus terminals for easy connection of a handheld terminal, e.g. DXR375 Spring terminals: e.g. rigid wire version 0.14 mm² to 1 mm² (24 AWG to 18 AWG); stripped length = min. 10 mm (0.39 in) ■ Degree of protection NEMA Type 4x Encl. (see also type of connection head) <p>Details see Technical Information (see 'Documentation')</p>

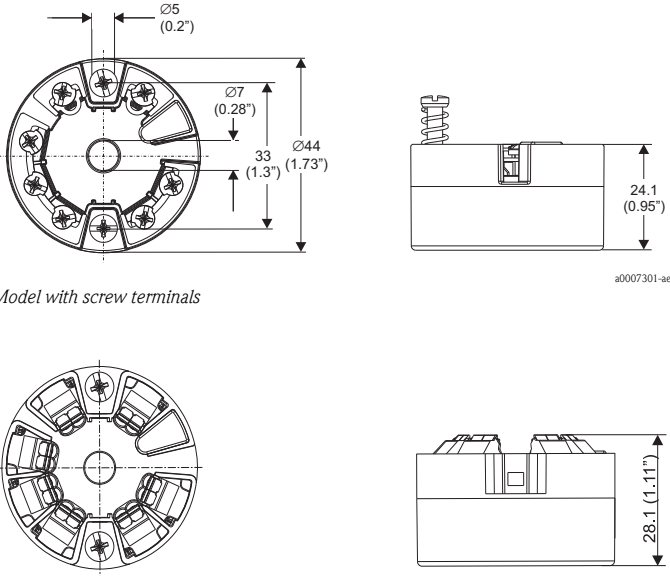
Type of transmitter	Specification
<p>iTEMP® FF TMT85 iTEMP® PA TMT84</p>  <p>Model with screw terminals</p> <p>Model with spring terminals. The same dimensions except for height of housing</p>	<ul style="list-style-type: none"> Material Housing: PC Potting: PUR Terminals: Screw terminals: 2.5 mm² (16 AWG) with latches at the fieldbus terminals for easy connection of a handheld terminal, e.g. DXR375 Spring terminals: e.g. rigid wire version 0.14 mm² to 1 mm² (24 AWG to 18 AWG); stripped length = min. 10 mm (0.39 in) Degree of protection NEMA Type 4x Encl. (see also type of connection head) <p>Details see Technical Information (see 'Documentation')</p>

Fieldbus connector

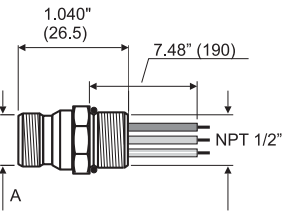
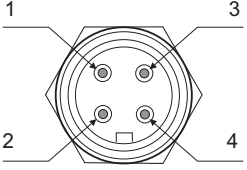
Type (dimensions in inches [mm])	Specification	
<p>Fieldbus connector to PROFIBUS® -PA or FOUNDATION Fieldbus™</p>  <p>Pos. A: M12 on PROFIBUS® -PA connector 7/8-16 UNC on FOUNDATION Fieldbus™ connector</p>	<ul style="list-style-type: none"> Ambient temperature: -40 to 150 °C (-40 to 300 °F) Degree of protection IP 67 <p>Wiring diagram:</p> 	
	<p>PROFIBUS® -PA Pos 1: grey (shield) Pos 2: brown (+) Pos 3: blue (-) Pos 4: not connected</p>	<p>FOUNDATION Fieldbus™ Pos 1: blue (-) Pos 2: brown (+) Pos 3: not connected Pos 4: ground (green/yellow)</p>

Certificates and approvals

CE Mark

The iTEMP® Series of temperature transmitters complies with the legal requirements laid out within the EU regulations.

Other standards and guidelines

- IEC 60529: Degrees of protection by housing (IP-Code).
- IEC 61010: Safety requirements for electrical measurement, control and laboratory instrumentation.
- ASTM E644:

American society for testing and materials, standard test methods for testing industrial resistance thermometers.

- NEMA - ANSI / NEMA 250
Standardization association for the electrical industry.
- IEC 60751
Industrial platinum resistance thermometer
- ASME PTC 19.3 - 1974
Performance test codes
- BPE:
Bioprocessing Equipment, ASME - BPE - 2005 Standard

3-A	A sanitary standard for Sensors, Connections and Sensor Fittings used in Milk and Milk Products Equipment, Number 74-03.
UL	Temperature transmitters are recognized components to UL 3111-1 (iTEMP® Series).
CSA GP	The installed and assembled transmitters (iTEMP® Series) are CSA GP approved.

Ordering information

Product structure, Hygienic RTD Assembly TH27

This information provides an overview of the order options available. The information is not exhaustive, however, and may not be fully up to date. More detailed information is available from your local Endress+Hauser representative.

TH27-	RTD Assembly TH27, Hygienic TW, US style		
	Process connection:		
	B	1+1½" Tri-clamp; 316L, 3-A	
	C	2" Tri-clamp; 316L, 3-A	
	D	2½" Tri-clamp; 316L, 3-A	
	E	3" Tri-clamp; 316L, 3-A	
	Y	Special version, TSP-no. to be specified	
	Thermowell immersion length U:		
	A	3"	
	B	4"	
	C	5"	
	D	6"	
	1	2½"	
	2	4½"	
	3	7½"	
	4	10½"	
	8 " (increment 0.5)	
	9	Special version, TSP-no. to be specified	
	Thermowell shape; Material:		
	1	½" straight; 316L	
	2	½" reduced 5/16"; 316L	
	9	Special version, TSP-no. to be specified	
	Thermowell Lag (T):		
	A	Not selected	
	E	3"	
	X * " (increment 0.25)	
	Y	Special version, TSP-no. to be specified	
	Extension (E):		
	1	Hex nipple SS316, E=1"	
	2	Nipple+Union+Nipple SS316, E=3"+1"	
	6	Nipple+Union+Nipple SS316, E=6"+1"	
	9	Special version, TSP-no. to be specified	

**Product structure, thermowell
TU67**

TU67-	Thermowell TU67, sanitary U. S. style									
Instrument connection:										
	B	1/2" NPT								
	9	Special version, TSP-no. to be specified								
Cap:										
	1	1"								
	2	1 1/2"								
	3	2"								
	4	2 1/2"								
	5	3"								
	9	Special version, TSP-no. to be specified								
Cap type, material:										
	A	Tri-clamp, 316L, 3-A								
	Y	Special version, TSP-no. to be specified								
Thermowell immersion length U:										
	A	3"								
	B	4"								
	C	5"								
	D	6"								
	1	2 1/2"								
	2	4 1/2"								
	3	7 1/2"								
	4	10 1/2"								
	8" (increment 0.25)								
	Y	Special version, TSP-no. to be specified								
Thermowell shape; material:										
	1	1/2" straight; 316L								
	2	1/2" reduced 5/16"; 316L								
	9	Special version, TSP-no. to be specified								
Thermowell Lag (T):										
	E	3"								
	1	not selected								
	8" (increment 0.25)								
	9	Special version, TSP-no. to be specified								
Bore diameter B:										
	1	0.260"								
	9	Special version, TSP-no. to be specified								
Accessory:										
	A	not selected								
	B	Cap, SS304								
	C	Cap + chain, SS304								
	Y	Special version, TSP-no. to be specified								
Additional test:										
	1	not selected								
	9	Special version, TSP-no. to be specified								
Certificate:										
	A	not selected								
	B	3.1 material certificate								
	Y	Special version, TSP-no. to be specified								
Documentation requirement:										
	A	not selected								
	C	Oxygen service								
	Y	Special version, TSP-no. to be specified								
Version:										
	K	Standard								
	M	Pharma surface 15RA								
	Y	Special version, TSP-no. to be specified								
TU67-										← Order code (complete)

Documentation

- Compact instructions TH27 RTD temperature assembly for food, dairy & pharmaceutical applications (KA263r/24/ae)

Technical information:

- Replacement insert RTD TH15 (TI110R/24/ae)
- Field transmitter iTEMP® TMT162 (TI086r/24/ae)
- Temperature head transmitter iTEMP® Pt TMT180 (TI088r/24/ae)
- Temperature head transmitter iTEMP® PCP TMT181 (TI070r/24/ae)
- Temperature head transmitter iTEMP® HART® TMT182 (TI078r/24/ae)
- Temperature head transmitter iTEMP® PA® TMT84 (TI138r/24/ae)
- Temperature head transmitter iTEMP® TMT85 FF (TI134r/24/ae)

Application example:

- Technical information Safety Data Manager Memograph M (TI113r/09/en)
- Technical information Field indicator RIA16 (TI00144R/09/en)

USA	Canada	México	Instruments International
Endress+Hauser, Inc. 2350 Endress Place Greenwood, IN 46143 USA Tel.317-535-7138 Fax317-535-8498 Sales888-ENDRESS Service800-642-8737 inquiry@us.endress.com www.us.endress.com	Endress+Hauser Canada 1075 Sutton Drive Burlington, ON L7L 5Z8 Canada Tel.905-681-9292 800-668-3199 Fax905-681-9444 www.ca.endress.com	Endress+Hauser, México, S.A. de C.V.F Fernando Montes de Oca 21 Edificio A Piso 3 Fracc. Industrial San Nicolas 54030. Tlalnepantla de Baz Estado de México México Tel.+52 55 5321 2080 Fax+52 55 5321 2099 eh.mexico@mx.endress.com www.mx.endress.com	Endress+Hauser Instruments International AG Kaegenstrasse 2 4153 Reinach Switzerland Tel.+41 61 715 81 00 Fax+41 61 715 25 00 www.endress.com info@ii.endress.com

Endress + Hauser 

People for Process Automation