

Technical Information

TLR1 RTD measuring sensor

Assembly with threaded process connection and terminal head



Fixed insert, adjustable or fixed fitting

Application

The assembly is designed for use in most general applications. The thermometer comprises of various diameter fixed inserts with either a transmitter mounting plate or a ceramic terminal block. The terminal head can be selected from a wide choice of standard items.

To be installed into a thermowell or directly into the process by means of an adjustable or fixed fitting. They can also be used in all applications where small immersion lengths are needed. Special attention should be given to the maximum operating temperatures of the terminal heads.

Your benefits

- Pt100 measuring element according to IEC 60751 with an accuracy Class A according to IEC 60751 and Band 5 (1/10 DIN)
- Sheath material SS316/L
- Customized immersion length
- Electrical connection by means of a ceramic terminal block or head mounted transmitter with universal inputs, galvanically isolated and various output signals:
 - Analog output 4...20 mA
 - HART®
 - PROFIBUS® PA
 - FOUNDATION Fieldbus™

Performance characteristics

Measuring range

Input	Max. measuring range limits
Pt100 (RTD) as per IEC 60751	-200 to +600 °C (-328 to +1112 °F)

Accuracy

RTD corresponding to IEC 60751

Class	max. Tolerances (°C)	Temperature range
RTD max. error type TF - range: -50 to +400 °C		
Cl. A	$\pm(0.15 + 0.002 \cdot t ^{1})$	-50 °C to +250 °C
Band 5	$\pm 0.01\%$ of R ₀ (R ₀ = resistance at 0 °C)	-50 °C to +200 °C
RTD max. error type WW - range: -200 to +600 °C		
Cl. A	$\pm(0.15 + 0.002 \cdot t ^{1})$	-200 °C to +600 °C
Band 5	$\pm 0.01\%$ of R ₀ (R ₀ = resistance at 0 °C)	-50 °C to +200 °C

1) |t| = absolute value °C



For measurement errors in °F, calculate using equations above in °C, then multiply the outcome by 1.8.

Operating conditions

Ambient temperature

Terminal head	Temperature in °C (°F)
Without mounted head transmitter	Depends on the terminal head and the cable glands used
With mounted head transmitter	-40 to 85 °C (-40 to 185 °F)

Design, dimensions

Immersion length L in mm	Sheath diameter ØD in mm	Sheath Material	Process connection	
100, 150, 200, 250, 300 or free selectable	3, 4.5, 6	SS316/L	Fixed thread: ¼" NPT, ½" NPT, G½" (BSPP) Material: SS316	Compression fitting: ¼" NPT, ½" NPT, G½" (BSPP) Material: SS316 or brass

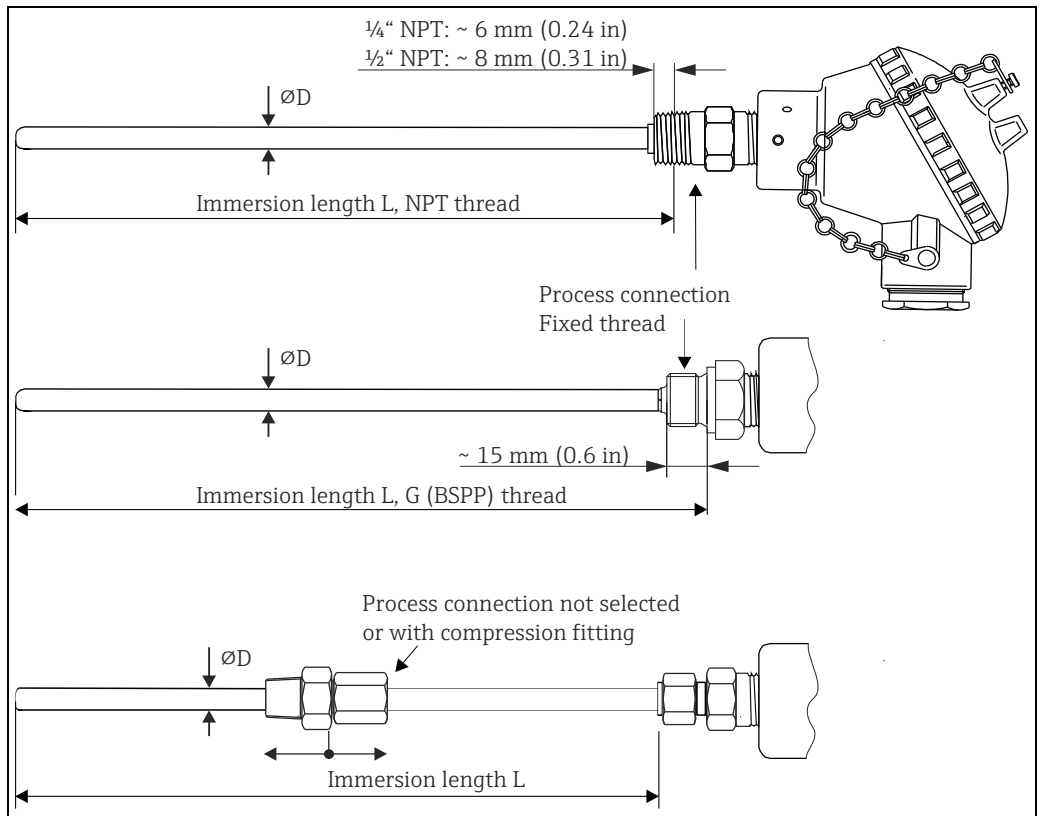

Design of the thermometer

A0013914

Components

Family of temperature transmitters

Thermometers fitted with iTEMP transmitters are an installation-ready complete solution to improve temperature measurement by significantly increasing accuracy and reliability, when compared to direct wired sensors, as well as reducing both wiring and maintenance costs.

PC programmable head transmitters

They offer a high degree of flexibility, thereby supporting universal application with low inventory storage. The iTEMP transmitters can be configured quickly and easily at a PC. Endress+Hauser offers free configuration software which can be downloaded from the Endress+Hauser Website. More information can be found in the Technical Information. → [11](#)

HART® programmable head transmitters

The transmitter is a 2-wire device with one or two measuring inputs and one analog output. The device not only transfers converted signals from resistance thermometers and thermocouples, it also transfers resistance and voltage signals using HART® communication. It can be installed as an intrinsically safe apparatus in Zone 1 hazardous areas and is used for instrumentation in the terminal head (flat face) as per DIN EN 50446. Swift and easy operation, visualization and maintenance by PC using operating software, Simatic PDM or AMS. For more information, see the Technical Information. → [11](#)

PROFIBUS® PA head transmitters

Universally programmable head transmitter with PROFIBUS® PA communication. Conversion of various input signals into digital output signals. High accuracy over the complete ambient temperature range. Swift and easy operation, visualization and maintenance using a PC directly from the control panel, e. g. using operating software, Simatic PDM or AMS. For more information, see the Technical Information. → [11](#)

FOUNDATION Fieldbus™ head transmitters

Universally programmable head transmitter with FOUNDATION Fieldbus™ communication. Conversion of various input signals into digital output signals. High accuracy over the complete ambient temperature range. Swift and easy operation, visualization and maintenance using a PC directly from the control panel, e.g. using operating software such as ControlCare from Endress+Hauser or NI Configurator from National Instruments. For more information, see the Technical Information. → [11](#)

Advantages of the iTEMP transmitters:

- Dual or single sensor input (optionally for certain transmitters)
- Unsurpassed reliability, accuracy and long-term stability in critical processes
- Mathematical functions
- Monitoring of the thermometer drift, sensor backup functionality, sensor diagnostic functions
- Sensor-transmitter matching for dual sensor input transmitter, based on Callendar/Van Dusen coefficients
- Screw terminals or spring terminals for flexible wires with wire-end ferrules with plastic ferrule, selectable for PROFIBUS® PA, FOUNDATION Fieldbus™ and HART® programmable transmitters with dual sensor input:
 - Screw terminals (cable up to max. 2.5 mm² / 16 AWG)
 - Spring terminals (e. g. from 0.25 mm² to 0.75 mm² / 24 AWG to 18 AWG)

Display

Pluggable display as option	
	<ul style="list-style-type: none"> ■ Displays the actual measured value and the measurement point identification ■ Displays fault events in inverse color with channel ident and diagnostics code ■ DIP-switches on the rear for hardware set-up, e. g. PROFIBUS® PA bus address <p>i Display is only available with suitable terminal head with display window, e.g. TA30.</p>
a0009820	

Terminal heads

All dimensions in mm (in). Specifications without head transmitter installed. For ambient temperatures with head transmitter installed, see 'Operating conditions' section. → [2](#)

KH (aluminum)	Specification
	<ul style="list-style-type: none"> ■ Protection class: IP 68 ■ Max. temperature: -50 to +150 °C (-58 to +302 °F) without cable gland ■ Material: aluminum ■ Cable entry incl. glands: M20x1.5 ■ Color of head: silver ■ Weight: approx. 300 g (10.6 oz)
a0023512	

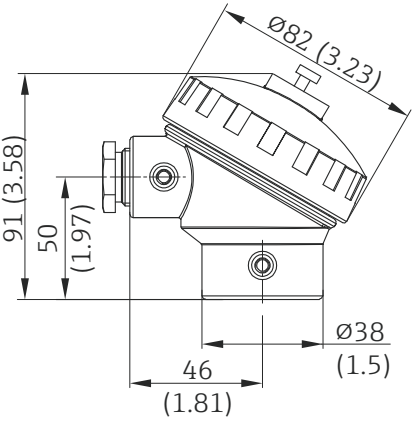
KH (PVC)	Specification
	<ul style="list-style-type: none"> ▪ Protection class: IP 65 ▪ Max. temperature: -40 to +120 °C (-40 to +248 °F) without cable gland ▪ Material: PVC ▪ Cable entry incl. glands: M20x1.5 ▪ Color of head: black ▪ Weight: approx. 200 g (7.05 oz)

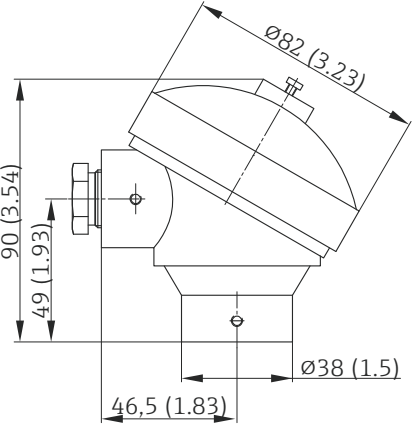
KH (stainless steel)	Specification
	<ul style="list-style-type: none"> ▪ Protection class: IP 68 ▪ Max. temperature: -50 to +150 °C (-58 to +302 °F) without cable gland ▪ Material: stainless steel ▪ Cable entry incl. glands: M20x1.5 ▪ Color of head: natural ▪ Weight: approx. 900 g (31.75 oz)

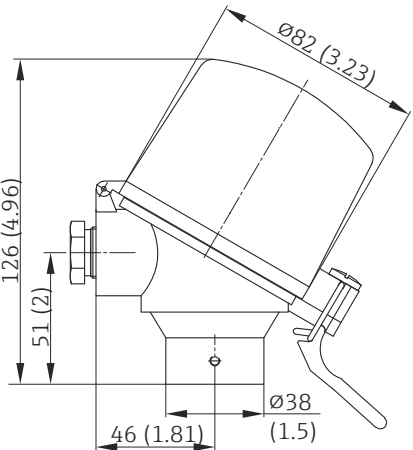
KH (aluminum, high cover)	Specification
	<ul style="list-style-type: none"> ▪ Protection class: IP 68 ▪ Max. temperature: -50 to +150 °C (-58 to +302 °F) without cable gland ▪ Material: aluminum ▪ Cable entry incl. glands: M20x1.5 ▪ Color of head: silver ▪ Weight: approx. 350 g (12.35 oz)

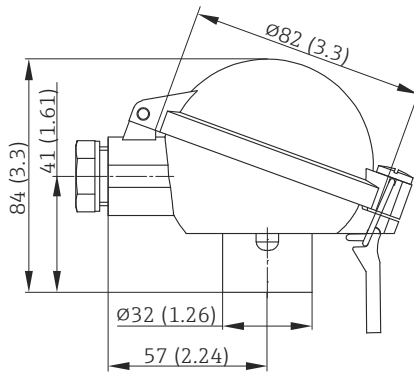
BUZ	Specification
 <p>Technical drawing of BUZ buzzer showing dimensions: Ø82 (3.3), 84 (3.3), 41 (1.61), Ø32 (1.26), 57 (2.24). Part number a0023518.</p>	<ul style="list-style-type: none"> ■ Protection class: IP 66 ■ Max. temperature: -50 to +150 °C (-58 to +302 °F) without cable gland ■ Material: aluminum ■ Cable entry incl. glands: M20x1.5 ■ Color of head: silver ■ Weight: approx. 300 g (10.6 oz)

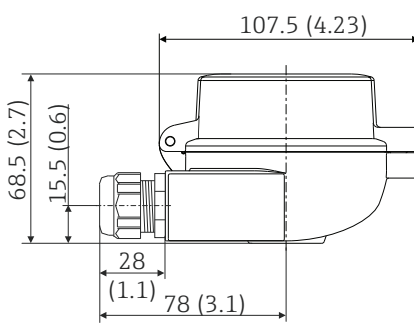
TA30A	Specification
 <p>Technical drawing of TA30A showing dimensions: 107.5 (4.23), 68.5 (2.7), 15.5 (0.6), 28 (1.1), 78 (3.1). Part number a0009820.</p>	<ul style="list-style-type: none"> ■ Protection class: IP66/68 (NEMA Type 4x incl.) ■ Max. temperature: -50...150 °C (-58 to +302 °F) without cable gland ■ Material: aluminum, polyester powder coated ■ Seals: silicone ■ Cable entry incl. glands: ½" NPT and M20x1.5 ■ Head color: blue RAL 5012 ■ Cap color: grey RAL 7035 ■ Weight: 330 g (11.64 oz) ■ Ground terminal, internal and external

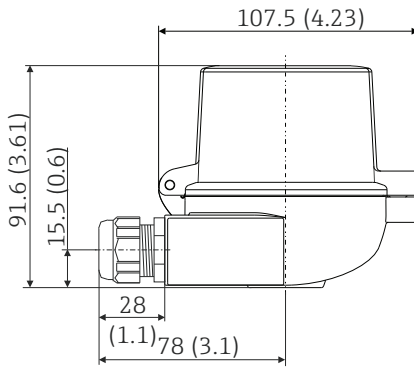
TA30A with display window	Specification
 <p>Technical drawing of TA30A with display window showing dimensions: 107.5 (4.23), 91.6 (3.61), 15.5 (0.6), 28 (1.1), 78 (3.1). Part number a0009821.</p>	<ul style="list-style-type: none"> ■ Protection class: IP66/68 (NEMA Type 4x incl.) ■ Max. temperature: -50...150 °C (-58 to +302 °F) without cable gland ■ Material: aluminum, polyester powder coated ■ Seals: silicone ■ Cable entry incl. glands: M20x1.5 ■ Head color: blue RAL 5012 ■ Cap color: grey RAL 7035 ■ Weight: 420 g (14.81 oz) ■ With TID10 display ■ Ground terminal, internal and external

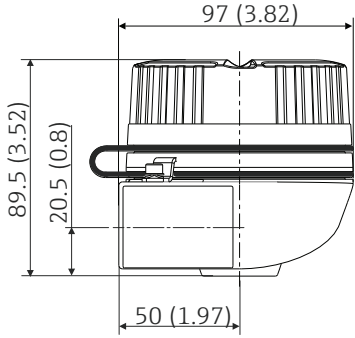
TA30H	Specification
 <p style="text-align: right; font-size: small;">a0023415</p>	<ul style="list-style-type: none"> ▪ Flameproof (XP) version, explosion-protected, captive screw cap ▪ Protection class: IP 66/68 ▪ Max. temperature: -50 to +150 °C (-58 to +302 °F) for rubber seal without cable gland ▪ Material: aluminum; polyester powder coated ▪ Thread: M20x1.5 ▪ Color of head: blue, RAL 5012 ▪ Color of cap: gray, RAL 7035 ▪ Weight: approx. 640 g (22.6 oz) ▪ Ground terminal, internal and external

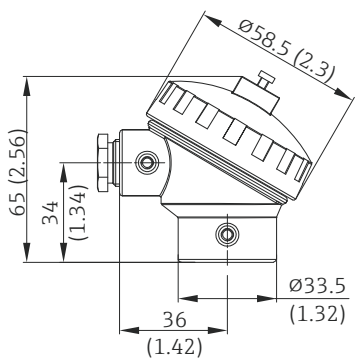
KS (Aluminum)	Specification
 <p style="text-align: right; font-size: small;">a0021513</p>	<ul style="list-style-type: none"> ▪ Protection class: IP 67 ▪ Max. temperature: -50 to +150 °C (-58 to +302 °F) without cable gland ▪ Material: aluminum ▪ Cable entry incl. glands: M16x1.5 ▪ Color of head: silver ▪ Weight: approx. 150 g (5.3 oz)

Installation conditions

Orientation No restrictions.

Installation instructions

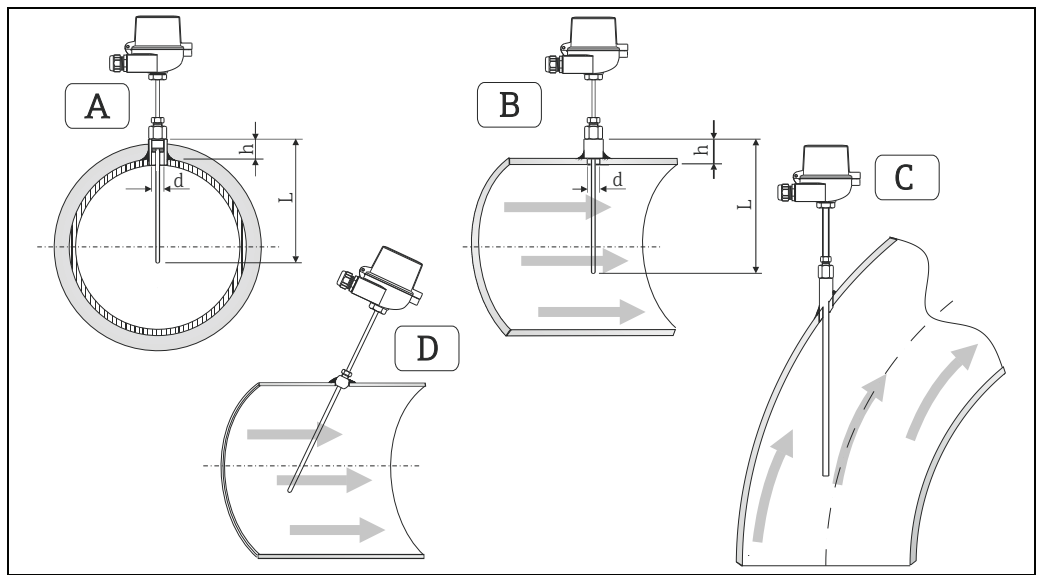

Installation examples

A - B: In pipes with a small cross section the sensor tip should reach or extend slightly past the center line of the pipe (= L)
 C - D: Tilted installation

The immersion length of the thermometer influences the accuracy. If the immersion length is too small then errors in the measurement are caused by heat conduction via the process connection and the container wall. If installing into a pipe then the immersion length should be half of the pipe diameter, if possible (see A and B). A further solution could be an angled (tilted) installation (see C and D). When determining the immersion length all thermometer parameters and the process to be measured must be taken into account (e.g. flow velocity, process pressure).

- Installation possibilities: Pipes, tanks or other plant components
- Recommended minimum immersion length = 80 to 100 mm (3.15 to 3.94 in)

The immersion length should correspond to at least 8 times of the thermowell diameter.

Example: Thermowell diameter 12 mm (0.47 in) x 8 = 96 mm (3.8 in). A standard immersion length of 120 mm (4.72 in) is recommended.

Wiring diagrams

Type of sensor connection

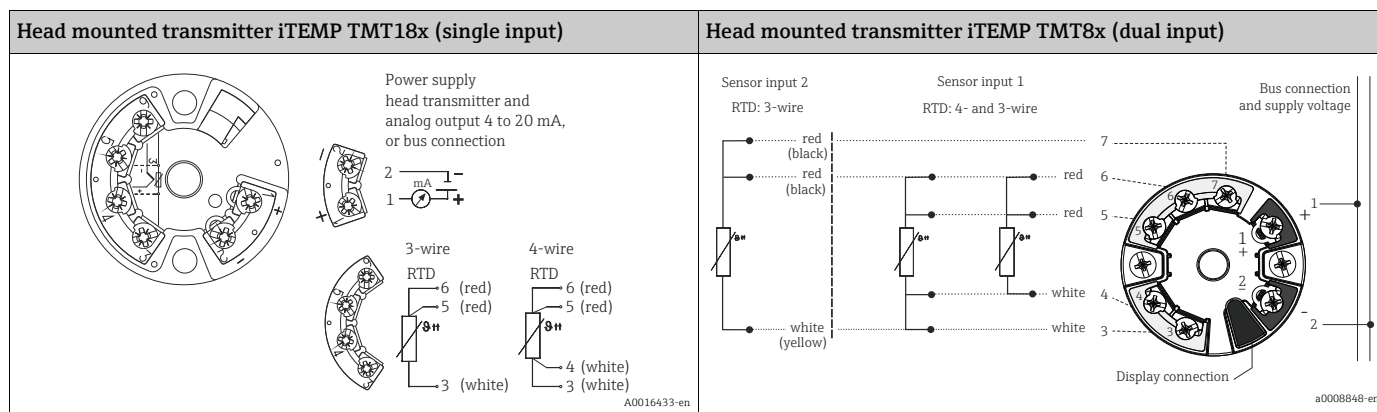

Terminal block mounted

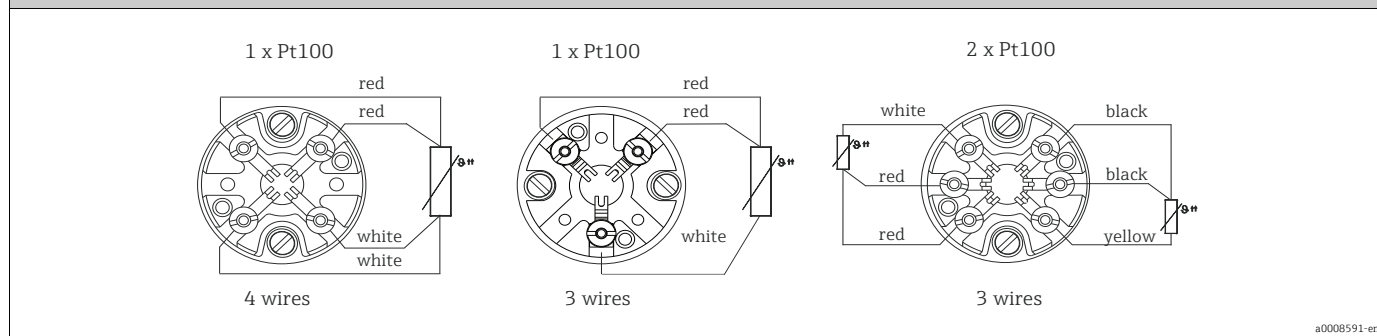

Certificates and approvals

Material certification

The material certificate 3.1 (according to EN 10204) can be selected separately in the product configuration.

Test report and calibration

The "Factory calibration" is carried out according to an internal procedure in a laboratory of Endress+Hauser accredited by SANAS (South African National Accreditation System). All temperature calibrations, upon selection in the product configuration, are done according to the following standards: IEC 751, 2; IEC 60751, ASTM E220, ASTM E644 and ITS90.

In the case of thermometers without a replaceable insert, the entire thermometer - from the process connection to the tip of the thermometer - is calibrated.

PER (Pressure Equipment Regulation)

The assembly has no pressurised volumes and thus is not subject to the conformity assessment requirements of the Pressure Equipment Regulation when operating within the published product specifications.

Reasons: The definitions of pressure-bearing equipment as per sections 4.1.1 and 4.3.2 of the directive SANS 347:2012 determine that:







- The products are classified as pressure accessories and are designed and manufactured in accordance with sound engineering practice (SEP) in order to ensure safe use.
- This declaration does not apply if the product is used as a critical component in a safety system. In this case, the product must be assessed in line with the same category or higher than the equipment they protect (section 4.3.3).

Accessories

Various accessories, which can be ordered with the device or subsequently from Endress+Hauser, are available for the device. Detailed information on the order code in question is available from your local Endress+Hauser sales center or on the product page of the Endress+Hauser website:

www.endress.com.



Communication-specific accessories

Accessories	Description
Configuration kit TXU10	Configuration kit for PC-programmable transmitter with setup software and interface cable for PC with USB port. Order code: TXU10-xx
Commubox FXA195 HART	For intrinsically safe HART communication with FieldCare via the USB interface.  For details, see Technical Information TI00404F
Commubox FXA291	Connects Endress+Hauser field devices with a CDI interface (= Endress+Hauser Common Data Interface) and the USB port of a computer or laptop.  For details, see Technical Information TI00405C
HART Loop Converter HMX50	Is used to evaluate and convert dynamic HART process variables to analog current signals or limit values.  For details, see Technical Information TI00429F and Operating Instructions BA00371F
Wireless HART adapter SWA70	Is used for the wireless connection of field devices. The Wireless HART adapter can be easily integrated into field devices and existing infrastructures, offers data protection and transmission safety and can be operated in parallel with other wireless networks with minimum cabling complexity.  For details, see Operating Instructions BA061S
Fieldgate FXA320	Gateway for the remote monitoring of connected 4...20 mA measuring devices via a Web browser.  For details, see Technical Information TI00025S and Operating Instructions BA00053S
Fieldgate FXA520	Gateway for the remote diagnostics and remote configuration of connected HART measuring devices via a Web browser.  For details, see Technical Information TI00025S and Operating Instructions BA00051S
Field Xpert SFX100	Compact, flexible and robust industry handheld terminal for remote configuration and for obtaining measured values via the HART current output (4...20 mA).  For details, see Operating Instructions BA00060S

Service-specific accessories

Accessories	Description
Applicator	<p>Software for selecting and sizing Endress+Hauser measuring devices:</p> <ul style="list-style-type: none"> Calculation of all the necessary data for identifying the optimum measuring device: e.g. pressure loss, accuracy or process connections Graphic illustration of the calculation results <p>Administration, documentation and access to all project-related data and parameters over the entire life cycle of a project.</p> <p>Applicator is available:</p> <ul style="list-style-type: none"> Via the Internet: https://wapps.endress.com/applicator On CD-ROM for local PC installation.
Konfigurator ^{+temperature}	<p>Software for selecting and configuring the product depending on the measuring task, supported by graphics. Includes a comprehensive knowledge database and calculation tools:</p> <ul style="list-style-type: none"> For temperature competence Quick and easy design and sizing of temperature measuring points Ideal measuring point design and sizing to suit the processes and needs of a wide range of industries <p>The Konfigurator is available: On request from your Endress+Hauser sales office on a CD-ROM for local PC installation.</p>
W@M	<p>Life cycle management for your plant</p> <p>W@M supports you with a wide range of software applications over the entire process: from planning and procurement, to the installation, commissioning and operation of the measuring devices. All the relevant device information, such as the device status, spare parts and device-specific documentation, is available for every device over the entire life cycle.</p> <p>The application already contains the data of your Endress+Hauser device. Endress+Hauser also takes care of maintaining and updating the data records.</p> <p>W@M is available:</p> <ul style="list-style-type: none"> Via the Internet: www.endress.com/lifecyclemanagement On CD-ROM for local PC installation.
FieldCare	<p>FDT-based plant asset management tool from Endress+Hauser. It can configure all smart field units in your system and helps you manage them. By using the status information, it is also a simple but effective way of checking their status and condition.</p> <p> For details see operating instructions BA00027S and BA00059S</p>

System components

Accessories	Description
Field display unit RIA16	<p>The display unit records the analog measuring signal from the head transmitter and shows this on the display. The LC display shows the current measured value in digital form and as a bar graph indicating a limit value violation. The display unit is looped into the 4...20 mA circuit and gets the required energy from there</p> <p> For details: Technical Information TI144R/09</p>
RN221N	<p>Active barrier with power supply for safe separation of 4...20 mA standard signal circuits. Offers bidirectional HART transmission.</p> <p> For details: Technical Information TI073R/09</p>
RNS221	<p>Supply unit for powering two 2-wire measuring devices solely in the non-Ex area. Bidirectional communication is possible via the HART communication jacks.</p> <p> For details: Technical Information TI00081R/09</p>

Ordering information

Detailed ordering information is available from the following sources:

- In the Product Configurator on the Endress+Hauser website:
www.endress.com → Select country → Products → Select device → Device support: Configure your selected product
- From your Endress+Hauser Sales Center:
www.endress.com/worldwide



Product Configurator - the tool for individual product configuration

- Up-to-the-minute configuration data
- Depending on the device: Direct input of information specific to measuring point, such as measuring range or operating language
- Automatic verification of exclusion criteria
- Automatic creation of the order code and its breakdown in PDF or Excel output format
- Ability to order directly in the Endress+Hauser Online Shop

Documentation

Technical Information iTEMP Temperature head transmitter:

- TMT181, PC programmable, single input, RTD, TC, Ω , mV (TI00070R/09/en)
- TMT182 HART[®], single input, RTD, TC, Ω , mV (TI078R/09/en)
- TMT82 HART[®], dual input, RTD, TC, Ω , mV (TI01010T/09/en)
- TMT84 PROFIBUS[®] PA, dual input, RTD, TC, Ω , mV (TI00138R/09/en)
- TMT85 FOUNDATION Fieldbus[™], dual input, RTD, TC, Ω , mV (TI00134R/09/en)

www.addresses.endress.com
