

Technical Information / Operating Instructions Source Container FQG61/62

Radiometric Measurement



Container with source holder for manual or pneumatic switch-ON/switch-OFF

Application

The FQG61 and FQG62 source containers are designed to hold the radioactive source during radiometric level limit measurement, level measurement and density measurement. The radiation is emitted almost unattenuated in one direction only, and is damped in all other directions. FQG61 and FQG62 differ from each other in terms of size and screening effect.

Your benefits

- Lightweight device provides best possible screening thanks to almost spherical design
- Safe and easy source replacement
- Highest safety classification for the source supplied (DIN 25426/ISO 2919, typical classification C66646)
- Compact device that is easy to mount
- Various angles of emission for optimum adaptation to the application
- Manual or pneumatic switch-ON/switch-OFF
- Padlock, cylinder lock or locking bolt for fixing the switching position
- Switch status easily identified
- Fire-resistant version +821 °C (+1510 °F) / 30 minutes

Table of contents

Safety Instructions	3	Operation	31
Designated use	3	FQG61/FQG62; Feature 020, Option model A	31
Basic Instructions for use and storage	3	FQG61/FQG62; Feature 020, Option model B	32
Hazardous area	3	FQG61/FQG62; Feature 020, Option model C	33
General instructions on radiation protection	4	FQG61/FQG62; Feature 020, Option model D	34
Legal requirements for radiation protection	4		
Supplementary Instructions	5	Maintenance and Inspection	35
Symbols	5	Cleaning	35
		Maintenance and Inspection	35
Function and system design	6	Routine test of the shutter mechanism	36
Function	6	Routine leak test procedure	37
Attenuation factor and half-value layers	6		
Maximum activity of the radiation source	6	Emergency procedure	38
Dose rate diagrams	7	Objective and overview	38
		Notification to authority	38
Mechanical construction	9		
Version	9	Procedures after termination of the application ...	39
Design, Dimensions	9	Internal measures	39
Radiation emission channel	12	Return	39
Weight	13		
Materials	13	Ordering information	40
Safety equipment	18	Ordering information	40
Pneumatic actuator	18	Scope of delivery	40
		Delivery	40
Ambient conditions	18		
Ambient temperature	18	Accessories	41
Ambient pressure	18	Clamping device FHG61	41
Vibration resistance	18	Measuring path FHG62	42
Fire	18		
Degree of protection	18	Associated documentation	43
		Gamma Radiation Source FSG60/FSG61	43
Identification	19	Source container FQG60, FQG61, FQG62, FQG63	43
Nameplates	19	Clamping Device FHG61	43
		Measuring Path FHG62	43
Installation	22	Gamma Modulator FHG65, Synchronizer FHG66	43
Incoming acceptance	22	Radiation Source Container QG2000	43
Transport	22	Gammapilot M FMG60	43
Mounting hints	22	Gammapilot FTG20	43
Mounting position for level measurement	23	Supplementary Instruction Manuals	44
Mounting position for level limit detection	24	Manufacturer Declaration Radiation Source Container	45
Mounting position for density measurement	24		
Orientation of the fireproof version	25		
Mounting device (supplied by customer)	26		
Toothed lock washers	26		
Torque for the mounting screws	26		
Post-installation check	27		
Connection of the pneumatic actuator	28		
Compressed-air connection	28		
Connection of the proximity switches	29		
Commissioning	30		
Reading the switch status	30		
Technical data of the pneumatic actuator	30		

Safety Instructions

Designated use

The FQG61 and FQG62 source containers described in this document contain the radioactive source, which is used for radiometric measurement of level, interface and density. It screens the radiation towards the surrounding and allows it to be emitted almost unattenuated only in the direction of the measurement.

In order to guarantee the screening effect and to exclude damage of the radiation source, all instructions given in this Technical Information for mounting and operation as well as all regulations for radioactive protection are to be followed exactly.

Endress+Hauser accepts no responsibility for any damage caused by incorrect use.

Basic Instructions for use and storage

- Observe the applying rules and national regulations.
- Observe the radiation protection regulations in use, storage and for work on the radiometric measuring system.
- Observe warning signs and safety areas.
- Install and operate the device according to this manual and the relevant conditions as specified by the regulatory authority.
- The device shall not be operated or stored outside the specified parameters.
- Protect the device against extreme influences (i.e. chemical products, weather, mechanical impacts, vibrations) when operated or stored.
- Always secure the OFF position of the source insert using the padlock.
- Before switching ON the radiation beam it is necessary to ensure that no personnel are within the area of the radiation (or, indeed, inside the vessel). The radiation beam may only be switched ON by specially trained personnel.
- Do not operate or store damaged or corroded devices. Contact the responsible radiation safety officer for appropriate instructions and measures when damage or corrosion occurs.
- Conduct the required leak testing procedure according to the applying regulations and instructions.

⚠ WARNING

If the instrument is exposed to strong vibrations or mechanical impacts, the safety pin can become abraded. This may lead to a loss of the source insert. Stability and tightness of the source insert must be checked in periodical intervals.

⚠ CAUTION

In case of doubt about proper condition of the device check the area around the device for leakage radiation and/or contact immediately the responsible radiation safety officer.

Hazardous area

General Instructions

⚠ CAUTION

The suitability of the radiometric measurement method and of the device for applications in hazardous areas has to be checked by the operator of the plant according to national regulations.

The following has to be observed:

- Avoid electrostatic charge at the device. Do not rub dry.
- The device must be integrated in the potential equalization of the plant. In order to ensure electrical contact between the radiation source container and the mounting support, the supplied toothed lock washers have to be used (→  26).

Additional instructions for pneumatically operated radiation source containers

⚠ CAUTION

For applications in hazardous area of the category ATEX II 2 G the associated Safety Instructions (XA) have to be observed. The pneumatic actuator may not be operated in locations where the ambient conditions may lead to corrosion in or at the pneumatic actuator.

General instructions on radiation protection

When working with radioactive sources, any unnecessary exposure to radiation must be avoided. Unavoidable exposure to radiation must be kept to as low a level as possible. Three important measures help you to achieve this:

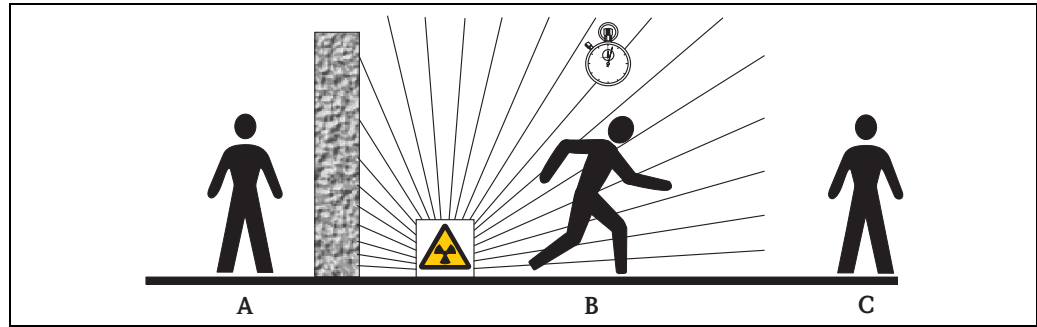

A Screening
B Time
C Distance

Screening

Ensure the screening between the radiation source and you and all other persons is as good as possible. Source containers (e.g. FQG60, FQG61/FQG62, FQG63, QG2000) and all high-density materials (lead, iron, concrete etc.), can be used for effective screening purposes.

Time

Time spent in the exposed area should be kept to a minimum.

Distance

Keep at as large a distance as possible from the radiation source. The local dose rate of the radiation decreases with the square of the distance from the radiation source.

Legal requirements for radiation protection

Handling radioactive sources is legally controlled. The radiation protection regulations of the country in which the plant is to be operated are to be strictly observed. For example, the valid radiation protection requirements are applicable in Germany. The following important points derived from this for radioactive measurement are:

Handling permit

A handling permit is required for operating a plant which uses gamma radiation. Application for the permit must be made to the Land government or the authority responsible (Land Offices for Environmental Protection, Trade Inspection Offices, etc.). The Endress+Hauser Sales Organization will be pleased to help you to obtain the permit.

Radiation Safety Officer

The operator of the plant must nominate someone responsible for radiation protection who has the necessary specialist knowledge and who is responsible for observing all radiation protection regulations and procedures for radiation protection. Endress+Hauser offers training courses in which the necessary specialist knowledge can be acquired.

Control area

Only persons exposed to radiation during the course of their job may sojourn in control areas (i.e. areas where the local dose rate exceeds a specific value) provided they are subjected to official personnel dose monitoring procedures. For the Federal Republic of Germany the limit values for the control area are specified in the current radiation protection requirements. The Endress+Hauser sales office will be pleased to provide further information of radiation protection and regulations in other countries.

Supplementary Instructions





Observe the associated Instruction Manuals:

- SD00292F/00/EN (for Canada)
- SD00293F/00/EN (for the USA)



NOTICE

This document represents in combination with the nameplates the documentation for "hochradioaktive Strahlenquellen" according to StSchV §69 (2) in Germany.

Symbols**Safety symbols**

Symbol	Meaning
 A0011189-DE	Danger! This symbol alerts you to a dangerous situation. Failure to avoid this situation will result in serious or fatal injury.
 A0011190-DE	WARNING! This symbol alerts you to a dangerous situation. Failure to avoid this situation can result in serious or fatal injury.
 A0011191-DE	CAUTION! This symbol alerts you to a dangerous situation. Failure to avoid this situation can result in minor or medium injury.
 A0011192-DE	NOTICE! This symbol contains information on procedures and other facts which do not result in personal injury.

Symbols for certain types of information

Symbol	Meaning
 A0011193	Tip Indicates additional information.
 A0015484	Reference to page Refers to the corresponding page number.
1. , 2. , ...	Series of steps

Symbols in graphics

Symbol	Meaning
1, 2, 3, 4, ...	Item numbers
1. , 2. , ...	Series of steps
A, B, C, D, ...	Views

Function and system design

Function

Function of the radiation source container

In the FQG61/FQG62 source container, the radioactive source is surrounded by a steel casing filled with lead which screens off gamma radiation. The radiation is emitted, almost unattenuated, in one direction only through a channel (focussing emission channel). This beam is used for the radiometric measurement.

Switching the radiation on and off

- By turning the insert 180°, the radiation source is positioned in the radiation emission channel (radiation is switched on) and removed from the channel (radiation is switched off).
- The current switching position (ON or OFF) is clearly indicated on the exterior of the radiation source container.
- The OFF position can be secured by a cylinder lock or padlock (depending on the version; see product structure: feature 020, "Version").
- The ON position can be secured by a cylinder lock, a padlock or a locking bolt (depending on the version; see product structure: feature 020, "Version").

Remote control/remote indication of the switching state

Versions with pneumatic actuator are available, which enables to remotely switch the radiation on and off (product structure: feature 020, "Version"). These versions have proximity switches for remote indication of the switching state (ON or OFF).

Fire-resistant version

A fire-resistant version of the radiation source containers is available (product structure: feature 670, "Additional Function"). This version has a compensation compartment, which is welded laterally onto the housing. In case of fire the liquefied lead will be collected in the compensation compartment thus ensuring the increased fire-resistance.

Attenuation factor and half-value layers

	FQG61		FQG62	
	⁶⁰ Co	¹³⁷ Cs	⁶⁰ Co	¹³⁷ Cs
Attenuation factor F_s	37	294	181	3100
Number of half-value layers	5.2	8.2	7.5	11.6

NOTICE

The table contains typical values, which do not take into account production-dependent fluctuations of the source activity and tolerances of the measuring devices.

Maximum activity of the radiation source

Radiation source container	⁶⁰ Co	¹³⁷ Cs
FQG61	max. 0.74 GBq (20 mCi)	max. 18.5 GBq (500 mCi)
FQG62	max. 3.7 GBq (100 mCi)	max. 111.0 GBq (3000 mCi)

⚠ CAUTION

The maximum admissible activity may be further restricted by country-specific regulations or approvals.

Dose rate diagrams

A dose rate diagram specifies the local dose rate in a specified distance from the surface of the radiation source container. Below you find examples of dose rate diagrams for FQG61 and FQG62. They are valid for a distance of 1 m (3.3 ft) and for selected activities of a ⁶⁰Co or ¹³⁷Cs radiation source. They refer to the radiation being switched OFF and Feature 020 "Version", Option model A "Cylinder lock fixation ON/OFF + covering cap". Max. values are given if switched OFF, outside of the beam path. Dose rate diagrams for other distances and activities are available on request. The dose rate diagram for the real loading and version can be ordered in Feature 580 "Test, Certificate".

Dose rate diagrams for ⁶⁰Co

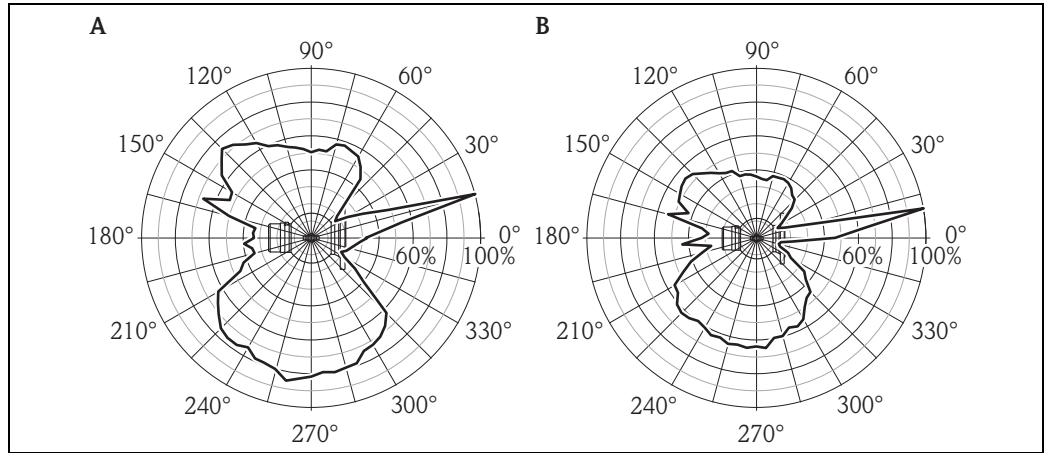

A FQG61
B FQG62

Option model in Feature 100 "Length; Prepared for Source Activity"	Activity in MBq		max. value (100%) in µSv/h	
	FQG61	FQG62	FQG61	FQG62
AA	3,7	3,7	0,04	0,01
AB	7,4	7,4	0,08	0,02
AC	18,5	18,5	0,21	0,05
AD	37	37	0,42	0,10
AE	74	74	0,85	0,20
AF	111	111	1,27	0,30
AG	185	185	2,12	0,50
AH	370	370	4,24	1,01
AK	740	740	8,49	2,02
AL	-	1110	-	3,03
AM	-	1850	-	5,04
AN	-	3700	-	10,09

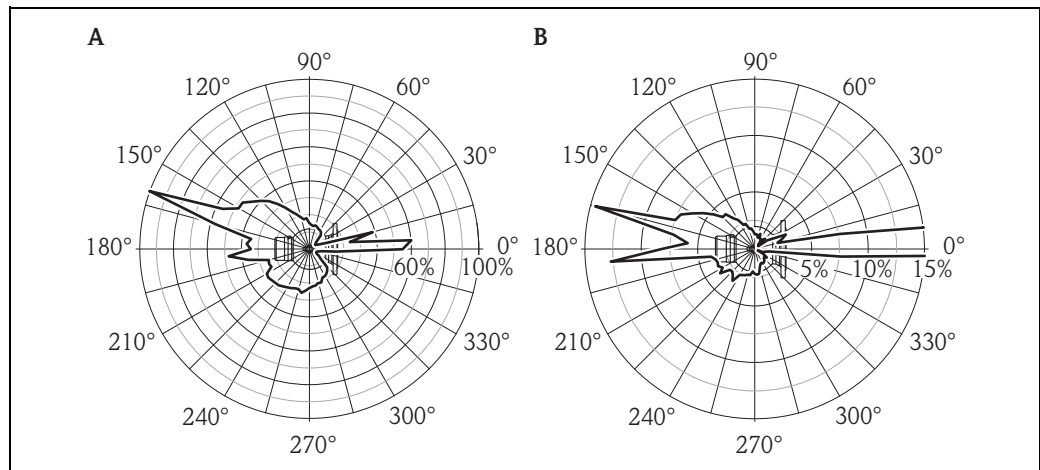

Allocation to the option, see the Product Configurator on the Endress+Hauser website:
www.endress.com → Select country → Instruments → Select device → Product page function:
 Configure this product

Dose rate diagrams for ^{137}Cs 

A0018384

A FQG61
B FQG62

Option model in Feature 100 "Length; Prepared for Source Activity"	Activity in MBq		max. value (100%) in $\mu\text{Sv/h}$	
	FQG61	FQG62	FQG61	FQG62
AA	3,7	3,7	< 0,01	< 0,01
AB	7,4	7,4	< 0,01	< 0,01
AC	18,5	18,5	0,01	< 0,01
AD	37	37	0,01	0,01
AE	74	74	0,02	0,01
AF	111	111	0,04	0,02
AG	185	185	0,06	0,03
AH	370	370	0,12	0,06
AK	740	740	0,24	0,12
AL	1110	1110	0,36	0,18
AM	1850	1850	0,60	0,30
AN	3700	3700	1,20	0,60
AP	7400	7400	2,39	1,19
AR	11100	11100	3,59	1,79
AT	18500	18500	5,98	2,98
AW	-	29600	-	4,77
BB	-	37000	-	5,96
BC	-	55500	-	8,94
BD	-	74000	-	11,91
BF	-	111000	-	17,87



Allocation to the option, see the Product Configurator on the Endress+Hauser website:
www.endress.com → Select country → Instruments → Select device → Product page function:
 Configure this product

Mechanical construction

Version

Feature 020 of the product structure	Properties	Comparable to QG020/QG100 in the following version
A	<ul style="list-style-type: none"> Source holder for manual switch-ON/switch-OFF Cylinder lock to secure switching state (ON or OFF) Covering cap 	Standard
B	<ul style="list-style-type: none"> Rotary bracket for manual switch-ON/switch-OFF Locking bolt to secure the ON switching state Padlock to secure the OFF switching state 	US, Australia
C	<ul style="list-style-type: none"> Rotary bracket for manual switch-ON/switch-OFF Padlock to secure the switching state (ON or OFF) 	Euro, Sweden, Norway
D	<ul style="list-style-type: none"> Higher protection against dust and humidity Rotary bracket for manual switch-ON/switch-OFF Padlock to secure the switching state (ON or OFF) 	Chemical
K L	<ul style="list-style-type: none"> Pneumatic switch-ON/switch-OFF Padlock to secure the OFF switching state 	Standard - with pneumatic actuator
M N	<ul style="list-style-type: none"> Higher protection against dust and humidity Pneumatic switch-ON/switch-OFF Padlock to secure the OFF switching state 	Chemical - with pneumatic actuator

Design, Dimensions

FQG61/FQG62; Feature 020, Option model A; see also → 40

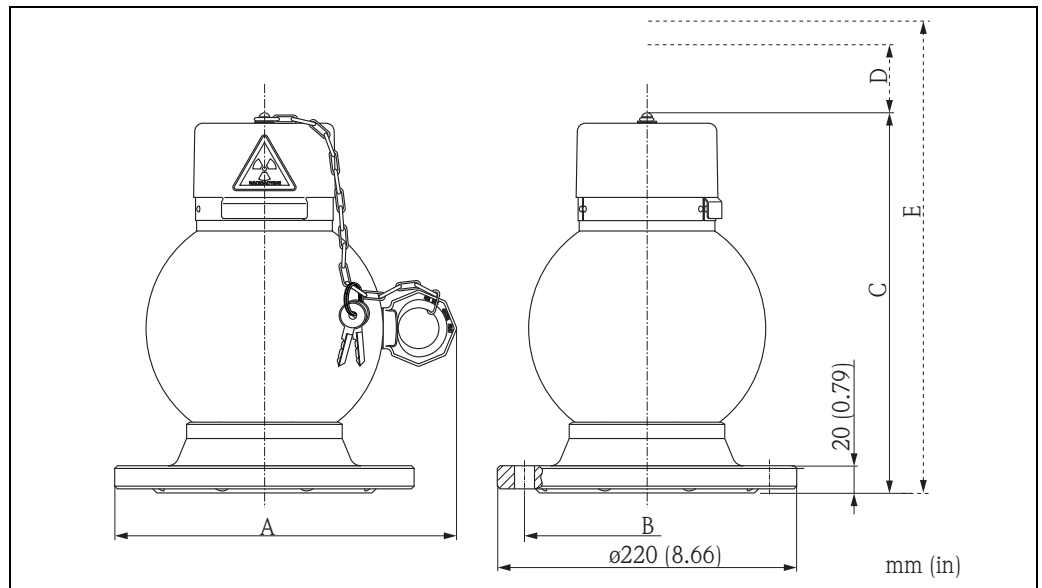

A0018385

Dimensions	Variant	mm (in)	Comment
A	FQG61	251 (9.88)	-
	FQG62	272 (10.7)	
B	The mounting flange of FQG61 and FQG62 is compatible with: DN 100 PN16 (ø 180 mm (7.09 in)) and ANSI 4" 150 lbs (ø 190 mm (7.48 in))		
C	FQG61	279 (11)	-
	FQG62	360 (14.2)	
D		75 (2.95)	Clearance for removal of the cover
E	FQG61	479 (18.9)	Clearance required for exchange of the radiation source
	FQG62	560 (22)	

FQG61/FQG62; Feature 020, Option model B; see also → 40

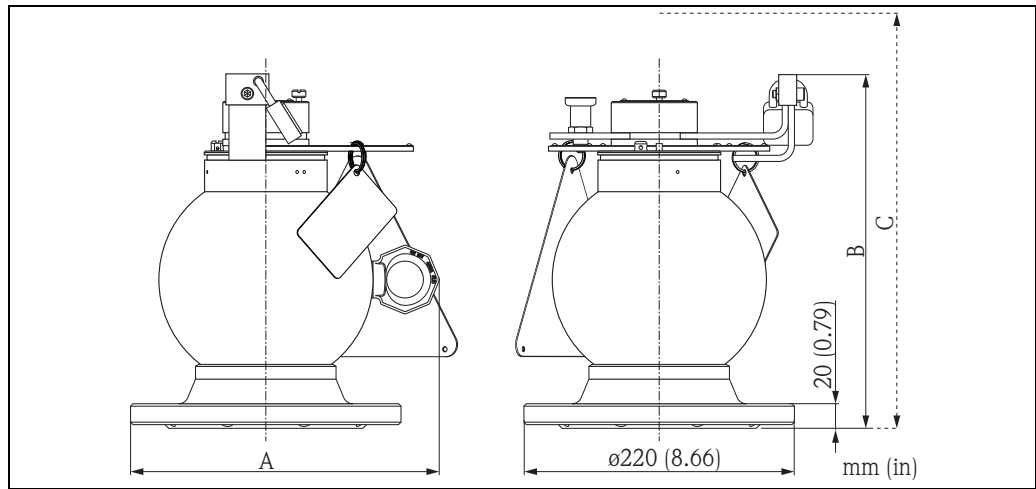

A0018386

Dimensions	Variant	mm (in)	Comment
A	FQG61	251 (9.88)	-
	FQG62	272 (10.7)	
B	FQG61	287 (11.3)	-
	FQG62	368 (14.5)	
C	FQG61	450 (17.7)	Clearance required for exchange of the radiation source
	FQG62	580 (22.8)	

FQG61/FQG62; Feature 020, Option model C; see also → 40

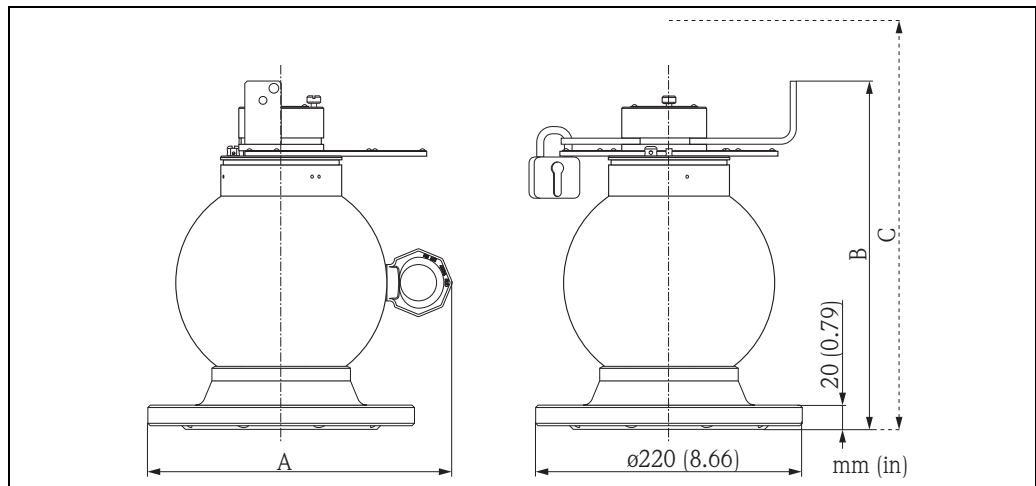

A0018387

Dimensions	Variant	mm (in)	Comment
A	FQG61	251 (9.88)	-
	FQG62	272 (10.7)	
B	FQG61	287 (11.3)	-
	FQG62	368 (14.5)	
C	FQG61	450 (17.7)	Clearance required for exchange of the radiation source
	FQG62	570 (22.4)	

FQG61/FQG62; Feature 020, Option model D; see also → 40

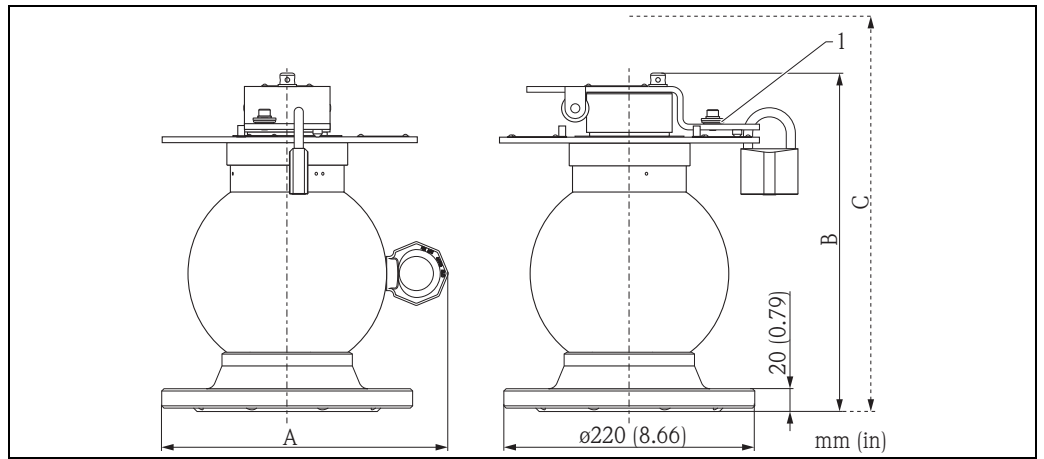

1 Reference O-Ring

Dimensions	Variant	mm (in)	Comment
A	FQG61	251 (9.88)	-
	FQG62	272 (10.7)	
B	FQG61	297 (11.7)	-
	FQG62	378 (14.9)	
C	FQG61	497 (19.6)	Clearance required for exchange of the radiation source
	FQG62	578 (22.8)	

FQG61/FQG62; Feature 020, Option model K, L, M or N; see also → 40

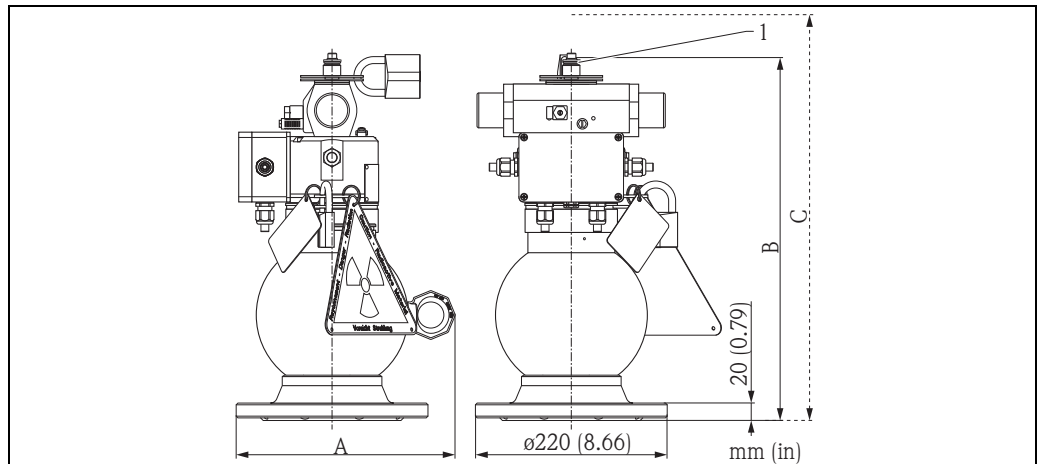

1 Reference O-Ring

Dimensions	Variant	mm (in)	Comment
A	FQG61	251 (9.88)	-
	FQG62	272 (10.7)	
B	FQG61	419 (16.5)	-
	FQG62	500 (17.9)	
C	FQG61	483 (19)	Clearance required for exchange of the radiation source
	FQG62	602 (23.7)	

Additional Function "Fire-resistant"
(FQG61/FQG62; Feature 670, Option model WE; see also → 40)

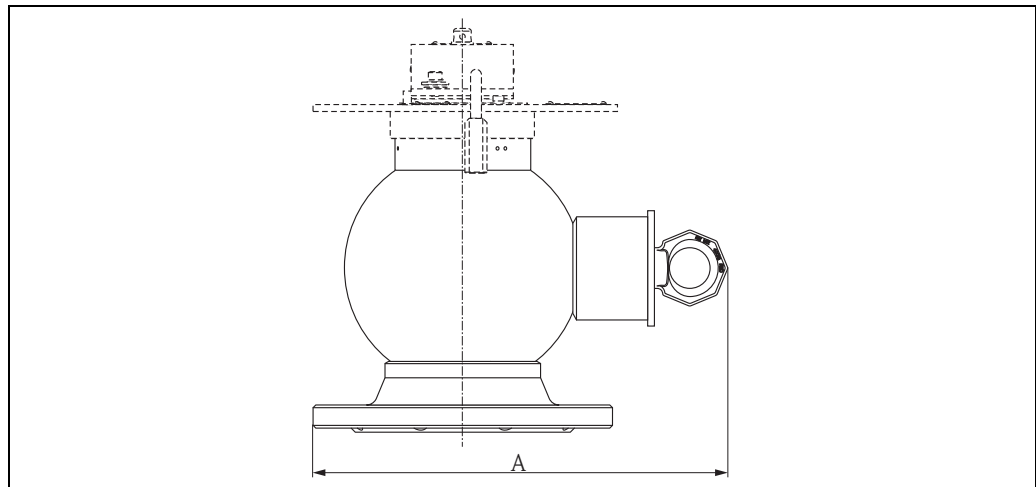

A0018390

Dimensions	Variant	mm (in)	Comment
A	FQG61	305 (12)	-
	FQG62	362 (14.3)	

Radiation emission channel

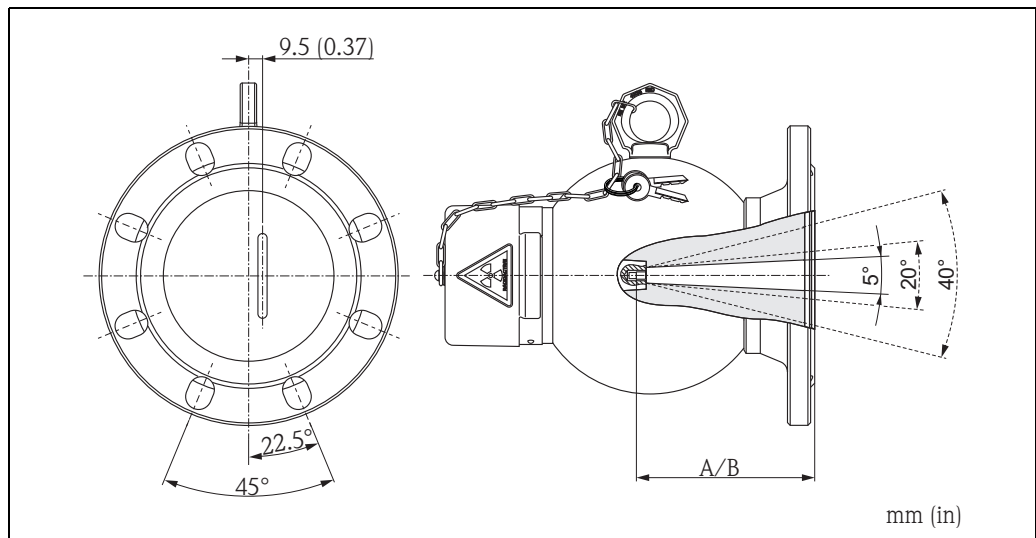

mm (in)

A0018391

- A FQG61: 123 mm (4.84 in)
B FQG62: 166 mm (6.54 in)

Position	The emission channel is located in a distance of 9.5 mm (0.37 in) from the center of the mounting flange. It has the same direction as the ring eyelet of the radiation source container. The emission channel is marked on the covering plate of the mounting flange.
Angle of emission	According to feature 240 of the product structure: <ul style="list-style-type: none"> ■ 5° ■ 20° ■ 40°
Width of emission	<ul style="list-style-type: none"> ■ FQG61: 10 mm (0.39 in) ■ FQG62: 12 mm (0.47 in)
Attenuation of the useful beam	approx. 0.3 half-value layers ($F_S = 1.2$)

Weight

Source container	With manual ON-/OFF-switching	With pneumatic actuator
FQG61	approx. 42 kg (92,61 lbs)	approx. 46 kg (101,43 lbs)
FQG62	approx. 86 kg (189,63 lbs)	approx. 90 kg (198,45 lbs)

Materials

FQG61/FQG62; Feature 020, Option model A; see also →  40

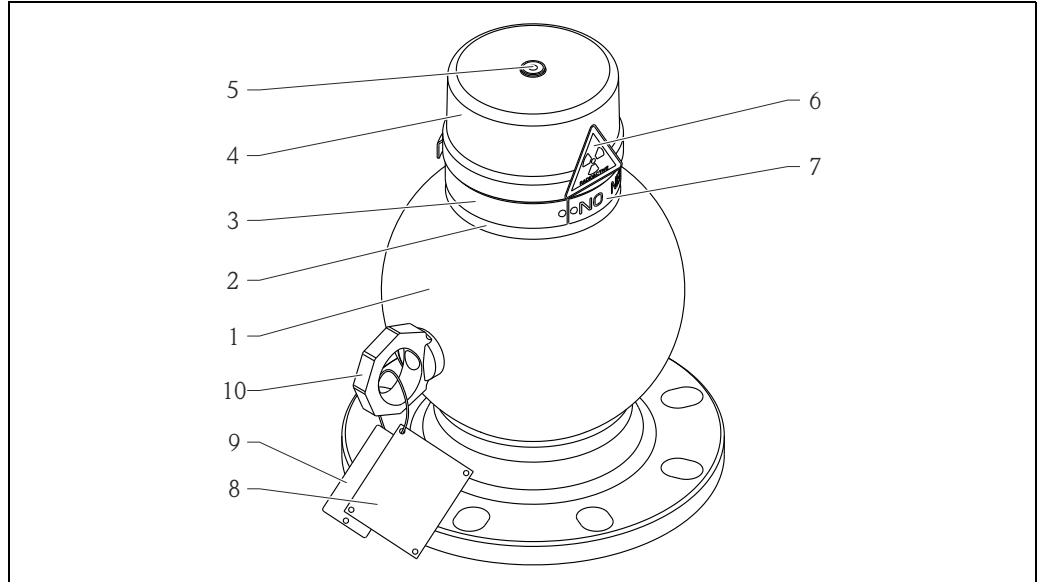

A0018393

Position	Part	Material
1	Housing, Flange	316L (1.4404); S235JR (1.0038)
2	Housing ring	316L (1.4404); 304 (1.4301)
3	Nameplate	VA
4	Cover	304 (1.4301)
	O-ring	FKM
5	Screw/groove pin	A2
6	Warning plate	Acrylate foil
7	Nameplate radiation source	304 (1.4301)
8	Tag	304 (1.4301)
	Rope	316 (1.4401)
9	Tag	304 (1.4301)
	Rope	316 (1.4401)
10	Ring eye	C15; A2

Position	Part	Varnish
1	Housing, Flange	PUR 2K-texture paint RAL 1003
4	Cover	

FQG61/FQG62; Feature 020, Option model B; see also → 40

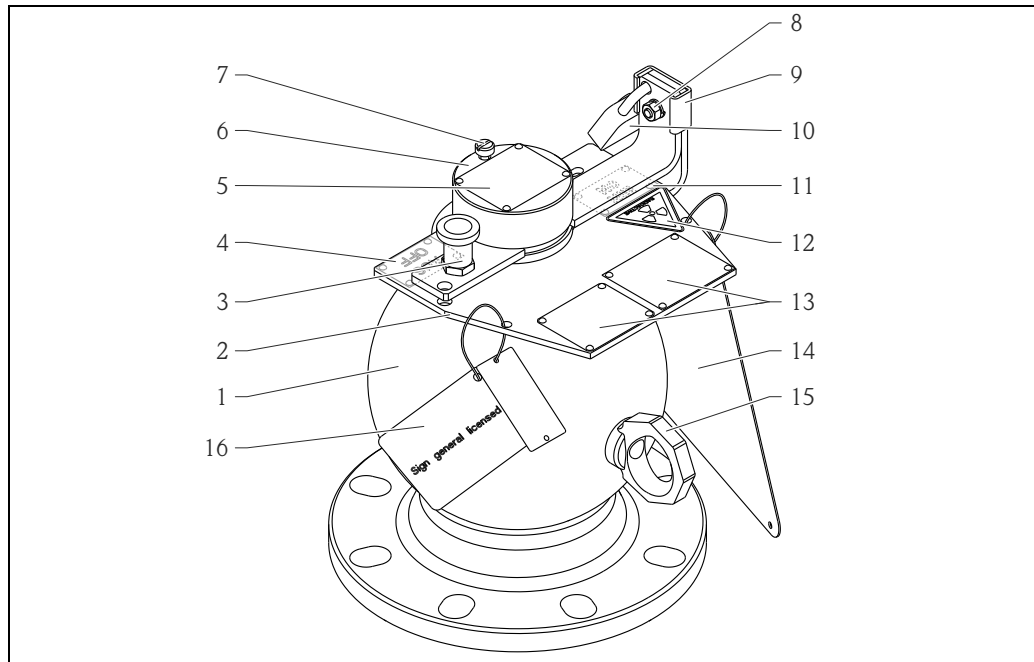

A0018394

Position	Part	Material
1	Housing, Flange	316L (1.4404); S235JR (1.0038)
2	Indication plate	316L (1.4404)
3	Rotating pin	316L (1.4404)
4	Tag "AUS/OFF"	304 (1.4301)
5	Nameplate "Radiation source"	304 (1.4301)
6	Rotor	316L (1.4404)
7	Screw	V4A (1.4404)
8	Screw	A4
	Screw nut	A4
9	Holder	V4A (1.4404)
10	Padlock	-
11	Tag "EIN/ON"	304 (1.4301)
12	Warning plate "Radioactive"	Acrylat foil
13	Additional tag Norway	304 (1.4301)
	Nameplate "Container"	304 (1.4301)
14	Tag "Caution Radiation"	304 (1.4301)
15	Ring eye	C15; A2
16	Tag	304 (1.4301)
	Rope	316 (1.4401)

Position	Part	Varnish
1	Housing, Flange	PUR 2K-texture paint RAL 1003

FQG61/FQG62; Feature 020, Option model C; see also → 40

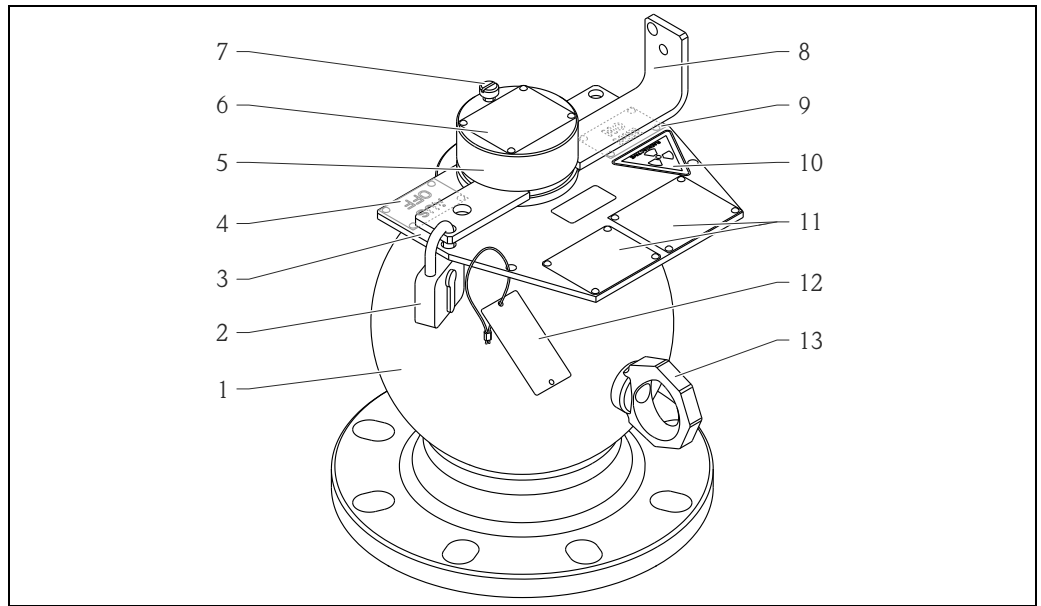

A0018395

Position	Part	Material
1	Housing, Flange	316L (1.4404); S235JR (1.0038)
2	Padlock	-
3	Indication plate	316L (1.4404)
4	Tag "AUS/OFF"	304 (1.4301)
5	Rotor	316L (1.4404)
6	Nameplate "Radiation source"	304 (1.4301)
7	Screw	V4A (1.4404)
8	Rotary bracket	316L (1.4404)
9	Tag "EIN/ON"	304 (1.4301)
10	Warning tag "Radioactive"	Acrylate foil
11	Additional tag Sweden	304 (1.4301)
	Nameplate "Container"	304 (1.4301)
12	Tag	304 (1.4301)
	Rope	316 (1.4401)
13	Ring eye	C15; A2

Position	Part	Varnish
1	Housing, Flange	PUR 2K-texture paint RAL 1003

FQG61/FQG62; Feature 020, Option model D; see also → 40

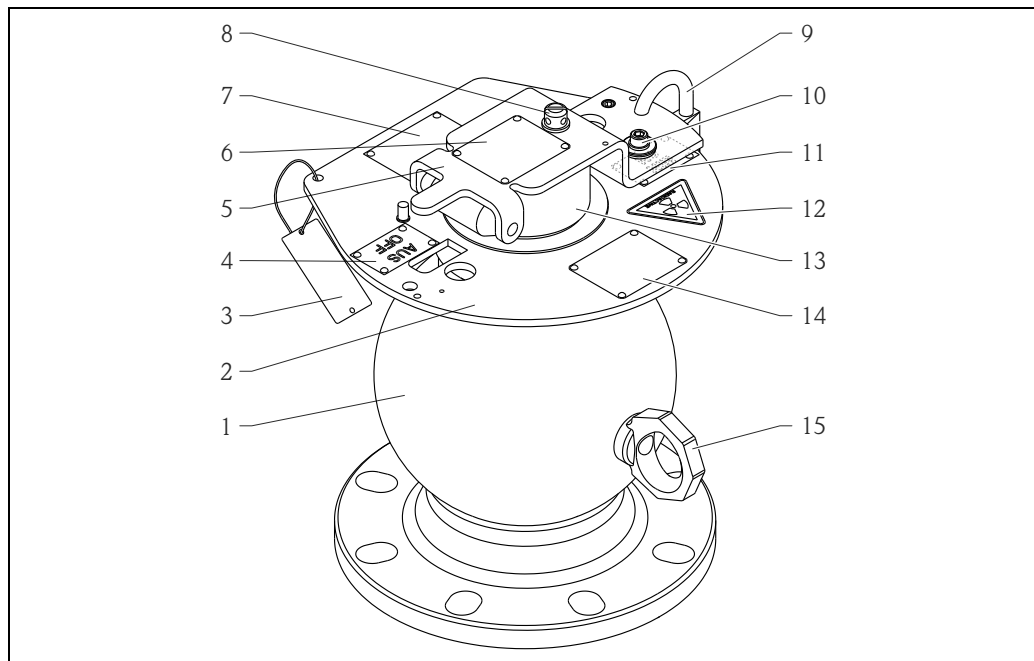

A0018396

Position	Part	Material
1	Housing, Flange	316L (1.4404); S235JR (1.0038)
2	Indication plate	316L (1.4404)
3	Tag	304 (1.4301)
	Rope	316 (1.4401)
4	Tag "AUS/OFF"	304 (1.4301)
5	Rotary bracket	316L (1.4404)
6	Name plate "Radiation source"	304 (1.4301)
7	Additional tag Sweden	304 (1.4301)
8	Mounting	A2-70
9	Padlock	-
10	Screw	A4-70
	Spring washer	A2
	Protector cap	304 (1.4301)
	Reference O-ring	FKM
11	Tag "EIN/ON"	304 (1.4301)
12	Warning tag "ACHTUNG!"	Acrylat foil
13	Rotor	316L (1.4404)
14	Nameplate "Container"	304 (1.4301)
15	Ring eye	C15; A2

Position	Part	Varnish
1	Housing, Flange	PUR 2K-texture paint RAL 1003

FQG61/FQG62; Feature 020, Option model K, L, M or N; see also → 40

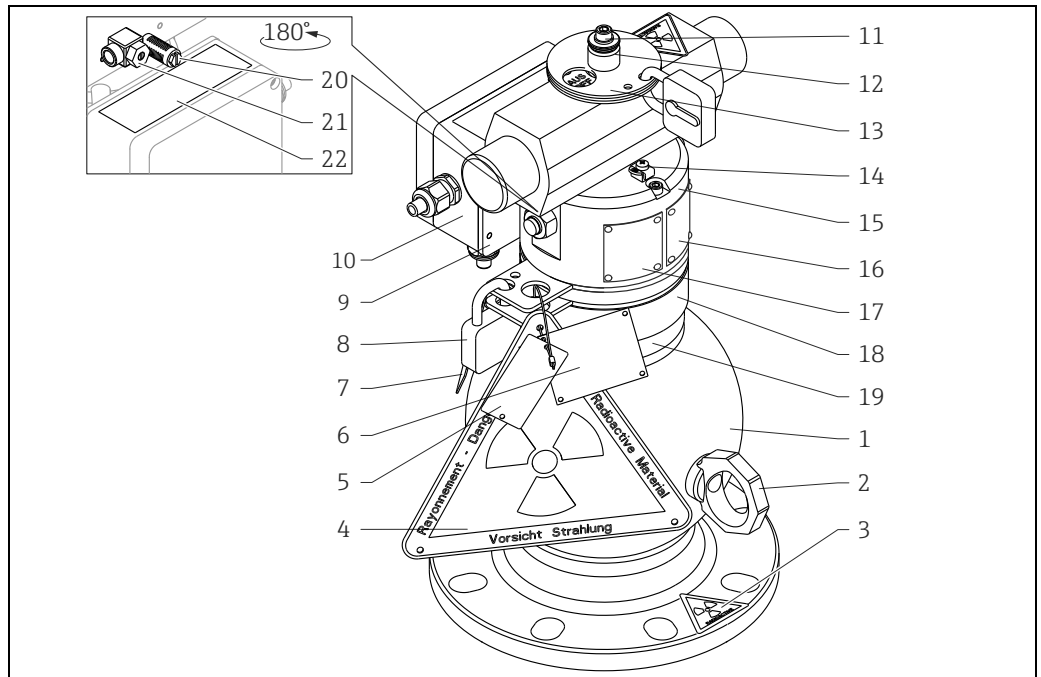

A0018397

Position	Part	Material
1	Housing, Flange	316L (1.4404); S235JR (1.0038)
2	Ring eye	C15; A2
3	Warning tag "Radioactive"	Acrylat foil
4	Tag "Caution radiation"	304 (1.4301)
5, 6	Tag	304 (1.4301)
7	Tag "Radioactiv material"	304 (1.4301)
8	Padlock	-
9	Mounting plate	316L (1.4404)
10	Terminal block	PC
11	Screw	A2-70
	Spring washer	301 (1.4310)
	Protector cap	304 (1.4301)
	Reference O-ring	FKM
12	Ferrule	316L (1.4404)
13	Disk	316L (1.4404)
14	Ground terminal	Screw: A4; Spring washer: A4; Clamp: 316L (1.4404); Holder: 316L (1.4404)
15	Cap	316L (1.4404)
16	Nameplate "Australia"	304 (1.4301)
17	Nameplate "Container"	304 (1.4301)
18	Adapter disk	316L (1.4404)
19	Nameplate "Präparat"	304 (1.4301)
20	Muffler G1/8	PVC
21	Check valve G1/8	MS
22	Nameplate "Pneumatik/ATEX"	Laser foil

Position	Part	Varnish
1	Housing, Flange	PUR 2K-texture paint RAL 1003
16	Nameplate "Australia"	

Safety equipment A padlock, cylinder lock or locking bolt (depending on the instrument version) provide the following:

- Security of the switching state ("ON" or "OFF")
- Theft protection

Pneumatic actuator The following is valid for the version with pneumatic cutoff for ON/OFF switching:

- Swivel range: 180°
- Compressed air connection: G1/8
- Actuating pressure: 3.5 to 6 bar (51 to 87 psi)
- Reset by means of spring
- Required air quality: Class 5 according to ISO 8573-1, pressure dewpoint 10 K below operating temperature.

NOTICE

For compressed air (Gas Group 2) in Europe the pneumatic actuator is excluded from the requirements of the Pressure Equipment Directive 97/23/EC based on article 1, clause 3.6 of the directive.

Ambient conditions

Ambient temperature

Version	Ambient temperature
Manually operated	-40 to +200 °C (-40 to +392 °F)
Pneumatic actuator	-20 to +80 °C (-4 to +176 °F)

Ambient pressure Atmospheric pressure

Vibration resistance DIN EN 60068-2-64 test Fh; 10 to 2000 Hz; 1 g²/Hz

Fire

- For all versions: 5 min. @ +538 °C (+1000 °F) according to ANSI N 43.8
- For the fire-resistant version (Feature 670 "Additional Function", Option WE): 30 min. @ +821 °C (+1510 °F) according to ISO 7205

Degree of protection IPx6 and NEMA TYPE 4

Identification

Nameplates

FQG61/FQG62; Feature 020, Option model A; see also → 40

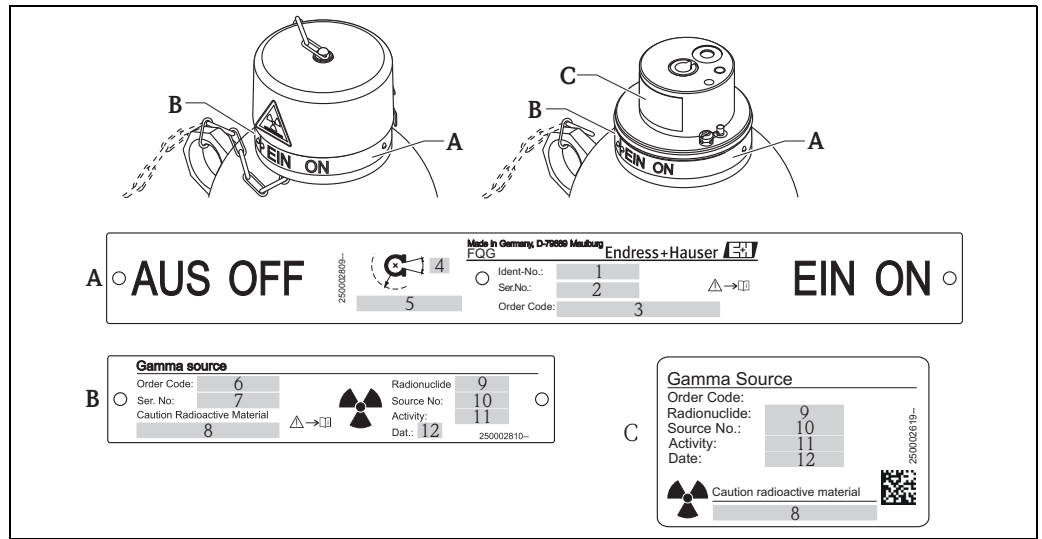

A0018398

- A Nameplate "radiation source container"
 B Nameplate "source capsule"
 C Additional label "source capsule"

- 1 Ident number of radiation source container
 2 Serial number of radiation source container
 3 Order code of radiation source container according to product structure (→ 40)
 4 Radiation emission angle
 5 Local dose rate at a defined distance from the surface (if switched off; outside the path of the beam)
 6 Endress+Hauser internal order code of the radiation source
 7 Endress+Hauser internal serial number of the radiation source
 8 Wording "Hochradioaktive Strahlenquelle" (acc. to German regulations), if required¹⁾
 9 "Cs137" or "Co60"
 10 Serial number of the source capsule (according to certificate of the supplier)
 11 Activity including unit (MBq or GBq)
 12 Date of loading (month/year)

NOTICE

The local dose rate at a defined distance specified on the nameplate is based on a worst-case estimation if switched off, outside the path of the beam and takes into account production-dependent fluctuations of the source activity and tolerances of the measuring devices. Therefore it may be slightly different from the local dose rate which can be calculated from the specified attenuation factors (→ 6).

1) Required by German regulations

FQG61/FQG62; Feature 020, Option model B, C or D; see also → 40

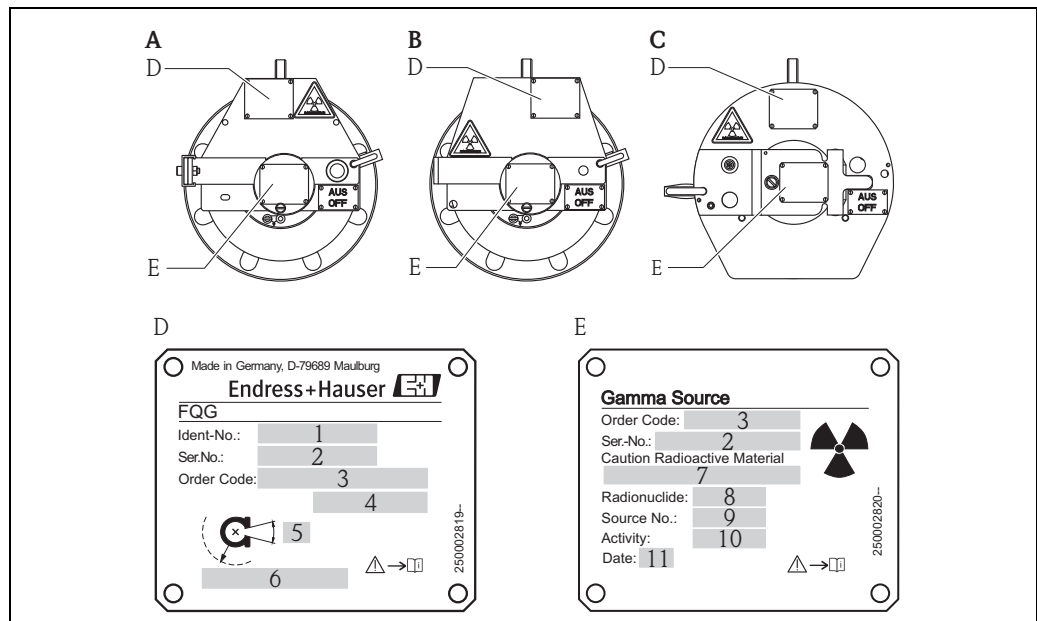

- A FQG61/FQG62; Feature 020, Option model B
 B FQG61/FQG62; Feature 020, Option model C
 C FQG61/FQG62; Feature 020, Option model D
 D Nameplate "radiation source container"
 E Nameplate "source capsule"

- 1 Ident number of radiation source container
 2 Serial number of radiation source container
 3 Order code of radiation source container according to product structure (→ 40)
 4 Order code of radiation source container according to product structure (→ 40)
 5 Radiation emission angle
 6 Local dose rate at a defined distance from the surface (if switched off: outside the path of the beam)
 7 Wording "Hochradioaktive Strahlenquelle" (acc. to German regulations), if required
 8 "Cs137" or "Co60"
 9 Serial number of the source capsule (according to certificate of the supplier)
 10 Activity including unit (MBq or GBq)
 11 Date of loading/change (month/year)

NOTICE

The local dose rate at a defined distance specified on the nameplate is based on a worst-case estimation if switched off, outside the path of the beam and takes into account production-dependent fluctuations of the source activity and tolerances of the measuring devices. Therefore it may be slightly different from the local dose rate which can be calculated from the specified attenuation factors (→ 6).

FQG61/FQG62; Feature 020, Option model K, L, M or N; see also → 40

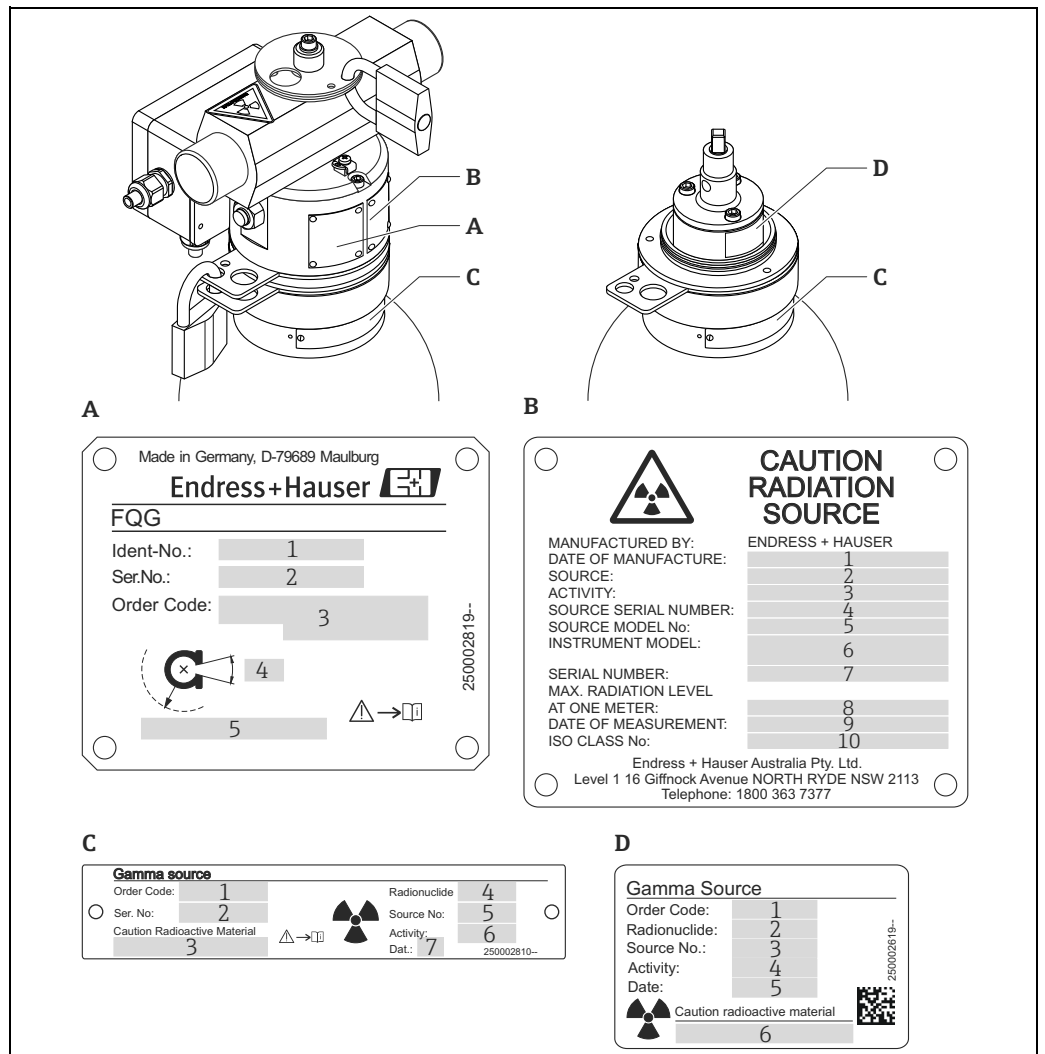

- A** Nameplate "radiation source container"
- 1 Ident number of radiation source container
 - 2 Serial number of radiation source container
 - 3 Order code of radiation source container according to product structure (→ 40)
 - 4 Radiation emission angle
 - 5 Local dose rate at a defined distance from the surface (if switched off: outside the path of the beam)
- B** Additional label "Australia"
- 1 Manufacturing date of the radiation source
 - 2 "Cs137" or "Co60"
 - 3 Activity including unit (MBq or GBq)
 - 4 Serial number of the radiation source
 - 5 Order code of radiation source
 - 6 Endress+Hauser internal order code of the radiation source
 - 7 Endress+Hauser internal serial number of the radiation source
 - 8 Local dose rate at a distance of 1 m (3.3 ft)
 - 9 Test date of the container
 - 10 Material class of the radiation source
- C** Nameplate "source capsule"
- 1 Endress+Hauser internal order code of the radiation source
 - 2 Endress+Hauser internal serial number of the radiation source
 - 3 Wording "Hochradioaktive Strahlenquelle" (acc. to German regulations), if required
 - 4 Cs137" oder "Co60"
 - 5 Serial number of the source capsule (according to certificate of the supplier)
 - 6 Activity including unit (MBq or GBq)
 - 7 Date of loading/change (month/year)
- D** Additional label "source capsule"
- 1 Endress+Hauser internal order code of the radiation source
 - 2 "Cs137" or "Co60"
 - 3 Serial number of the source capsule (according to certificate of the supplier)
 - 4 Activity including unit (MBq or GBq)
 - 5 Date of loading/change (month/year)
 - 6 Wording "Hochradioaktive Strahlenquelle" (acc. to German regulations), if required

NOTICE

The local dose rate at a defined distance specified on the nameplate is based on a worst-case estimation if switched off, outside the path of the beam and takes into account production-dependent fluctuations of the source activity and tolerances of the measuring devices. Therefore it may be slightly different from the local dose rate which can be calculated from the specified attenuation factors (→ 6).

Installation

Incoming acceptance

The radiation source container serves as a type-A packaging (IATA rules) for the radiation source. For transport, it is protected by a foam packaging in a carton.

Dimensions of the packaging:

- without pneumatic actuator: 380 x 380 x 450 mm (15 x 15 x 17.7 in)
- with pneumatic actuator: 380 x 380 x 600 mm (15 x 15 x 23.6 in)

NOTICE

The foam packaging can be disposed like ordinary consumer waste.

Transport

⚠ WARNING

Transport of source container

- ▶ Transport the radiation source container according to the figure below.
- ▶ When using an annular strap (1), the suspension point must be above the center of gravity of the radiation source container therefore the additional strap (2) prevents the radiation source container from swinging or tilting.

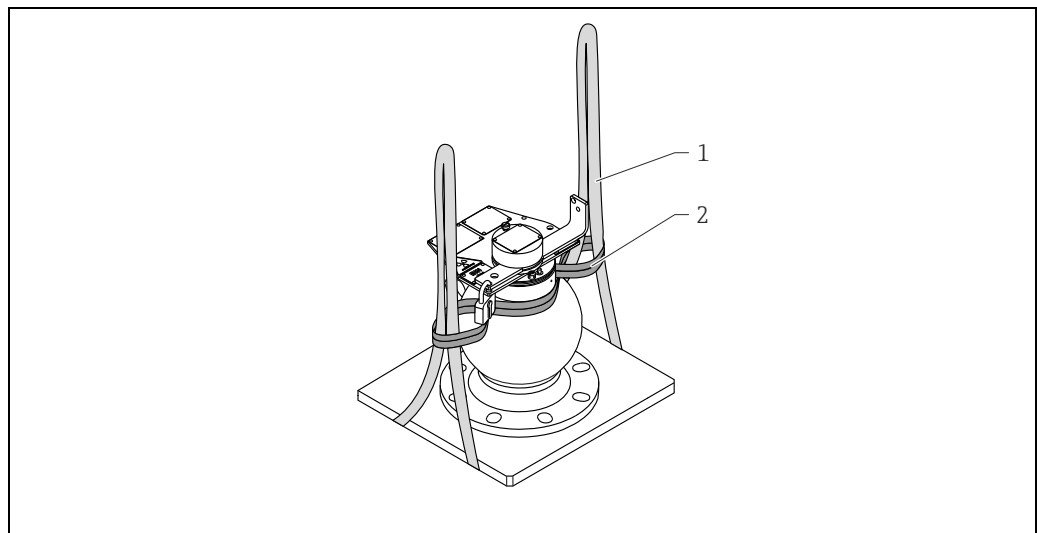

A0022393

Mounting hints

The radiation source container can be mounted in one of the following ways:

- By a nozzle directly on the vessel or pipe (not pressurized and not in contact with process)
- On an external construction with low to zero vibration

⚠ CAUTION

Mounting of source container

- ▶ All maintenance such as mounting, removal or replacement of the radioactive source may only be carried out by supervised personnel who have been specially trained in radiation procedures according to local regulations or handling approval. Ensure that the contents of the handling approval are valid. Local conditions are to be observed.
- ▶ All work must be carried out as quickly as possible and from a distance as large as possible (shielding!). Safety procedures (e.g. blocking of access) must also be carried out to protect personnel from all possible risk.
- ▶ Mounting and dismounting is only allowed in the "OFF" position, secured with a lock.
- ▶ Take into account the weight of the radiation source container:
 - FQG61: 40 to 50 kg (88.2 to 110.25 lbs)
 - FQG62: 87 to 97 kg (191.84 to 213.89 lbs)

Mounting position for level measurement

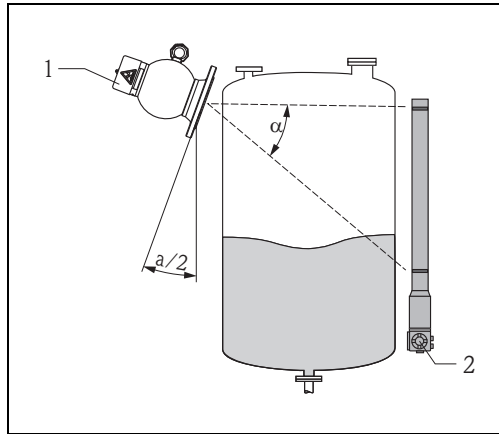

1 FQG61, FQG62
2 FMG60

The source container must be mounted at the height of, or slightly above, the maximum level for continuous level measurement. The radiation must be aligned exactly with the compact transmitter mounted opposite. The source container and compact transmitter should be mounted as close as possible to the product container to avoid control zones.

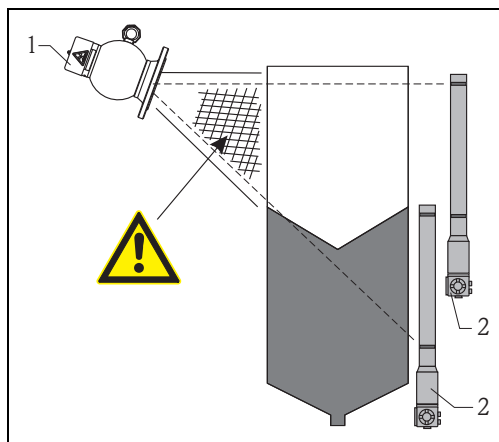

1 FQG61, FQG62
2 FMG60

A distance between the source container and the product container often cannot be avoided if the measuring range is large and the container diameter small. This space must then be blocked off and marked.

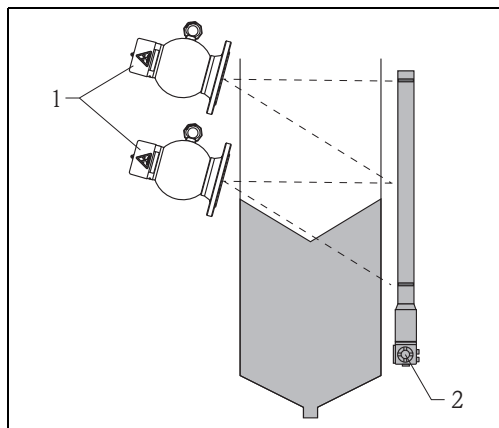

1 FQG61, FQG62
2 FMG60

In general two or more source containers are used for large measuring ranges. The use of several sources can be necessary not only from the aspect of large measuring ranges but also for accuracy reasons.

Mounting position for level limit detection

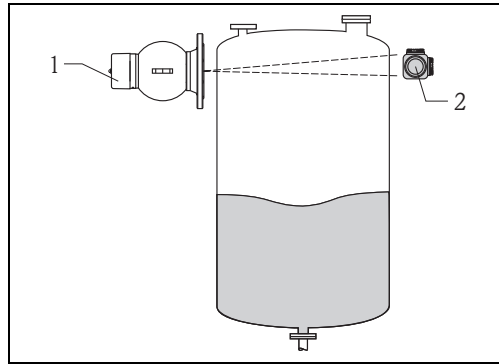

- 1 FQG61, FQG62
2 FMG60

The version of the radiation source container with the angle of emission $\alpha = 5^\circ$ is recommended for level limit detection. If larger angles of emission (20° or 40°) are used, ensure that the ray is horizontal.

For this purpose, mount the radiation source container in such a way that the eyelet is positioned horizontally.

Mounting position for density measurement

The most constant conditions for density measurement in pipes are achieved if the unit is mounted on vertical pipe lines and the feed direction is from bottom to top. If only horizontal pipes are accessible, the path of the ray should also be arranged horizontally to reduce the influence of air bubbles and build-up.

In order to achieve a longer path of the radiation through the medium and thus a larger measuring effect, a diagonal beam or a measuring path can be applied:

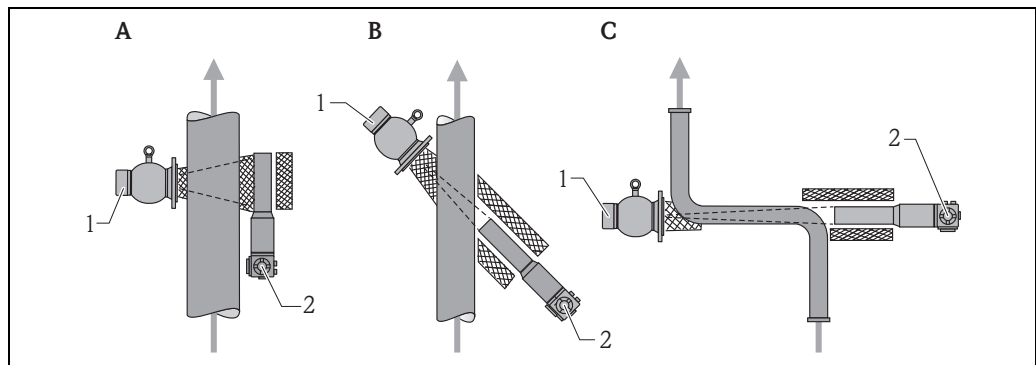

- A Vertical beam
B Diagonal beam
C Measuring path
1 FQG61, FQG62
2 FMG60

The following accessories are available for mounting the radiation source container and the FMG60 compact transmitter to pipes:

- Clamping device FHG61 (→ 41)
- Measuring path FHG62 (→ 42)

Orientation of the fireproof version

Orientation A (recommended)

The source container is mounted with the compensation compartment on the top. In case of fire only the emission channel will be closed by the liquefied lead.

NOTICE

After a fire, the screening is slightly reduced in the upper area of the container.

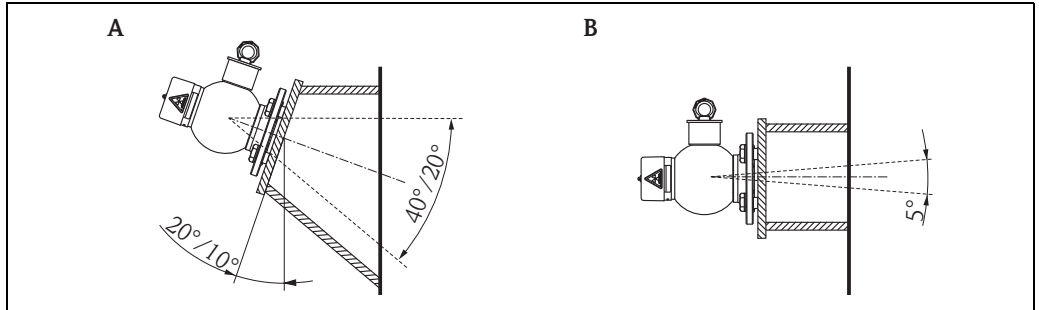

A0018406

A Level measurement
B Level limit detection

Orientation B (only if orientation A is impossible due to lack of space)

The source container is mounted with the compensation compartment at the bottom or in lateral position. In case of fire the emission channel and the compensation compartment will be filled with the liquefied lead.

NOTICE

After a fire, the screening will be strongly reduced in the upper area of the source container.

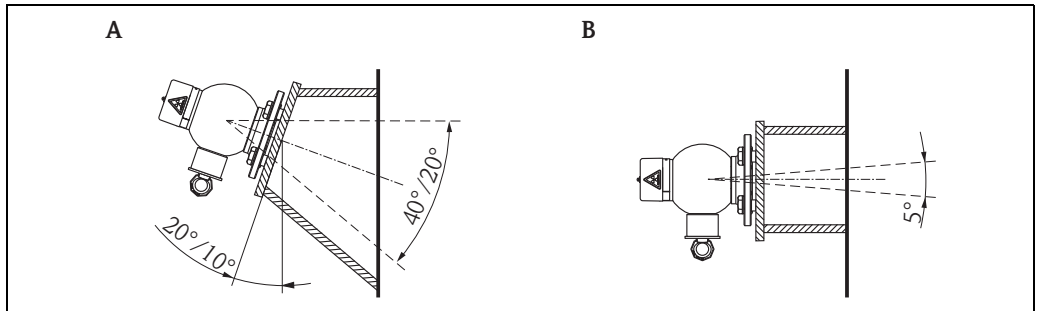

A0018407

A Level measurement
B Level limit detection

**Mounting device
(supplied by customer)**

A mounting plate or L-profiles can be used for mounting of the radiation source container:

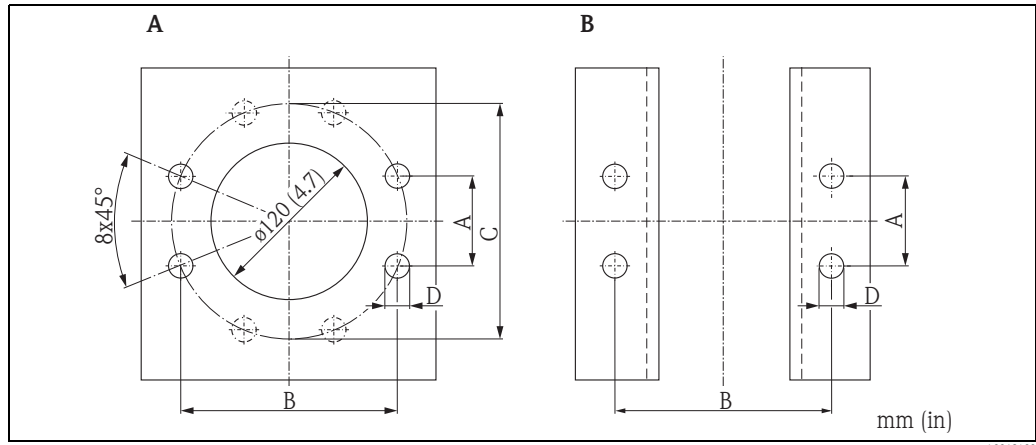

A Example of a mounting plate
B Example of L-profiles

Dimensions	EN	ANSI
A mm (in)	68,9 (2.71)	72,9 (2.87)
B mm (in)	166,3 (6.55)	176,0 (6.93)
C mm (in)	180,0 (7.09)	190,5 (7.5)
D mm (in)	18,0 (0.71)	19,1 (0.75)

- i** The mounting flange of FQG61 and FQG62 is compatible with:
- DN 100 PN16
 - ANSI 4" 150lbs

Toothed lock washers

The device must be integrated in the potential equalization of the plant. In order to ensure electrical contact between the radiation source container and the mounting support, the supplied toothed lock washers have to be installed at two of the mounting screws according to the picture on the right.

⚠ CAUTION
Apply the prescribed torque for the mounting screws. Make sure that the bolts have electrical contact to the potential equalization.

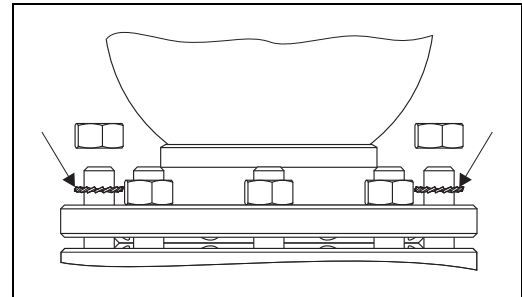

Torque for the mounting screws

Material	Property class	Coefficient of friction (μ)	Torque
SS	70	0.14	50 to 140 Nm (36.87 to 103.25 lbf ft)
Steel	8.8	0.14	50 to 140 Nm (36.87 to 103.25 lbf ft)

Post-installation check

Measuring the local dose rate

The local dose rate in the vicinity of the source container and the detector must be measured immediately after it has been mounted.

▲ CAUTION

Depending on the installation, radiation can also occur outside the actual beam-emitting channel through scattering. In such cases it must be screened by the use of additional lead or steel sheeting. Render or mark all control and exclusion areas as prohibited for unauthorised entry.

Behavior on empty process vessel

▲ CAUTION

After the skilled mounting, the control area of the empty tank has to be measured. If it is necessary, this area must be blocked off and marked. If there is an entry into the interior space of the tank, it has to be closed and marked with a sign "radioactive". The entry is only allowed after checking all safety regulation by the responsible radiation protection officer. If maintenance operations are carried out in or at the vessel, it is mandatory to switch the radiation OFF.

Connection of the pneumatic actuator

NOTICE

This chapter is only valid for radiation source containers with pneumatic actuator.
(In the product structure: Feature 020, options K, L, M or N)

CAUTION

The pneumatic actuator may only be put into operation after the radiation source container has been mounted.

Compressed-air connection

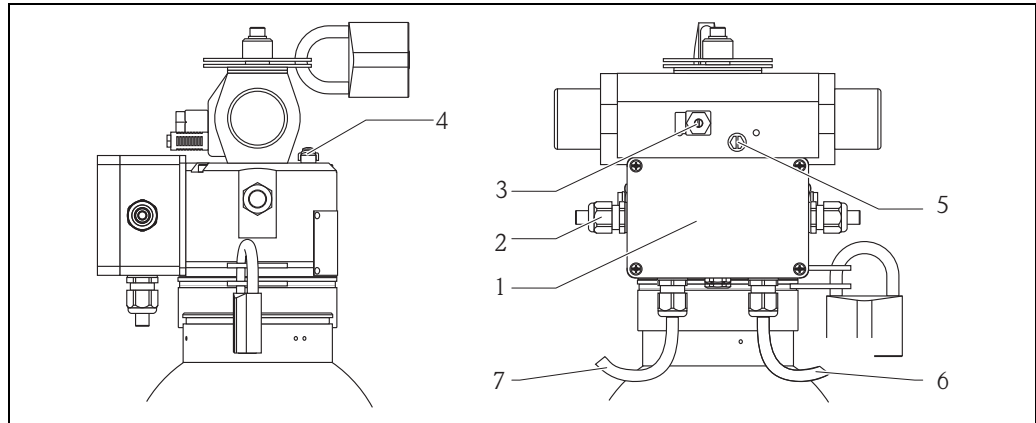

- 1 Terminal box for connection of the proximity switches
 2 Cable glands for cable diameter 5 mm to 10 mm (0,2" to 0,4")
 3 Throttle check valve for compressed air connection
 4 Connector for potential equalization
 5 Vent
 6 AUS/OFF
 7 EIN/ON

A0018411

The compressed air line is connected to the throttle check valve.

CAUTION

The throttle check valve is adjusted at the factory and secured with screw lock - do not change!

Connection of the proximity switches

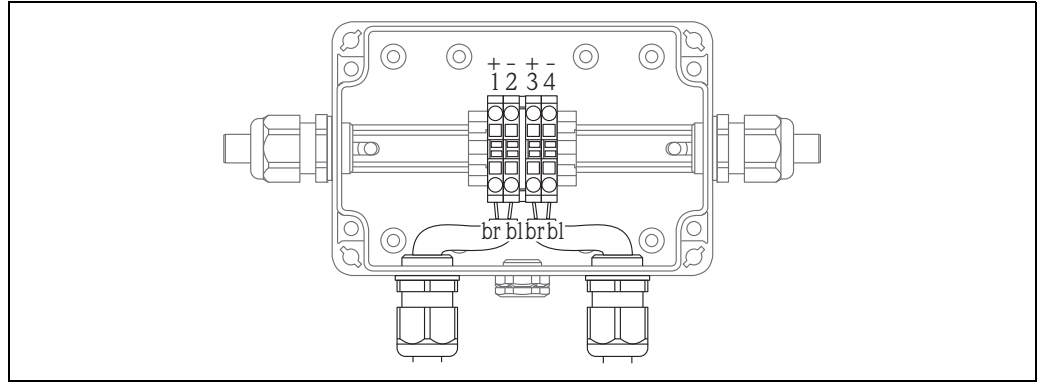

Terminals 1/2 Proximity switch for "Radiation ON"
 Terminals 3/4 Proximity switch for "Radiation OFF"

A0018412

Proximity switches

Type: Pepperl+Fuchs 181094-NCB2-12GM35-NO-10M

Cable entry

Suitable for cable diameters: 5 to 10 mm (0.2 to 0.39 in)

Potential equalization

Connector for the potential equalization line on the covering cap (→ [28](#))

Connection data

- Nominal voltage: 8V
- Current consumption
 - Measuring plate not detected: ≥ 3 mA
 - Measuring plate detected: ≤ 1 mA

Switch amplifier

For signal evaluation, the following isolating switch amplifiers can be used:

- Nivotester FTL325N (Endress+Hauser)
- KFA6-SH-Ex1, 230 V AC (Pepperl+Fuchs)
- KFD2-SH-Ex1, 24 V DC (Pepperl+Fuchs)

Commissioning

Before commissioning, the compressed air supply has to be connected and the padlock (1) on the top of the instrument has to be removed. In case of revisions this padlock must be locked again in the OFF position. In the meantime insert the padlock in the second padlock or keep it at a place outside the installation.

The lower padlock (2) blocks access to the radiation source and must not be opened during normal operation.

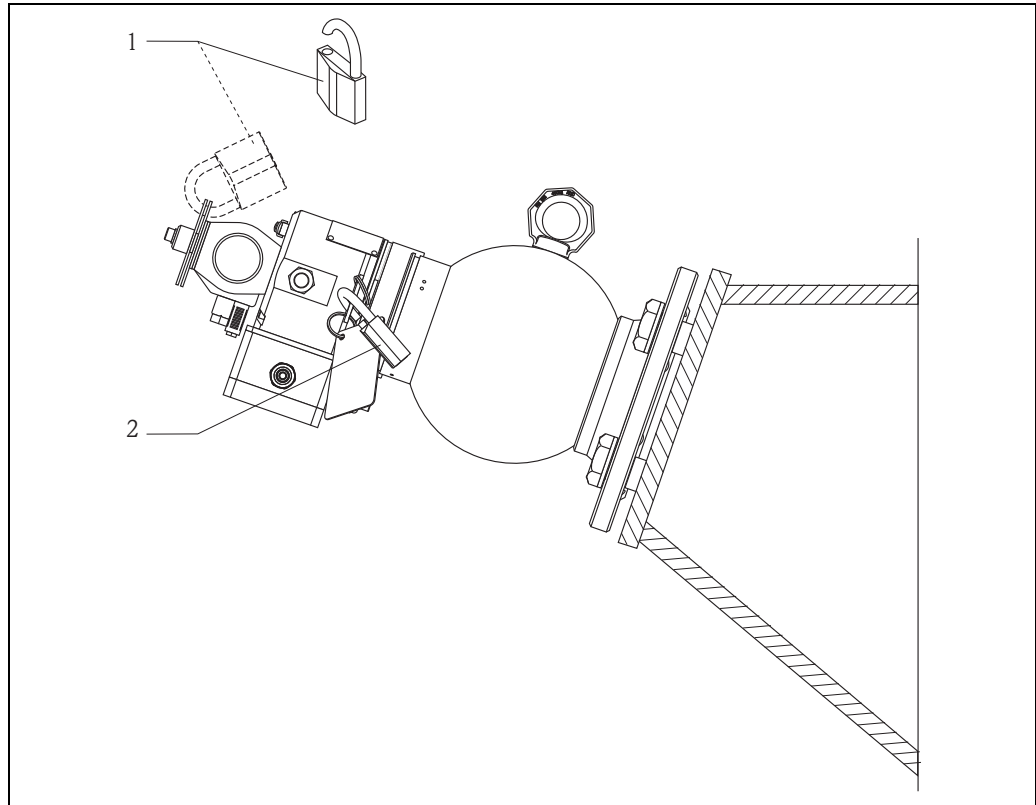

A0018413

- 1 Padlock for securing the OFF position - remove when operating the pneumatic actuator
 2 Padlock for securing the radiation source - must not be removed during normal operation

Reading the switch status

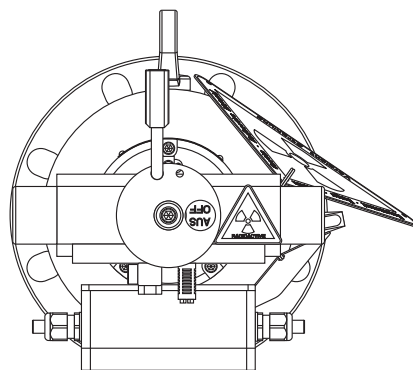

A0018414

The current switching state is marked by the visible sign ("EIN - ON" or "AUS - OFF"). The currently invalid sign is covered by the disc at the pneumatic actuator.

CAUTION

Do not touch the indication window when the actuator is pressurized.

Technical data of the pneumatic actuator

- Swivel range: 180°
- Compressed air connection: G1/8
- Actuating pressure: 3.5 to 6 bar (51 to 87 psi)
- Reset by means of spring
- Required air quality: Class 5 according to ISO 8573-1, pressure dew point 10 K below operating temperature

Operation

FQG61/FQG62;
Feature 020, Option model A

Safety instructions for switching on the radiation

- Before switching ON the radiation it is necessary to ensure that no personnel are within the area of the radiation (or, indeed, inside the vessel).
- The radiation beam may only be switched ON by specially trained personnel.

Switching radiation ON

Source container is in the OFF position.

1. Press the covering cap hard against the source container and turn the covering cap approx. 45° counterclockwise until the limit stop.
2. Remove the cap.
3. Unlock lock with key. Turn closing cylinder with key approx. 45° counterclockwise until the limit stop.
4. Pull out lock until the limit stop.
5. Only for source container with feature 670 "Additional Function", option model WA "Density measurement > fixation ON": Loosen setscrew using Allen key.
6. Turn insert 180° counterclockwise.

⚠ WARNING

Do not press the sealed locking pin (1). Rotating the insert over the locking pin leads to the removal position of the source holder.

7. Press in lock with key and turn approx. 45° clockwise.
8. Only for source container with feature 670 "Additional Function", option model WA "Density measurement > fixation ON": Screw in setscrew (SW5).

NOTICE

The current switching state is indicated by the marking arrow (2) ("EIN-ON" or "AUS-OFF").

9. Put on the covering cap.
Position "EIN-ON" must be visible.

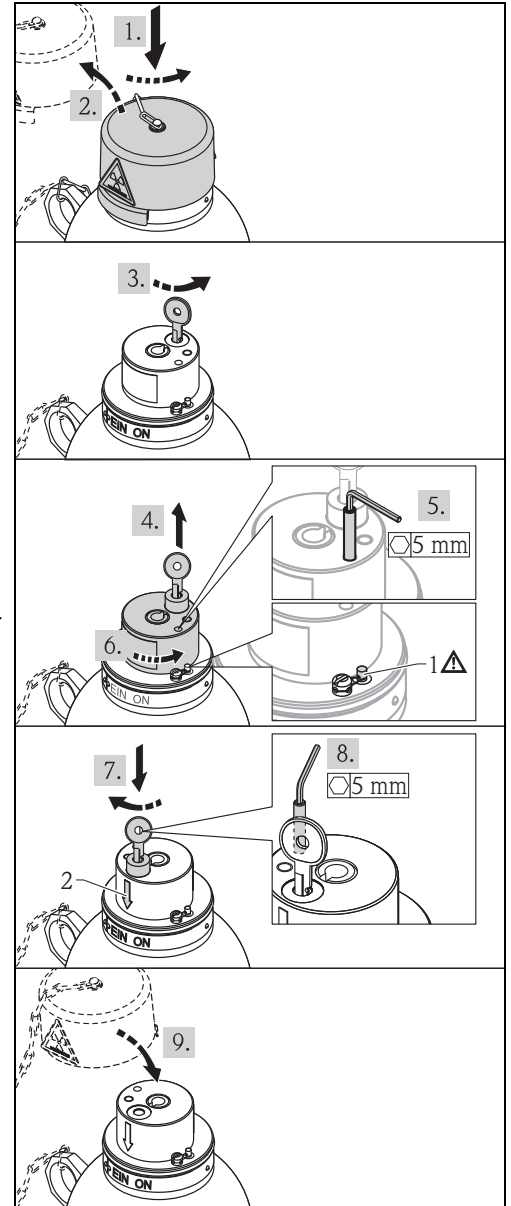

A0018415

Switching radiation OFF

Proceed in the same way to switch the radiation off. To switch the radiation off, the insert must be turned 180° clockwise.

Reading the switch status

- Radiation ON: The "EIN - ON" sign is visible. The arrow points to "EIN - ON".
- Radiation OFF: The "AUS - OFF" sign is visible. The arrow points to "AUS - OFF".

FQG61/FQG62;
Feature 020, Option model B

Safety instructions for switching on the radiation

- Before switching ON the radiation it is necessary to ensure that no personnel are within the area of the radiation (or, indeed, inside the vessel).
- The radiation beam may only be switched ON by specially trained personnel.

Switching radiation ON

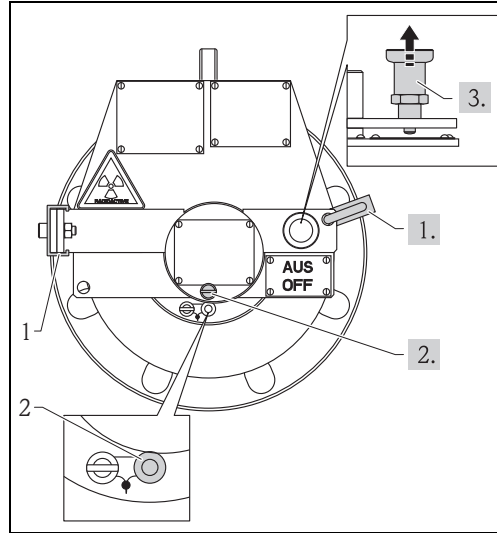

1. Remove padlock.
2. Loosen setscrew (optional).
3. Pull out locking bolt.

⚠ WARNING

Do not remove the safety bracket (1). Do not press the locking pin (2). If the insert is rotated over the locking pin, the source holder can be removed from the source container.

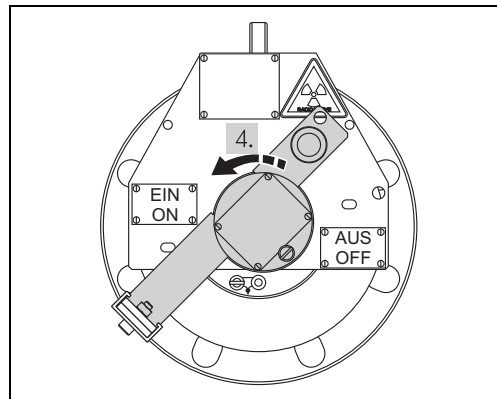

4. Turn rotary bracket 180° counterclockwise.

NOTICE

The current switching state is marked by the visible sign ("EIN - ON" or "AUS - OFF"). The currently invalid sign is covered by the rotary bracket.

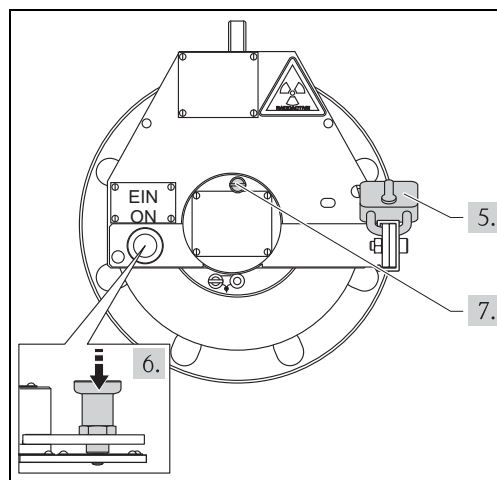

5. Fix the padlock at the provided position.
6. Let the locking bolt snap into place in the "EIN - ON" position. Check for correct locking.
7. Tighten setscrew (optional).

Switching radiation OFF

In order to switch the radiation OFF, perform the above steps in reverse order.

FQG61/FQG62;
Feature 020, Option model C

Safety instructions for switching on the radiation

- Before switching ON the radiation it is necessary to ensure that no personnel are within the area of the radiation (or, indeed, inside the vessel).
- The radiation beam may only be switched ON by specially trained personnel.

Switching radiation ON

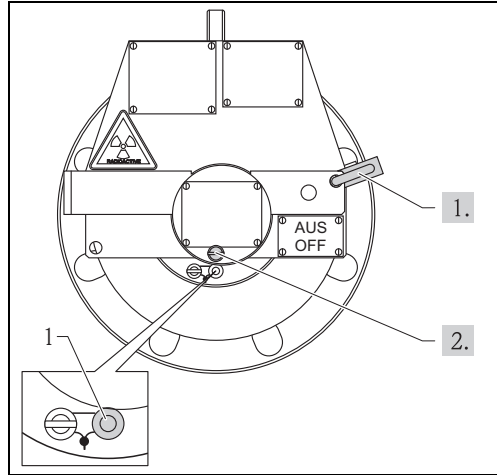

1. Remove padlock.
2. Loosen setscrew (optional).

⚠ WARNING

Do not press the locking pin (1). If the insert is rotated over the locking pin, the source holder can be removed from the source container.

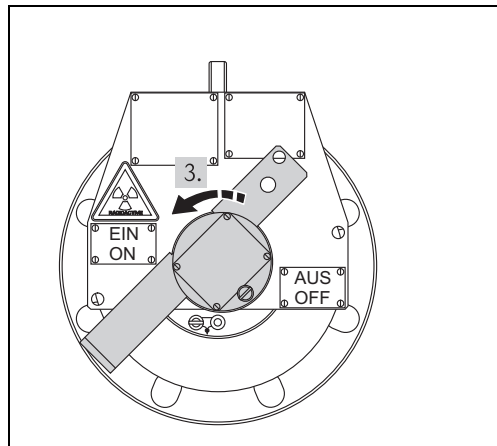

3. Turn rotary bracket 180° counterclockwise.

NOTICE

The current switching state is marked by the visible sign ("EIN - ON" or "AUS - OFF"). The currently invalid sign is covered by the rotary bracket.

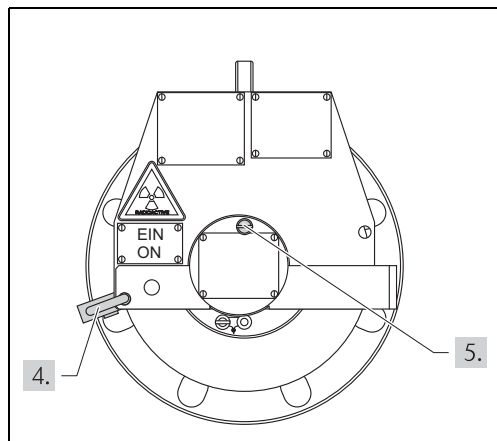

4. Secure the "ON" switching state with the padlock at the provided position.
5. Tighten setscrew (optional).

Switching radiation OFF

In order to switch the radiation OFF, perform the above steps in reverse order.

FQG61/FQG62;
Feature 020, Option model D

Safety instructions for switching on the radiation

- Before switching ON the radiation it is necessary to ensure that no personnel are within the area of the radiation (or, indeed, inside the vessel).
- The radiation beam may only be switched ON by specially trained personnel.

Switching radiation ON

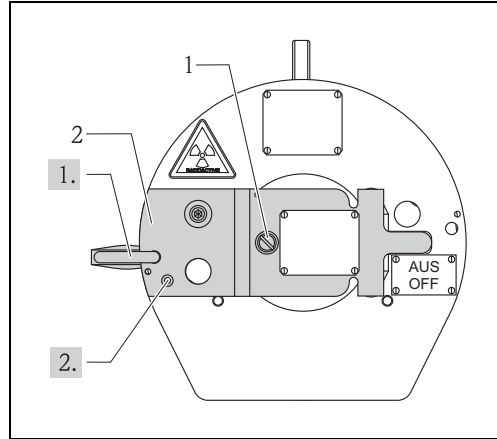

1. Remove padlock.
2. Loosen setscrew (optional).

⚠ WARNING

Do not loosen the screw (1) and do not lift the rotary bracket (2). If the bracket is lifted, the source holder can be removed from the source container.

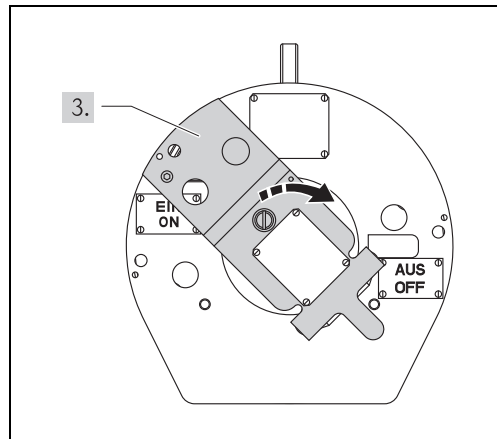

3. Turn rotary bracket (3) 180° clockwise.

NOTICE

The current switching state is marked by the visible sign ("EIN - ON" or "AUS - OFF"). The currently invalid sign is covered by the rotary bracket.

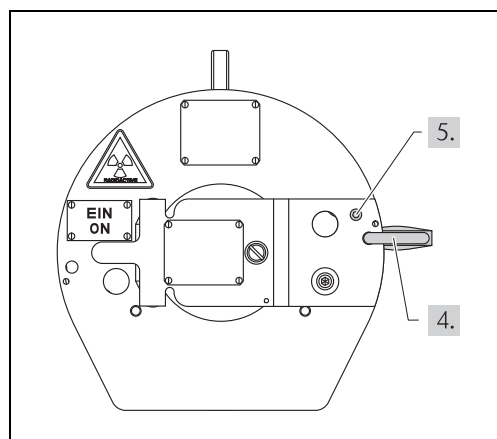

4. Secure the "ON" switching state with the padlock at the provided position.
5. Tighten setscrew (optional).

Switching radiation OFF

In order to switch the radiation OFF, perform the above steps in reverse order.

Maintenance and Inspection

Cleaning

Clean the device in periodical intervals. When doing so, observe the following:

- Clean the device from substances which may have impact on safety functions.
- Keep labels in legible condition.
- Clean the adhesive labels and - for the versions with pneumatic actuator - the terminal box only wet with water.

⚠ CAUTION

When cleaning the device, the safety instructions (→  3) have to be observed.

Maintenance and Inspection

In designated use, operated under the specified ambient and operating conditions, no maintenance of the device is required.

Within the framework of routine inspections of the plant the following checks are recommended:

- visual check regarding corrosion of housing, weld seams, outer parts of source insert and lock(s), toothed lock washers and the reference O-ring
- check of the movability of the source holder (on/off function)
- visual check of the readability of the labels and the condition of the warning symbols
- check of the stability and position of the source holder

⚠ CAUTION

What to do in case of incorrect function

- ▶ If there is any doubt about correct function or proper condition of the device, immediately contact the responsible radiation safety officer for advice.
- ▶ Non-routine repair or maintenance must be performed by the gauge manufacturer or distributor or - in the USA - by a person specially authorized by NRC or an Agreement State.

Measures in case of corrosion

If considerable corrosion is visible at the housing, measure the radiation level around the device. If values occur exceeding the normal operation level, cordon off the area and contact the responsible radiation safety officer for instructions immediately.

⚠ CAUTION

In every case corroded devices and toothed lock washers should be exchanged as soon as possible. Source containers with corroded interlocks or source holder require immediate exchange.

NOTICE

The reference O-ring is intended to be used to check for damage due to influence of aggressive media. From the condition of the reference O-ring, conclusions can be drawn on the potential condition of the sealings inside the source container.

Routine test of the shutter mechanism**Manually operated radiation source containers**

1. Loosen the locking bolt (FQG61/FQG62; Feature 020, Option model B) or remove the padlock (if present) as described in the chapter "Operation".
2. Move the sourceholder several times from ON to OFF or from OFF to ON position as described in the chapter "Operation":
 - If the source holder is not movable from ON to OFF position, follow the instructions in section "Emergency Procedure" (→ 38).
 - If the source holder is rough-running or indicating potentially malfunction, secure the source holder in the OFF position and contact the responsible radiation safety officer for further instructions.
 - In case of corrosion, follow the instructions in section "Inspection (Measures in case of corrosion)".

Source containers with pneumatic actuator

1. Remove the padlock ("Commissioning", → 30).
2. Switch the source holder from the OFF to the ON position by pressurization. The source holder shall move uninterrupted to the ON position.

▲ WARNING

Do not touch the indicating window of the indication plate.

3. Reduce pressure below 2,5 bar (36.25 lbs). The source holder shall move back to the OFF position:
 - If the source holder is rough-running or indicating potentially malfunction, secure the source holder in the OFF position and contact the responsible radiation safety officer for further instructions.
 - If the source holder is not movable from ON to OFF position, follow the instructions in the section "Emergency Procedure".
 - In case of corrosion follow the instructions in the section "Inspection (Measures in case of corrosion)".

Routine leak test procedure

The capsule enclosing the radiation source must be checked for leaks at regular intervals. Leak tests shall be performed according to the interval specified by the authority or handling authorization.

NOTICE**Leak test**

Leak tests are not only required as routine checkup but also whenever an incident occurs that may damage the sealed source or the shielding. In such a case the leak test procedure shall be defined by the responsible radiation safety officer observing the applicable regulations and considering the source container and all involved parts of the process vessel. The leak test shall be conducted as soon as possible after the incident. The leak test procedure described below is intended for the following situations:

- ▶ As routine leak test procedure during continuous operation
- ▶ As routine leak test procedure during continuous storage of the radiation source container
- ▶ When placing back the radiation source container into operation after storage

Leak test procedure

Leak tests shall be performed by a person or an organization authorized to provide leak test services or using a leak test kit supplied by an organization authorized to provide leak test kits. Leak test kits shall be used according to its supplier's instructions. Records of the leak test results shall be maintained. Perform following procedure unless otherwise instructed:

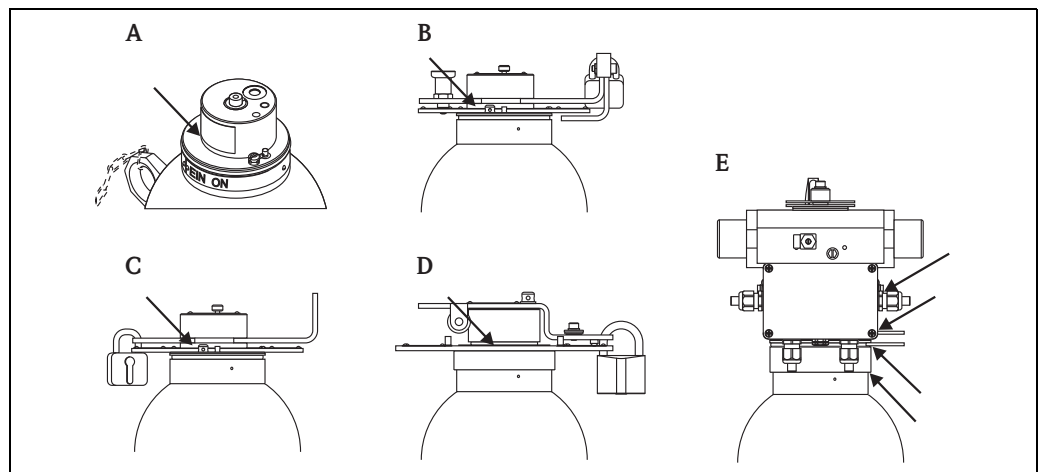

- A FQG61/FQG62; Feature 020, Option model A
 B FQG61/FQG62; Feature 020, Option model B
 C FQG61/FQG62; Feature 020, Option model C
 D FQG61/FQG62; Feature 020, Option model D
 E FQG61/FQG62; Feature 020, Option model K, L, M or N

1. Wipe at least at the following positions:
 - FQG61/FQG62; Feature 020, Option model A, B, C, D:
Along the gap between the source holder and the housing
 - FQG61/FQG62; Feature 020, Option model K, L, M, N:
Along the thread of the proximity switches and the three annular gaps of the cylinder housing.

This may be conducted when the source holder is in ON or OFF position at manually operated types. At types with pneumatic actuator, secure the OFF position with the padlock before conducting the leak test.

2. Have the samples analyzed by an authorized organization. A source is considered to be leaking if more than 185 Bq (5 nCi) is detected on a leak test sample.

NOTICE

This limit value is valid for the US. National regulations may define other limits.

In case of an indeed leaking source:

- Contact the responsible radiation safety officer for instructions
- Take appropriate measures to control a potential spread of radioactive contamination from the source. Secure the source.
- Notify the authority of the fact that a leaking source has been detected.

Emergency procedure

Objective and overview

This emergency procedure shall be put into effect immediately to secure an area in the interests of protecting personnel where an exposed source is known, or suspected, to exist. Such an emergency exists when a radioisotope is exposed either by it becoming separated from the source container or a source holder cannot be put into OFF position. This procedure will safeguard the personnel until the responsible radiation safety officer can attend site and advise on corrective action. The custodian of the radioactive source (the customer's designated "authorized person") is responsible for observing this procedure.

1. Determine the unsafe area by on-site measurement.
2. Cordon off the concerned area by yellow tape or rope and post international radiation warning signs.

The radiation source container can not be switched to the "OFF" position

In this case the radiation source container must be unbolted from its mounting position. Point the emission channel towards a very thick wall (e.g. steel or lead) or mount a blind flange in front of the emission channel. Personnel should at all times be behind the source housing, not in front of the emission channel (flange of the FQG61/FQG62). The lifting eye on the housing should facilitate safe handling.

The radiation source has escaped from the source container

In this case, the radiation source must be placed at a safe location or additional shielding must be applied.

The source should only be handled via pliers or tongs and held as far away from the body as possible. The time needed for the transport should be estimated and minimized by rehearsal without radiation source prior to execution.

Notification to authority

1. Make necessary notifications to local authorities within 24 h.
2. After thorough assessment of the situation, the responsible radiation safety officer, in conjunction with local authorities, shall agree a remedy to the specific problem.

NOTICE

National regulations may require other procedures and reporting obligations.

Procedures after termination of the application

Internal measures

As soon as a radiometric measuring device is no longer required, the radiation source on the source container must be switched off. The source container shall be removed in accordance with all relevant regulations and saved in a lockable room having no through traffic. The responsible authorities shall be informed of these measures. The access to the storage room shall be measured out and signed. The radiation safety officer is responsible for protecting against theft. The radiation source in the source container must not be scrapped with the other parts of the plant. It should be returned as quickly as possible.

⚠ CAUTION

Removal of the source container may only be carried out by supervised personnel, who have been specially trained in radiation procedures according to local regulations or handling approval. Ensure that the contents of the handling approval is valid. Local conditions are to be observed. All work must be carried out as quickly as possible and from a distance as large as possible (shielding!). Safety procedures must also be carried out to protect personnel from all possible risks. The disassembly of the source container can only be executed during OFF position. Make sure, the OFF position is secured with a padlock.

Return

Federal Republic of Germany

Contact your Endress+Hauser Sales Centre to organise the return of the radiation source for inspection with a view to reuse or recycling by Endress+Hauser.

Other countries

Contact your Endress+Hauser Sales Centre or the appropriate authority to find a way of returning the radiation source nationally. If return is not possible domestically, the further procedure must be agreed with the sales centre concerned. The destination airport for potential returns is Frankfurt, Germany.

Conditions

The following conditions must be met before returning the material:

- An inspection certificate no more than three months old confirming the leak-tightness of the radiation source must be in the possession of Endress+Hauser (wipe test certificate).
- The serial number of the source capsule, type of radiation source (^{60}Co or ^{137}Cs), activity and model of radiation source must be specified. This data may be found in the documents supplied with the radiation source.
- The material must be returned in type-tested type-A packaging (IATA rules) (see TI00439F/00/EN).

NOTICE

The type-A-labelling at the radiation container itself is invalid for a return of the device.

Ordering information

Ordering information

Detailed ordering information is available from the following sources:

- In the Product Configuration on the Endress+Hauser website: www.endress.com → Select country → Instruments → Select device → Product page function: Configure this product
- From your Endress+Hauser Sales Center: www.endress.com/worldwide



Product Configurator - the tool for individual product configuration

- Up-to-the-minute configuration data
- Depending on the device: Direct input of measuring point-specific information such as measuring range or operating language
- Automatic verification of exclusion criteria
- Automatic creation of the order code and its breakdown in PDF or Excel output format
- Ability to order directly in the Endress+Hauser Online Shop

Scope of delivery

- Radiation source container FQG61 or FQG62
- Radiation source (built in)
- Radiation warning sign
- Technical Information/Operating Instructions: TI00435F/00/EN
- Special documentation: SD00297F/00/EN (if unloaded)
- Safety Instructions: SD00292F/00/EN (for delivery to Kanada)
- Safety Instructions: SD00293F/00/EN (for delivery to the USA)

Delivery

Germany

We can only ship radioactive sources once we have received a copy of the handling permit. We are more than happy to assist in procuring the necessary documents. Please contact our local sales centre. For safety reasons and to save costs, we generally supply the source container loaded, i.e. with the radiation source installed. If the user requires the source container be delivered first and if the source must be delivered subsequently, transportation drums are used for shipping.

Other countries

We can only ship radioactive sources once we have received a copy of the import licence. Endress+Hauser is more than happy to assist in procuring the necessary documents. Please contact your local sales centre. Please contact your local sales centre. Radioactive sources must be installed in the source container for delivery abroad.

The source container is delivered in the OFF position, secured with a lock. The transport of loaded source containers is conducted by a company commissioned by Endress+Hauser and officially certified for executing this type of job. Transportation shall take place in a Type "A" package which complies to the regulations of the European Agreement on the International Transportation of Hazardous Substances on Roads (ADR and DGR/IATA).

Accessories

Clamping device FHG61

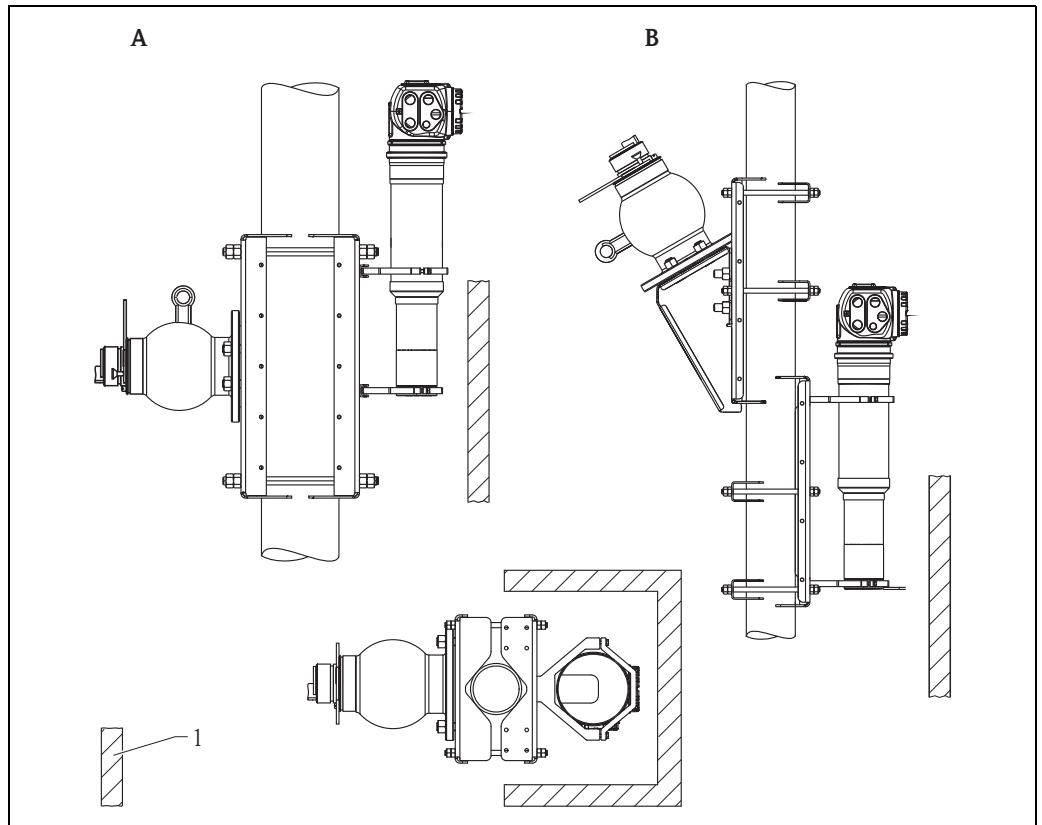

- A Radial beam
 B Diagonal beam 30°
 1 Additional shielding is required

Ordering information

Detailed ordering information is available from the following sources:

- In the Product Configuration on the Endress+Hauser website: www.endress.com → Select country → Instruments → Select device → Product page function: Configure this product
- From your Endress+Hauser Sales Center: www.endress.com/worldwide



Product Configurator - the tool for individual product configuration

- Up-to-the-minute configuration data
- Depending on the device: Direct input of measuring point-specific information such as measuring range or operating language
- Automatic verification of exclusion criteria
- Automatic creation of the order code and its breakdown in PDF or Excel output format
- Ability to order directly in the Endress+Hauser Online Shop



For details refer to SD01221F/00/EN.

Measuring path FHG62

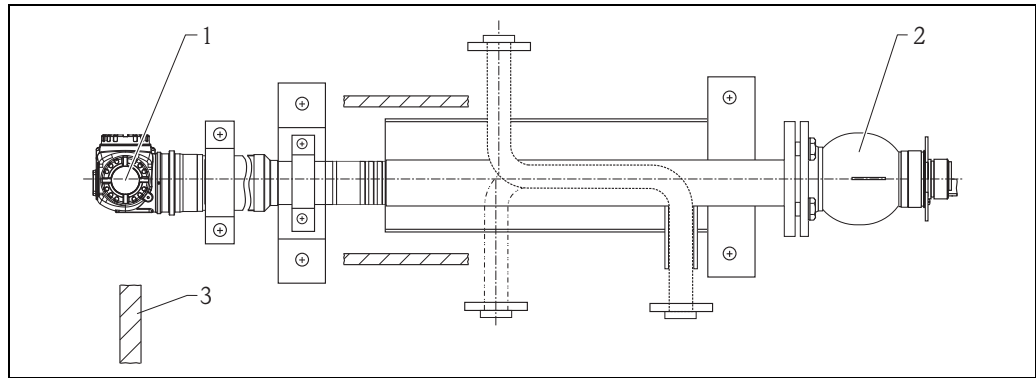

- 1 FMG60
 2 FQG61/FQG62
 3 Additional shielding is required

Ordering information

Detailed ordering information is available from the following sources:

- In the Product Configuration on the Endress+Hauser website: www.endress.com → Select country → Instruments → Select device → Product page function: Configure this product
- From your Endress+Hauser Sales Center: www.endress.com/worldwide

**Product Configurator - the tool for individual product configuration**

- Up-to-the-minute configuration data
- Depending on the device: Direct input of measuring point-specific information such as measuring range or operating language
- Automatic verification of exclusion criteria
- Automatic creation of the order code and its breakdown in PDF or Excel output format
- Ability to order directly in the Endress+Hauser Online Shop



For details refer to SD00540F/00/EN.

Associated documentation

Gamma Radiation Source FSG60/FSG61	TI00439F/00/EN <ul style="list-style-type: none">▪ Technical Information for Gamma Radiation Source FSG60/FSG61▪ Returning source container▪ Type A packaging
Source container FQG60, FQG61, FQG62, FQG63	SD00297F/00/EN Instructions for loading and changing the source. Label set
Clamping Device FHG61	SD01221F/00/EN Clamping device FHG61 For rectangular and diagonally irradiated pipes with an diameter 50 to 420 mm (1.97 to 16.5 in)
Measuring Path FHG62	SD00540F/00/EN Measuring path FHG62 for density measurements
Gamma Modulator FHG65 Synchronizer FHG66	TI00423F/00/EN Technical Information for Gamma Modulator FHG65 and Synchronizer FHG66 BA00373F/00/EN Operating Instructions for Gamma Modulator FHG65 and Synchronizer FHG66
Radiation Source Container QG2000	TI00346F/00/EN Technical Information for Radiation Source Container QG2000 BA00223F/00/EN Operating Instructions for Radiation Source Container QG2000
Gammapilot M FMG60	TI00363F/00/EN Technical Information for Gammapilot M FMG60 BA00236F/00/EN Operating Instructions for Gammapilot FMG60 (HART) BA00329F/00/EN Operating Instructions for Gammapilot FMG60 (PROFIBUS PA) BA00330F/00/EN Operating Instructions for Gammapilot FMG60 (FOUNDATION Fieldbus)
Gammapilot FTG20	TI01023F/00/EN Technical Information for Gammapilot FTG20 BA01035F/00/EN Operating Instructions for Gammapilot FTG20

**Supplementary Instruction
Manuals**

SD00292F/00/EN

Supplementary Instruction Manual for Canada

SD00293F/00/EN

Supplementary Instruction Manual for the USA

XA00507F/00/A3

Safety Instructions ATEX II 2 G c IIB T4 X

**Manufacturer Declaration
Radiation Source Container**

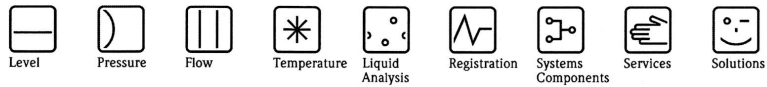

HE-09009b/00

Seite 1 von 1

Page 1 of 1

**Herstellereklärung
Manufacturer Declaration**

Endress+Hauser GmbH+Co. KG, Hauptstraße 1, 79689 Maulburg

erklärt als Hersteller, dass die Strahlenschutzbehälter
declares as manufacturer, that the gamma source containers

FQG61-, FQG62-

den Anforderungen über die internationale Beförderung gefährlicher Güter (ADR/RID, DGR/IATA) an ein Typ A Versandstück entspricht. Die Strahlenschutzbehälter sind für den Transport von umschlossenen radioaktiven Stoffen und von umschlossenen radioaktiven Stoffen in besonderer Form vorgesehen.

conforms to the requirements on international transportation of hazardous materials (ADR/RID, DGR/IATA) for Type A packaging and are intended for the transportation of sealed radioactive materials and sealed special form radioactive materials.

Maulburg, 30.07.2010

Endress+Hauser GmbH+Co. KG

i. V.

(Dr. Arno Götz)

Abteilungsleiter : Produktsicherheit
Head of Department : Product Safety

i. V.

(Hartmut Damm)

Abteilungsleiter : Radiometrische Messtechnik
Head of Department : Radiometric Measurement

Endress+Hauser 
People for Process Automation



www.addresses.endress.com
