

Technical Information

Proline t-mass T 150

Thermal mass flowmeter



The flowmeter for reliable and easy monitoring of liquids

Application

- Measuring principle is characterized by a high operable flow range and direct mass flow measurement
- Dedicated to the monitoring of conductive and nonconductive liquids

Device properties

- Insertion version for nominal diameter DN 40 to 1000 (1½ to 40")
- Sensor in standard or hygienic version
- SIP cleaning possible up to 130 °C (266 °F)
- Device in compact version with DC 24 V power supply
- 4-20 mA HART, pulse/frequency/switch output
- Compact and robust transmitter

Your benefits

- High process safety – high repeatability and linearity due to integrated temperature compensation
- Cost-effective measurement – easy installation, negligible pressure loss and maintenance-free
- Reliable flow trending – multivariable measurement
- Fast and efficient commissioning – guided operating menus
- High plant availability – self-diagnostics and error monitoring
- Automatic recovery of data for servicing







Table of contents

Document information	3	Process	23
Symbols used	3	Medium temperature range	23
Function and system design	4	Process temperature range	23
Measuring principle	4	Pressure-temperature ratings	23
Measuring system	4	Flow limit	26
Input	5	Pressure loss	26
Measured variable	5	System pressure	26
Measuring range	5	Thermal insulation	26
Operable flow range	6	Mechanical construction	27
Input signal	6	Design, dimensions	27
Output	7	Weight	36
Output signal	7	Materials	37
Signal on alarm	7	Process connections	39
Ex connection data	8	Operability	40
Low flow cut off	9	Operating concept	40
Galvanic isolation	9	Local operation	40
Protocol-specific data	9	Remote operation	40
Power supply	10	Certificates and approvals	41
Terminal assignment	10	CE mark	41
Pin assignment of the connector	10	C-Tick symbol	41
Supply voltage	11	Ex approval	42
Power consumption	11	Hygienic compatibility	42
Current consumption	11	Other standards and guidelines	42
Power supply failure	12	Ordering information	42
Electrical connection	12	Application packages	43
Potential equalization	14	Accessories	43
Terminals	14	Device-specific accessories	43
Cable entries	14	Communication-specific accessories	44
Cable specification	14	Service-specific accessories	45
Performance characteristics	14	System components	45
Reference operating conditions	14	Documentation	45
Maximum measured error	14	Standard documentation	45
Repeatability	15	Supplementary device-dependent documentation	45
Response time	15	Registered trademarks	45
Influence of medium temperature	15		
Installation	16		
Mounting location	16		
Orientation	16		
Pipes	16		
Insertion depth	17		
Installation conditions for nipples	19		
Alignment with flow direction	20		
Inlet and outlet runs	20		
Environment	21		
Ambient temperature range	21		
Storage temperature	22		
Degree of protection	22		
Shock resistance	22		
Vibration resistance	22		
Electromagnetic compatibility (EMC)	22		







Document information

Symbols used

Electrical symbols



Symbol	Meaning
 A0011197	Direct current A terminal to which DC voltage is applied or through which direct current flows.
 A0011198	Alternating current A terminal to which alternating voltage is applied or through which alternating current flows.
 A0017381	Direct current and alternating current <ul style="list-style-type: none"> ▪ A terminal to which alternating voltage or DC voltage is applied. ▪ A terminal through which alternating current or direct current flows.
 A0011200	Ground connection A grounded terminal which, as far as the operator is concerned, is grounded via a grounding system.
 A0011199	Protective ground connection A terminal which must be connected to ground prior to establishing any other connections.
 A0011201	Equipotential connection A connection that has to be connected to the plant grounding system: This may be a potential equalization line or a star grounding system depending on national or company codes of practice.

Symbols for certain types of information

Symbol	Meaning
 A0011182	Allowed Indicates procedures, processes or actions that are allowed.
 A0011183	Preferred Indicates procedures, processes or actions that are preferred.
 A0011184	Forbidden Indicates procedures, processes or actions that are forbidden.
 A0011193	Tip Indicates additional information.
 A0011194	Reference to documentation Refers to the corresponding device documentation.
 A0011195	Reference to page Refers to the corresponding page number.
 A0011196	Reference to graphic Refers to the corresponding graphic number and page number.

Symbols in graphics

Symbol	Meaning
1, 2, 3, ...	Item numbers
1., 2., 3., ...	Series of steps
A, B, C, ...	Views
A-A, B-B, C-C, ...	Sections
 A0013441	Flow direction

Symbol	Meaning
 A0011187	Hazardous area Indicates a hazardous area.
 A0011188	Safe area (non-hazardous area) Indicates a non-hazardous area.

Function and system design

Measuring principle

The thermal measuring principle is based on the cooling of a heated resistance thermometer (PT100), from which heat is extracted by the passing medium - gas or liquid. The medium passes two PT100 resistance thermometers in the measurement section. One of these is used in the conventional way as a temperature sensor, while the other serves as a heating element. The temperature sensor monitors and records the effective process temperature while the heated resistance thermometer is kept at a constant differential temperature (compared to the measured process temperature) by controlling the electrical current used by the heating element. The greater the mass flow passing over the heated resistance thermometer, the greater the extent to which cooling takes place and therefore the stronger the current required to maintain a constant differential temperature. This means that the heat current measured is an indicator of the mass flow rate of the medium.

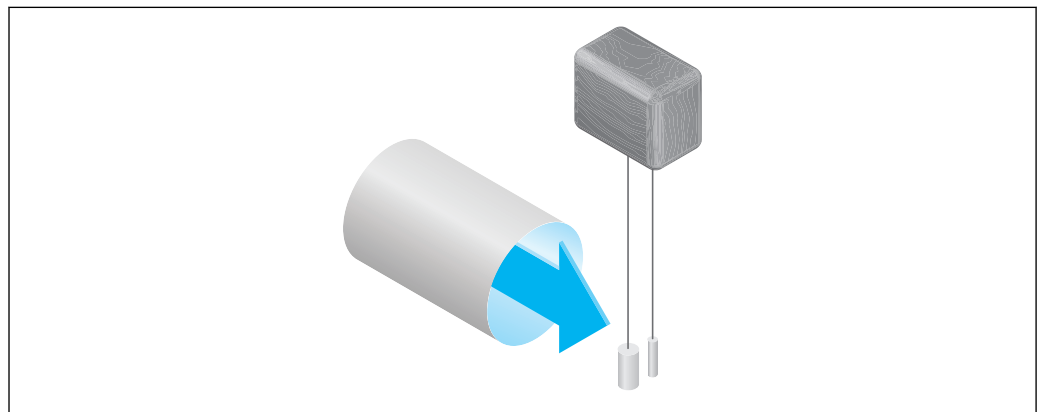

A0016823

Measuring system

The device consists of a transmitter and a sensor.

One device version is available: compact version - transmitter and sensor form a mechanical unit.

Transmitter

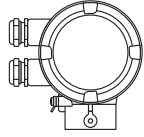
<p>t-mass 150</p>  <p>A0015480</p>	<p>Device versions and materials: Compact version, aluminum coated: Coated aluminum AISi10Mg</p> <p>Configuration:</p> <ul style="list-style-type: none"> ▪ Via four-line local display with key operation and guided menu ("Make-it-run" wizards) for applications ▪ Via operating tools (e.g. FieldCare) <p>Other special features: May also be ordered without local display</p>
--	---

Sensor

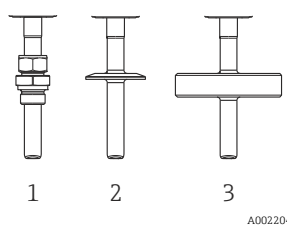
<p>t-mass T</p>  <p>1: <i>Standard version</i></p> <p>2: <i>Hygienic version with Tri-Clamp</i></p> <p>3: <i>Hygienic version with DIN 11851 conical coupling with union nut (sanitary connection)/DIN 11864-1 Form A aseptic liner with union nut</i></p>	<p>Insertion version: Nominal diameter range: DN 40 to 1000 (1½ to 40")</p> <p>Sensor lengths:</p> <ul style="list-style-type: none"> ■ Standard version <ul style="list-style-type: none"> - 110 mm (4") - 330 mm (13") ■ Hygienic version: <ul style="list-style-type: none"> 30 to 85 mm (1.2 to 3.3") <p>Materials:</p> <ul style="list-style-type: none"> ■ Transducer: <ul style="list-style-type: none"> - Standard version: stainless steel, 1.4404 (316, 316L) or Hastelloy AC22, 2.4602 (N06022) - Hygienic version: stainless steel, 1.4404 (316/316L), sensor tip made of Hastelloy AC22, 2.4602 (N06022) ■ Process connections: <ul style="list-style-type: none"> - Compression fitting G ¾" A, ¾" NPT: stainless steel, 1.4404 (316L) - Threadolet: stainless steel, 1.4404 (316L) or Hastelloy AC22, 2.4602 (N06022) - Union nut for compression fitting and threadolet: 1.4571 similar to 316Ti - Clamping ferrules: PEEK 450G or stainless steel, 1.4404 (316L) or Hastelloy AC22, 2.4602 (N06022) - Sealing ring EPDM/HNBR: stainless steel, 1.4404 similar to 316L (outer ring) - 1-½" Tri-Clamp, 2" Tri-Clamp, ISO 2852/DIN 32676; conical coupling, DN40 DIN 11851, DN50 DIN 11851; aseptic liner, DN40 DIN 11864-1A, DN50 DIN 11864-1A: stainless steel, 1.4404 (316L) ■ Union nut for conical coupling and aseptic liner: stainless steel, 1.4301 similar to 304
--	--

Input

Measured variable

Direct measured variables

- Mass flow
- Medium temperature

Calculated measured variables

Volume flow

Measuring range

The available measuring range depends on the size of the pipe.



The following tables list the ranges available for water.

Order code for "Calibration flow", option G (not verified)

Specified measuring range up to 100 % (→ 14)

SI units for insertion version

DN [mm]	[kg/h]		[l/h]	
	min.	max.	min.	max.
40	226	22 600	226	22 600
50	352	35 200	352	35 200
65	596	59 600	596	59 600
80	902	90 200	902	90 200
100	1 410	141 000	1 410	141 000

DN	[kg/h]		[l/h]	
[mm]	min.	max.	min.	max.
150	3 170	317 000	3 170	317 000
200	5 640	564 000	5 640	564 000
400	22 600	2 260 000	22 600	2 260 000
600	50 700	5 070 000	50 700	5 070 000
800	90 200	9 020 000	90 200	9 020 000
1000	141 000	14 100 000 ¹⁾	141 000	14 100 000 ¹⁾

1) Full scale value calculated with 5 m/s, a density of 1000 kg/m³ and corresponding cross-section.

US units for insertion version

DN	[lb/h]		[gal/h]	
[in]	min.	max.	min.	max.
1½	497	49 700	60	6 000
2	777	77 700	93	9 300
2½	1310	131 000	158	15 800
3	1990	199 000	239	23 900
4	3 110	311 000	373	37 300
6	6 990	699 000	840	84 000
8	12 400	1 240 000	1 500	150 000
16	49 700	4 970 000	6 000	600 000
24	112 000	11 200 000	13 400	1 340 000
32	199 000	19 900 000	23 900	2 390 000
40	311 000	31 100 000 ¹⁾	37 300	3 730 000 ¹⁾

1) Full scale value calculated with 16.4 ft/s, a density of 62.42 lb/ft³ and corresponding cross-section.

Operable flow range 100 : 1

Input signal

Status input

Maximum input values	<ul style="list-style-type: none"> ▪ DC 30 V ▪ 6 mA
Response time	Adjustable: 5 to 200 ms
Input signal level	<ul style="list-style-type: none"> ▪ Low signal: DC -3 to +5 V ▪ High signal: DC 15 to 30 V
Assignable functions	<ul style="list-style-type: none"> ▪ Off ▪ Resetting the totalizer ▪ Flow override ▪ CIP/SIP mode

Output

Output signal

Current output

Current output	4-20 mA HART, active
Maximum output values	<ul style="list-style-type: none"> ▪ DC 24 V (open circuit voltage) ▪ 22 mA <p> If in Failure mode parameter the Defined value option is selected: 22.5 mA</p>
Load	0 to 750 Ω
Resolution	16 Bit or 0.38 μA
Damping	Adjustable: 0 to 999 s
Assignable measured variables	<ul style="list-style-type: none"> ▪ Mass flow ▪ Volume flow ▪ Temperature

Pulse/frequency/switch output

Function	Can be set to pulse, frequency or switch output
Version	Passive, open collector
Maximum input values	<ul style="list-style-type: none"> ▪ DC 30 V ▪ 25 mA
Voltage drop	For 25 mA: ≤ DC2 V
Pulse output	
Pulse width	Adjustable: 0.5 to 2 000 ms → pulse rate:0 to 1 000 Pulse/s
Pulse value	Adjustable
Assignable measured variables	<ul style="list-style-type: none"> ▪ Off ▪ Volume flow ▪ Mass flow
Frequency output	
Maximum frequency	Adjustable: 0 to 1 000 Hz
Damping	Adjustable: 0 to 999 s
Pulse/pause ratio	1:1
Assignable measured variables	<ul style="list-style-type: none"> ▪ Off ▪ Volume flow ▪ Mass flow ▪ Temperature
Switch output	
Switching behavior	Binary, conductive or non-conductive
Switching delay	Adjustable: 0 to 100 s
Number of switching cycles	Unlimited
Assignable functions	<ul style="list-style-type: none"> ▪ Off ▪ On ▪ Diagnostic behavior ▪ Limit ▪ Status

Signal on alarm

Depending on the interface, failure information is displayed as follows:

Current output

4-20 mA

Failure mode	Selectable (as per NAMUR recommendation NE 43): <ul style="list-style-type: none"> ▪ Minimum value: 3.6 mA ▪ Maximum value: 22 mA ▪ Defined value: 3.59 to 22.5 mA ▪ Actual value ▪ Last valid value
---------------------	---

HART

Device diagnostics	Device condition can be read out via HART Command 48
---------------------------	--

Pulse/frequency/switch output

Pulse output	
Failure mode	Choose from: <ul style="list-style-type: none"> ▪ Actual value ▪ No pulses
Frequency output	
Failure mode	Choose from: <ul style="list-style-type: none"> ▪ Actual value ▪ Defined value: 0 to 1250 Hz ▪ 0 Hz
Switch output	
Failure mode	Choose from: <ul style="list-style-type: none"> ▪ Current status ▪ Open ▪ Closed

Local display

Plain text display	With information on cause and remedial measures
---------------------------	---



Status signal as per NAMUR recommendation NE 107

Operating tool

- Via digital communication: HART protocol
- Via service interface

Plain text display	With information on cause and remedial measures
---------------------------	---



Additional information on remote operation

Ex connection data**Ex nA type of protection**

Order code for "Output; Input"	Output type	Safety-related values
Option A	4-20mA HART	<ul style="list-style-type: none"> ▪ Galvanically isolated: ▪ Active: 4 to 20 mA ▪ $R_L < 750 \Omega$, $R_L \text{ HART} \geq 250 \Omega$
Option B	4-20mA HART	<ul style="list-style-type: none"> ▪ Galvanically isolated: ▪ Active: 4 to 20 mA ▪ $R_L < 750 \Omega$, $R_L \text{ HART} \geq 250 \Omega$

Order code for "Output; Input"	Output type	Safety-related values
	Pulse/frequency/switch output	<ul style="list-style-type: none"> ▪ Galvanically isolated: ▪ Passive: 30 V DC/25 mA Open collector Maximum frequency value 0 to 1 000 Hz ($f_{\max} = 1250$ Hz)
Option K	Pulse/frequency/switch output	<ul style="list-style-type: none"> ▪ Galvanically isolated: ▪ Passive: 30 V DC/25 mA Open collector Maximum frequency value 0 to 1 000 Hz ($f_{\max} = 1250$ Hz)
Option Q	4-20mA HART	<ul style="list-style-type: none"> ▪ Galvanically isolated: ▪ Active: 4 to 20 mA $R_L < 750 \Omega$, $R_L \text{ HART} \geq 250 \Omega$
	Pulse/frequency/switch output	<ul style="list-style-type: none"> ▪ Galvanically isolated: ▪ Passive: 30 V DC/25 mA Open collector Maximum frequency value 0 to 1 000 Hz ($f_{\max} = 1250$ Hz)
	Status input	Galvanically isolated <ul style="list-style-type: none"> ▪ -3 to +30 VDC ▪ $R_i = 5 \text{ k}\Omega$

Low flow cut off The switch points for low flow cut off are programmable.

Galvanic isolation The following connections are galvanically isolated from each other:

- Outputs
- Power supply

Protocol-specific data

HART

Manufacturer ID	0x11
Device type ID	0x68
HART protocol revision	6.0
Device description files (DTM, DD)	Information and files under: www.endress.com
HART load	Min. 250 Ω
Dynamic variables	The measured variables can be freely assigned to the dynamic variables. <p>Measured variables for PV (primary dynamic variable)</p> <ul style="list-style-type: none"> ▪ Mass flow ▪ Volume flow ▪ Temperature <p>Measured variables for SV, TV, QV (secondary, tertiary and quaternary dynamic variable)</p> <ul style="list-style-type: none"> ▪ Mass flow ▪ Volume flow ▪ Temperature ▪ Totalizer

Power supply

Terminal assignment

Transmitter

Connection version 4-20 mA HART, pulse/frequency/switch output, status input

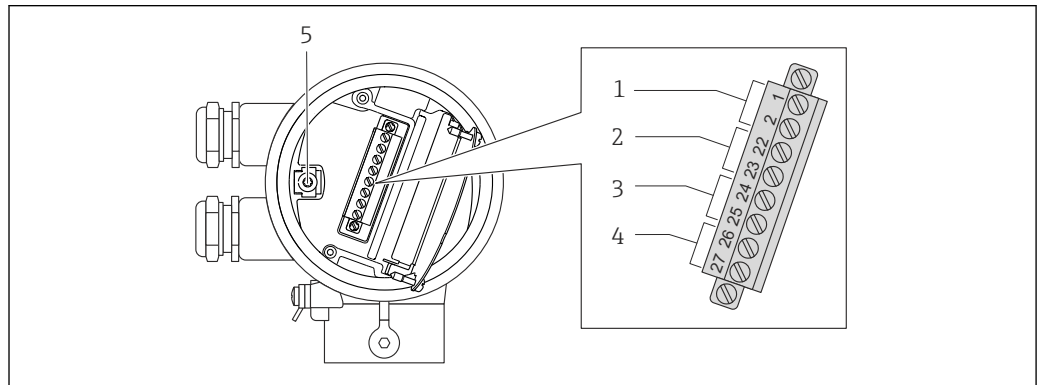

A0017178

- 1 Supply voltage
- 2 Status input
- 3 Signal transmission: pulse/frequency/switch output
- 4 Signal transmission: 4-20 mA HART
- 5 Ground terminal for cable shield

Supply voltage

Order code for "Power supply"	Terminal numbers	
	1 (L+) ¹⁾	2 (L-) ¹⁾
Option D	DC 18 to 30 V	

- 1) Securely tighten the screws of the terminal. Recommended torque: 0.5 Nm.

Signal transmission

Order code for "Output, input"	Terminal numbers					
	Output 1		Output 2		Input	
	26 (+) ¹⁾	27 (-) ¹⁾	24 (+) ¹⁾	25 (-) ¹⁾	22 (+) ¹⁾	23 (-) ¹⁾
Option A	4-20 mA HART (active)		-		-	
Option B	4-20 mA HART (active)		Pulse/frequency/switch output (passive)		-	
Option K	-		Pulse/frequency/switch output (passive)		-	
Option Q	4-20 mA HART (active)		Pulse/frequency/switch output (passive)		Status input	

- 1) Securely tighten the screws of the terminal. Recommended torque: 0.5 Nm.

Pin assignment of the connector



Order code for "Electrical Connection", option Q "2 × plug M12 × 1":
4-20 mA HART, pulse/frequency/switch output (→ 10)

Supply voltage

Supply voltage for all communication types (on the device side)

<p>A0016809</p>	Pin	Assignment	Coding	Plug/socket	
	1	L+	DC24 V	A	Plug
	2	+	Status input		
	3	-	Status input		
	4	L-	DC24 V		
5		Grounding/shielding			

The following is recommended as a socket (5 m cable included): Binder, series 763, part no. 79 3440 35 05

4-20 mA HART with pulse/frequency/switch output

4-20 mA HART with pulse/frequency/switch output (on the device side)

<p>A0016810</p>	Pin	Assignment	Coding	Plug/socket	
	1	+	4-20 mA HART (active)	A	Socket
	2	-	4-20 mA HART (active)		
	3	+	Pulse/frequency/switch output (passive)		
	4	-	Pulse/frequency/switch output (passive)		
5		Grounding/shielding			

The following is recommended as a connector (5 m cable included): Binder, series 763, part no. 79 3439 12 05

Supply voltage

DC 24 V (18 to 30 V)

The power supply circuit must comply with SELV/PELV requirements.

Power consumption

Transmitter

Order code for "Output, input"	Maximum power consumption
Option A: 4-20mA HART	4.0 W
Option B: 4-20mA HART, pulse/frequency/switch output	
Option K: Pulse/frequency/switch output	3.2 W
Option Q: 4-20mA HART, pulse/frequency/switch output, status input	4.0 W

For information on the Ex connection values (→ 8)

Current consumption

Transmitter

Order code for "Output, input"	Maximum current consumption	Maximum switch-on current
Option A: 4-20mA HART	225 mA	< 2.5 A
Option B: 4-20mA HART, pulse/frequency/switch output		

Order code for "Output, input"	Maximum current consumption	Maximum switch-on current
Option K: Pulse/frequency/switch output	180 mA	
Option Q: 4-20mA HART, pulse/frequency/switch output, status input	225 mA	

Power supply failure

- Totalizer stops at the last value measured.
- Configuration is retained in the device memory.
- Error messages (incl. total operated hours) are stored.

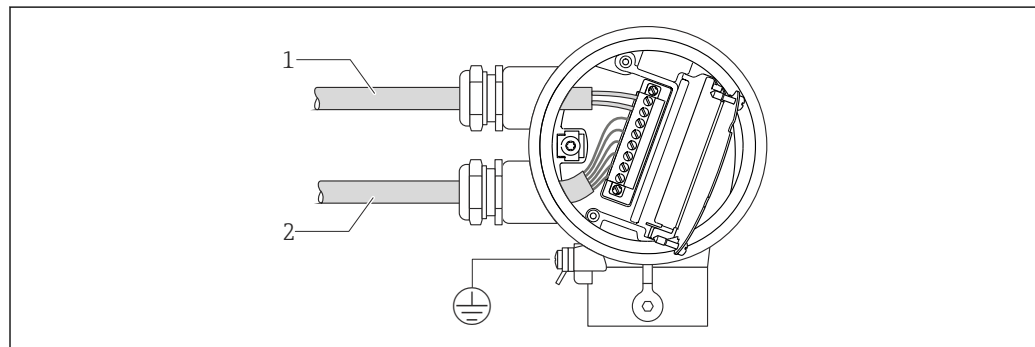
Electrical connection**Connecting the transmitter**

A0017179

- 1 Cable entry for supply voltage
- 2 Cable entry for signal transmission

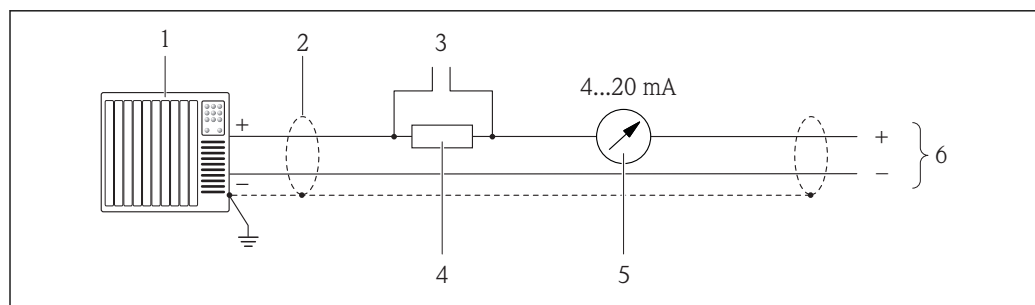
Connection examples*Current output 4-20 mA HART*

A0016800

☞ 1 Connection example for current output, 4-20 mA HART active

- 1 Control system (e.g. PLC)
- 2 Observe cable specifications (→ ☞ 14)
- 3 Connection for Field Communicator 375/475 or Commubox FXA191/195
- 4 Resistor for HART communication ($\geq 250 \Omega$): observe maximum load (→ ☞ 7)
- 5 Analog display unit: observe maximum load (→ ☞ 7)
- 6 Transmitter

HART current output

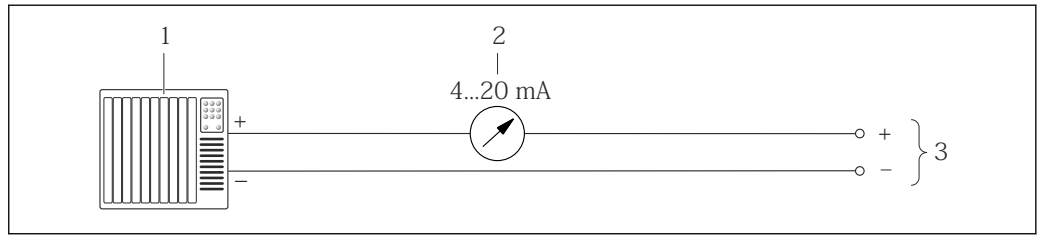

2 Connection example for current output, 4-20 mA active

- 1 Control system (e.g. PLC)
- 2 Analog display unit: observe maximum load (→ 7)
- 3 Transmitter

Pulse/frequency output

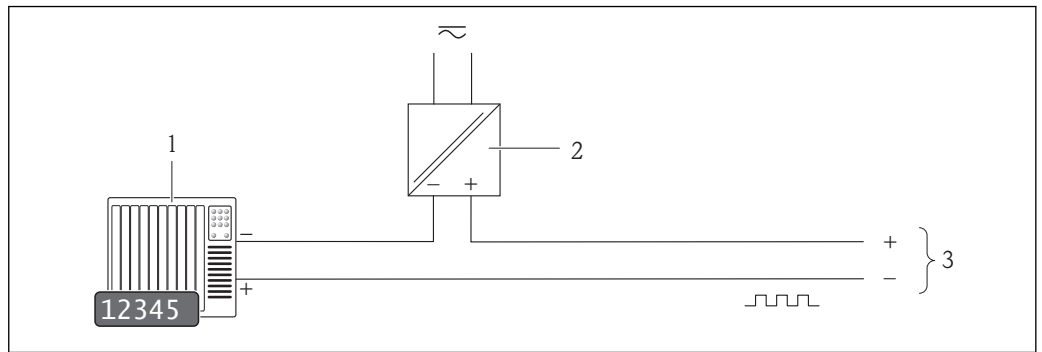

3 Connection example for pulse/frequency output (passive)

- 1 Automation system with pulse/frequency input (e.g. PLC)
- 2 Power supply
- 3 Transmitter: Observe input values (→ 7)

Switch output

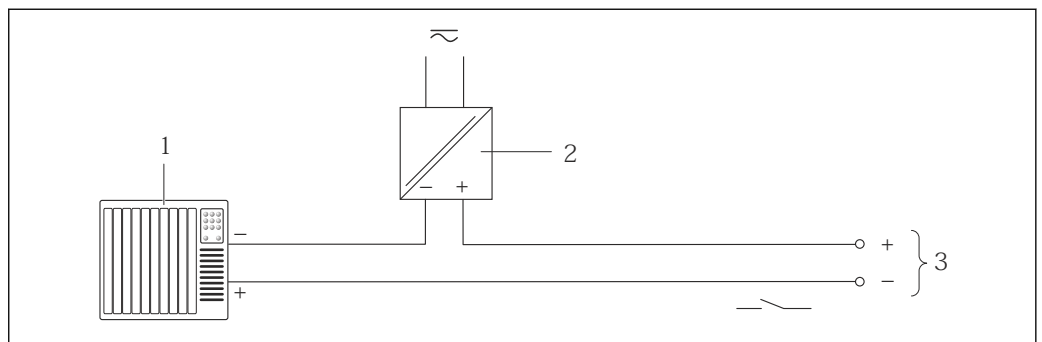

4 Connection example for switch output (passive)

- 1 Automation system with switch input (e.g. PLC)
- 2 Power supply
- 3 Transmitter: Observe input values (→ 7)

Status input

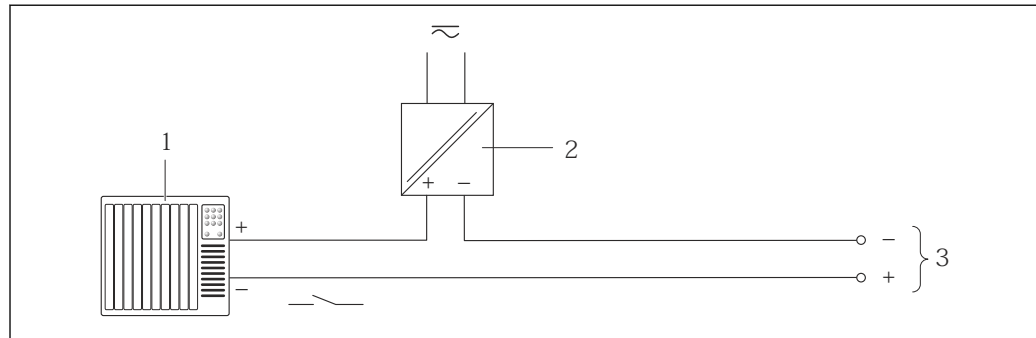

A0017163

5 Connection example for status input

- 1 Automation system with status output (e.g. PLC)
 2 Power supply
 3 Transmitter: Observe input values (→ 5)

Potential equalization No special measures for potential equalization are required.

Terminals Plug-in screw terminals for specified wire cross-sections

Cable entries

- Cable gland: M20 × 1.5 with cable ϕ 6 to 12 mm (0.24 to 0.47 in)
- Thread for cable entry:
 - NPT 1/2"
 - G 1/2"
- 1 × M12 connector (supply voltage, status input), 1 × M12 socket (4 to 20mA, pulse/frequency/switch output)

Cable specification**Wire cross-section**

0.5 to 1.5 mm² (21 to 16 AWG)

Permitted temperature range

- -40 °C (-40 °F) to \geq +80 °C (+176 °F)
- Minimum requirement: cable temperature range \geq ambient temperature +20 K

Power supply cable

Standard installation cable is sufficient.

Signal cable*Current output*

For 4-20 mA HART: Shielded cable recommended. Observe grounding concept of the plant.

Pulse/frequency/switch output, status input

Standard installation cable is sufficient.

Performance characteristics

Reference operating conditions

- Reference fluid: water
- Reference temperature: +25 °C (+77 °F) [\pm 2 °C (\pm 4 °F)]
- Calibration systems traceable to national standards
- Accredited in accordance with ISO/IEC 17025

Maximum measured error o.r. = of reading; o.f.s. = of full scale value

- 
 - The full scale value depends on the nominal diameter of the measuring device.
 - Full scale values of the specified measuring range

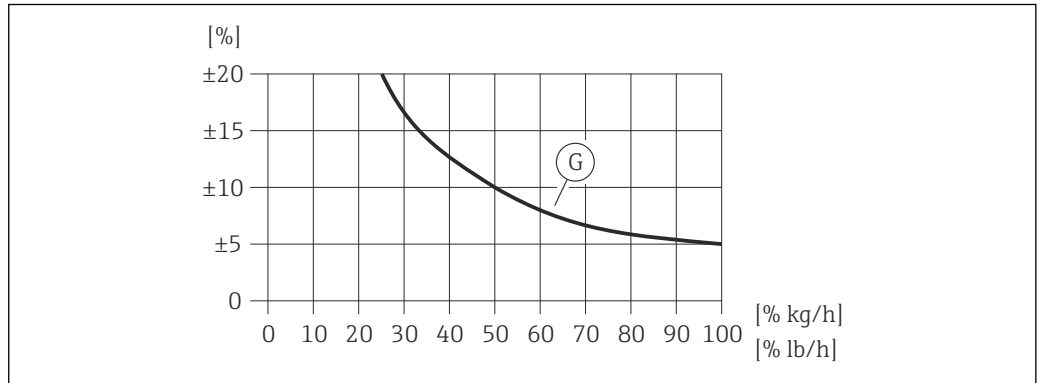

6 Maximum measured error (% mass flow) as % of full scale value. G: Order code for "Calibration flow" (not verified), see the following table

Order code for "Calibration flow" (not verified)	Accuracy	Description
G	Q = 1 to 100 % ±5 %o.f.s. For DN 40 to 150 (1½ to 6") (under reference conditions)	This version is subject to neither a calibration nor a verification of measuring performance. ¹⁾
	For DN > 150 to 1 000 (8 to 40"): Absolute measurement of the flow is not possible in this nominal diameter range.	The device measures the flow trend on a proportional basis. ¹⁾

1) The measured value can be adapted to plant conditions with the installation factor. Onsite adjustment is recommended for unfavorable inlet conditions or for fluids dissimilar to water.

 For detailed information about onsite adjustment, refer to the Operating Instructions for the device on the CD-ROM provided

Accuracy of outputs

Current output

Accuracy	Max. ±0.05 % o.f.s. or ±10 µA
-----------------	-------------------------------

Repeatability	±0.5 % of value for velocities > 0.2 m/s (0.66 ft/s)
Response time	Typically < 3 s for 63 % of a given step change (in both directions)
Influence of medium temperature	±0.2 % o.r./K, deviating from the reference temperature (+25 °C (+77 °F))

Installation

Mounting location

NOTICE

Thermal measuring devices require a fully developed flow profile as a prerequisite for correct flow measurement.

For this reason, please pay attention to the following points and document sections when installing the device:

- ▶ Avoid flow disturbances, as the thermal measuring principle reacts sensitively to them.
- ▶ For mechanical reasons and to protect the pipe, support is recommended for heavy sensors (e.g. when installing a Hot tap extraction assembly).
- ▶ Maintain pre-defined device insertion depth of 8 mm (0.31 in).

Orientation

The direction of the arrow on the sensor body helps you to install the sensor according to the flow direction (direction of medium flow through the piping).

For detailed information on aligning with the flow direction: (→  20)

 Installation is generally not recommended in the event of high vibrations or unstable internal fittings.

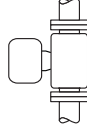
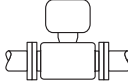
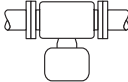
	Orientation	Recommendation
Vertical orientation	 A0017337	✓ ¹⁾
Horizontal orientation, transmitter head up	 A0015589	✓✓
Horizontal orientation, transmitter head down	 A0015590	✓✓

1) Partially filled pipe detection is not possible in this orientation.

 For detailed information about partially filled pipe detection, refer to the Operating Instructions for the device on the CD-ROM provided

Pipes

The measuring device must be professionally installed, and the following points must be observed:

- Piping must be professionally welded.
- Seals must be sized correctly.
- Flanges and seals must be correctly aligned.
- The internal diameter of the pipe must be known. Deviations cause additional measuring uncertainty.
- Following installation, the pipe must be free from dirt and particles in order to avoid damage to the sensors.

Further information → ISO standard 14511



Insertion depth

Standard version

Order code for "Insertion Length", option L5 "110mm 4" and L6 "330mm 13"

NOTICE**Metal clamping ferrules undergo plastic deformation during the initial installation.**

As a result the insertion depth is fixed after initial installation and the clamping ferrules can no longer be replaced.

- ▶ Pay attention to information on preconditions and on determining the insertion depth.
- ▶ Check the insertion depth closely before tightening the clamping ferrules.

Preconditions

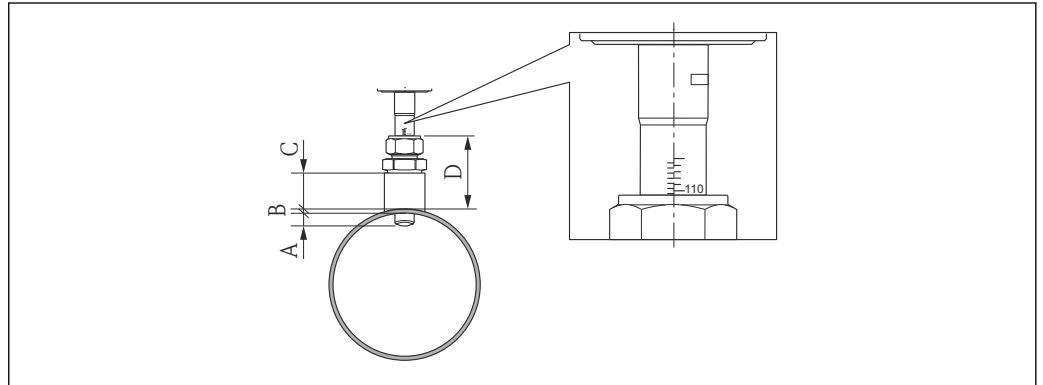

A0022049

- A Fixed insertion depth 8 mm (0.31 in) \pm 2 mm (0.08 in)
 B Pipe wall thickness
 C Mounting boss height
 D Socket height (incl. coupling)

1. Determine pipe wall thickness (B).
2. Measure socket height (D).
 - ↳ **NOTE!** Mounting for the first time: Tighten thread adapter nut of the coupling hand tight.
3. Observe the maximum socket height D.
 - ↳ **NOTE!** The pipe wall thickness (B) and socket height (D) may not exceed the permitted height.
 $B + D$ may not be greater than 102 mm (4.02 in).
4. If a mounting boss is used, pay attention to mounting boss height C.
 - ↳ **NOTE!** The pipe wall thickness (B) and mounting boss height (C) may not exceed the permitted height.
 $B + C$ may not be greater than 53 mm (2.09 in).

Determining the insertion depth before mounting for the first time

- ▶ For all nominal diameters: $8 + B + D - 1$

Controlling the insertion depth after mounting

- ▶ For all nominal diameters: $8 + B + D$

Hygienic version

Order code for "Insertion Length", option LH "Hygienic version"

Factory length

Order code for "Insertion Tube Material; Sensor", option BB "Stainless steel, factory length, 0.8 μ m, mechanically polished" and option BC "Stainless steel, factory length, 0.4 μ m, mechanically polished"

NOTICE**Certain dimensions are required to comply with the factory length.**

- ▶ Pay attention to information in the dimension drawings.

Preconditions

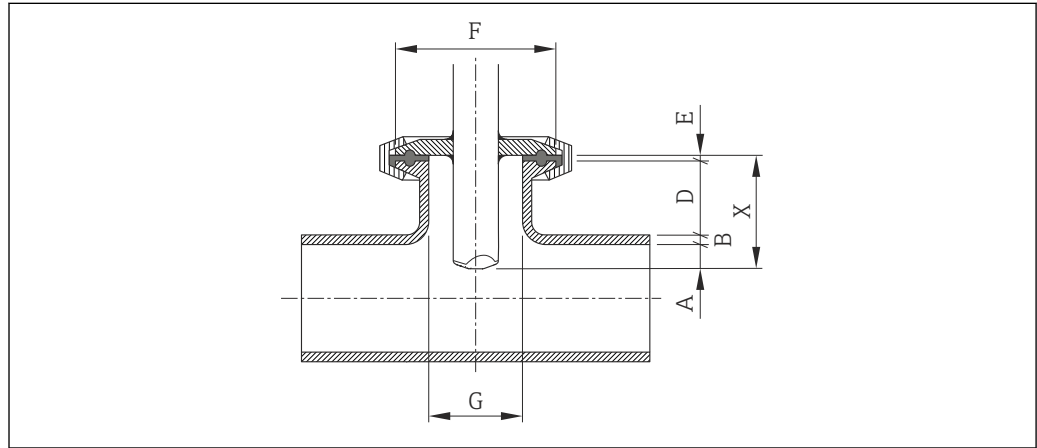

A0022058

- A Fixed insertion depth 8 mm (0.31 in) \pm 2 mm (0.08 in)
 B Pipe wall thickness
 D Socket height
 E Seal thickness
 X Length
 G Socket internal diameter

1. Determine pipe wall thickness (B).
2. If a Tri-Clamp process connection is used, determine seal thickness (E).
 ↳ **NOTE!** The socket internal diameter (G) may not be smaller than 25 mm (0.98 in).
3. If a conical coupling process connection with a self-centering sealing ring is used, determine seal thickness (E).
4. If an aseptic liner or a conical coupling process connection is used, set the seal thickness (E) to equal zero and do not take it into consideration.

Determining the socket height (D)

- ▶ For all nominal diameters: $32 - B - E$

NOTICE

For optimum cleaning it is recommended to:

- ▶ Have a large socket internal diameter (G).
- ▶ Keep the socket height (D) small.

Customized length

Order code for "Material of insertion pipe; sensor", option CB "..... mm customized length, 0.8 μ m, mechanically polished" and option CC "..... mm customized length, 0.4 μ m, mechanically polished"

Order code for "Material of insertion pipe; sensor", option CD "..... inch customized length, 0.8 μ m, mechanically polished" and option CE "..... inch customized length, 0.4 μ m, mechanically polished"

NOTICE

When ordering the customized length, it is necessary to declare the sensor length with the following decimal accuracies:

- ▶ **SI units (mm):** With a minimum of 1 decimal place. Example: 43.3 mm
- ▶ **US units (in):** With a minimum of 2 decimal places. Example: 17.05 in
- ▶ When ordering, a maximum of 3 decimal places can be declared.

NOTICE

Certain dimensions are required for determining the customized length.

- ▶ Pay attention to information in the dimension drawings.

Preconditions

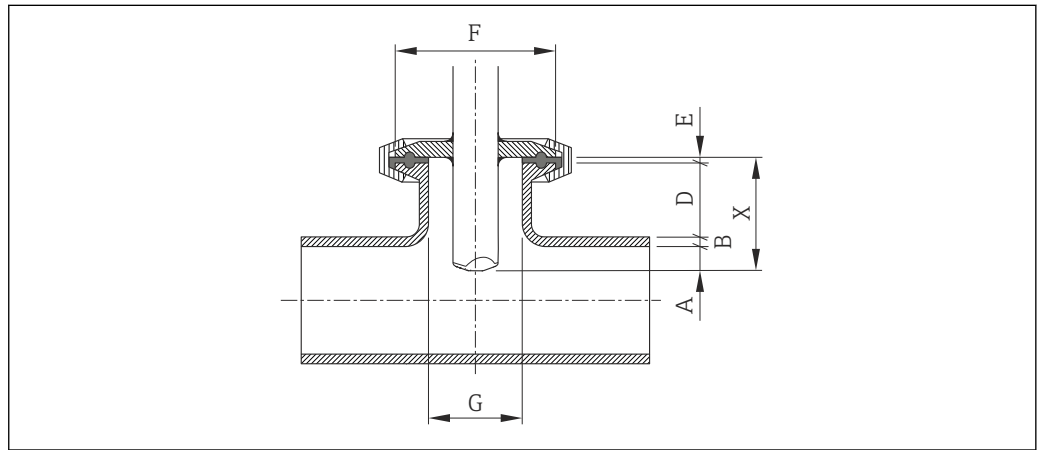

A0022058

- A Fixed insertion depth 8 mm (0.31 in) ±2 mm (0.08 in)
- B Pipe wall thickness
- D Socket height
- E Seal thickness
- X Length
- G Socket internal diameter

1. Determine pipe wall thickness (B).
2. Measure socket height (D).
3. Observe the maximum socket height D.
 - ↳ **NOTE!** The pipe wall thickness (B) and socket height (D) may not exceed the permitted height.
B + D may not be greater than 77 mm (3.03 in).
4. If a Tri-Clamp process connection is used, determine seal thickness (E).
 - ↳ **NOTICE!** The pipe wall thickness (B), socket height (D) and sealing thickness (E) may not exceed the permitted height.
B + D + E may not be greater than 77 mm (3.03 in).
5. If a conical coupling process connection with a self-centering sealing ring is used, determine seal thickness (E).
 - ↳ **NOTE!** The pipe wall thickness (B), socket height (D) and sealing thickness (E) may not exceed the permitted height.
B + D + E may not be greater than 77 mm (3.03 in).
6. If an aseptic liner or a conical coupling process connection is used, set the seal thickness (E) to equal zero and do not take it into consideration.
 - ↳ **NOTE!** The pipe wall thickness (B) and socket height (D) may not exceed the permitted height.
B + D may not be greater than 77 mm (3.03 in).

Determining the customized length

- ▶ For all nominal diameters: $8 + B + D + E$

Installation conditions for nipples

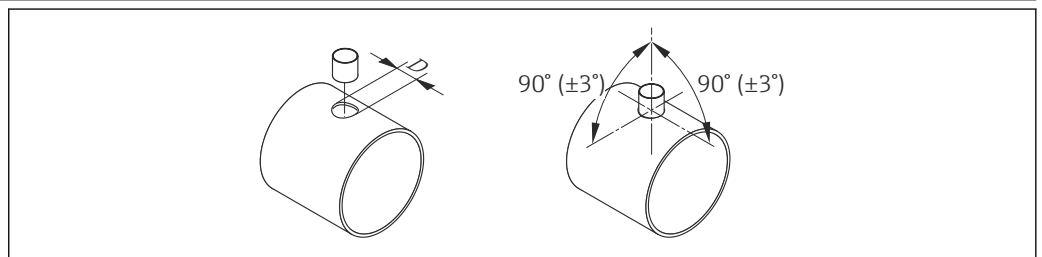

A0011843

- 7 Installation conditions for mounting bosses and threadlets

D = 20.0 mm ± 0.5 mm (0.79 in ± 0.02 in)

- ▶ In the case of weld-in couplings with PEEK clamping ferrules, remove the clamping ferrules before you commence welding to avoid heat damage from the welding process.

Alignment with flow direction

Insertion version

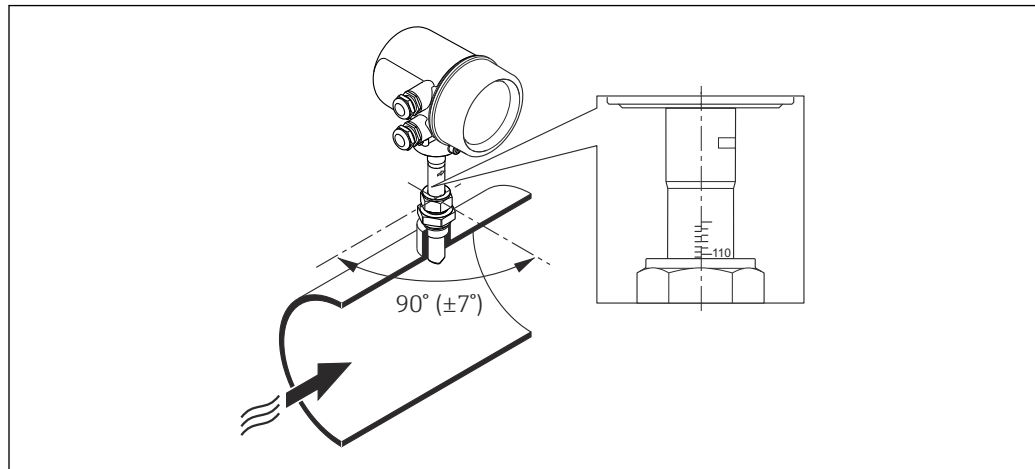

A0022051

1. Check and ensure that the sensor on the pipe is aligned at a 90° angle to the direction of flow (as shown in the graphic).
2. Rotate the sensor so that the arrow marking on the sensor body corresponds to the direction of flow.
3. Align the scale to the pipe axis.

Inlet and outlet runs

NOTICE

The thermal measuring principle is sensitive to disturbed flow conditions.

- ▶ As a general rule, install the measuring device as far away as possible from any flow disturbances. For further information → ISO 14511.
- ▶ If possible, install the sensor upstream from fittings such as valves, T-pieces, elbows etc.
- ▶ To attain the specified level of accuracy of the measuring device, the inlet and outlet runs mentioned below must be maintained at the very minimum.
- ▶ If there are several flow disturbances present, the longest specified inlet run must be maintained.

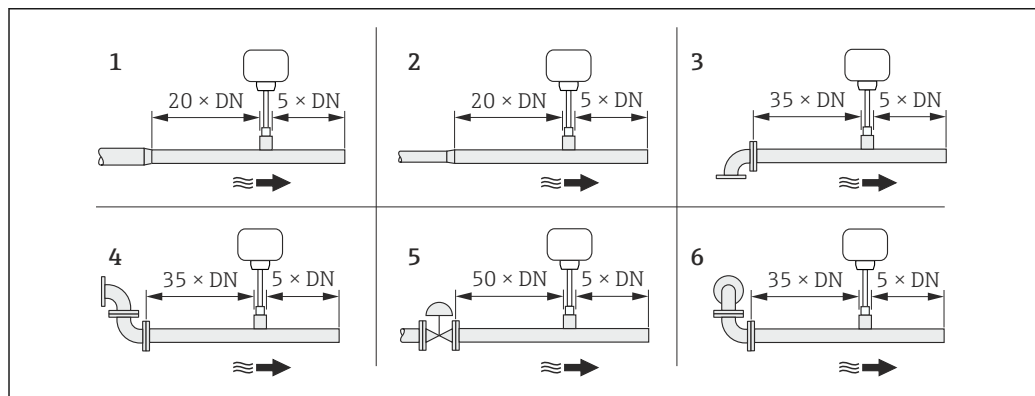

A0022381

- 1 reduction
- 2 expansion
- 3 90° elbow or T-section
- 4 2 × 90° elbow
- 5 Control valve
- 6 2 × 90° elbow 3-dimensional

Environment

Ambient temperature range

Measuring device	-40 to +60 °C (-40 to +140 °F)
Local display	-20 to +60 °C (-4 to +140 °F), the readability of the display may be impaired at temperatures outside the temperature range.

- ▶ If operating outdoors:
Avoid direct sunlight, particularly in warm climatic regions.

 Weather protection covers can be ordered from Endress+Hauser: see "Accessories" section (→  43)

Temperature tables

T_m = fluid temperature, T_a = ambient temperature

The following interdependencies between the permitted ambient and fluid temperatures apply when operating the device in hazardous areas:

Compact version

Order code for "Output", option A "4-20mA HART"

Order code for "Output", option B "4-20mA HART, pulse/frequency/switch output"

Order code for "Output", option K "Pulse/frequency/switch output"

Order code for "Output", option Q "4-20mA HART, pulse/frequency/switch output, status input"

SI units

Sensor	T_a [°C]	T4 [135 °C]	T3 [200 °C]	T2 [300 °C]	T1 [450 °C]
t-mass T	60	100 ¹⁾	100 ¹⁾	100 ¹⁾	100 ¹⁾

- 1) For cleaning purposes (SIP) a temperature of 130 °C is permitted for a period of one hour.

US units

Sensor	T_a [°F]	T4 [275 °F]	T3 [392 °F]	T2 [572 °F]	T1 [842 °F]
t-mass T	140	212 ¹⁾	212 ¹⁾	212 ¹⁾	212 ¹⁾

- 1) For cleaning purposes (SIP) a temperature of 266 °F is permitted for a period of one hour.

Seal, clamping ferrule and sensor

Seal, clamping ferrule and sensor depending on the medium temperature T_m

SI units

Sensor	Seal (G thread only)	T_m [°C]
t-mass T	HNBR	-20 to 100 ¹⁾
	EPDM	-20 to 100

- 1) For cleaning purposes (SIP) a temperature of 130 °C is permitted for a period of one hour.

SI units

Sensor	Clamping ferrule	T _m [°C]
t-mass T	PEEK	-20 to 100 ¹⁾
	1.4404	-20 to 100 ¹⁾
	2.4602	-20 to 100 ¹⁾

1) For cleaning purposes (SIP) a temperature of 130 °C is permitted for a period of one hour.

US units

Sensor	Seal (G thread only)	T _m [°F]
t-mass T	HNBR	-4 to +212 ¹⁾
	EPDM	-4 to +212

1) For cleaning purposes (SIP) a temperature of 266 °F is permitted for a period of one hour.

US units

Sensor	Clamping ferrule	T _m [°F]
t-mass T	PEEK	-4 to +212 ¹⁾
	316L	-4 to +212 ¹⁾
	AC22	-4 to +212 ¹⁾

1) For cleaning purposes (SIP) a temperature of 266 °F is permitted for a period of one hour.

Storage temperature -40 to +80 °C (-40 to +176 °F), preferably at +20 °C (+68 °F)

Degree of protection

Transmitter

- As standard: IP66/67, type 4X enclosure
- When housing is open: IP20, type 1 enclosure
- Display module: IP20, type 1 enclosure

Sensor
IP66/67, type 4X enclosure

Shock resistance As per IEC/EN 60068-2-31

Vibration resistance Tests conducted:

- Vibration, sinusoidal IEC 60068-2-6:
 - 2 to 8.4 Hz with 3.5 mm (0.14 in) peak,
 - 8.4 to 500 Hz with 1 g peak,
 - 20 sweeps/axis,
 - 1 octave/min
- Vibration, broad-band random IEC 60068-2-64:
 - 10 to 200 Hz with 0.003 g²/Hz,
 - 200 to 2 000 Hz with 0.001 g²/Hz (1.54 g rms),
 - 120 minutes/axis
- Shock resistance IEC 60068-2-27:
 - 6 ms30 g,
 - 3 pos. + 3 neg. per axis

Electromagnetic compatibility (EMC)

As per IEC/EN 61326.



For details refer to the Declaration of Conformity.

NAMUR recommendation 21 (NE 21) with restriction: interruption of supply voltage 20 ms not satisfied.

Process

Medium temperature range

Sensor

-20 to +100 °C (-4 to +212 °F)

Seals (G thread only)

- HNBR: -20 to +100 °C (-4 to +212 °F)
- EPDM: -20 to +100 °C (-4 to +212 °F)

 Temperature-dependent density table as per NIST REFPROP Standard Reference (Database 23, Version 9.0)

clamping ferrules

- PEEK: -20 to +100 °C (-4 to +212 °F)
- 1.4404 (316L): -20 to +100 °C (-4 to +212 °F)
- 2.4602 (AC22): -20 to +100 °C (-4 to +212 °F)

Process temperature range

Hygiene applications:

- SIP process: 130 °C (266 °F) for max. one hour
- Temperature gradient: max. 1 000 K/min

Pressure-temperature ratings

The following material load diagrams refer to the sensor and not just the process connection.

Standard version

Coupling with PEEK clamping ferrule

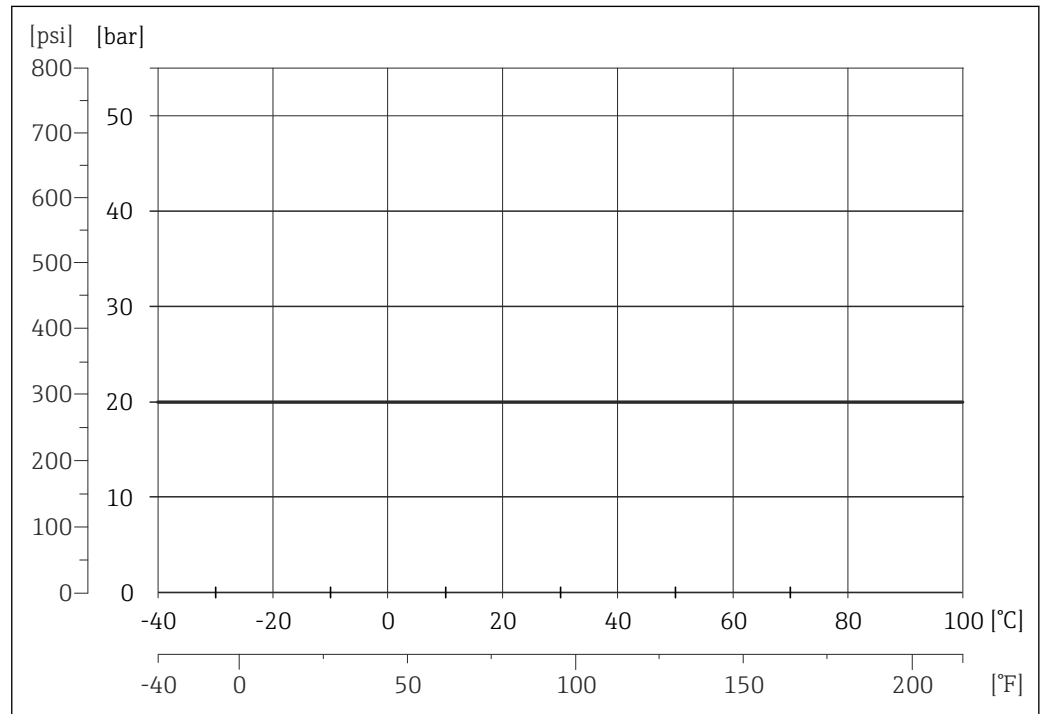

 8 With PEEK 450G material

A0022097-EN

Coupling with metallic clamping ferrule

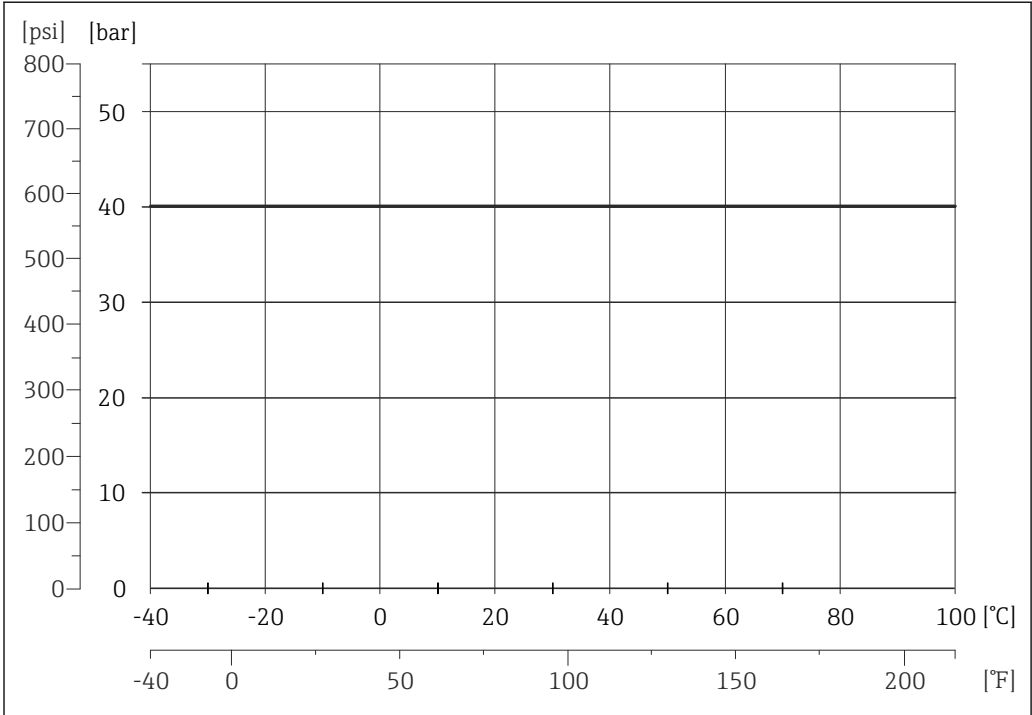

A0022098-EN

9 With stainless steel material, 1.4404 (316L)

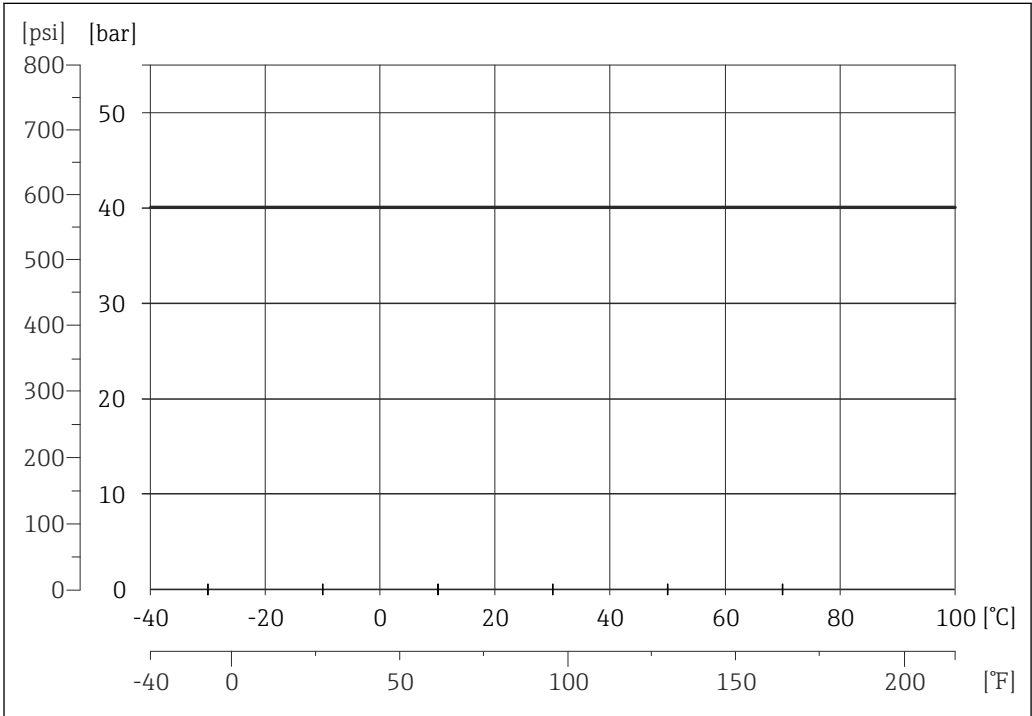

A0022098-EN

10 With Hastelloy AC22, 2.4602 (N06022)

Hygienic version

Tri-Clamp as per ISO 2852/DIN 32676

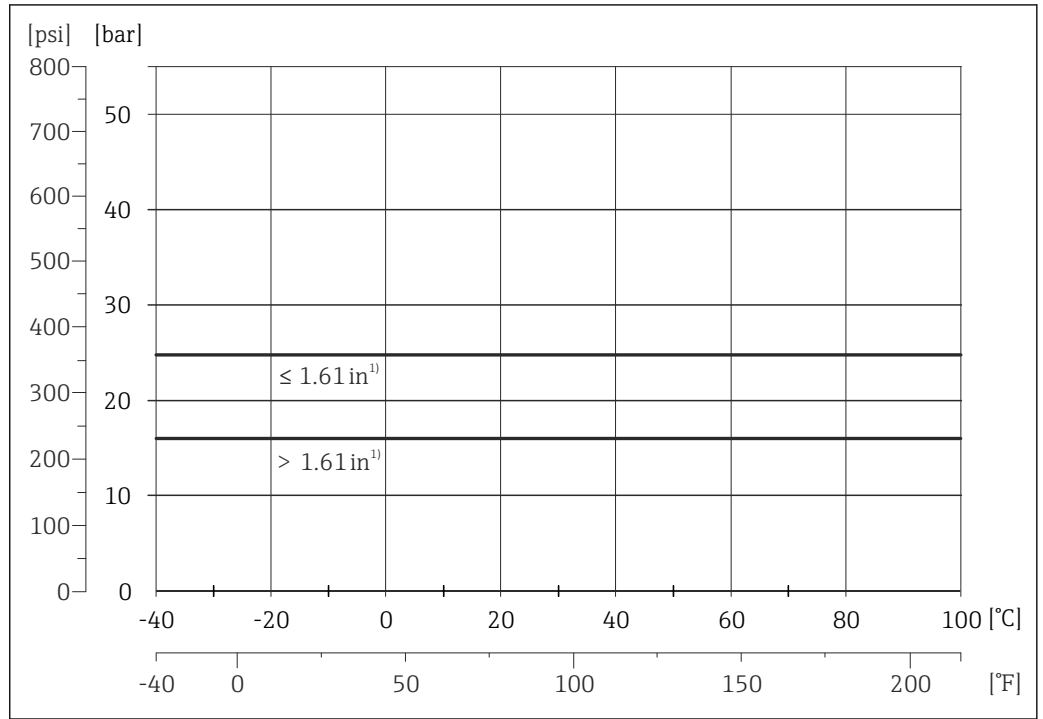

A0022096-EN

11 With stainless steel material, 1.4404 (316L)

1) Socket outer diameter

Conical coupling with union nut (sanitary connection): as per 11851

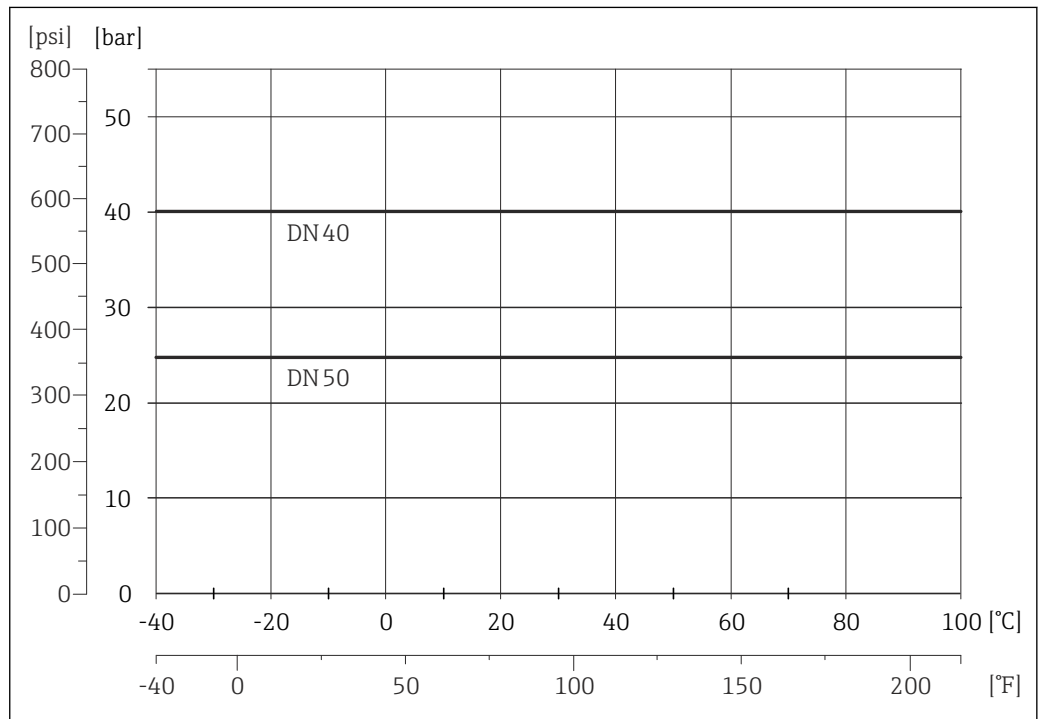

A0022094-EN

12 With stainless steel material, 1.4404 (316L)

Aseptic liner with union nut as per DIN 11864-1 Form A

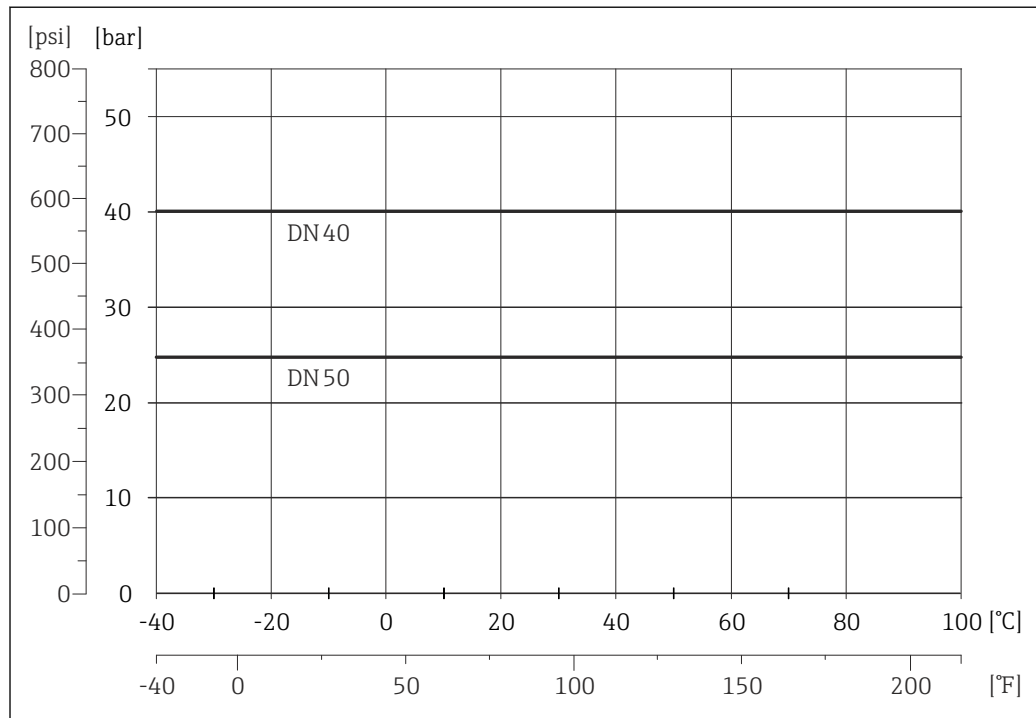

A0022095-EN

13 With stainless steel material, 1.4404 (316L)

Flow limit

See "Measuring range" (→ 5) section

The velocity in the measuring tube should not exceed 5 m/s (16.4 ft/s).

Pressure loss

Negligible.

System pressure

NOTICE

Depending on version:

Observe information on nameplate.

- ▶ Max. 40 bar g (580 psi g)

WARNING

If the coupling is opened incorrectly under full process pressure, the sensor will shoot out. Therefore it must be ensured that the sensor does not accelerate to a dangerous exit velocity.

- ▶ Use a safety chain for pressures > 4.5 bar (65.27 psi) in combination with PEEK clamping ferrules (→ 43).

WARNING

The sensor is exposed to high temperatures.

Risk of burns from hot surfaces or leaking medium!

- ▶ Before commencing work: allow the system and measuring device to cool to a safe temperature.

Thermal insulation

The maximum possible thickness of the thermal insulation layer is:

Order code for "Insertion Length", option L5 "110mm 4": 100 mm (3.94 in)

The following is recommended for thicker insulation layers:

Order code for "Insertion Length", option L6 "330mm 13": 320 mm (12.6 in)

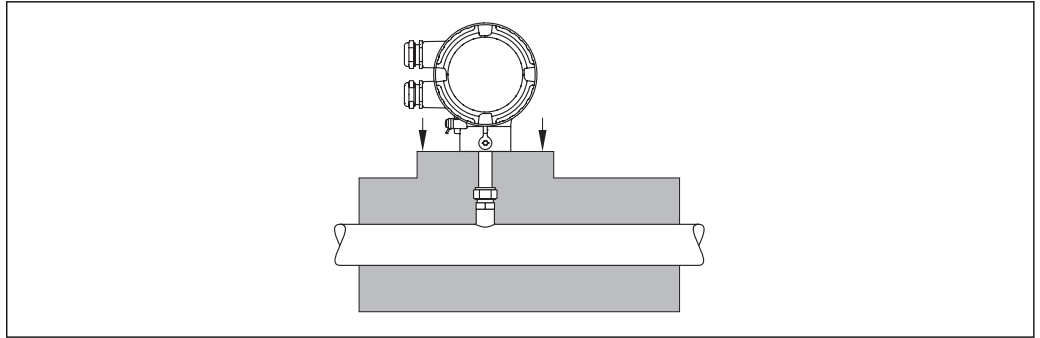

A0015763

Mechanical construction

Design, dimensions

Standard version

Compact version

Order code for "Housing", option A "Compact, alu coated"

Order code for "Insertion Length", option L5 "110mm 4"

Order code for "Insertion Length", option L6 "330mm 13"

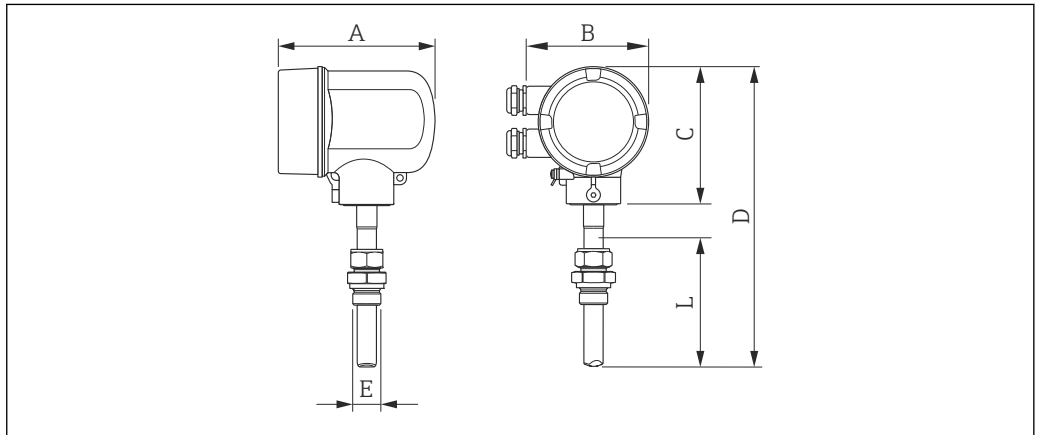

A0021998

Dimensions in SI units

Order code for "Insertion Length"	L [mm]	A ¹⁾ [mm]	B [mm]	C [mm]	D [mm]	E [mm]
L5	110	146	115	129	280	²⁾
L6	330	146	115	129	500	²⁾

1) For version without local display: values - 7 mm

2) dependent on respective process connection

Dimensions in US units



Order code for "Insertion Length"	L [in]	A ¹⁾ [in]	B [in]	C [in]	D [in]	E [in]
L5	4	5.75	4.53	5.08	11.02	²⁾
L6	13	5.75	4.53	5.08	19.69	²⁾

1) For version without local display: values - 0.28 in

2) dependent on respective process connection

Process connections in SI units

Compression fitting G $\frac{3}{4}$

Order code for "Process Connection" ^{1) 2)}	E
Option GA1 "G3/4", compr. fitting, HNBR, PEEK ferrule, ISO 228/1" Option HA1 "G3/4", compr. fitting, EPDM, PEEK ferrule, ISO 228/1" Option GS1 "G3/4", compr. fitting, HNBR, metallic ferrule, ISO 228/1" Option HS1 "G3/4", compr. fitting, EPDM, metallic ferrule, ISO 228/1"	G $\frac{3}{4}$
 Order code for "Process Connection", option GS1 can only be used in conjunction with: Order code for "Insertion Length", option L5 "110mm 4"	
 Order code for "Process Connection", option HS1 can only be used in conjunction with: Order code for "Insertion Length", option L5 "110mm 4"	

- 1) Total length of process coupling: 49 mm
- 2) Total length of process coupling in screwed-in position: 38 mm

Compression fitting $\frac{3}{4}$ NPT

Order code for "Process Connection" ^{1) 2)}	E
Option NA1 "3/4" NPT, compr. fitting, PEEK ferrule" Option NS1 "3/4" NPT, compr. fitting, metallic ferrule"	$\frac{3}{4}$ NPT
 Order code for "Process Connection", option NS1 can only be used in conjunction with: Order code for "Insertion Length", option L5 "110mm 4"	

- 1) Total length of process coupling: 49 mm
- 2) Total length of process coupling in screwed-in position: 38 mm



Union nut and threadolet

Order code for "Process Connection" ¹⁾	E [mm]
Option TP1 "Union nut+threadolet, PEEK ferrule" Option TS1 "Union nut+threadolet, metallic ferrule"	27.6
 Order code for "Process Connection", option TP1 and TS1 can only be used in conjunction with: Order code for "Insertion Length", option L5 "110mm 4"	

- 1) Total Insertion Length of union nut and threadolet: 49 mm

Process connections in US units

Compression fitting G $\frac{3}{4}$

Order code for "Process Connection" ^{1) 2)}	E
Option GA1 "G3/4", compr. fitting, HNBR, PEEK ferrule, ISO 228/1" Option HA1 "G3/4", compr. fitting, EPDM, PEEK ferrule, ISO 228/1" Option GS1 "G3/4", compr. fitting, HNBR, metallic ferrule, ISO 228/1" Option HS1 "G3/4", compr. fitting, EPDM, metallic ferrule, ISO 228/1"	G $\frac{3}{4}$
 Order code for "Process Connection", option GS1 can only be used in conjunction with: Order code for "Insertion Length", option L5 "110mm 4"	
 Order code for "Process Connection", option HS1 can only be used in conjunction with: Order code for "Insertion Length", option L5 "110mm 4"	

- 1) Total length of process coupling: 1.93 in
- 2) Total length of process coupling in screwed-in position: 1.5 in

Compression fitting 3/4NPT

Order code for "Process Connection" ^{1) 2)}	E
Option NA1 "3/4" NPT, compr. fitting, PEEK ferrule" Option NS1 "3/4" NPT, compr. fitting, metallic ferrule"	3/4NPT
i Order code for "Process Connection", option NS1 can only be used in conjunction with: Order code for "Insertion Length", option L5 "110mm 4"	

- 1) Total length of process coupling: 1.93 in
- 2) Total length of process coupling in screwed-in position: 1.5 in

Union nut and threadolet

Order code for "Process Connection" ¹⁾	E [in]
Option TP1 "Union nut+threadolet, PEEK ferrule" Option TS1 "Union nut+threadolet, metallic ferrule"	1.09
i Order code for "Process Connection", option TP1 and TS1 can only be used in conjunction with: Order code for "Insertion Length", option L5 "110mm 4"	

- 1) Total length of union nut and threadolet: 1.93 in

Hygienic version

Compact version

Order code for "Housing", option A "Compact, alu coated"

Order code for "Insertion Length", option LH "Hygienic version"

Process connections in SI units

- i** All hygienic process connections available for order with:
 - Order code for "Additional approval", option LP "3A"
 - Order code for "Additional approval", option LP "EHEDG"
 - Order code for "Insertion Tube Material; Sensor:":
 - Option BB "Stainl. steel, factory length, 0.8 µm, mechanically polished"
 - Option BC "Stainl. steel, factory length, 0.4 µm, mechanically polished"
 - Option CB "..... mm customized length, 0.8 µm, mechanically polished"
 - Option CC "..... mm customized length, 0.4 µm, mechanically polished"

Tri-Clamp

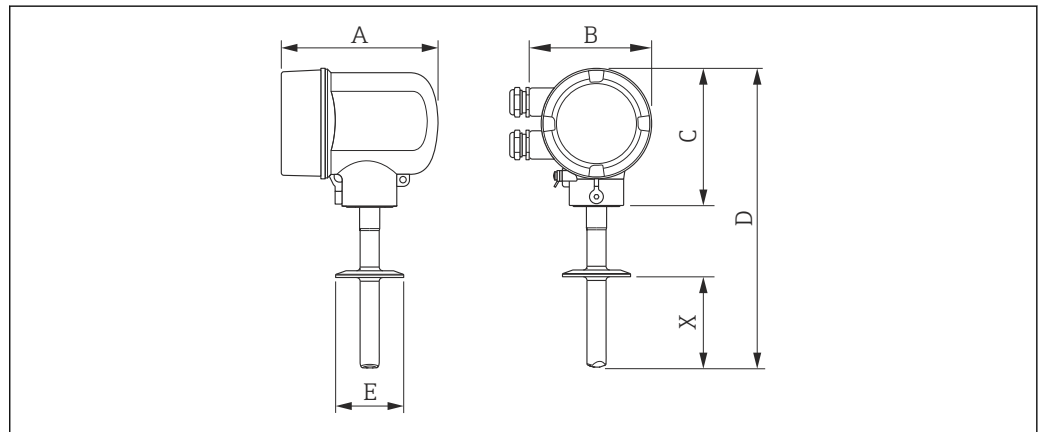

A0021999

1-½"-Tri-Clamp ISO 2852/DIN 32676: order code for "Process Connection", option FAW						
Order code for "Insertion Tube Material; Sensor"	X [mm]	A ¹⁾ [mm]	B [mm]	C [mm]	D [mm]	E [mm]
BB BC	40	146	115	129	280	50.5
CB CC	30 to 85 ²⁾ (→ ☰ 18)	146	115	129	280	50.5

- 1) For version without local display: values - 7 mm
- 2) Prerequisite: customized length is determined

2"-Tri-Clamp ISO 2852/DIN 32676: order code for "Process Connection", option FBW						
Order code for "Insertion Tube Material; Sensor"	X [mm]	A ¹⁾ [mm]	B [mm]	C [mm]	D [mm]	E [mm]
BB BC	40	146	115	129	280	64.0
CB CC	30 to 85 ²⁾ (→ ☰ 18)	146	115	129	280	64.0

- 1) For version without local display: values - 7 mm
- 2) Prerequisite: customized length is determined

DIN 11851 conical coupling (sanitary connection)

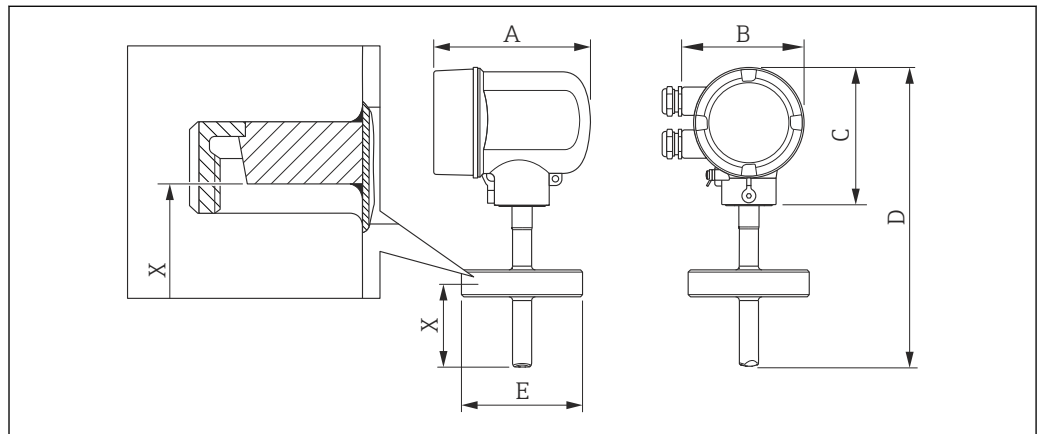

DN 40 conical coupling with union nut (sanitary connection) DIN 11851: order code for "Process Connection", option KAW						
Order code for "Insertion Tube Material; Sensor"	X [mm]	A ¹⁾ [mm]	B [mm]	C [mm]	D [mm]	E [mm]
BB BC	40	146	115	129	280	56.0
CB CC	30 to 85 ²⁾ (→ ☰ 18)	146	115	129	280	56.0

- 1) For version without local display: values - 7 mm
- 2) Prerequisite: customized length is determined

DN 50 conical coupling with union nut (sanitary connection) DIN 11851: order code for "Process Connection", option KBW						
Order code for "Insertion Tube Material; Sensor"	X [mm]	A ¹⁾ [mm]	B [mm]	C [mm]	D [mm]	E [mm]
BB BC	40	146	133	129	280	68.5
CB CC	30 to 85 ²⁾ (→ 18)	146	133	129	280	68.5

- 1) For version without local display: values - 7 mm
- 2) Prerequisite: customized length is determined

DIN 11864-1 Form A aseptic liner

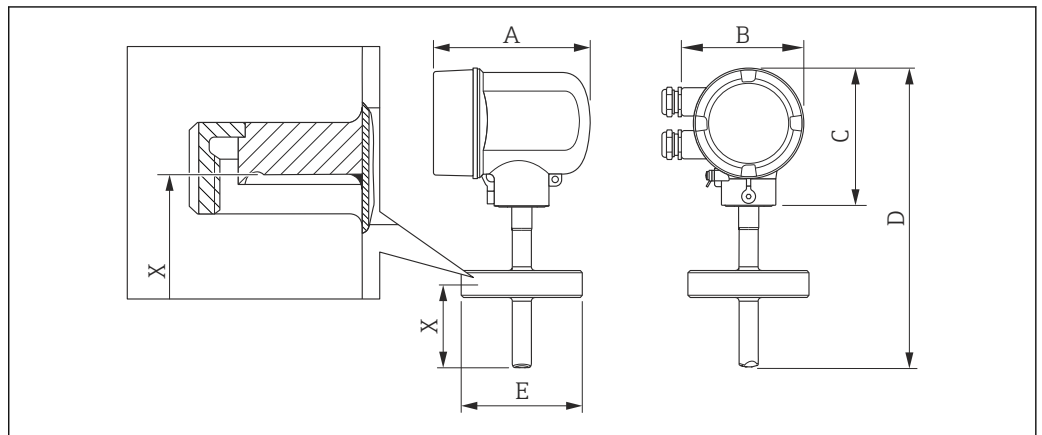

A0022000

DN 40 aseptic liner with union nut DIN 11864-1 Form A: order code for "Process Connection", option KCW						
Order code for "Insertion Tube Material; Sensor"	X [mm]	A ¹⁾ [mm]	B [mm]	C [mm]	D [mm]	E [mm]
BB BC	40	146	115	129	280	54.9
CB CC	30 to 85 ²⁾ (→ 18)	146	115	129	280	54.9

- 1) For version without local display: values - 7 mm
- 2) Prerequisite: customized length is determined

DN 50 aseptic liner with union nut DIN 11864-1 Form A: order code for "Process Connection", option KDW						
Order code for "Insertion Tube Material; Sensor"	X [mm]	A ¹⁾ [mm]	B [mm]	C [mm]	D [mm]	E [mm]
BB BC	40	146	115	129	280	66.9
CB CC	30 to 85 ²⁾ (→ 18)	146	115	129	280	66.9

- 1) For version without local display: values - 7 mm
- 2) Prerequisite: customized length is determined

Process connections in US units



All hygienic process connections available for order with:

- Order code for "Additional approval", option LP "3A"
- Order code for "Additional approval", option LP "EHEDG"
- Order code for "Material of insertion pipe; sensor":
 - Option BB "Stainl. steel, factory length, 0.8 μm , mechanically polished"
 - Option BC "Stainl. steel, factory length, 0.4 μm , mechanically polished"
 - Option CD "..... inch customized length, 0.8 μm , mechanically polished"
 - Option CE "..... inch customized length, 0.4 μm , mechanically polished"

Tri-Clamp

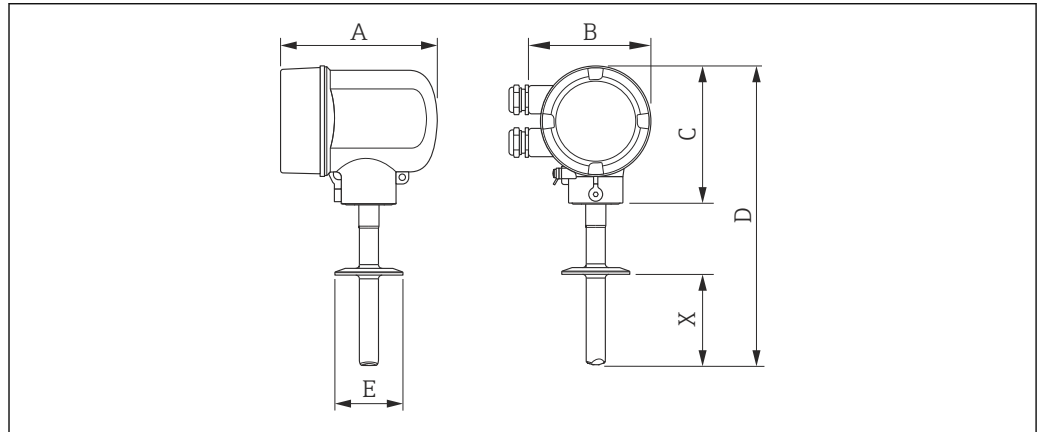

A0021999

1-½"-Tri-Clamp ISO 2852/DIN 32676: order code for "Process Connection", option FAW						
Order code for "Material of insertion pipe; sensor"	X [in]	A ¹⁾ [in]	B [in]	C [in]	D [in]	E [in]
BB BC	1½	5.75	4.53	5.08	11.02	2.0
CD CE	1.2 to 3.3 ²⁾ (→ ☰ 18)	5.75	4.53	5.08	11.02	2.0

- 1) For version without local display: values - 0.28 in
- 2) Prerequisite: customized length is determined

2"-Tri-Clamp ISO 2852/DIN 32676: order code for "Process Connection", option FBW						
Order code for "Insertion Tube Material; Sensor"	X [in]	A ¹⁾ [in]	B [in]	C [in]	D [in]	E [in]
BB BC	1½	5.75	4.53	5.08	11.02	2.52
CD CE	1.2 to 3.3 ²⁾ (→ ☰ 18)	5.75	4.53	5.08	11.02	2.52

- 1) For version without local display: values - 0.28 in
- 2) Prerequisite: customized length is determined

DIN 11851 conical coupling (sanitary connection)

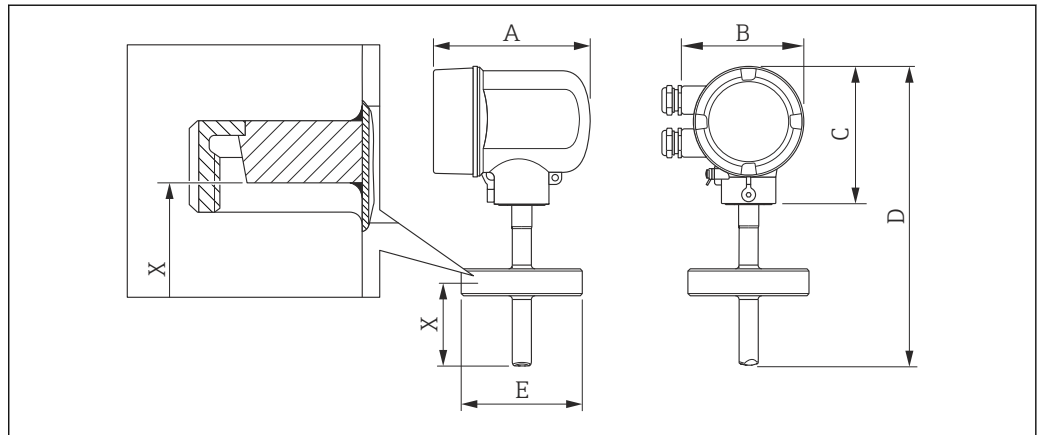

A0022001

DIN 40 conical coupling (sanitary connection) DIN 11851: order code for "Process Connection", option KAW						
Order code for "Insertion Tube Material; Sensor"	X [in]	A ¹⁾ [in]	B [in]	C [in]	D [in]	E [in]
BB BC	1½	5.75	4.53	5.08	11.02	2.2
CD CE	1.2 to 3.3 ²⁾ (→ 18)	5.75	4.53	5.08	11.02	2.2

- 1) For version without local display: values - 0.28 in
- 2) Prerequisite: customized length is determined

DIN 50 conical coupling (sanitary connection) DIN 11851: order code for "Process Connection", option KBW						
Order code for "Insertion Tube Material; Sensor"	X [in]	A ¹⁾ [in]	B [in]	C [in]	D [in]	E [in]
BB BC	1½	5.75	4.53	5.08	11.02	2.7
CD CE	1.2 to 3.3 ²⁾ (→ 18)	5.75	4.53	5.08	11.02	2.7

- 1) For version without local display: values - 0.28 in
- 2) Prerequisite: customized length is determined

DIN 11864-1 Form A (aseptic liner)

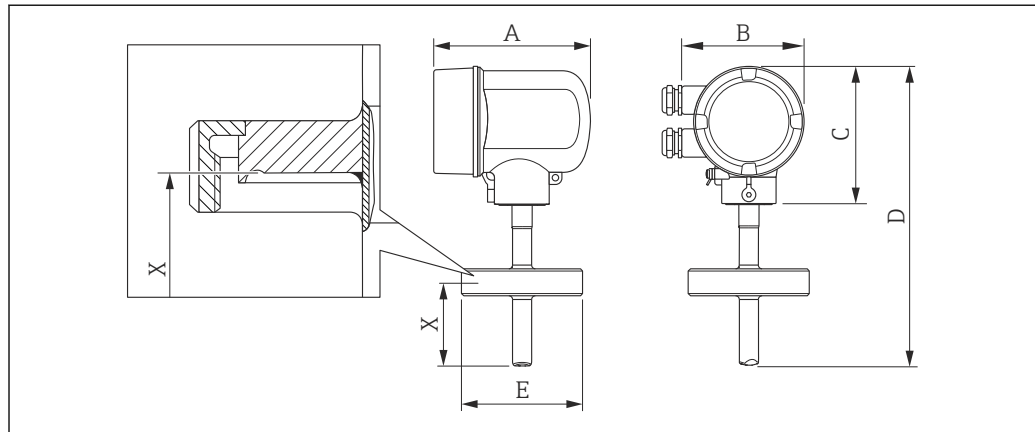

A0022000

DIN 40 aseptic liner DIN 11864-1 Form A: order code for "Process Connection", option KCW						
Order code for "Insertion Tube Material; Sensor"	DN [in]	A ¹⁾ [in]	B [in]	C [in]	D [in]	E [in]
BB BC	1½	5.75	4.53	5.08	11.02	2.16
CD CE	1.2 to 3.3 ²⁾ (→ ☰ 18)	5.75	4.53	5.08	11.02	2.16

- 1) For version without local display: values - 0.28 in
- 2) Prerequisite: customized length is determined

DIN 40 aseptic liner DIN 11864-1 Form A: order code for "Process Connection", option KDW						
Order code for "Insertion Tube Material; Sensor"	X [in]	A ¹⁾ [in]	B [in]	C [in]	D [in]	E [in]
BB BC	1½	5.75	4.53	5.08	11.02	2.63
CD CE	1.2 to 3.3 ²⁾ (→ ☰ 18)	5.75	4.53	5.08	11.02	2.63

- 1) For version without local display: values - 0.28 in
- 2) Prerequisite: customized length is determined

Accessories*Mounting boss*

Order code for "Accessories enclosed", option PE "Mounting boss, G 3/4"

Order code for "Accessories enclosed", option PF "Mounting boss, 3/4" NPT"

i Order code for "Process Connection", options GA1, HA1, NA1, GS1, HS1 and NS1 can only be used in conjunction with:
Order code for "Insertion Length", option L5 "110mm 4"

Hot tap

Low-pressure version and medium-pressure version

- i** Available for order as:
 - Order code for "Accessories enclosed", option PK "Hot tap G 3/4", low pressure = 4.5 bar/65 psig"; option PL "Hot tap 3/4" NPT, low pressure = 4.5 bar/65 psig"
 - Order code for "Accessories enclosed", option PM "Hot tap G 3/4", medium pressure = 16 bar/230 psig "; option PN "Hot tap 3/4" NPT, medium pressure = 16 bar/230 psig"
 - Can be ordered separately as an "accessory": DK6HT-* (→ 43)
- i** Can only be used in conjunction with:
 - Standard version (order code for "Insertion Length", option L6 "330mm 13")
 - Process connections with clamping ferrules in PEEK

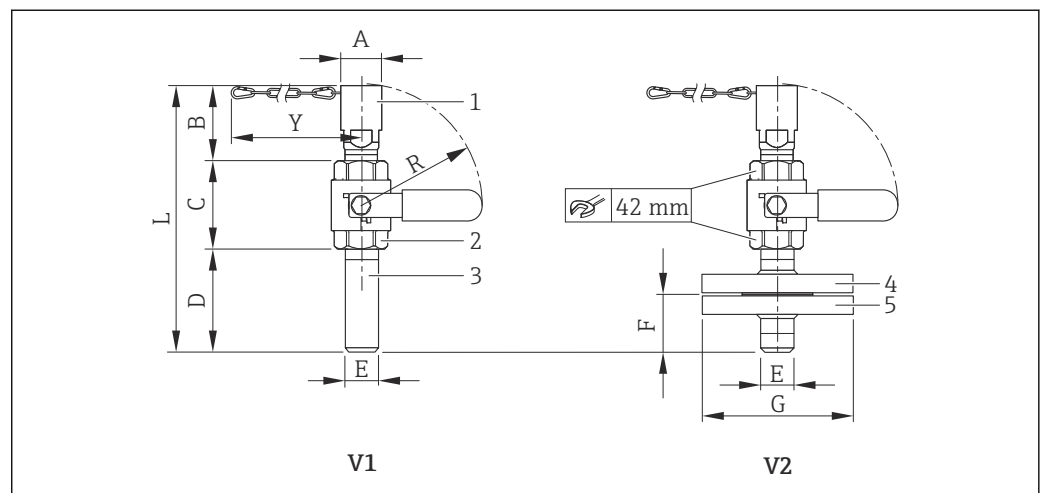

- 1 Sensor connection with safety chain
- 2 Ball valve
- 3 Weld-in nipple process connection
- 4 Flange adapter
- 5 Process connection flange
- V1 Version with weld-in nipple
- V2 Flanged version

SI units

A [mm]	B [mm]	C [mm]	D [mm]	E [mm]	F [mm]	G [mm]	L [mm]	R [mm]	Y ¹⁾ [mm]
42.4	85	88	95	34	54	108 to 125	~268	165	620

1) Safety chain (for p ≥ 4.5 bar) only in conjunction with low-pressure version

US units

A [in]	B [in]	C [in]	D [in]	E [in]	F [in]	G [in]	L [in]	R [in]	Y ¹⁾ [in]
1.67	3.35	3.46	3.74	1.34	2.13	4.25 to 4.92	~10.55	6.5	24.4

1) Safety chain (for p ≥ 65 psi g) only in conjunction with low-pressure version

Extractor assembly

- i** Can only be used in conjunction with:
 - Hot Tap (order code for "Accessories enclosed", option PM "Hot tap G 3/4", medium pressure = 16 bar/230 psig "; option PN "Hot tap 3/4" NPT, medium pressure = 16 bar/230 psig")

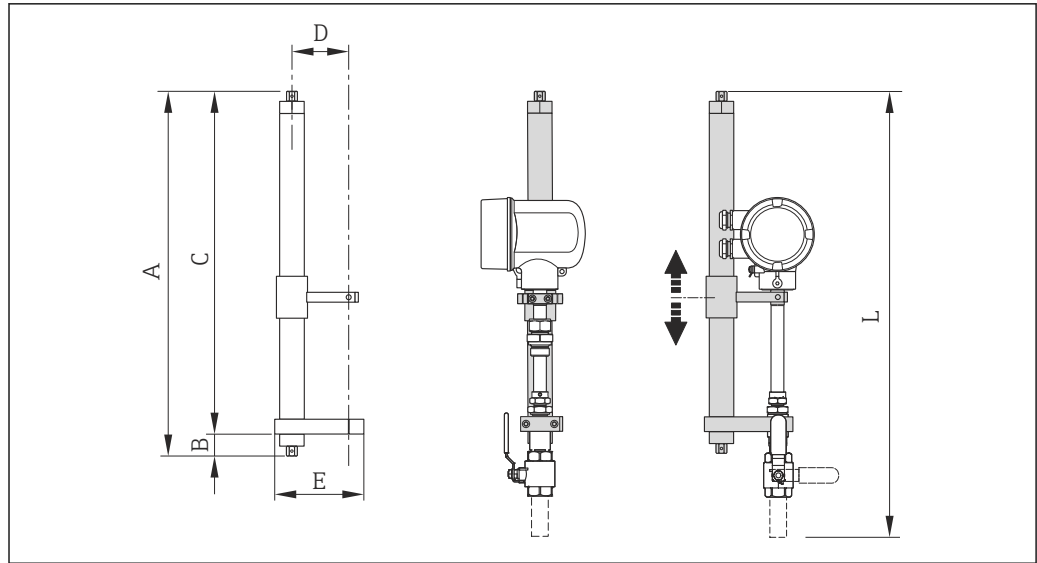

SI units

L [mm]	B [mm]	C [mm]	D [mm]	E [mm]
740	40	700	120	180

US units

L [in]	B [in]	C [in]	D [in]	E [in]
29.13	1.57	27.56	4.72	7.09

Weight

Compact version

- Including the transmitter
- Weight specifications apply to standard pressure ratings and without packaging material.

Standard version

Weight in SI units

Sensor length [mm]	Weight [kg]
Order code for "Insertion Length"	Order code for "Housing", option C "Compact, alu coated"
110	1.8
330	2.0

Weight in US units

Sensor length [in]	Weight [lbs]
Order code for "Insertion Length"	Order code for "Housing", option C "Compact, alu coated"
4	4.0
13	4.4

Hygienic version

Weight in SI units

Sensor length [mm]	Weight [kg]
Order code for "Insertion Length"	Order code for "Housing", option C "Compact, alu coated"
30 to 85	1.8

Weight in US units

Sensor length [in]	Weight [lbs]
Order code for "Insertion Length"	Order code for "Housing", option C "Compact, alu coated"
1 to 3	4.0

Accessories

Hot tap

Weight in SI units

Hot tap Version	Weight [kg]
Version with weld-in nipple (version V1)	2.2
Flanged version (version V2)	4.3
Extractor assembly	7.8

Weight in US units

Hot tap Version	Weight [lbs]
with retrofit adapter (version V1)	4.0
with weld-in nipple (version V2)	4.9
with flange/flange adapter (version V3)	9.5
Extractor assembly	17.5

Materials

Transmitter housing

Compact version

- Order code for "Housing", option A "Compact, alu coated": coated aluminum AlSi10Mg
- Window material: glass

Cable entries/cable glands

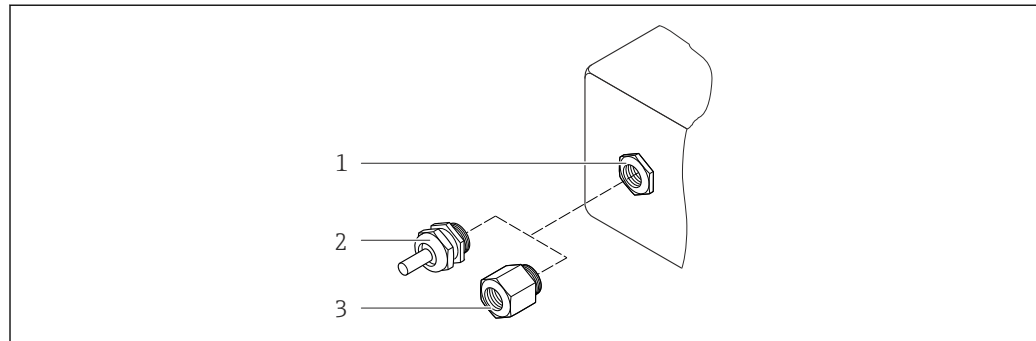

A0020640

14 Possible cable entries/cable glands

- 1 Cable entry in transmitter housing, wall-mount housing or connection housing with internal thread M20 x 1.5
- 2 Cable gland M20 x 1.5
- 3 Adapter for cable entry with internal thread G 1/2" or NPT 1/2"

Order code for "Housing", option A "Compact, alu coated"

Cable entry/cable gland	Type of protection	Material
Cable gland M20 x 1.5	For non-Ex and Ex	Plastic
Adapter for cable entry with internal thread G 1/2"		Nickel-plated brass
Adapter for cable entry with internal thread NPT 1/2"		

Connector

Electrical connection	Material
Connector M12 x 1	<ul style="list-style-type: none"> ▪ Socket: Stainless steel, 1.4404 (316L) ▪ Contact housing: Polyamide ▪ Contacts: Gold-plated brass

Sensor

Transducer

- Standard version
 - Stainless steel, 1.4404 (316/316L)
 - Hastelloy AC22, 2.4602 (N06022)
- Hygienic version:
 - Stainless steel, 1.4404 (316/316L), sensor tip made of Hastelloy AC22, 2.4602 (N06022)

Process connections

Standard version

Compression fitting G 3/4" A, 3/4" NPT:

- Stainless steel, 1.4404 (316L)
- Hastelloy AC22, 2.4602 similar to N06022

Threadolet:

- Stainless steel, 1.4404 (316L)
- Hastelloy AC22, 2.4602 similar to N06022

Union nut for compression fitting and threadolet:

Stainless steel, 1.4571 similar to 316Ti

Clamping ferrules:

- PEEK 450G
- Stainless steel, 1.4404 (316L)
- Hastelloy AC22, 2.4602 (N06022)

Sealing ring EPDM/HNBR for G ¾" A:

Stainless steel, 1.4404 similar to 316L (outer ring)

Hygienic version

- 1-½" Tri-Clamp, 2" Tri-Clamp ISO 2852/DIN 32676:
Stainless steel, 1.4404 (316L)
- Conical coupling, DN40 DIN 11851, DN50 DIN 11851:
Stainless steel, 1.4404 (316L)
- Aseptic liner, DN40 DIN 11864-1A, DN50 DIN 11864-1A:
Stainless steel, 1.4404 (316L)
- Union nut DN40, DN50:
Stainless steel, 1.4301 similar to 304

 List of all available process connections (→  39)

Accessories

Mounting boss

Stainless steel, 1.4404 (316/316L)

Hot tap

- Process connection:
 - Weld-in nipple:
Stainless steel, 1.4404 (316/316L)
 - Flange/flange adapter:
Stainless steel, 1.4404 (316L)
- Sensor connection:
Stainless steel, 1.4404 (316/316L)
- Ball valve:
Stainless steel, CF3M, CF8M
Seal:
PTFE

Weather protection cover

Stainless steel 1.4301

Process connections



Standard version

Compression fitting:

- G ¾ A, ¾" NPT:
ISO 228/1
- Union nut and threadolet

Hygienic version

- Tri-Clamp:
ISO 2852/DIN 32676
- Conical coupling with union nut (sanitary connection):
DIN 11851
- Aseptic liner with union nut:
DIN 11864-1 Form A

 For information on the materials of the process connections (→  37)

Operability

Operating concept

Operator-oriented menu structure for user-specific tasks

- Commissioning
- Operation
- Diagnostics
- Expert level

Quick and safe commissioning

Menu guidance with brief explanations of the individual parameter functions

Reliable operation

- Operation in different languages:
 - Via local display:
 - English, German, French, Spanish, Italian, Dutch, Portuguese, Polish, Russian, Turkish, Chinese, Japanese, Korean, Vietnamese, Czech, Swedish
 - Via "FieldCare" operating tool:
 - English, German, French, Spanish, Italian, Chinese, Japanese
- Uniform operating philosophy applied to device and operating tools

Efficient diagnostics increase measurement availability

- Remedial measures are integrated in plain text
- Diverse simulation options and optional line recorder functions

Local operation

Order code for "Display; Operation", option C "SD02"

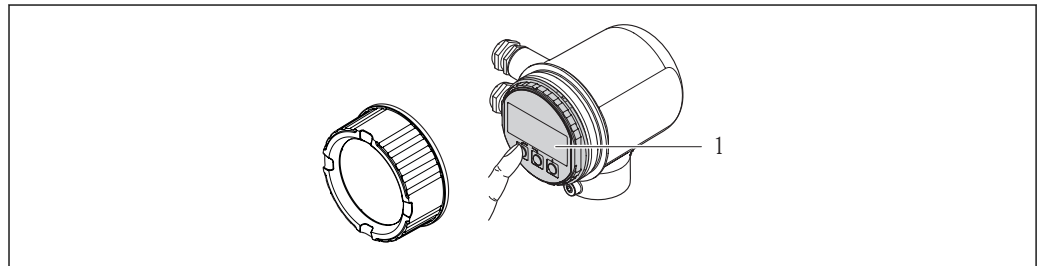



A0017279

1 Operation with pushbuttons

Display elements

- 4-line display
- Format for displaying measured variables and status variables can be individually configured
- Permitted ambient temperature for the display: -20 to $+60$ °C (-4 to $+140$ °F)
The readability of the display may be impaired at temperatures outside the temperature range.

Operating elements

- With order code for "Display; operation", option C:
Local operation with 3 push buttons: , , 
- Operating elements also accessible in various hazardous areas

Additional functionality

- Data backup function
The device configuration can be saved in the display module.
- Data comparison function
The device configuration saved in the display module can be compared to the current device configuration.
- Data transfer function
The transmitter configuration can be transmitted to another device using the display module.

Remote operation

Via HART protocol

This communication interface is present in the following device version:

- Order code for "Output", option A: 4-20 mA HART
- Order code for "Output", option B: 4-20 mA HART, pulse/frequency/switch output
- Order code for "Output", option Q: 4-20 mA HART, pulse/frequency/switch output, status input

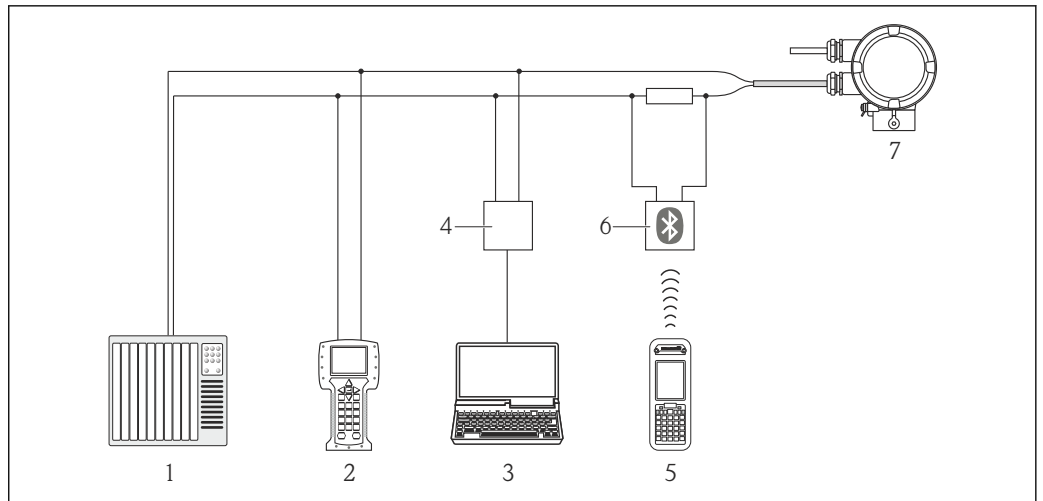

A0017373

15 Options for remote operation via HART protocol

- 1 Control system (e.g. PLC)
- 2 Field Communicator 475
- 3 Computer with operating tool (e.g. FieldCare, AMS Device Manager, SIMATIC PDM)
- 4 Commubox FXA195 (USB)
- 5 Field Xpert SFX350 or SFX370
- 6 VIATOR Bluetooth modem with connecting cable
- 7 Transmitter

Via service interface (CDI)

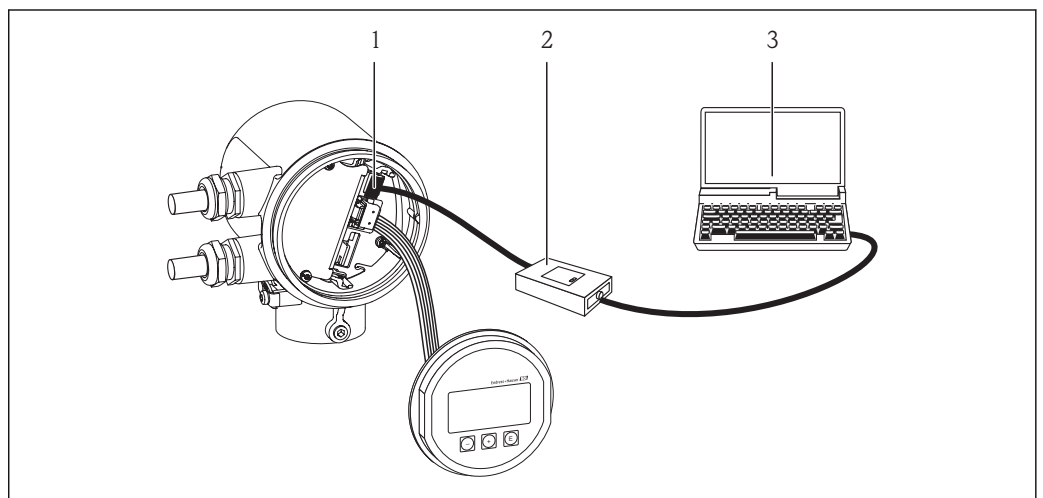

A0017253

- 1 Service interface (CDI) of the measuring device
- 2 Commubox FXA291
- 3 Computer with "FieldCare" operating tool with COM DTM "CDI Communication FXA291"

Certificates and approvals

CE mark

The measuring system is in conformity with the statutory requirements of the applicable EC Directives. These are listed in the corresponding EC Declaration of Conformity along with the standards applied.

Endress+Hauser confirms successful testing of the device by affixing to it the CE mark.

C-Tick symbol

The measuring system meets the EMC requirements of the "Australian Communications and Media Authority (ACMA)".

Ex approval

The measuring device is certified for use in hazardous areas and the relevant safety instructions are provided in the separate "Safety Instructions" (XA) document. Reference is made to this document on the nameplate.



The separate Ex documentation (XA) containing all the relevant explosion protection data is available from your Endress+Hauser sales center.

ATEX, IECEx

Ex nA

Category	Explosion protection
II3G/Zone 2	Ex nA IIC T4-T1

cCSA_{US}

NI

Category	Explosion protection
Class I Division 2 Groups ABCD T4 or Class I	NI (Non-incendive version), NIFW-Parameter*

*= Entity and NIFW parameters according to control drawings

Hygienic compatibility

- 3A approval
- EHEDG-tested



Overview of suitable process connections (→ 39)

Other standards and guidelines

- EN 60529
Degrees of protection provided by enclosures (IP code)
- EN 61010-1
Safety requirements for electrical equipment for measurement, control and laboratory use
- IEC/EN 61326
Emission in accordance with Class A requirements. Electromagnetic compatibility (EMC requirements).
- NAMUR NE 32
Data retention in the event of a power failure in field and control instruments with microprocessors
- NAMUR NE 43
Standardization of the signal level for the breakdown information of digital transmitters with analog output signal.
- NAMUR NE 53
Software of field devices and signal-processing devices with digital electronics
- NAMUR NE 105
Specifications for integrating fieldbus devices in engineering tools for field devices
- NAMUR NE 107
Status classification as per NE107

Ordering information

Your Endress+Hauser sales center can provide detailed ordering information and information on the extended order code.

Application packages

Package	Description
HistoROM extended function	<p>Comprises extended functions concerning the event log and the activation of the measured value memory.</p> <p>Event log:</p> <ul style="list-style-type: none"> ▪ Memory volume is extended from 20 message entries (basic version) to up to 100 entries. ▪ Message entries are visualized via the local display or FieldCare. <p>Data logging (line recorder):</p> <ul style="list-style-type: none"> ▪ Memory capacity for up to 1000 measured values is activated. ▪ 250 measured values can be output via each of the 4 memory channels. The recording interval can be defined and configured by the user. ▪ Data logging is visualized via the local display or FieldCare.

Accessories

Various accessories, which can be ordered with the device or subsequently from Endress+Hauser, are available for the device. Detailed information on the order code in question is available from your local Endress+Hauser sales center or on the product page of the Endress+Hauser website: www.endress.com.





Device-specific accessories

For the transmitter









Accessories	Description
Weather protection cover	<p>Is used to protect the measuring device from the effects of the weather: e.g. rainwater, excess heating from direct sunlight or extreme cold in winter.</p> <p> For details, see Special Documentation SD00333F</p>

For the sensor

Accessories	Description
Mounting boss	<p>Mounting boss for t-mass insertion version with G$\frac{3}{4}$" or $\frac{3}{4}$" NPT compression fittings. Order code DK6MB-*</p>
Threadolet	<p>Threadolet for t-mass T 150 with union nut (<i>order code for "Process Connection", option TP1 and TS1</i>). Order code DK6001-*</p>
Dummy plug	<p>Dummy plug for threadolet.</p> <p>For couplings made of:</p> <ul style="list-style-type: none"> ▪ Stainless steel, 1.4404 similar to 316L ▪ Hastelloy AC22, 2.4602 similar to N06022

Safety chain	For couplings in combination with PEEK clamping ferrules and pressures > 4.5 bar (65.27 psi)(→  26)
Hot tap	<p>If the accessory is ordered as an extended option, only one particular set of standard features is available.</p> <p> Can only be used in conjunction with:</p> <ul style="list-style-type: none"> ▪ The standard version (order code for "Insertion Length", option L6 "330mm 13") ▪ Process connections with clamping ferrules in PEEK <p>Low pressure, order code for "Accessories enclosed", options PK, PL</p> <p>Mounting set contains weld-in nipple (process connection), sensor connection with safety chain and ball valve. To insert or remove the sensor at process pressures up to max. 4.5 bar g (65 psi).</p> <p>High pressure, order code for "Accessories enclosed", options PM, PN</p> <p>Mounting set contains weld-in nipple (process connection), sensor connection, ball valve and extractor assembly. To insert or remove the sensor at process pressures up to max. 16 bar g (235 psi).</p> <p> For details, see Installation Instructions EA00109D</p> <p> If the accessory is ordered separately, individual combinations can be selected. Order code DK6HT-*</p>

Communication-specific accessories

Accessories	Description
Commubox FXA195 HART	For intrinsically safe HART communication with FieldCare via the USB interface.  For details, see "Technical Information" TI00404F
Commubox FXA291	Connects Endress+Hauser field devices with a CDI interface (= Endress+Hauser Common Data Interface) and the USB port of a computer or laptop.  For details, see "Technical Information" TI00405C
HART Loop Converter HMX50	Is used to evaluate and convert dynamic HART process variables to analog current signals or limit values.  For details, see "Technical Information" TI00429F and Operating Instructions BA00371F
Wireless HART adapter SWA70	Is used for the wireless connection of field devices. The WirelessHART adapter can be easily integrated into field devices and existing infrastructures, offers data protection and transmission safety and can be operated in parallel with other wireless networks with minimum cabling complexity.  For details, see Operating Instructions BA00061S
Fieldgate FXA320	Gateway for the remote monitoring of connected 4-20 mA measuring devices via a Web browser.  For details, see "Technical Information" TI00025S and Operating Instructions BA00053S
Fieldgate FXA520	Gateway for the remote diagnostics and remote configuration of connected HART measuring devices via a Web browser.  For details, see "Technical Information" TI00025S and Operating Instructions BA00051S
Field Xpert SFX350	Field Xpert SFX350 is a mobile computer for commissioning and maintenance. It enables efficient device configuration and diagnostics for HART and FOUNDATION fieldbus devices in the non-Ex area .  For details, see Operating Instructions BA01202S
Field Xpert SFX370	Field Xpert SFX370 is a mobile computer for commissioning and maintenance. It enables efficient device configuration and diagnostics for HART and FOUNDATION fieldbus devices in the non-Ex area and the Ex area .  For details, see Operating Instructions BA01202S

Service-specific accessories

Accessories	Description
W@M	<p>Life cycle management for your plant</p> <p>W@M supports you with a wide range of software applications over the entire process: from planning and procurement, to the installation, commissioning and operation of the measuring devices. All the relevant device information, such as the device status, spare parts and device-specific documentation, is available for every device over the entire life cycle.</p> <p>The application already contains the data of your Endress+Hauser device. Endress+Hauser also takes care of maintaining and updating the data records.</p> <p>W@M is available:</p> <ul style="list-style-type: none"> ▪ Via the Internet: www.endress.com/lifecyclemanagement ▪ On CD-ROM for local PC installation.
FieldCare	<p>FDT-based plant asset management tool from Endress+Hauser.</p> <p>It can configure all smart field units in your system and helps you manage them. By using the status information, it is also a simple but effective way of checking their status and condition.</p> <p> For details, see Operating Instructions BA00027S and BA00059S</p>

System components

Accessories	Description
Memograph M graphic display recorder	<p>The Memograph M graphic display recorder provides information on all relevant measured variables. Measured values are recorded correctly, limit values are monitored and measuring points analyzed. The data are stored in the 256 MB internal memory and also on a SD card or USB stick.</p> <p> For details, see "Technical Information" TI00133R and Operating Instructions BA00247R</p>

Documentation

-  The following document types are available:
- On the CD-ROM supplied with the device
 - In the Download Area of the Endress+Hauser Internet site: www.endress.com → Download

Standard documentation

Communication	Document type	Documentation code
----	Brief Operating Instructions	KA01155D
HART	Operating Instructions	BA01260D

Supplementary device-dependent documentation

Document type	Contents	Documentation code
Safety Instructions	ATEX/IECEx Ex nA	XA01237D
Installation Instructions		Specified for each individual accessory (→  43)

Registered trademarks

HART®
Registered trademark of the HART Communication Foundation, Austin, USA

Applicator®, FieldCare®, Field Xpert™, HistoROM®
Registered or registration-pending trademarks of the Endress+Hauser Group



www.addresses.endress.com
