



Level



Pressure



Flow



Temperature



Liquid
Analysis



Registration



Systems
Components



Services



Solutions

Technical Information

Smartec S CLD132

Measuring system with inductive sensor for conductivity and concentration measurement in the food industry



Application

- Product monitoring in breweries, dairies and the beverage industry
- CIP system control
- Phase separation of product/water and product/product mixtures in pipe systems
- Alkali and acid concentration control in remaking
- Monitoring and control of bottle cleaning systems

Your benefits

- Transmitter housing made of stainless steel
- Sensor made of highly resistant plastic (PEEK)
- Sterilisable sensor
- High measuring reliability due to extensive self-monitoring functions
- Insensitive to polarisation and soiling
- Versions with ultrafast temperature response ($t_{90} < 5$ s) available
- Sensor versions for all process connections used in hygienic applications
- Various operating possibilities:
 - Keys
 - HART® hand-held terminal
 - PROFIBUS PA/DP
 - PC with Commuwin II software
- Large two-line display allows simultaneous display of measured value and temperature
- Standard version extendable by function extension with remote parameter set switching (measuring range switching)

With
quality certificate

Function and system design

Measuring principle

Inductive conductivity measurement

A generator (1) generates an alternating magnetic field in the primary coil (2) which induces a current in the medium (3). The strength of the induced current depends on the conductivity and thus the ion concentration of the medium. The current flow in the medium generates another magnetic field in the secondary coil (4). The resulting current induced in the coil is measured by the receiver (5) and processed to determine the conductivity.

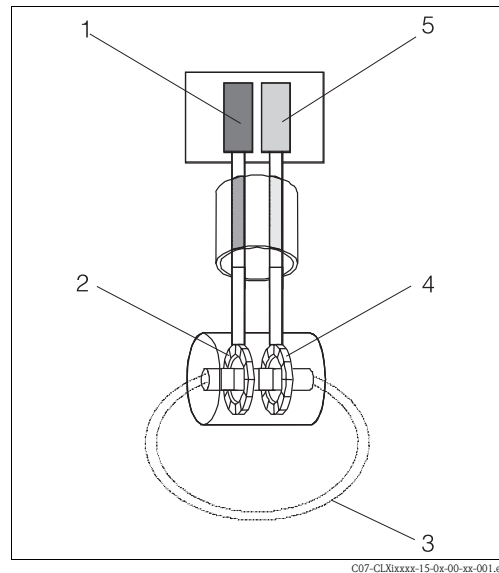

Inductive conductivity measurement

- 1 Generator
- 2 Primary coil
- 3 Current flow in the medium
- 4 Secondary coil
- 5 Receiver

Benefits of inductive conductivity measurement

- No electrodes, therefore no polarisation
- Accurate measurement in media or solutions with a high soiling degree and a tendency to deposition
- Complete galvanic separation of measurement and medium

Important properties of Smartec S CLD132

■ Hygiene

The sensor, injection-moulded from highly chemically, mechanically and thermally resistant PEEK (polyether ether keton), does not have joints or crevices and is therefore hygienically safe.

■ Temperature measurement

- For applications requiring quick temperature measurement (e.g. CIP return, phase separation at various temperatures), the Pt 100 temperature sensor is installed in a stainless-steel thermal conductivity socket that is sealed by a Chemraz O-ring. This ensures extremely fast temperature response times ($t_{90} < 5$ s).
 - For high-load applications, particularly for alternating thermal load due to very frequent sterilisation cycles or temperature shocks, the Pt 100 temperature sensor is embedded in the PEEK sensor body thus eliminating the need for a seal. This ensures a long service life.
- This sensor version can also be applied at underpressure.

■ Temperature compensation

Smartec S CLD132 offers the following types of temperature compensation:

- Linear compensation with freely selectable temperature coefficient α
- Compensation according to IEC 746-3 for NaCl
- Compensation with freely programmable coefficient table with 10 elements maximum

■ Process temperature

The use of special components and materials makes the sensor suitable for continuous exposure to temperatures of +125 °C. Short-time (max. 30 min.), it will work at +140 °C for sterilisation.

■ Concentration measurement

The transmitter can be switched from conductivity operating mode to concentration operating mode. The concentration operating mode provides one freely programmable as well as various predefined concentration curves, especially for common CIP solutions. This enables a direct display of the concentration in %.

■ Remote parameter set switching

Smartec S CLD132 can be ordered with remote parameter set switching (measuring range switching, MRS) enabling you

- to cover a wide measuring range
- to adjust temperature compensation when changing the product
- to switch between concentration curves.

Measuring system

A complete measuring system comprises:

- the Smartec S CLD132 transmitter
- the CLS52 conductivity sensor with integrated temperature sensor and fixed cable
or
- the CLD132 compact version with integrated CLS52 conductivity sensor

Optional for the separate version: CLK5 extension cable, VBM junction box, mounting kit for pipe mounting

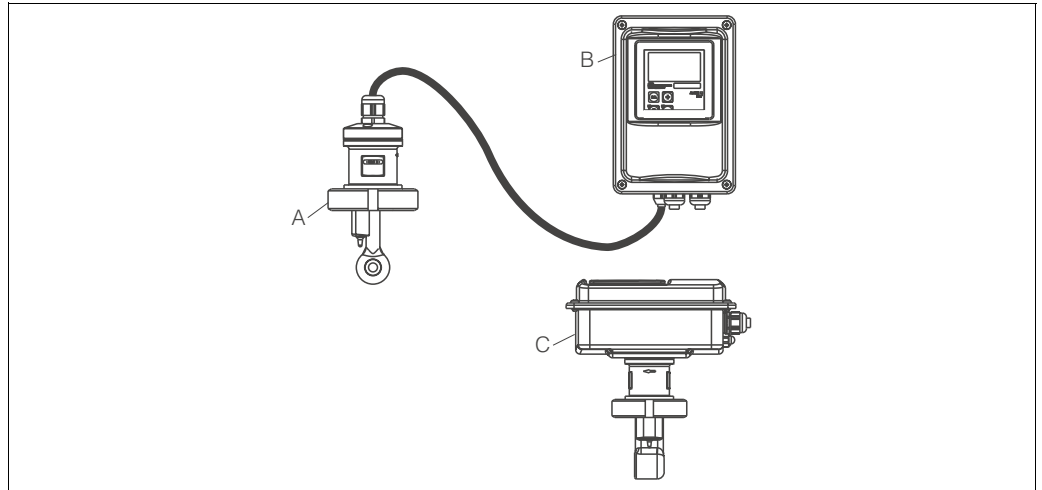

Complete measuring systems Smartec S CLD132 as separate transmitter and compact version

- A CLS52 conductivity sensor
- B Smartec S CLD132 transmitter
- C Smartec S CLD132 compact version with integrated CLS52

Input

Measured variables

Conductivity
Concentration
Temperature

Measuring range

Conductivity: recommended range: 100 µS/cm ... 2000 mS/cm (uncompensated)
 Concentration:
 NaOH: 0 ... 15 %
 HNO₃: 0 ... 25 %
 H₂SO₄: 0 ... 30 %
 H₃PO₄: 0 ... 15 %
 User 1 (... 4): (4 tables available in versions with remote parameter set switching)
 Temperature: -35 ... +250 °C / -31 ... +482 °F

Sensor cable

max. cable length 55 m / 180.46 ft with CLK5 cable (separate version)

Binary inputs 1 and 2

Voltage: 10 ... 50 V DC
 Current consumption: max. 10 mA at 50 V

Output

Output signal	Conductivity: 0 / 4 ... 20 mA, galvanically isolated Temperature (optional second current output)
Signal on alarm	2.4 mA or 22 mA error current
Load	max. 500 Ω
Output range	Conductivity: adjustable Temperature: adjustable
Signal resolution	max. 700 digits/mA
Separation voltage	max. 350 V _{RMS} / 500 V DC
Minimum distance of output signal	Conductivity: Measured value 0 ... 19.99 $\mu\text{S/cm}$: 2 $\mu\text{S/cm}$ Measured value 20 ... 199.9 $\mu\text{S/cm}$: 20 $\mu\text{S/cm}$ Measured value 200 ... 1999 $\mu\text{S/cm}$: 200 $\mu\text{S/cm}$ Measured value 0 ... 19.99 mS/cm: 2 mS/cm Measured value 20 ... 200 mS/cm: 20 mS/cm Measured value 200 ... 2000 mS/cm: 200 mS/cm Concentration: no minimum distance Temperature: 15 °C / 59 °F
Overvoltage protection	acc. to EN 61000-4-5:1995
Auxiliary voltage output	Output voltage: 15 V \pm 0.6 V Output current: max. 10 mA
Contact outputs	Switching current with ohmic load ($\cos \varphi = 1$): max. 2 A Switching current with inductive load ($\cos \varphi = 0.4$): max. 2 A Switching voltage: max. 250 V AC, 30 V DC Switching power with ohmic load ($\cos \varphi = 1$): max. 500 VA AC, 60 W DC Switching power with inductive load ($\cos \varphi = 0.4$): max. 500 VA AC
Limit contactor	Pickup / dropout delay: 0 ... 2000 s (versions with remote parameter set switching only)
Alarm	Function (switchable): steady / fleeting contact Alarm delay: 0 ... 2000 s (min)

Power supply

Electrical connection

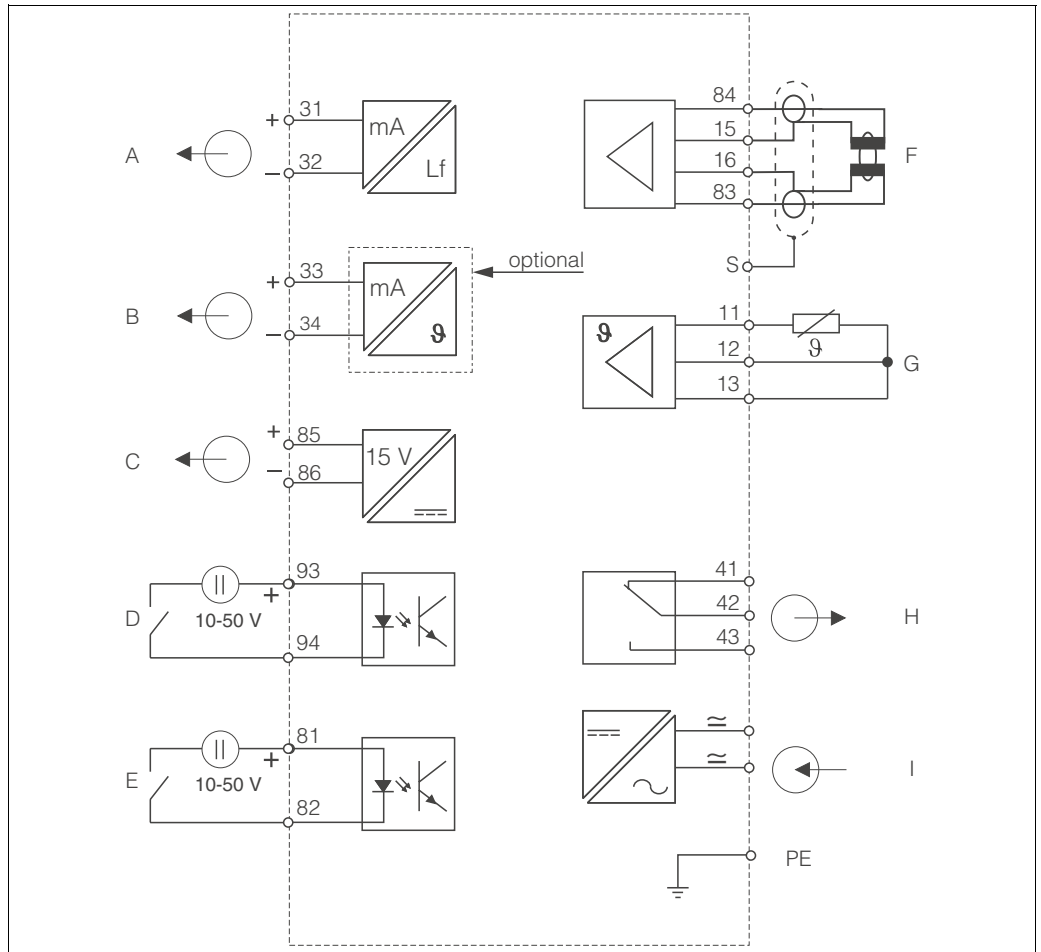

C07-CLD132xx-05-06-00-xx-003.EPS

Electrical connection of CLD132

- A Signal output 1 conductivity
- B Signal output 2 temperature
- C Auxiliary power output
- D Binary input 2 (MRS 1+2)
- E Binary input 1 (hold / MRS 3+4)

- F Conductivity sensor
- G Temperature sensor
- H Alarm (contact position: no current)
- I Power supply

MRS: Remote parameter set switching (measuring range switching)

Sensor connection

The conductivity sensor of the separate version is connected using the shielded multi-core fixed cable. Use the junction box VBM and the CLK5 extension cable (see Accessories) to extend the cable length.

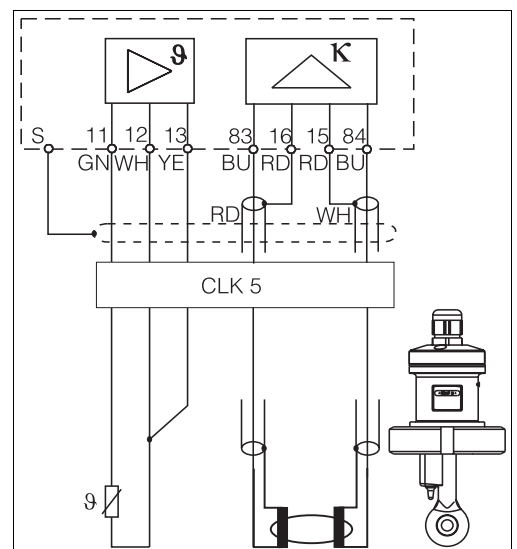

C07-CLD132xx-05-06-00-xx-006.EPS

Electrical connection of CLS52

Supply voltage Depending on ordered version:
 100 / 115 / 230 V AC +10 / -15 %, 48 ... 62 Hz
 24 V AC/DC +20 / -15 %

Cable entries

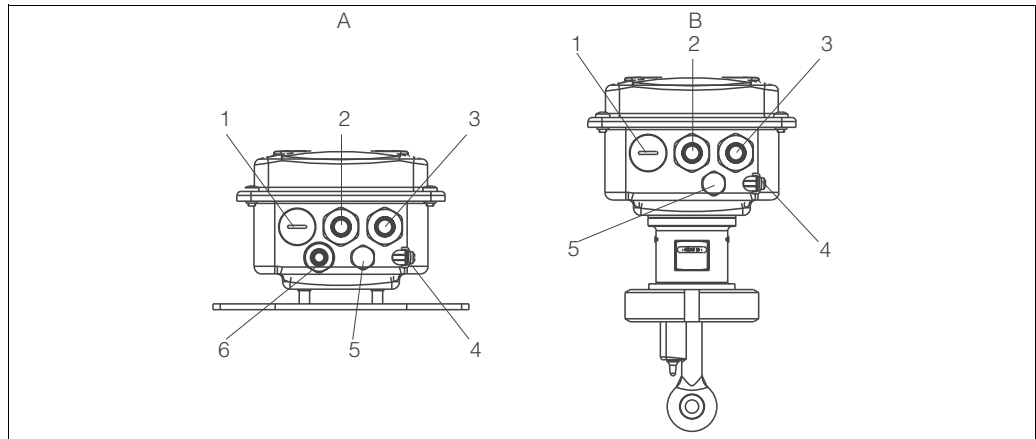

Terminal assignments of cable glands on Smartec S CLD132

- | | | | |
|----------|--|----------|--|
| <i>A</i> | <i>Separate version</i> | <i>B</i> | <i>Compact version</i> |
| 1 | Plug, analog output, binary input | 1 | Plug, analog output, binary input |
| 2 | Cable gland for alarm contact | 2 | Cable gland for alarm contact |
| 3 | Cable gland for power supply | 3 | Cable gland for power supply |
| 4 | Housing ground | 4 | Housing ground |
| 5 | Pressure comp. element PCE (Goretex® filter) | 5 | Pressure comp. element PCE (Goretex® filter) |
| 6 | Cable gland for sensor connection, Pg 9 | | |

C07-CLD132xx-04-06-04-xx-001.eps

Power consumption max. 7.5 VA

Mains fuse Fine-wire fuse, medium time lag, 250 V / 3.15 A

Performance characteristics

Measured value resolution Temperature: 0.1 °C / 0.18 °F

Temperature response time $t_{90} < 5$ s versions with stainless steel socket (CLD132-*****1/2)
 $t_{90} < 3.5$ min versions with encapsulated Pt 100 (CLD132-*****6/7)

Measured error of the sensor^a Conductivity:
 - -5 ... +100 °C / 23 ... 212 °F ± (10 µS/cm + 0.5 % of measured value)
 - > 100 °C / > 212 °F ± (30 µS/cm + 0.5 % of measured value)
 Temperature: Pt 100 class A acc. to IEC 751

Measured error of the transmitter^a Conductivity:
 - Display: max. 0.5 % of measured value ± 4 digits
 - Conductivity signal output: max. 0.75 % of current output range
 Temperature
 - Display: max. 0.6 % of measuring range
 - Temperature signal output: max. 0.75 % of current output range

Repeatability^a Conductivity: max. 0.2% of measured value ± 2 digits

a) acc. to IEC 60746 part 1, at nominal operating conditions

Cell constant	5.9 cm ⁻¹	
Measuring frequency (oscillator)	2 kHz	
Temperature compensation	Range:	-10 ... +150 °C / 14 ... 302 °F
	Compensation types:	<ul style="list-style-type: none"> - none - linear with freely selectable temperature coefficient α - one freely programmable coefficient table (four tables available in versions with remote parameter set switching) - NaCl acc. to IEC 746-3
	Minimum distance for table:	1 K
Reference temperature	25 °C / 77 °F	
Temperature offset	adjustable, ± 5 °C / 9 °F, for temperature display adjustment	

Installation

Installation instructions

In narrow installation conditions, the ion flow in the medium is affected by the pipe walls. This effect is compensated by the so-called installation factor. The installation factor can be entered in the transmitter or the cell constant can be corrected by multiplication with the installation factor to ensure correct measurement.

The value of the installation factor depends on the diameter and the conductivity of the pipe as well as the sensor's distance from the wall.

If the distance from the wall is sufficient ($a > 15$ mm, from DN 65), it is not necessary to consider the installation factor ($f = 1.00$).

If the distance from the wall is smaller, the installation factor increases in case of electrically insulating pipes ($f > 1$) and decreases in case of electrically conductive pipes ($f < 1$).

The installation factor can be measured using calibration solutions or it can be approximately determined from the diagram below.

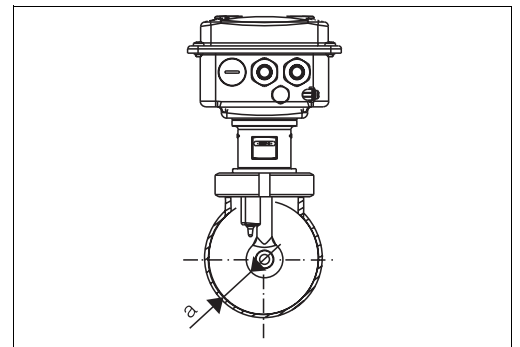

CLD132 installation

a Wall distance

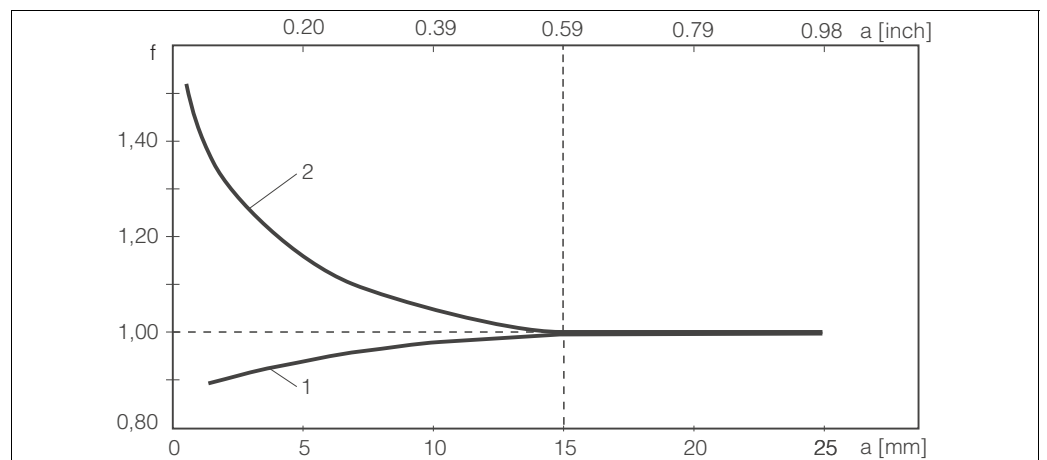

Relationship between installation factor f and distance from wall a

- 1 Electrically conductive pipe wall
- 2 Insulating pipe wall

Air set To compensate residual coupling in the cable and between the two sensor coils, you must perform a zero calibration in air ("air set") before installing the sensor.

Mounting CLD132 separate version

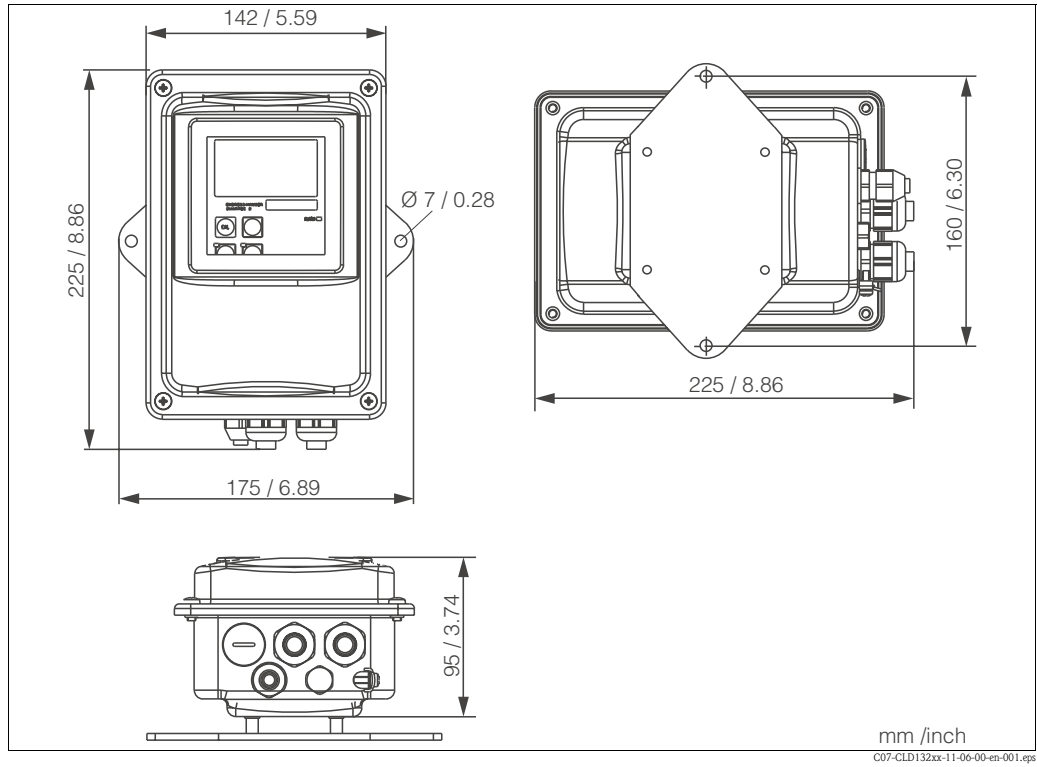

CLD132 wall mounting

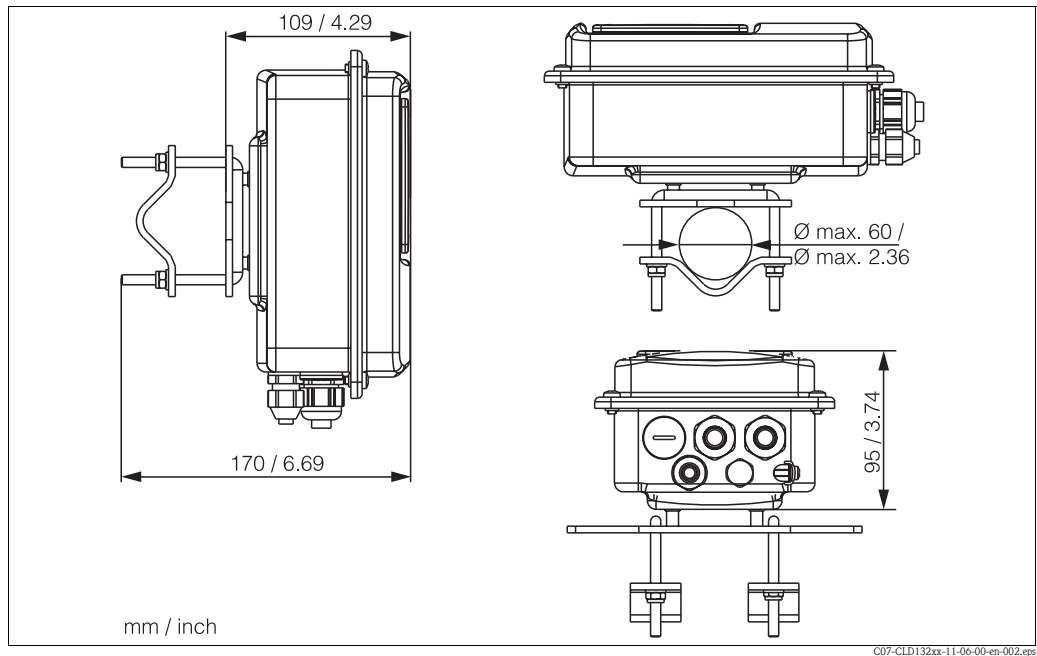

CLD132 mounting on pipes ($\varnothing 60 \text{ mm} / 2.36''$) using the pipe mounting kit (see Accessories)

Mounting CLD132 compact version

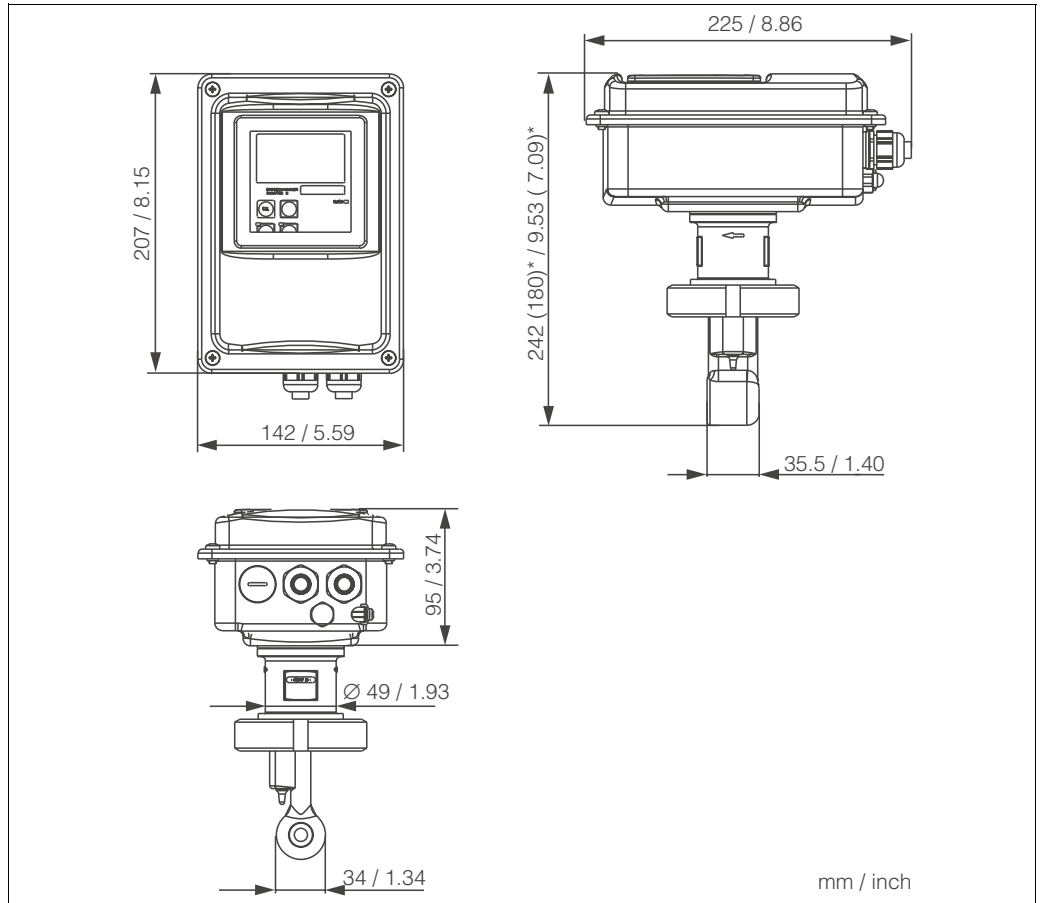

Dimensions of CLD132 compact version

* depending on ordered process connection

C07-CLD132xx-11-06-00-xx-004.eps

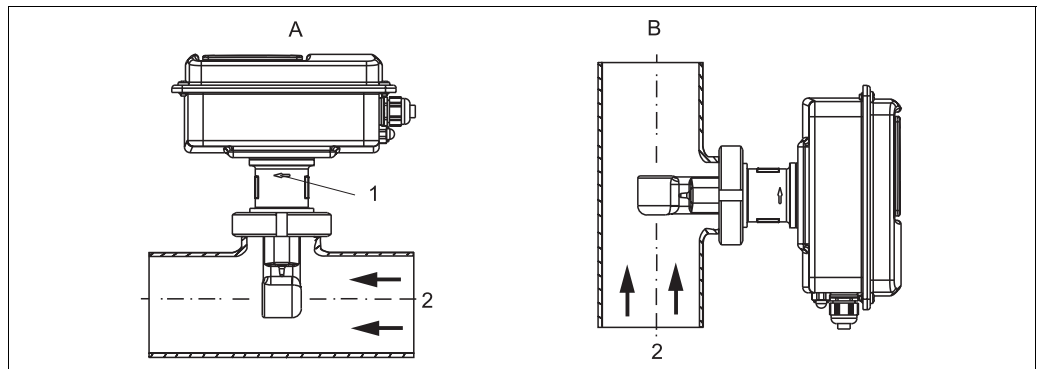

Orientation of CLD132 compact version

- A Horizontal flow
- B Vertical flow
- 1 Orientation arrow
- 2 Flow direction

C07-CLD132xx-11-06-00-xx-006.eps



Note!

The housing can be rotated against the sensor to allow comfortable viewing of the display in any mounting position.

Environment

Ambient temperature	0 ... +55 °C / 32 ... 131 °F	
Ambient temperature limits	-10 ... +70 °C / 14 ... 158 °F (separate version) -10 ... +55 °C / 14 ... 131 °F (compact version) See figure "Permissible temperature ranges of Smartec S CLD132" on page 11.	
Storage temperature	-25 ... +70 °C / -13 ... 158 °F	
Electromagnetic compatibility	Interference emission and interference resistance acc. to EN 61326: 1997 / A1: 1998	
Ingress protection	IP 67	
Relative humidity	10 ... 95%, non-condensing	
Vibration resistance acc. to IEC 60770-1 and IEC 61298-3	Oscillation frequency:	10 ... 500 Hz
	Deflection (peak value):	0.15 mm / 0.01"
	Acceleration (peak value):	19.6 m/s ²
Impact resistance	Display window:	9 J

Process

Process temperature	CLS52 sensor with separate version:	max. 125 °C / 257 °F at 70 °C / 158 °F ambient temperature
	Compact version:	max. 125 °C / 257 °F at 35 °C / 95 °F ambient temperature max. 55 °C / 131 °F at 55 °C / 131 °F ambient temperature
Sterilisation	CLS52 sensor with separate version:	140 °C / 284 °F at 70 °C / 158 °F ambient temperature, 4 bar / 58 psi, max. 30 min
	Compact version:	140 °C / 284 °F at 35 °C / 95 °F ambient temperature, 4 bar / 58 psi, max. 30 min
Process pressure	max. 16 bar (90 °C) / 232 psi (194 °F) no underpressure allowed with versions with stainless steel socket (CLD132*****1, CLD132*****2)	

Permissible temperature ranges of Smartec S CLD132

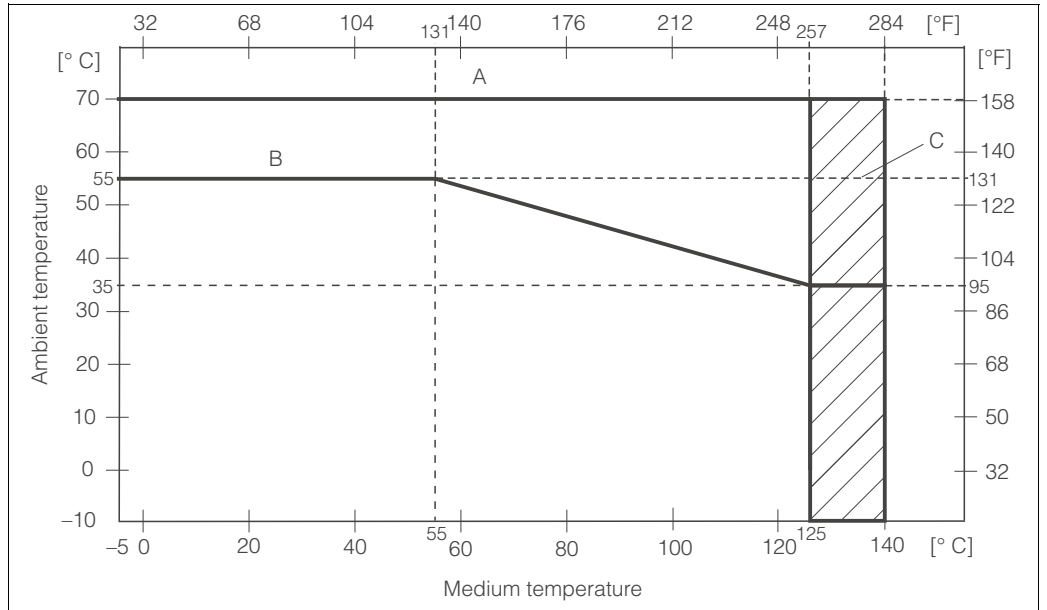

Permissible temperature ranges of Smartec S CLD132

- A CLS52 sensor with separate version
- B Compact version
- C Short-term for sterilisation (< 30 min)

Pressure-temperature load curve of CLS52 sensor

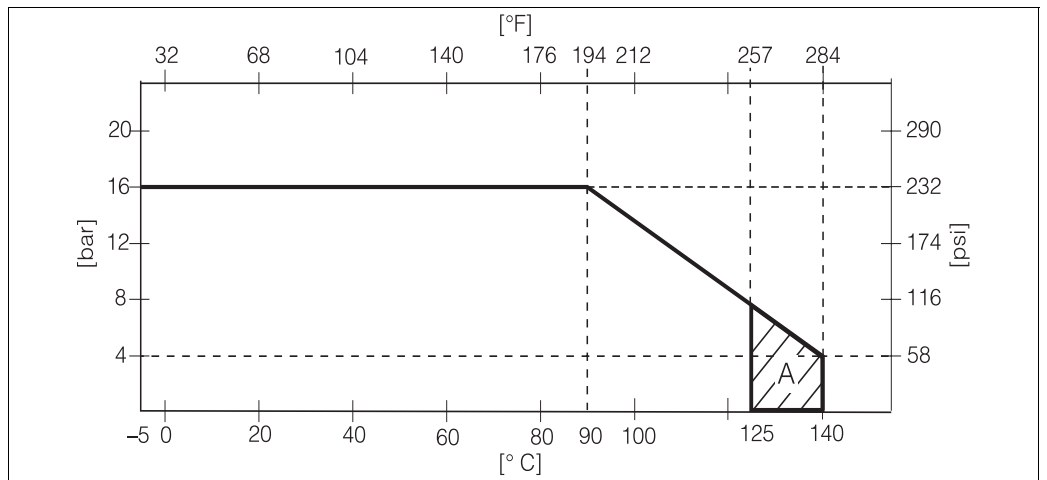

Permissible pressure and temperature ranges of CLS52 sensor

- A short-term for sterilisation (< 30 min)

Mechanical construction

Dimensions	Separate transmitter with mounting plate:	L x W x D: 225 x 142 x 109 mm / 8.86 x 5.59 x 4.29"
	Compact transmitter	
	MV1, CS1, GE1, SMS versions:	L x W x D: 225 x 142 x 242 mm / 8.86 x 5.59 x 9.53"
	VA1, AP1 versions:	L x W x D: 225 x 142 x 180 mm / 8.86 x 5.59 x 7.09"

Weight	Separate version:	
	Transmitter:	approx. 2.5 kg / 5.5 lb.
	CLS52 sensor	depending on version , approx. 400 ... 800 g / 0.9 ... 1.8 lb.
	Compact version with CLS52 sensor:	approx. 3 kg / 6.6 lb.

Materials of the sensor (in contact with medium)	Sensor	PEEK-GF20
	Varivent flange, APF flange:	
	Flange:	stainless steel 1.4435 (AISI 316L)
	Seal:	EPDM
	Metall temperature sensor socket:	
	Socket:	stainless steel 1.4435 (AISI 316L)
	Seal:	Chemraz®

Materials of the transmitter	Housing:	stainless steel 1.4301
	Front window:	polycarbonate

Chemical durability of the sensor

Medium	Concentration	PEEK	1.4435 (AISI 316L)	Chemraz	EPDM
Caustic soda NaOH	0 ... 10 %	20 ... 100 °C / 68 ... 212 °F	20 ... 90 °C / 68 ... 194 °F	20 ... 100 °C / 68 ... 212 °F	20 ... 100 °C / 68 ... 212 °F
	0 ... 50 %	20 ... 100 °C / 68 ... 212 °F	20 ... 90 °C / 68 ... 194 °F	20 ... 100 °C / 68 ... 212 °F	20 ... 60 °C / 68 ... 140 °F
Nitric acid HNO ₃	0 ... 10 %	20 ... 100 °C / 68 ... 212 °F	20 ... 100 °C / 68 ... 212 °F	20 ... 100 °C / 68 ... 212 °F ¹	20 °C / 68 °F
	0 ... 25 %	20 ... 40 °C / 68 ... 104 °F	20 ... 100 °C / 68 ... 212 °F	20 ... 100 °C / 68 ... 212 °F ¹	not suitable
Phosphoric acid H ₃ PO ₄	0 ... 10 %	20 ... 100 °C / 68 ... 212 °F	20 ... 100 °C / 68 ... 212 °F	20 ... 100 °C / 68 ... 212 °F	20 ... 80 °C / 68 ... 176 °F
	0 ... 30 %	20 ... 100 °C / 68 ... 212 °F	20 ... 85 °C / 68 ... 185 °F	20 ... 100 °C / 68 ... 212 °F	20 ... 80 °C / 68 ... 176 °F
Sulphuric acid H ₂ SO ₄	0 ... 2.5 %	20 ... 100 °C / 68 ... 212 °F ¹	20 ... 70 °C / 68 ... 158 °F	20 ... 100 °C / 68 ... 212 °F	20 ... 30 °C / 68 ... 86 °F
	0 ... 30 %	20 ... 100 °C / 68 ... 212 °F ¹	not suitable	20 ... 100 °C / 68 ... 212 °F	20 ... 30 °C / 68 ... 86 °F

1) slight affect possible

No responsibility is taken for the correctness of this information.

Process connections

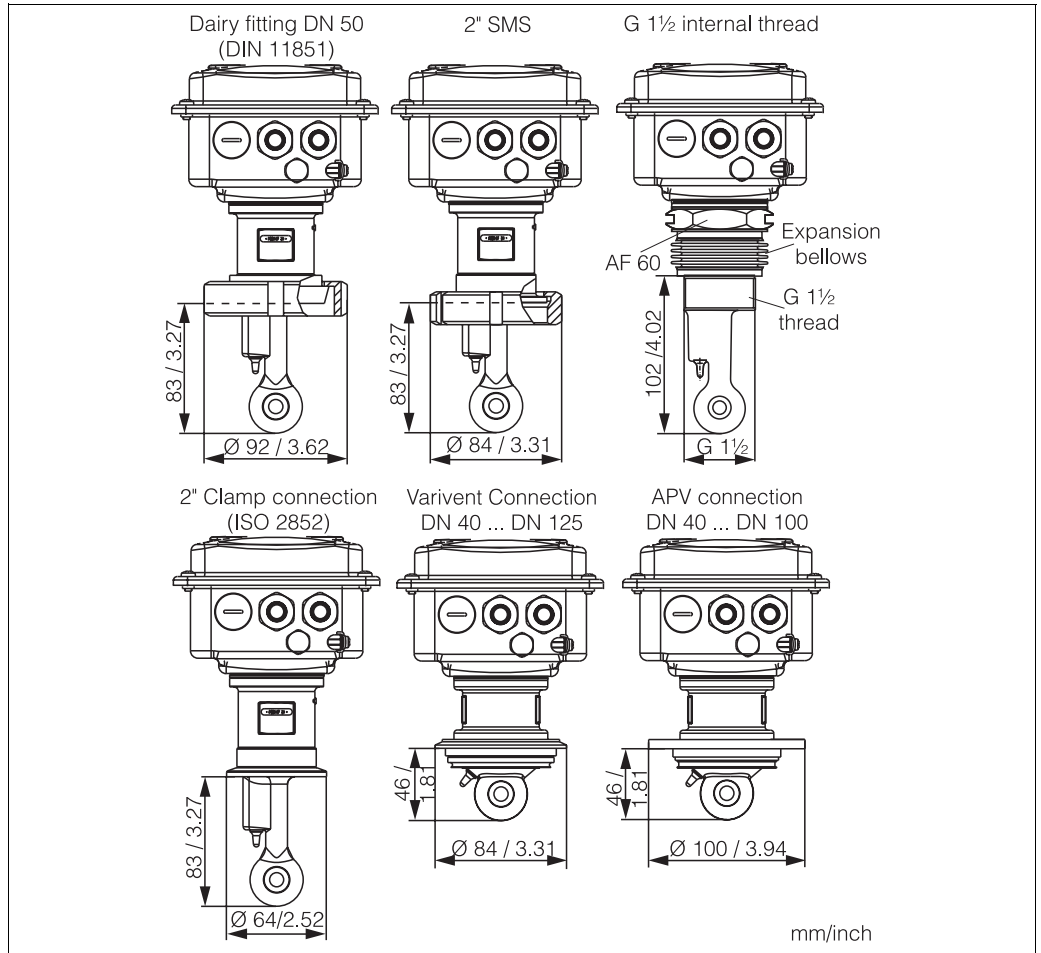

C07-CLD132xx-11-00-00-en-005.eps

Process connections of CLD132 compact version

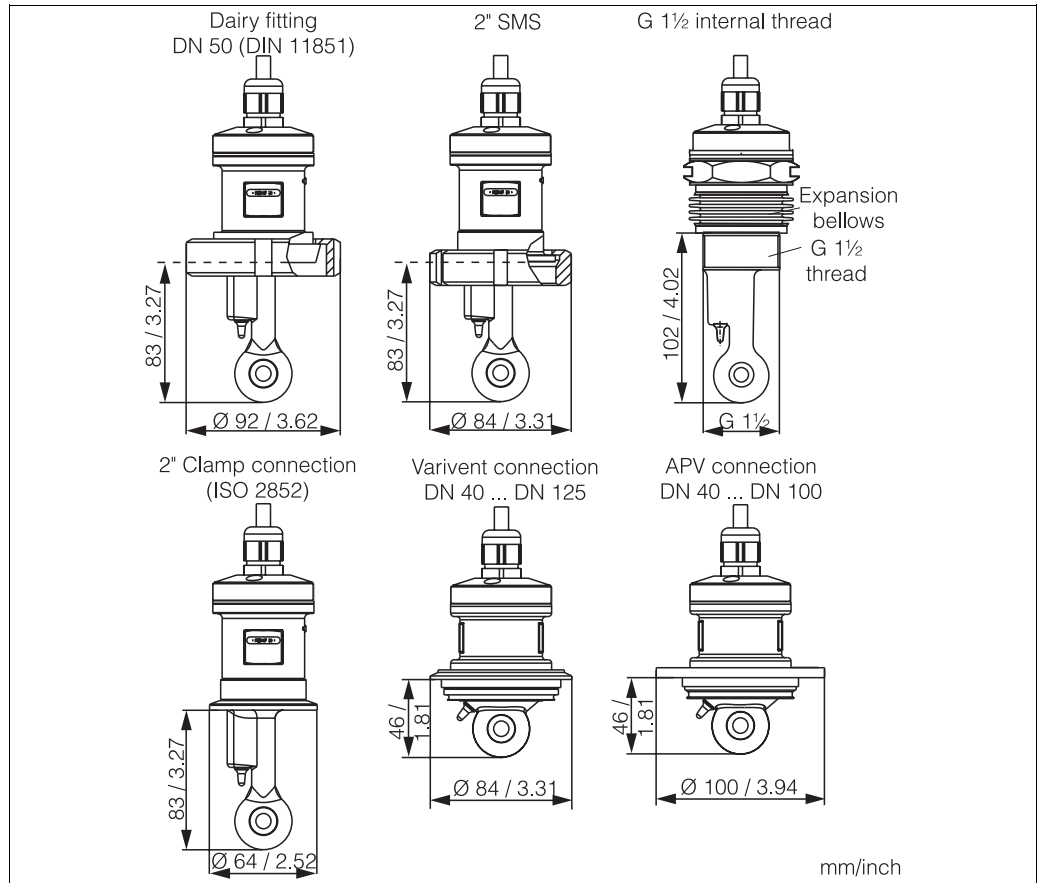

Process connections of CLS2 conductivity sensor

C07-CLD132ex-11-06-00-en-003.eps



Note!

■ Clamp connection

Sensors with clamp connections can be fixed using sheet metal brackets or solid brackets.

Sheet metal brackets have a lower dimensional stability, uneven bearing surfaces causing point loads and sometimes sharp edges that can damage the clamp.

We **strongly** recommend to always use solid brackets because of their higher dimensional stability. Solid brackets may be applied over the total pressure-temperature range (see diagram on page 11).

■ Threaded connection

Sensors with threaded connections are supplied with expansion bellows (compensator) to be able to align them in flow direction. The two O-rings (Viton) of the expansion bellows have no sealing function and are not in contact with medium. The process is usually sealed off by PTFE tape on the G 1½ thread.

Human interface

Display and operating elements

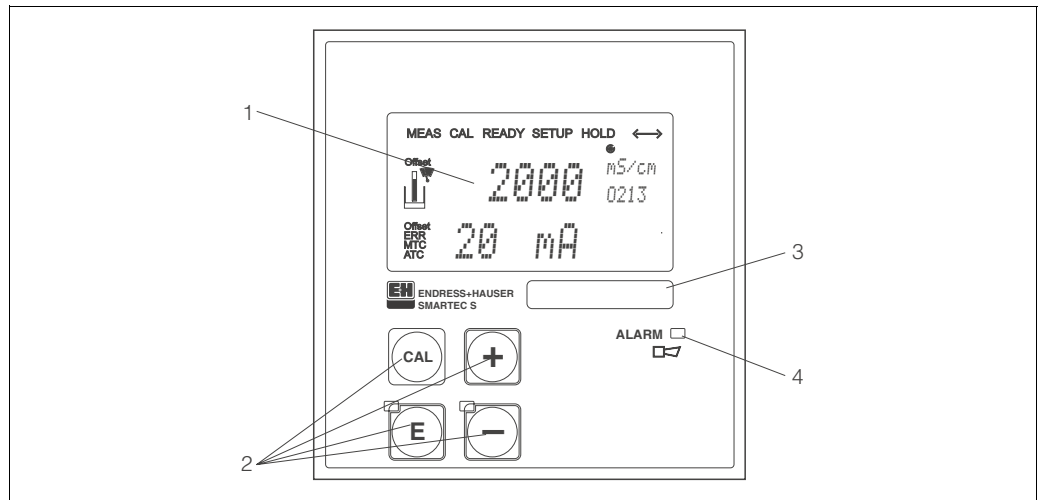

Display and keys of CLD132

C07-CLD132xx-19-06-00-xx-001.eps

- 1 LC display showing measured values and configuration data
- 2 Four operating keys for calibration and instrument configuration
- 3 Field for user labeling
- 4 LED indicator for alarm function

Operation

You have the following options of operating Smartec S CLD132:

- Local operation via operating keys
 - The four keys are located underneath the housing cover. For operation, open the housing cover by removing the four screws.
- Via HART® interface
 - HART hand-held terminal
 - PC with HART modem and the Communwin II software
- Via PROFIBUS PA/DP using a PC with a corresponding interface and the Communwin II software or via programmable logical controller (PLC)

Calibration and configuration functions

All calibration and configuration functions are arranged in a logical menu structure. The individual parameters can only be modified after entering the access code. The current position within the menu structure is displayed.

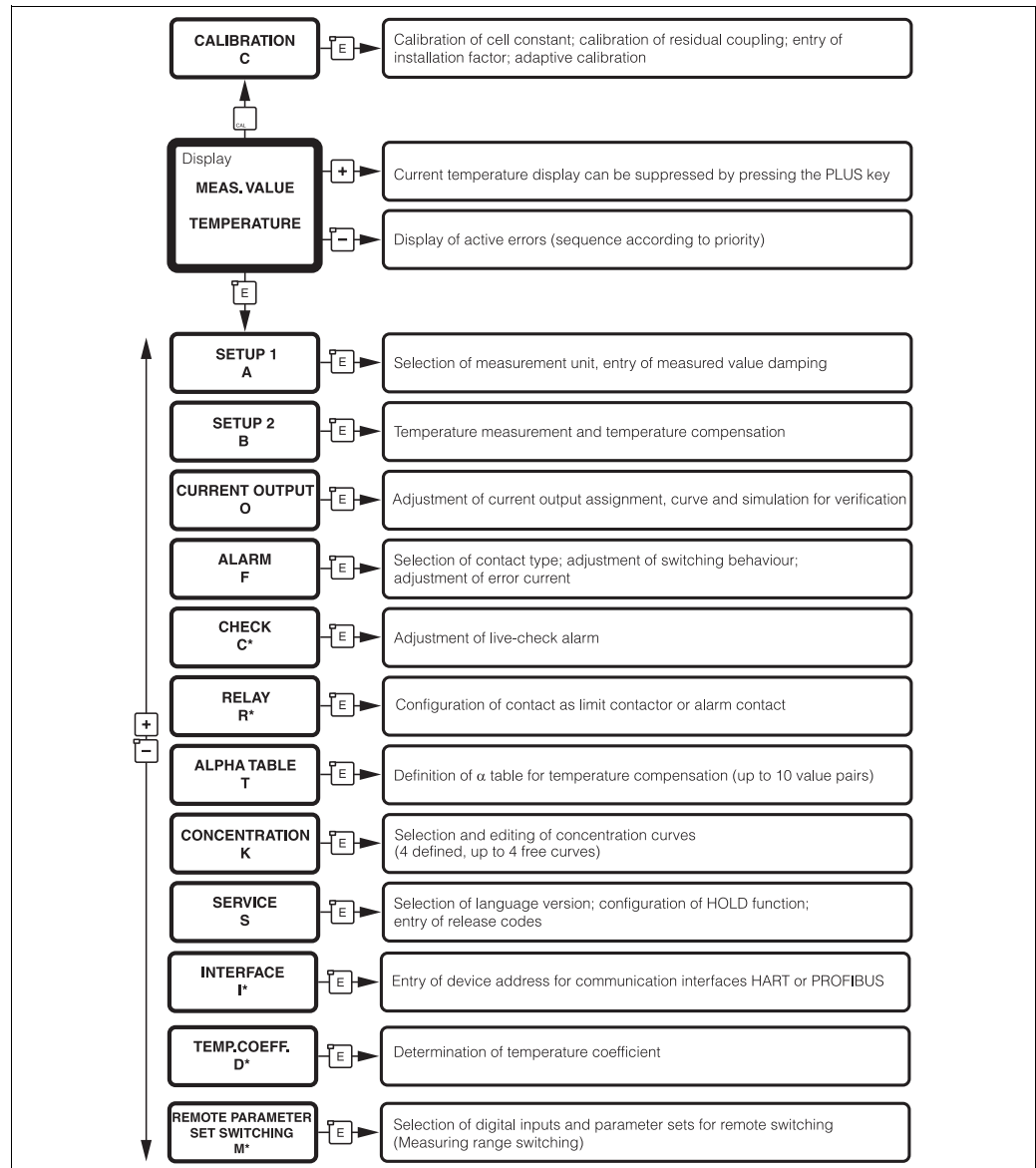

C07-CLD132xx-19-06-00-en-001.ags

Overview of the Smartec S CLD132 menu, showing all options that can be installed

* Menus not available in standard version

Ordering information

Product structure

Version	
P	Compact version
S	Separate transmitter, cable length 20 m / 65.62 ft
W	Separate transmitter, cable length 5 m / 16.41 ft
X	Separate transmitter, cable length 10 m / 32.81 ft
Process connection	
MV1	Dairy fitting DN 50 (acc. to DIN 11851)
CS1	Clamp connection 2" (acc. to ISO 2852)
GE1	Internal thread G 1 1/2
VA1	Varivent connection DN 40 ... 125
AP1	APV connection DN 40 ... 100
SMS	SMS connection 2"
Cable entry	
1	Cable gland Pg 13.5
3	Cable gland M 20 x 1.5
5	Conduit adapter NPT 1/2 "
Power supply	
0	230 V AC
1	115 V AC
5	100 V AC
8	24 V AC / DC
Current output / communication	
AA	Current output conductivity, without communication
AB	Current output conductivity and temperature, without communication
HA	HART, current output conductivity
HB	HART, current output conductivity and temperature
PE	PROFIBUS-PA, no current output
PF	PROFIBUS-PA, M 12 connector, no current output
PP	PROFIBUS-DP, no current output
Additional features	
1	Basic version with fast temperature measurement
2	Remote parameter set switching with fast temperature measurement
6	Basic version with encapsulated Pt 100 for high loads
7	Remote parameter set switching with encapsulated Pt 100 for high loads
CLD132-	complete order code

Scope of delivery

The scope of delivery of the compact version includes:

- Smartec S CLD132 compact measuring system with integrated sensor
- Terminal strip set
- Expansion bellows (-*GE1***** versions only)
- Operating Instructions BA 207C/07/en
- Versions with HART communication only:
Operating Instructions Field communication with HART, BA 212C/07/en
- Versions with PROFIBUS interface only:
– Operating Instructions Field communication with PROFIBUS, BA 213C/07/en
– M12 connector (-*****PF* versions only)

The scope of delivery of the separate version includes:

- Smartec S CLD132 transmitter
- CLS52 inductive sensor with fixed cable
- Terminal strip set
- Expansion bellows (-*GE1***** versions only)
- Operating Instructions BA 207C/07/en
- Versions with HART communication only:
Operating Instructions Field communication with HART, BA 212C/07/en
- Versions with PROFIBUS interface only:
– Operating Instructions Field communication with PROFIBUS, BA 213C/07/en
– M12 connector (-*****PF* versions only)

Basic version and function extensions

Functions of the basic version	Options and their functions
<ul style="list-style-type: none"> ■ Measurement ■ Calibration of cell constant ■ Calibration of residual coupling ■ Calibration of installation factor ■ Read instrument parameters ■ Linear current output ■ Current output simulation ■ Service functions ■ Temperature compensation selectable (e.g. 1 free coefficient table) ■ Concentration measurement selectable (4 defined curves, 1 free table) ■ Relay as alarm contact 	<ul style="list-style-type: none"> ■ Second current output for temperature (hardware option) ■ HART communication ■ PROFIBUS communication <p>Remote parameter set switching (software option):</p> <ul style="list-style-type: none"> ■ Remote switching of max. 4 parameter sets (measuring ranges) ■ Temperature coefficients can be determined ■ Temperature compensation selectable (e.g. 4 free coefficient tables) ■ Concentration measurement selectable (4 defined curves, 4 free tables) ■ Check of measuring system by PCS alarm (live check) ■ Relay can be configured as alarm or limit contact

Accessories

Cable extension

- Extension cable CLK5
for inductive conductivity sensors, for extension via the VBM junction box, sold by the metre;
order no.: 50085473

- Junction box VBM
for extension of measuring cable connection between sensor and instrument, material cast aluminium, ingress protection 65;
order no.: 50003987

 **Note!**

The desiccant bag must be checked and replaced at regular intervals which depend on ambient conditions in order to prevent inaccurate measurement due to moisture bridges in the measuring line.

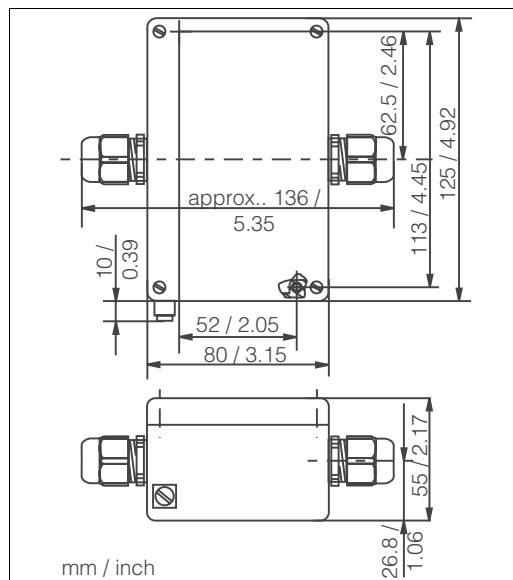

Dimensions of VBM junction box

C07-CLD132x-00-06-00-en-002.eps

- Desiccant bag with colour indicator for VBM junction box;
order no. 50000671

Pipe mounting kit

- Mounting kit for installation of Smartec S CLD132 on horizontal or vertical pipes and posts (max. Ø 60 mm / 2.36"), material stainless steel 1.4301; order no.: 50062121

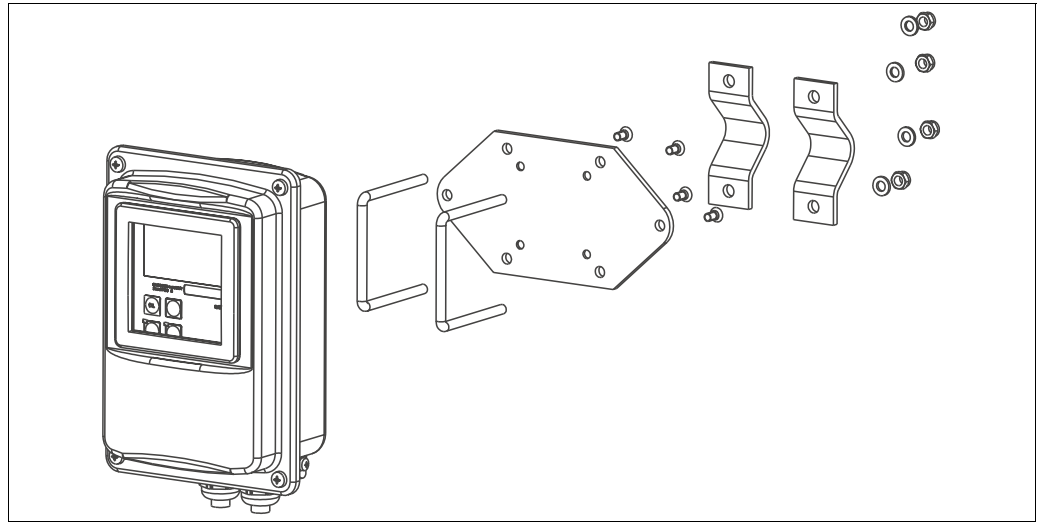

Mounting kit for installing CLD132 separate version on posts or pipes

C07-CLD132xx-00-06-06-001.eps

Software upgrade

- Software upgrade
Remote parameter set switching (measuring range switching, MRS) and determination of temperature coefficient;
order no.: 51501643
Serial number of instrument must be specified with order.

Optoscope

- Optoscope
Interface between transmitter and PC / laptop for service purposes.
The Windows software "Scopeware" required for the PC or laptop is supplied with the Optoscope. The Optoscope is supplied in a sturdy plastic case with all the accessories required.
Order no. 51500650

Calibration solutions

- Precision solutions, traceable to SRM (standard reference material) by NIST, for qualified calibration of conductivity measurement systems according to ISO 9000, with temperature table
- CLY11-B
149.6 µS/cm (reference temperature 25 °C / 77 °F), 500 ml / 0.13 US.gal.
Order no. 50081903
 - CLY11-C
1.406 mS/cm (reference temperature 25 °C / 77 °F), 500 ml / 0.13 US.gal.
Order no. 50081904
 - CLY11-D
12.64 mS/cm (reference temperature 25 °C / 77 °F), 500 ml / 0.13 US.gal.
Order no. 50081905
 - CLY11-E
107.0 mS/cm (reference temperature 25 °C / 77 °F), 500 ml / 0.13 US.gal.
Order no. 50081906

Related products

- Indumax H CLS52
Inductive conductivity sensor with fast response time and hygienic design; with integrated temperature sensor.
Order according to product structure, see Technical Information TI 167C/07/en.
One Indumax H CLS52 is included in the Smartec S CLD132 scope of delivery.

Documentation

- Smartec S CLD132, Operating Instructions BA207C/07/en
Order no.: 51501595
- Indumax H CLS52, Technical Information TI 167C/07/en
Order no.: 50086110
- PROFIBUS PA/DP, Field communication with Smartec S CLD132, Operating Instructions
BA 213C/07/en
Order no.: 51502194
- HART®, Field communication with Smartec S CLD132, Operating Instructions BA 212C/07/en
Order no.: 51502192

International Head Quarters

Endress+Hauser
GmbH+Co. KG
Instruments International
Colmarer Str. 6
79576 Weil am Rhein
Deutschland

Tel. +49 76 21 9 75 02
Fax +49 76 21 9 75 34 5
www.endress.com
info@ii.endress.com

TI207C/07/en/08.04
51501593
Printed in Germany / FM+SGML 6.0 / DT