



O2D101

Data Matrix Code Lesegerät
O2DIOS-G/D/RS232

Max. Lesefeldgröße
40 x 52 mm

Interne Beleuchtung:
Infrarot (880 nm)

Prozeßschnittstelle
RS232

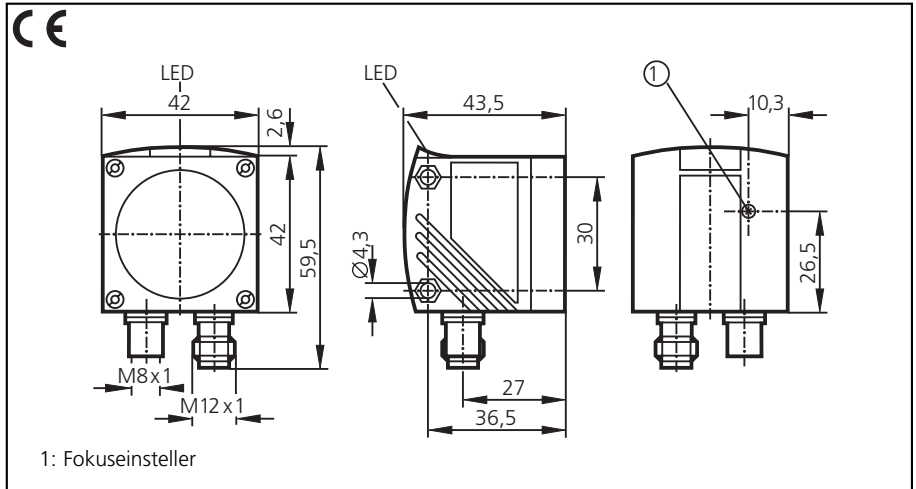

Sensortyp

Lesbare Code

Arbeitsabstand	[mm]
Lesefeldgröße	[mm]
Minimale Modulgröße	[mm]

Lage der Codierung

Neigungswinkel zur Bildebene

Lesungen

Bewegungsgeschwindigkeit

Funktionsanzeige

Betriebsbereitschaft [LED]

Verbindungsstatus [LED]

Code gelesen [LED]

Code nicht lesbar [LED]

Betriebsspannung [V]

Stromaufnahme [mA]

Umgebungstemperatur [°C]

Lagertemperatur [°C]

Schutzart, Schutzklasse

Werkstoff Gehäuse / Optik

Trigger

Parametriermöglichkeiten

Parametrierschnittstelle

Prozeßschnittstelle

Datenprotokolle

Baudrate der Prozeßschnittstelle [bits/s]

Anschluß

Anschlußschema

CMOS Bildsensor S/W, VGA-Auflösung 640x480

ECC200, 10 x 10 Module bis 44 x 44 Module; 8 x 18 Module bis 16 x 36 Module

	75	100	200
	14x18	20x26	40x52
	0,15	0,2	0,4

Orientierung parallel zum Lesefeld, in 90° Schritten positionierbar

0-45°

Max. 10 Lesungen/ s

Mit integrierter Beleuchtung max. 3 m/s

Mit externer Beleuchtung max. 5 m/s

grün

gelb

gelb

rot

24 DC (+/- 10%)

< 200

0 ... 50

-40 ... +80

IP 65, III

Zink Druckgruß, PC / PMMA

Extern, 24 V PNP gem. IEC 61131-1

Über PC / Notebook

USB über Adapterkabel E2D100

RS232

ASCII / R3964

9 600 - 38 400

Prozeßanschluß: RS232; M12 8-polig

Parametrieranschluß: RS485; M8 4-polig

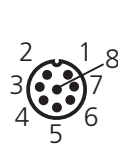

- 1 - U+
- 2 - Triggereingang
- 3 - OV
- 4 - Triggerausgang für externe Beleuchtung
- 5 - RxD
- 6 - TxD
- 7 - N.C.
- 8 - N.C.



- 1 - RxD-N / TxD-N
- 2 - RxD-P / TxD-P
- 3 - GND
- 4 - RTS



O2D101

Data matrix code reader
O2DIOS-G/D/RS232

Max. field of view size
40 x 52 mm

Integrated lighting:
infrared (880 nm)

Process interface
RS232

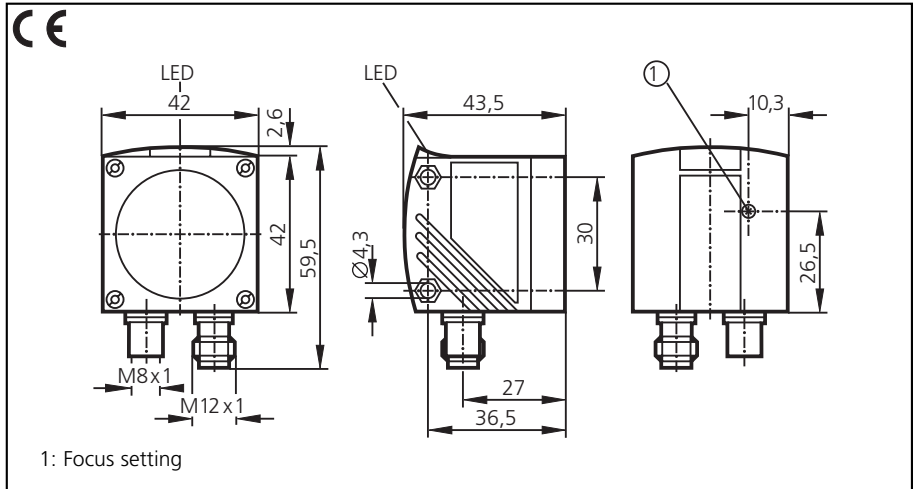

Sensor type

Readable codes

Operating distance	[mm]
Field of view size	[mm]
Minimum module size	[mm]

Coding position

Inclination angle to the image plane

Reading operations

Motion speed

Function display

Power [LED]

Connection status [LED]

Code read [LED]

Code not readable [LED]

Operating voltage [V]

Current consumption [mA]

Operating temperature [°C]

Storage temperature [°C]

Protection

Housing material / lens

Trigger

Parameter setting options

Parameter setting interface

Process interface

Data protocols

Baud rate of the
Process interface [bits/s]

Connection

Wiring

CMOS image sensor black/white, VGA resolution 640 x 480

ECC200, 10x10 modules up to 44x44 modules; 8x18 modules up to 16x36 modules

	75	100	200
	14x18	20x26	40x52
	0.15	0.2	0.4

orientation in parallel to the reading field, positionable in 90° steps

0-45°

max. 10 reading operations/s

with integrated lighting max. 3 m/s

with external lighting max. 5 m/s

green

yellow

yellow

red

24 DC (+/- 10%)

< 200

0 ... 50

-40 ... +80

IP 65, III

diecast zinc, PC / PMMA

external, 24 V PNP to IEC 61131-1

via PC / notebook

USB via adapter cable E2D100

RS232

ASCII / R3964

9 600 - 38 400

Process connection: RS232; M12 8-pole

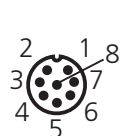

- 1 - U+
- 2 - trigger input
- 3 - OV
- 4 - trigger output for external lighting
- 5 - RxD
- 6 - TxD
- 7 - N.C.
- 8 - N.C.

parameter setting connection: RS485; M8 4-pole

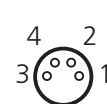

- 1 - RxD-N / TxD-N
- 2 - RxD-P / TxD-P
- 3 - GND
- 4 - RTS



O2D101

Lecteur de code Data Matrix
O2DIOS-G/D/RS232

Taille max. de la zone
de lecture 40 x 52 mm

Eclairage intégré:
infrarouge (880 nm)

Interface process
RS232

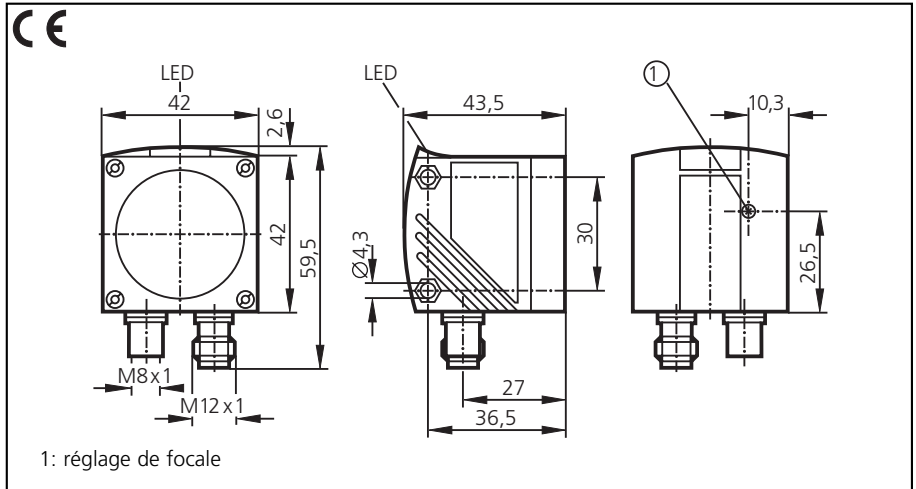

1: réglage de focale

Type de capteur

Codes lisibles

Portée de travail	[mm]
Taille de la zone de lecture	[mm]
Taille minimum modules	[mm]

Position du codage

Angle d'inclinaison par rapport au plan image

Lectures

Vitesse de mouvement

Indicateurs d'état

Disponibilité	[LED]
Etat de connexion avec PC	[LED]
Code lu	[LED]
Code non lisible	[LED]

Tension d'alimentation [V]

Consommation [mA]

Température ambiante [°C]

Température de stockage [°C]

Protection

Boîtier / lentille

Trigger

Options de paramétrage

Interface paramétrage

Interface process

Protocoles de données

Taux de transmission de l'interface de process [bits/s]

Raccordement

Schéma de branchement

Capteur d'image CMOS noir/blanc, résolution VGA 640 x 480

ECC200, 10x10 modules jusqu'à 44x44 modules; 8x18 modules jusqu'à 16x36 modules

	75	100	200
	14x18	20x26	40x52
	0,15	0,2	0,4

orientation en parallèle à la zone de lecture, positionnable en pas de 90°

0-45°

10 lectures/s max.

avec éclairage intégré 3 m/s max.
avec éclairage externe 5 m/s max.

verte
jaune
jaune
rouge

24 DC (+/- 10%)

< 200

0 ... 50

-40 ... +80

IP 65, III

zinc moulé sous pression, PC / PMMA

externe, 24 V PNP selon IEC 61131-1

par PC / PC portable

USB par câble adaptateur E2D100

RS232

ASCII / R3964

9 600 - 38 400

Raccord process: RS232; M12 8 pôles

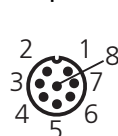

- 1 - U+
- 2 - entrée trigger
- 3 - OV
- 4 - sortie trigger pour l'éclairage externe
- 5 - RxD
- 6 - TxD
- 7 - N.C.
- 8 - N.C.

raccord paramétrage: RS485; M8 4 pôles

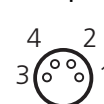

- 1 - RxD-N / TxD-N
- 2 - RxD-P / TxD-P
- 3 - GND
- 4 - RTS